

# Table of Contents

## Title 40

### LABOR AND EMPLOYMENT

#### Part I. Workers' Compensation Administration

##### Subpart 1. General Administration

Chapter 1.	General Provisions.....	1
§101.	Purpose.....	1
§103.	Definitions.....	1
§105.	Forms .....	1
§109.	Compliance Penalty .....	2
§111.	Restricted Work Notification.....	3
Chapter 3.	Electronic Billing.....	3
§301.	Purpose.....	3
§303.	Definitions.....	3
§305.	Formats for Electronic Medical Bill Processing.....	4
§306.	Electronic Medical Billing and Payment Companion Guide.....	5
§307.	Billing Code Sets .....	24
§309.	Electronic Medical Billing, Reimbursement, and Documentation .....	25
§311.	Employer, Insurance Carrier, Managed Care Organization, or Agents' Receipt of Medical Bills from Health Care Providers.....	26
§313.	Communication between Health Care Providers and Insurance Carriers.....	27
§315.	Medical Documentation Necessary for Billing Adjudication.....	28
§317.	Compliance and Penalty .....	28
§319.	Effective Date .....	28
Chapter 7.	Rehabilitation Services.....	28
§701.	Purpose.....	28
§703.	Statutory Requirements.....	28
§705.	Definitions.....	28
§707.	Responsibility to Provide Service .....	29
§709.	Use of Resources.....	29
§711.	Claims .....	29
§713.	Adjudication by Hearing Officer .....	29
§715.	Duration .....	29
§717.	Cost of Rehabilitation Services and Supplies .....	30
§719.	Location of Services .....	30
§721.	Penalty for Refusal.....	30
§723.	Payment of Temporary Disability.....	30
§725.	Approved List of Rehabilitation Providers .....	30
Chapter 9.	Safety Requirements.....	30
§901.	Statutory Requirements.....	30
§903.	Definitions.....	30
§905.	Availability of Safety Services .....	31
§907.	Classes and Components of Safety Plan.....	31
§909.	Submission of Safety Plan .....	33
§911.	Employee Notice.....	33
§913.	Lost Time Injury Reports.....	34

Table of Contents

Chapter 11.	Workers' Compensation Insurance Cost Containment .....	34
§1101.	Purpose.....	34
§1103.	Forms; Preparation and Adoption; Use.....	34
§1105.	Cost Containment Meeting .....	34
§1106.	Experience Modifier Rates.....	34
§1107.	Application for Attendance at Cost Containment Meeting.....	34
§1109.	Proof of Attendance; Certificate .....	35
§1111.	Failure to Attend; Fines .....	35
§1113.	Application for Participation in the Occupational Safety and Health Program.....	35
§1115.	Report to the Employer .....	35
§1117.	Standard for Satisfactory Implementation .....	35
§1119.	Inspections .....	36
§1121.	Certificate of Satisfactory Implementation .....	36
§1123.	Cost Credit Earned from Satisfactory Implementation.....	36
§1125.	Qualification for Cost Credit under R.S. 23:1179 .....	36
§1127.	Reapplication after Failure to Qualify .....	36
§1129.	Employer Eligibility for Safety and Health Program Assessment.....	37
§1131.	Discount Application Period.....	37
Chapter 15.	Drug Testing Programs in Job Related Accident Cases .....	37
§1501.	Introduction.....	37
§1503.	Scientific and Technical Requirements.....	37
§1505.	Specimen Collection Procedures .....	37
§1507.	Laboratory Analysis Procedures .....	39
§1509.	Reporting and Review of Results .....	41
Chapter 17.	Fiscal Responsibility Unit .....	41
§1701.	Financial Compliance .....	41
§1703.	Termination of Coverage by Insurance Carriers; Employer to Obtain New Coverage .....	41
§1705.	Definitions.....	41
§1707.	Conditions for Obtaining Certificate of Self-Insurance.....	42
§1709.	Acceptable Securities or Surety .....	42
§1711.	Filing of Reports—Penalties.....	43
§1713.	Contract of Excess Insurance.....	43
§1715.	Servicing for Self-Insurer; Qualifications for Service Companies .....	43
§1717.	Revocation or Termination of the Self-Insurer Privilege.....	44
§1719.	Enforcement by Office of Workers' Compensation of Order of Compliance; Order of Denial; or Order of Termination of Self-Insured Status.....	45
§1721.	Tenure of Authority .....	45
§1723.	Individual Self-Insurer—Application .....	45
§1725.	Security Requirements .....	46
§1727.	Forfeiture of Security .....	46
§1729.	Financial Classes, Security Amounts, and Waiver of Security .....	46
§1731.	Appeals .....	47
§1733.	Annual Reports .....	47
§1735.	Assessments .....	47
§1737.	Compliance Penalty .....	47
Chapter 19.	Fraud.....	47
§1901.	Forms .....	47
§1903.	Certification; Report .....	48
§1905.	Penalty; Hearing; Appeal.....	48
§1907.	Notice of Penalty; Filing.....	48

## Subpart 2. Medical Guidelines

Chapter 20.	Spine Medical Treatment Guidelines .....	49
Subchapter A.	Cervical Spine Injury .....	49
§2001.	Introduction .....	49
§2003.	General Guideline Principles .....	49
§2005.	Initial Diagnostic Procedures .....	51
§2007.	Follow-Up Diagnostic Imaging and Testing Procedures .....	53
§2009.	Therapeutic Procedures—Non-Operative .....	58
§2011.	Therapeutic Procedures—Operative .....	71
Subchapter B.	Low Back Pain .....	76
§2013.	Introduction .....	76
§2015.	General Guideline Principles .....	76
§2017.	Initial Diagnostic Procedures .....	78
§2019.	Follow-Up Diagnostic Imaging and Testing Procedures .....	79
§2021.	Therapeutic Procedures—Non-Operative .....	90
§2023.	Therapeutic Procedures—Operative .....	105
Chapter 21.	Pain Medical Treatment Guidelines .....	112
Subchapter A.	Chronic Pain Disorder Medical Treatment Guidelines .....	112
§2101.	Introduction .....	112
§2103.	General Guideline Principles .....	112
§2104.	Overview of Chronic Pain Management .....	114
§2105.	Introduction to Chronic Pain .....	115
§2107.	Definitions .....	117
§2109.	Initial Evaluation and Diagnostic Procedures .....	118
§2111.	Therapeutic Procedures—Non-Operative .....	125
§2113.	Therapeutic Procedures—Operative .....	173
§2115.	Maintenance Management .....	177
Subchapter B.	Complex Regional Pain Syndrome .....	180
§2117.	Introduction .....	180
§2119.	General Guideline Principles .....	180
§2121.	Introduction to Complex Regional Pain Syndrome .....	182
§2123.	Definitions .....	182
§2125.	Initial Evaluation .....	183
§2127.	Diagnostic Procedures .....	184
§2129.	Diagnosis of CRPS .....	187
§2131.	Therapeutic Procedures—Non-Operative .....	188
§2133.	Therapeutic Procedures—Operative .....	208
§2135.	Maintenance Management .....	209
Chapter 22.	Neurological and Neuromuscular Disorder Medical Treatment Guidelines .....	211
Subchapter A.	Carpal Tunnel Syndrome (CTS) Medical Treatment Guidelines .....	211
§2201.	Introduction .....	211
§2203.	General Guideline Principles .....	211
§2205.	Definitions .....	213
§2207.	Initial Diagnostic Procedures .....	213
§2209.	Follow-Up Diagnostic Testing Procedures .....	216
§2211.	Therapeutic Procedures—Non-Operative .....	219
§2213.	Therapeutic Procedures—Operative .....	225

Table of Contents

Subchapter B. Thoracic Outlet Syndrome .....	226
§2215. Introduction.....	226
§2217. General Guidelines Principles.....	226
§2219. Definition of Thoracic Outlet Syndrome .....	228
§2221. Initial Diagnostic Procedures .....	229
§2223. Follow-up Diagnostic Imaging and Testing Procedures.....	230
§2225. Therapeutic Procedures—Non-Operative.....	233
§2227. Therapeutic Procedures—Operative.....	242
Chapter 23. Upper and Lower Extremities Medical Treatment Guidelines.....	244
Subchapter A. Lower Extremities .....	244
§2301. Introduction.....	244
§2303. General Guidelines Principles.....	244
§2305. Initial Diagnostic Procedures .....	246
§2307. Follow-Up Diagnostic Imaging and Testing Procedures.....	249
§2309. Specific Lower Extremity Injury Diagnosis, Testing, and Treatment .....	251
§2311. Therapeutic Procedures—Non-Operative.....	286
§2313. Therapeutic Procedures—Operative.....	301
Subchapter B. Shoulder Injury Medical Treatment Guidelines .....	307
§2315. Introduction.....	308
§2317. General Guideline Principles .....	308
§2319. Initial diagnostic procedures .....	310
§2321. Follow-Up diagnostic imaging and testing procedures .....	313
§2323. Specific Diagnosis, Testing and Treatment .....	316
§2325. Therapeutic Procedures—Non-Operative.....	343
§2327. Therapeutic Procedures—Operative.....	356
§2328. LWC-WC 1009. Disputed Claim for Medical Treatment .....	358
Chapter 25. Hospital Reimbursement Schedule, Billing Instruction and Maintenance Procedures ....	359
§§2501-2503. Reserved.....	359
§2505. Hospital Inpatient Reimbursement .....	359
§2507. Outpatient Reimbursement .....	361
§2509. Psychiatric and Chemical Dependency Reimbursement .....	362
§2511. Rehabilitation Services Reimbursement.....	362
§2513. Skilled Nursing and Intermediate Facility Reimbursement.....	362
§2515. Hospice Services Reimbursement.....	362
§2517. Hospice Care Rate Schedule.....	363
§2519. Outlier Reimbursement and Appeals Procedures .....	363
§2521. Hospital Billing Instructions .....	366
§2523. Required Information for Billing Inpatient Services .....	366
§2525. Inpatient Services Not Billable on the UB-92 .....	368
§2527. Inpatient Revenue Codes Not Billable on the UB-92.....	368
§2529. Required Information for Billing Outpatient Services.....	368
§2531. Outpatient Services Not Billable on the UB-92.....	368
§2533. Outpatient Revenue Codes Not Billable on the UB-92 .....	369
§§2535-2537. Reserved.....	369
§2539. Annual Maintenance .....	369
§§2541-2553. Reserved.....	369
§2599. Appendix A—F.I.P.S. Area Codes .....	369
Chapter 27. Utilization Review Procedures .....	370
§2701. Statement of Policy .....	370
§2703. Introduction.....	370



Table of Contents

§2705.	Pre-Admission Certification .....	371
§2707.	Admission and Continued Stay Review .....	378
§2709.	Discharge Planning .....	381
§2711.	Second Surgical Opinion .....	381
§2713.	Ambulatory Surgery.....	382
§2715.	Medical Treatment Schedule Authorization and Dispute Resolution.....	383
§2717.	Medical Review Guidelines .....	390
§2718.	Utilization Review Forms .....	393
§2719.	Instructions for On-Site Audit of Hospital Charges by Workers' Compensation Carrier.....	395
Chapter 29.	Pharmacy Reimbursement Schedule, Billing Instruction and Maintenance Procedures ..	397
§§2901-2903.	Reserved. ....	397
§2905.	Covered Services .....	397
§2907.	Reimbursement .....	397
§2909.	Noncovered Services .....	397
§§2911-2913.	Reserved. ....	398
§2915.	Billing Instructions.....	398
§§2917-2927.	Reserved. ....	399
Chapter 31.	Vision Care Services, Reimbursement Schedule, Billing Instruction and Maintenance Procedures .....	399
§§3101-3113.	Reserved. ....	399
§3115.	Covered Services .....	399
§3117.	Benefit Detail and Limitations.....	399
§3119.	Maximum Allowable Reimbursement.....	400
§§3121-3139.	Reserved. ....	401
Chapter 33.	Hearing Aid Equipment and Services Reimbursement Schedule, Billing Instructions and Maintenance Procedures .....	401
§§3301-3323.	Reserved. ....	401
§3325.	Covered Services .....	401
§3327.	Physician Dispensing of Hearing Aids .....	403
§3329.	Reimbursement Schedule.....	403
§§3331-3341.	Reserved. ....	404
Chapter 35.	Nursing/Attendant Care and Home Health Services Reimbursement Schedule, Billing Instruction and Maintenance Procedures .....	404
§§3501-3505.	Reserved. ....	404
§3507.	Prior Authorization .....	404
§3509.	Training Requirements and Reimbursement Guidelines .....	404
§3511.	Maximum Allowable Reimbursement.....	405
§§3513-3535.	Reserved. ....	406
Chapter 37.	Home and Vehicle Modification Reimbursement Schedule, Billing Instructions and Maintenance Procedures.....	406
§§3701-3705.	Reserved. ....	406
§3707.	Prior Authorization .....	406
§3709.	Home Modifications .....	406
§3711.	Vehicle Modifications.....	407
§3713.	Reserved.....	407
§3715.	Schedule of Maximum Allowances .....	407
§§3717-3735.	Reserved. ....	407
Chapter 39.	Medical Transportation Reimbursement Schedule, Billing Instructions, and Maintenance Procedures .....	407
§§3901-3907.	Reserved. ....	407

Table of Contents

§3909.	Ambulance Services.....	407
§3911.	Schedule of Maximum Allowances .....	408
§§3913-3933.	Reserved. ....	408
Chapter 41.	Durable Medical Equipment and Supplies Reimbursement Schedule, Billing Instructions, and Maintenance Procedures .....	408
§§4101-4109.	Reserved. ....	408
§4111.	Durable Medical Equipment .....	408
§4113.	Equipment Rental/Purchase Guidelines.....	409
§4115.	Equipment Warranty and Repair Information .....	409
§4117.	Billing Instructions.....	409
§4119.	Maximum Allowance Schedules .....	411
§§4121.-4137.	Reserved. ....	416
Chapter 43.	Prosthetic and Orthopedic Equipment.....	416
§§4301-4309.	Reserved. ....	416
§4311.	Covered Services .....	416
§4313.	Nonlisted Items and Individual Consideration .....	416
§4315.	Noncovered Services .....	416
§4317.	Billing Instructions.....	416
§§4319-4337.	Reserved. ....	418
§4339.	Schedule of Maximum Allowances and Procedural Codes.....	418
Chapter 45.	Respiratory Services Reimbursement Schedule, Billing Instructions, and Maintenance Procedures .....	425
§§4501-4505.	Reserved. ....	425
§4507.	Prior Authorization .....	425
§4509.	Covered Services .....	425
§4511.	Noncovered Services .....	427
§§4513-4535.	Reserved. ....	427
§4537.	Maximum Reimbursement Allowance .....	427
Chapter 47.	Miscellaneous Claimant Expenses Reimbursement Schedule, Billing Instruction and Maintenance Procedures .....	428
§§4701-4731.	Reserved. ....	428
§4733.	Schedule of Maximum Allowances .....	428
§§4735-4743.	Reserved. ....	430
Chapter 49.	Vocational Rehabilitation Consultant Reimbursement Schedule, Billing Instruction and Maintenance Procedures .....	430
§§4901-4909.	Reserved. ....	430
§4911.	Covered Services .....	430
§4913.	Noncovered Services .....	431
§4915.	Schedule of Maximum Allowances .....	431
§4917.	Billing Code Instructions .....	431
§§4919-4939.	Reserved. ....	431
Chapter 51.	Medical Reimbursement Schedule .....	431
§5101.	Statement of Policy .....	431
§5103.	Introduction.....	432
§5105.	Verification of Coverage.....	432
§5107.	Other Payer Liabilities .....	432
§5109.	Prior Authorization .....	433
§5111.	Billing Instructions.....	433
§5113.	Coding System .....	433
§5115.	Surgery Guidelines.....	434

Table of Contents

§5117.	Anesthesia .....	436
§5119.	Deposition/Witness Fee Limitation .....	438
§5121.	Missed Appointments .....	438
§5123.	Copies of Records and Reports .....	438
§5125.	Special Instructions .....	439
§5127.	Physical Medicine .....	440
§5129.	Allergy and Clinical Immunology .....	444
§5131.	Biofeedback .....	444
§5133.	Injections .....	444
§5135.	Evaluation and Management .....	445
§5137.	Neurologic and Neuromuscular Services .....	445
§5139.	Psychiatry .....	446
§5141.	Soft Tissue Injury Care .....	446
§5143.	Thermography .....	447
§5145.	Carrier Responsibilities for Reimbursement Determinations .....	448
§5147.	Explanation of Medical Benefits (EOMB) .....	448
§5149.	Reconsideration of Disputed Reimbursements .....	448
§5151.	Out-of-State, On-the-Job Injuries or Work-Related Illness Treated in Louisiana .....	449
§5153.	In State Medical Treatment .....	449
§5155.	Maintenance of Schedule .....	449
§5157.	Maximum Reimbursement Allowances .....	450
Chapter 53.	Dental Care Services, Reimbursement Schedule and Billing Instructions .....	633
§5313.	Billing Instructions .....	633
§5315.	Coding System .....	636
§5317.	Covered Services .....	637
§5319.	Procedure Codes and Guidelines .....	637
§5321.	Maximum Allowable Reimbursement .....	637
§5329.	Special Instructions .....	637
§5341.	Annual Maintenance .....	638
§5399.	Schedule for Maximum Allowances for Dental Services .....	638

**Subpart 3. Hearing Rules**

Chapter 55.	General Provisions .....	647
Subchapter A.	Definitions .....	647
§5501.	Purpose; Definitions .....	647
Subchapter B.	Jurisdiction .....	647
§5503.	Jurisdiction Authority .....	647
§5505.	Jurisdiction over Subject Matter and Persons .....	647
Subchapter C.	Commencement .....	647
§5507.	Commencement of a Claim .....	647
§5509.	Delay for Answering .....	648
§5511.	Service .....	648
Subchapter D.	Venue .....	648
§5515.	Proper Venue .....	648
Subchapter E.	Recusal .....	648
§5525.	Procedure for Recusal of a Workers' Compensation Judge .....	648

Table of Contents

Subchapter F. Power and Authority.....	649
§5533. General.....	649
§5534. Submission and Investigation of Complaints alleging Judicial Misconduct or Disability.....	649
§5535. Contempt.....	649
§5537. Procedure .....	650
Subchapter G. Clerks.....	651
§5539. District Clerk; Pleadings Filed; Docket Books.....	651
Subchapter H. Bailiffs .....	651
§5541. Security .....	651
Subchapter I. Attorneys and Other Persons before the Court.....	651
§5543. Workers' Compensation Courtroom Decorum.....	651
§5545. Attorneys.....	651
§5547. Withdrawal of Counsel .....	651
Chapter 57. Actions.....	652
Subchapter A. General Provisions.....	652
§5701. Prescription; Filing Procedure .....	652
§5703. Prematurity.....	652
§5705. Abandonment.....	652
§5707. Class Actions .....	653
Subchapter B. Settlement .....	653
§5709. Joint Petition Settlements.....	653
Chapter 58. Pleadings.....	653
Subchapter A. General .....	653
§5801. Pleadings Allowed .....	653
Subchapter B. Supplemental/Amended Pleadings.....	653
§5805. Amendment of Claim and Answer .....	653
Subchapter C. Forms.....	653
§5809. Forms .....	653
§5811. Format of Documents .....	653
Subchapter D. Mediation.....	654
§5813. Mediation Conference.....	654
§5817. Conclusion of Mediation Conferences held by an Office of Workers' Compensation Mediator.....	654
§5819. Failure to Attend; Sanctions.....	655
Subchapter E. Petition.....	655
§5821. Required Elements .....	655
Subchapter F. Exceptions .....	655
§5823. Kinds of Exceptions; Time for Pleading.....	655
§5824. Rule to Show Cause; Time for Filing Memoranda.....	655
Subchapter G. Motions.....	655
§5831. Motion or Rule Day .....	655
§5833. Written Motion Required; Exception.....	655
§5835. Ex Parte and Contradictory Motions; Rule to Show Cause Favored.....	655
Chapter 59. Production of Evidence .....	656
Subchapter A. General .....	656
§5901. Discovery and Attendance of Witnesses.....	656
§5903. Objections to Evidence .....	656
§5905. Protective Orders .....	656

Table of Contents

Subchapter B. Subpoena .....	656
§5909. Issuance; Service.....	656
§5911. Exceptions.....	656
§5913. Subpoena of Confidential Records .....	656
Subchapter C. Discovery.....	656
§5915. Scope of Discovery .....	656
Subchapter D. Depositions.....	657
§5921. General; When Taken .....	657
§5925. Depositions in Advance of Hearing; Perpetuation of Testimony .....	657
§5927. Expert Witness Fee .....	657
Subchapter E. Interrogatories.....	657
§5931. General.....	657
Subchapter F. Production of Documents .....	657
§5933. Production of Documents; General; Medical Evidence.....	657
Subchapter G. Admissions .....	657
§5941. Requests for Admission .....	657
Subchapter H. Medical Examinations .....	657
§5943. Independent Medical Examinations; Report; Deposition of Examiner; Objections.....	657
§5953. Right of an Employee to Written Report of Medical Examination .....	657
Subchapter I. Motion to Compel.....	658
§5955. Motion for Order Compelling Discovery.....	658
Subchapter J. Sanctions.....	658
§5961. Refusal to Obey Subpoena.....	658
§5963. Failure to Comply with Order Compelling Discovery .....	658
Chapter 60. Pretrial Procedure .....	658
§6001. Scheduling Conferences.....	658
§6005. Pretrial Conference .....	658
§6007. Pretrial Order .....	659
Chapter 61. Hearings.....	659
Subchapter A. Expedited Hearings .....	659
§6101. Examination of an Injured Employee .....	659
Subchapter B. Continuance and Stays .....	659
§6103. General .....	659
§6104. Stays.....	659
Chapter 62. Trial .....	660
Subchapter A. Trial Procedure .....	660
§6203. Trial on the Merits .....	660
§6205. Cumulative Medical Testimony.....	660
§6209. Testimony of Medical Personnel .....	660
Subchapter B. Dismissal .....	660
§6211. Dismissal.....	660
Subchapter C. Assessment of Costs .....	660
§6215. Assessment of Costs .....	660
Chapter 63. Judgments.....	660
Subchapter A. General .....	660
§6301. Submission of Evidence Submission for Judgement/Decision; Post Hearing Briefs .....	660
§6303. Completion of Trial; Pronouncement of Judgment; Time for Judgments or Orders; Written Reasons .....	660
Subchapter B. Default .....	661
§6305. Default; General Provisions; Scope of Judgment .....	661

Table of Contents

Subchapter C. Modification .....	661
§6311. General .....	661
§6313. Amendment of Judgment .....	661
§6315. Request for Modification .....	661
§6317. Exception .....	661
Chapter 64. Appellate Procedure .....	661
Subchapter A. General .....	661
§6401. General .....	661
§6405. Payment of Appellate Costs .....	661
Chapter 65. Special Disputes .....	661
Subchapter A. Attorney Fees.....	661
§6501. Disputed Attorney Fees.....	661
§6503. Attorney Fees; Application, Review and Approval .....	662
§6505. Reserved.....	662
Subchapter B. Social Security Offset.....	662
§6507. Offset.....	662
Subchapter C. Financial and Compliance Hearings.....	662
§6509. Financial and Compliance Hearings .....	662
Chapter 66. Miscellaneous .....	662
Subchapter A. General .....	662
§6601. Other Applicable Rules .....	662
§6603. Local Rules Prohibited.....	662
§6605. Fees .....	663
§6607. Posting of Docket.....	663
Subchapter B. Costs .....	663
§6609. General .....	663
§6611. Medical Costs.....	664
Subchapter C. Waiver of Costs for Indigent Party.....	664
§6613. General .....	664
Subchapter D. Severability of Sections .....	664
§6627. General .....	664
Subchapter E. Forms .....	665
§6629. Annual Report of Workers' Compensation Costs; Form LDOL-WC-1000.....	665
§6631. Notice of Payment, Modification, Suspension, Termination or Controversion of Compensation or Medical Benefits .....	667
§6633. Stop Payment Form; Form LDOL-WC-1003 .....	670
§6635. Request for Social Security Benefits Information; Form LDOL-WC-1004.....	671
§6637. Motion for Recognition of Right to Social Security Offset; Form LDOL-WC-1005A .....	672
§6639. Order Recognizing Right to Social Security Offset; Form LDOL-WC-1005B .....	672
§6641. Subpoena for Deposition and Subpoena Deuces Tecum; Form LDOL-WC-1006A.....	672
§6643. Subpoena Deuces Tecum for Inspection; Form LDOL-WC-1006B .....	673
§6645. Subpoena and Subpoena Deuces Tecum; Form LDOL-WC-1006C .....	673
§6647. Employer's Report of Injury/Illness; Form LWC-WC-IA-1 .....	674
§6649. Disputed Claim for Compensation; Form LDOL-WC-1008.....	675
§6651. Request for Compromise and Lump Sum Settlement; Form LDOL-WC-1011 .....	676
§6653. Request for Independent Medical Examination; Form LDOL-WC-1015 .....	678
§6655. Employer's Report of Occupational Injury and Illness Quarterly Summary; Form LDOL-WC-1017A .....	679
§6657. Employee's Monthly Report of Earnings; Form LDOL-WC-1020 .....	679
§6659. Employee and Employer Certificate of Compliance; Form LDOL-WC-1025.....	680

Table of Contents

§6661. Employee's Quarterly Report of Earnings; Form LDOL-WC-1026..... 681  
§6662. Attorney Fee Notice of Lien; Form LDOL-WC-1027..... 681  
§6663. Scheduling Order; Form LDOL-WC-1028..... 682  
§6664. Choice of Physician; Form LDOL-WC-1121 ..... 682  
§6665. Workers' Compensation Records Request Form; LWC-WC-1150..... 683  
§6667. Employee Authorization for OWCA to Release..... 684

**Part III. Workers' Compensation Second Injury Board**

Chapter 1. General Provisions..... 685  
§101. Approval of Settlements; Requirements; Computation of Time ..... 685  
§103. Domicile of Board, Time of Meeting, Special Meetings..... 687  
§105. Definitions..... 687  
§107. Presentation of Claim for Reimbursement from Second Injury Fund, Timely Filing  
Thereof..... 687  
§109. Disposition of Claim..... 687  
§111. Commencement of Hearings..... 687  
§115. Notice..... 688  
§117. Answer or Appearance..... 688  
§119. Leave to Intervene Necessary ..... 688  
§121. Default in Answering or Appearing..... 688  
§123. Hearing Procedure ..... 688  
§125. Finality of Board's Decision..... 689  
§127. Appeal..... 689  
§129. Stenographic Record of Hearing..... 689  
§131. Docket..... 689  
Chapter 3. Assessments..... 689  
§301. Assessment; Calculation of Rate ..... 689  
§303. Assessment; Due Date; Notice..... 689  
§305. Assessments—Failure to Pay; Penalties; Collection ..... 689  
§307. Ineligibility for Reimbursement..... 690  
Chapter 5. Forms..... 690  
§501. Request for Reimbursement; Form B ..... 690  
§502. Louisiana Workers' Compensation Second Injury Board Post-Hire/Conditional  
Job Offer Knowledge Questionnaire; Form D..... 691

**Part IV. Employment Security**

**Subpart 1. Board of Review**

Chapter 1. General Provisions..... 697  
§101. Office and Officers of the Board of Review ..... 697  
§103. Time and Place of Meeting of the Board..... 697  
§105. Quorum ..... 697  
§107. Computation of Time—Saturdays, Sundays and Holidays ..... 697  
§109. Appeals to the Appeals Tribunal and Board of Review..... 697  
§111. Notice of Hearing..... 698  
§113. Postponements, Continuances, Reopenings, and Rehearings..... 698  
§115. Conduct of Hearing before Administrative Law Judge ..... 699  
§117. Authority to Separate Witnesses (Placing Witnesses under the Rule)..... 699  
§119. Additional Testimony ..... 699  
§121. Stipulation of Facts ..... 699

Table of Contents

§123.	Decision of Administrative Law Judge.....	699
§125.	Appeals to Board.....	700
§127.	Notification of Appeal .....	700
§129.	Decision of the Board .....	700
§131.	Issuance of Subpoenas .....	700
§133.	Representation before the Administrative Law Judge and Board.....	700
§135.	Disqualification of Representative.....	700
§137.	Availability of Rules .....	700
Chapter 3.	Employment Security Law .....	700
§301.	Authority .....	700
§303.	Training of Administrative Law Judges.....	701
§305.	Posting of Cards, Statements and Material Relating to the Louisiana Employment Security Law, R.S. 23:1471-1713 as Amended .....	701
§307.	Contributions, Interest, Mailing Date of Contributions and Contribution Reports .....	701
§311.	Instructions on Reports .....	701
§313.	Records .....	701
§315.	Reserved.....	702
§317.	Employer Registration When Required .....	702
§319.	Identification of Workers .....	702
§321.	Reserved.....	702
§323.	Separation Notices .....	702
§324.	Reply to Notice of Eligibility.....	703
§325.	Definitions of Week .....	703
§327.	Types of Unemployment.....	703
§329.	Registration for Work and Claims for Benefits for Total and Part-Total Unemployment ...	704
§331.	Registration for Work and Claims for Benefits for Partial Unemployment .....	704
§335.	Witness Fees in Appeal Hearing.....	705
§337.	Payment of Benefits and Change of Address .....	705
§339.	Interstate Claims .....	705
§341.	Regulations for Interstate Charging .....	705
§343.	Employer Elections to Cover Multi-State Workers .....	706
§345.	Recognition of Heirs of Deceased Benefit Claimants .....	707
§347.	Transfer of Experience-Rating Record to Successor Where Segregable and Identifiable Part or Portion of the Business Is Acquired.....	707
§349.	Contribution and Wage Reports Covering Seamen and Seamen's Wages Paid under Shipping Articles .....	708
§351.	Benefit Determination Notice .....	708
§353.	Disclosure of Information Pursuant to R.S. 23:905.....	709
§355.	Services to Claimants.....	709
§357.	Terms and Conditions Not Applicable to Claims for Payment of Extended Compensation	709
§359.	Approved Training Definition .....	709
§361.	Types of Employment.....	710
§363.	Proof of Unemployment by a Principal Officer or Controlling Stockholder, or Relative thereof, of a Corporation, Partnership or Proprietorship .....	710
§364.	Reciprocal Offset .....	710
§367.	Assignment of Rates for Corporate Groups.....	710
§368.	Disqualification for Benefits Pursuant to R.S. 23:1601(8)(a).....	711
§369.	Waiver of Overpayment Recovery .....	711
§371.	Overpayment Recovery.....	712
§373.	Medical Services Performed by Physician or Professional Corporation .....	712



Table of Contents

§375.	Determining Whether Workers are Employees or Independent Contractors .....	712
§377.	Electronic Filing and Payment Requirements.....	713
§379.	Criminal History Background Check for Access to Federal Tax Information .....	714
§381.	Employer Requirement to Provide Notification of the Availability of Unemployment Insurance Benefits to Each Individual Employee at the Time of Separation .....	715
Chapter 5.	Lost Wage Benefits for Domestic Violence Victims .....	715
§501.	Terminology Pertaining to Lost Wages for Domestic Violence Victims .....	715
§503.	Administration of Funds .....	715
§505.	Manner of Distribution .....	716
§507.	Maximum Benefit Amount .....	716
§509.	Filing Period.....	716
§511.	Deductions .....	716
§513.	Availability of Claimant .....	716

**Part VII. Conditions under Which Minor Labor May Be Used**

Chapter 1.	Minimum Age Standards for Nonagricultural Employment .....	717
§101.	Oppressive Child Labor .....	717
§103.	Employment Standards for Minors under 16 Years of Age.....	717
Chapter 2.	Occupations Permitted for 14 and 15 Year-Old Minors .....	718
§201.	Types of Employment.....	718
§203.	Occupations Permitted for Minors under 16 Years of Age in Theatrical Performances, Exhibitions, Commercial Motion Pictures, Films, Video Productions, or Modeling .....	718
Chapter 3.	Occupations Not Permitted.....	719
§301.	Occupations Not Permitted for 14 and 15 Year-Old Minors .....	719
§303.	Employment of Minors 16 and 17 Years of Age .....	719
Chapter 5.	Hazardous Occupations .....	719
§501.	Preface.....	719
§503.	Manufacturing or Storage Operations Involving Explosives.....	720
§505.	Occupations Involving Motor Vehicles .....	720
§507.	Occupations in Connection with Mining .....	720
§509.	Logging and Sawmill Operations .....	721
§511.	Power Driven Woodworking Machine Occupations .....	721
§513.	Occupations Which Involve Operations of Power-Driven Circular Saws, Band Saws, and Guillotine Shears .....	721
§515.	Power-Driven Metal-Forming, Rolling, Punching, and Shearing Machine Occupations ....	722
§517.	Power-Driven Paper-Product Machine Occupations .....	722
§519.	Power Driven Bakery Machine Occupations.....	723
§521.	Power Driven Hoisting Apparatus Occupations .....	723
§523.	Wrecking, Demolition, and Shipbreaking Occupations.....	724
§525.	Brick, Tile and Kindred Products Manufacturing Occupations.....	724
§527.	Roofing Occupations .....	724
§529.	Excavation Occupations.....	724
§531.	Slaughtering, Meat-Packing or Processing, or Rendering Occupations .....	724
§533.	Occupations Involving Exposure to Radioactive Substances and Ionizing Radiation .....	725
§535.	Occupations Involving Use of or Contact with Lead or any Other Toxic Substance.....	725
§537.	Welding Occupations.....	725
§539.	Registered Apprentices .....	725
§541.	Registered Student Learners .....	726

## Part IX. Apprenticeship

Chapter 1.	Apprenticeship Laws .....	727
§101.	Definitions .....	727
§103.	Purpose of the Louisiana Apprenticeship System .....	727
§105.	State Apprenticeship Council .....	727
§107.	Duties and Responsibilities of the State Apprenticeship Council .....	728
§109.	Powers and Duties of the Director of Apprenticeship .....	728
Chapter 3.	Apprenticeship Division Standards and Procedure .....	729
§301.	Standards of Apprenticeship .....	729
§303.	Apprenticeship Agreements .....	731
§305.	Procedure for Approval of Apprenticeship Agreements .....	732
§307.	Procedure for the Cancellation or Termination of Apprenticeship Agreements and Issuance of Interim Credentials and Certificates of Completion .....	732
§309.	Settlement of Controversies or Complaints, Deregistration Proceedings .....	732
§311.	Civil Penalties .....	734
§313.	Cooperation with Other Organizations .....	734
§315.	Limitations .....	735
§317.	Criteria for Apprenticeable Occupations .....	735
Chapter 5.	Louisiana State Plan for Equal Opportunity in Apprenticeship .....	735
§501.	Scope and Purpose .....	735
§503.	Definitions .....	735
§505.	Authority .....	736
§507.	Equal Opportunity Standards .....	736
§509.	Affirmative Action Plans .....	737
§511.	Selection of Apprentices .....	739
§513.	Existing List of Eligibles and Public Notices .....	741
§515.	Records .....	741
§517.	Compliance Reviews .....	741
§519.	Noncompliance with Federal and State Equal Opportunity Requirements .....	742
§521.	Complaint Procedure .....	742
§523.	Adjustments in Schedule for Compliance Review or Complaint Processing .....	743
§525.	Sanctions .....	743
§527.	Reinstatement of Program Registration .....	743
§529.	Intimidatory or Retaliatory Acts .....	743
§531.	Nondiscrimination .....	744
§533.	Exemptions .....	744
§535.	Severability Clause .....	744
Chapter 7.	Apprenticeship Tax Credit .....	744
§701.	Authority .....	744
§703.	Definitions .....	744
§705.	Purpose .....	745
§707.	Eligibility .....	745
§709.	Method of Computation .....	746
§711.	Method of Reporting .....	746
§713.	Limitations .....	746

### **Part XIII. Job Training Partnership Act**

Chapter 1.	General Provisions.....	747
§101.	Definitions.....	747
§105.	Accounting Procedures .....	749
§107.	Reporting of Expenditures .....	749
§109.	Requests for Cash .....	749
§111.	Purchasing Procedures .....	749
§112.	Advertising.....	749
§113.	Travel and Transportation Regulations.....	749
§114.	Printing and Reproduction Costs .....	750
§115.	Personnel, Salary Regulations and Fringe Benefits .....	750
§116.	Advisory Councils .....	750
§117.	Auditing Requirements .....	750
§119.	Nonallowable Costs .....	751
§120.	Fees or Profits .....	751
§121.	Carry-Over Balances.....	751
§122.	Depreciation and/or Use Allowance .....	753
§124.	Building Space and Related Facilities .....	753
§125.	Financial and Programmatic Monitoring and Record Retention .....	753
§126.	Insurance Costs .....	754
§127.	Inventory Control.....	754
§128.	Taxes .....	754
§129.	Contractual Agreement .....	754
§130.	Preagreement Costs.....	754
§131.	Bonding.....	754
§133.	Professional, Personal, and Consultant Services .....	755
§141.	Redesignation of Service Delivery Area Grant Recipient .....	755
§143.	Maintenance of Document.....	755
§145.	Modification/Amendment of Service Delivery Area Job Training Plan .....	755
§147.	Participant Rights and Benefits.....	755
§148.	Payments to OJT Employers, Training Institutions, and Other Vendors .....	755
§149.	Grievance Procedure .....	755
§151.	Nondiscrimination Procedure .....	756
§153.	Participant Supportive Services .....	756
§155.	Conditional Approval of Job Training Plan.....	756
§159.	Administrative Cost Pooling.....	756
§161.	Statewide Management Information System .....	756
§163.	Prevention of Fraud and Program Abuse.....	756
§165.	Governor's Responsibility .....	758
§167.	CETA Property .....	758
§169.	Occupational Demand.....	758
§171.	Labor Organizations.....	759
§173.	Deadlines.....	759

### **Part XV. Private Employment Services**

Chapter 1.	General Provisions.....	761
§101.	Definitions.....	761
§103.	Operational Mandates .....	761
§107.	Prohibited Conduct .....	761

## Table of Contents

§109.	Application for License.....	762
§111.	Reporting Requirements .....	763
§113.	Examinations.....	763
§115.	Fees for Placement.....	764
§117.	Investigations .....	764
§119.	Revocation .....	764
§123.	Private Employment Services Contract .....	764
§125.	Private Employee Service Contract for Sitters/Nurses .....	765
§127.	Private Employment Services Contract for Applicant Escrow Account .....	765
§129.	Severability Clause .....	766

### **Part XVI. Customized Training**

Chapter 1.	Workforce Development Training Fund .....	767
§101.	Definitions.....	767
§103.	Eligibility .....	767
§105.	Criteria .....	768
§107.	Application Procedure .....	768
§109.	Submission and Review Procedure.....	768
§111.	General Award Provisions .....	769
§113.	Small Business Employee Training Program .....	770

### **Part XVII. Community Services Block Grant**

#### **Subpart 1. CSBG Policy Manual**

Chapter 1.	Allocation of Funds .....	773
§101.	Method of Allocation.....	773
§103.	Identification of Eligible Entities.....	773
§105.	Notification of Availability of Funds.....	773
Chapter 3.	Subgrant Proposal for Eligible Entities .....	773
§301.	Date of Submission .....	773
§303.	Content of Subgrant Proposal .....	773
§305.	Attachments to Subgrant Proposal.....	774
§307.	Review and Approval of Subgrant Proposal.....	774
Chapter 5.	Application for Discretionary Funds .....	774
§501.	Who May Apply .....	774
§503.	Requirement of Agency .....	774
§505.	Proposal.....	774
Chapter 7.	Governing Boards.....	775
§701.	Requirements .....	775
Chapter 9.	Fiscal Policy .....	776
§903.	Fiscal System for Subgrantees .....	776
§905.	Separate Bank Account.....	776
§907.	Payment of Funds .....	776
§909.	Expenditure Reports.....	776
§911.	Closeout of Subgrant.....	776
§913.	Carryover Funds.....	777
§915.	Audits .....	777

## Table of Contents

Chapter 11.	Costs .....	777
§1101.	Allowable Costs .....	777
§1103.	Nonallowable Costs .....	777
§1105.	Costs Requiring Prior Approval.....	778
Chapter 13.	Subcontractors and/or Third Party Agreements .....	778
§1301.	Content of and Monitoring Subcontractors and/or Third Party Agreements.....	778
Chapter 15.	Procurement Policies .....	778
§1501.	Public and Private Agencies .....	778
§1505.	State Contract Bid List.....	779
§1509.	Equipment Purchased with CSBG Funds .....	779
§1513.	Loaned Equipment .....	779
§1515.	Sole Source Procurement .....	779
§1517.	Leases of Space.....	779
§1521.	Equipment Lease.....	779
Chapter 17.	Personnel .....	780
§1701.	Establishment of Personnel Policy.....	780
Chapter 19.	Travel Policy .....	780
§1901.	Establishment of Policy .....	780
Chapter 21.	Reporting .....	780
§2101.	Activity Reports .....	780
Chapter 23.	Availability and Retention of Records .....	780
§2301.	Record Availability .....	780
Chapter 25.	Civil Rights Policy .....	780
§2501.	Affirmative Action Plan.....	780
§2503.	Implementation .....	780
Chapter 27.	Clarification of Rules .....	781
§2701.	Method for Clarification .....	781
Chapter 29.	Appeal of Termination or Reduction of Funding .....	781
§2901.	Termination and Reduction of Funding; Appeal .....	781
§2903.	Selection of Hearing Officer and Responsibilities.....	781
§2905.	Hearing Notice .....	782
§2907.	Decision; Appeal.....	783

### **Part XIX. Louisiana Workforce Commission**

Chapter 1.	Community and Technical Colleges Investment Fund .....	785
§101.	Purpose.....	785
§103.	Definitions.....	785
§105.	Eligibility .....	785
§107.	Criteria .....	785
§109.	Application Procedure .....	786
§111.	Submission and Review Procedure.....	786
§113.	General Award Provision.....	787
Chapter 3.	General Rules .....	787
§301.	Interested Party Petitions .....	787

Table of Contents

**Part XXI. High Unemployment Areas**

Chapter 1. Certification of High Unemployment Areas ..... 789  
    §101. Application Fee ..... 789

**Part XXVII. Civil Service Commission**

Chapter 1. Public Officials and Employees ..... 791  
    §101. Election of Employee Member of the State Civil Service Commission..... 791

**Title 40**  
**LABOR AND EMPLOYMENT**  
**Part I. Workers' Compensation Administration**  
**Subpart 1. General Administration**

**Chapter 1. General Provisions**

**§101. Purpose**

A. The purpose of the rules and regulations is to define the responsibilities and rights of the employee, employer and the carrier in the administration of workers' compensation in Louisiana.

B. The rules are intended to expedite the receipt of benefits by the injured worker; to insure that the proper rate of compensation is paid; to aid in the rehabilitation of the injured worker; to provide for collection of statistical data; to provide for review of safety plans; and, where necessary, to facilitate the resolution of disputes regarding benefits.

AUTHORITY NOTE: Promulgated in accordance with R.S. 23:1021.

HISTORICAL NOTE: Promulgated by the Department of Labor, Office of Workers' Compensation Administration, LR 11:775 (August 1985), amended by the Department of Employment and Training, LR 17:357 (April 1991).

**§103. Definitions**

A. For the purposes of these rules, the following definitions apply.

*Act*—the Louisiana Workers' Compensation Law, Chapter 10, R.S. 23.

*Carrier*—unless otherwise indicated, insurance companies, self-insured employers and group self-insured employers.

*Certificate*—the notice the office is required to give after its recommendation is rejected.

*Clerk*—the clerks of the district courts in Louisiana.

*Commissioner*—the commissioner of insurance for the state of Louisiana.

*Date of Filing*—the *date of filing*, reporting receipt in the office shall be the date the document is received in the office.

*Days* (when used to determine a period allowed for filing)—the number of calendar *days*. If the final day of a time period falls on a Saturday, Sunday, holiday, or other day that the office is officially closed, then the period of filing shall be extended to the next day that the office is officially opened.

*Directors*—the assistant secretary of the Department of Labor responsible for workers' compensation administration.

*Document Size*—all filings not on forms approved by the office shall be submitted on 8 1/2" by 11" paper.

*Employee Notice*—the notice the employer is required to keep posted in the workplace.

*Form*—the forms required for notification to the office required by the Act.

*Medical Examiner*—any medical practitioner selected by the director for settling disputes.

*Office*—the Office of Workers' Compensation Administration in the Department of Labor.

*Penalty*—the percentages of additional payment required by section 1201 B of Act 1, 1983 Extraordinary Session.

*Rehabilitation*—the program designed to help an injured worker reenter the workplace.

AUTHORITY NOTE: Promulgated in accordance with R.S. 23:1021.

HISTORICAL NOTE: Promulgated by the Department of Labor, Office of Workers' Compensation Administration, LR 11:776 (August 1985), amended by the Department of Employment and Training, LR 17:358 (April 1991).

**§105. Forms**

A. The following forms are prescribed for use as required by the Workers' Compensation Act and these rules.

1. Form LDOL-WC-1007, Employer's Report of Occupational Injury or Disease, shall be filed with the Office of Workers' Compensation and with the employer's insurer when required by R.S. 23:1306, or within seven days of the first mediation conference of a disputed claim for benefits, whichever comes first. Failure to file this form as required may be penalized pursuant to LAC 40:I.109.

2. Form LDOL-WC-1020, Employee's Monthly Report of Earnings, shall be filed with the employer's insurer by employees who receive workers' compensation indemnity disability benefits within 30 days of their job-related injury, and every 30 days thereafter as long as they receive workers' compensation indemnity disability benefits. This form does not have to be filed by employees who only have received medical benefits. Failure to file this form as required may result in a suspension of benefits.

3. Form LDOL-WC-1025

a. Form LDOL-WC-1025, Employee and Employer Certificate of Compliance, shall be filed with the employer's insurer after Form LDOL-WC-1007 has been filed with the Office of Workers' Compensation. Employees who fail to file

## LABOR AND EMPLOYMENT

this form as required are subject to a penalty of \$500, payable to the insurer.

b. Form LDOL-WC-1025, Employee and Employer Certificate of Compliance, shall be filed with the employer's insurer by employees within 14 days of their receipt of the form, after Form LDOL-WC-1007 has been filed with the Office of Workers' Compensation. Employees who fail to file this form as required may have their benefits suspended; after this form is filed, employees are entitled to all suspended benefits, if otherwise eligible for benefits.

4. Form LDOL-WC-1026, Employee's Quarterly Report of Earnings, shall be filed with the employer's insurer by employees within 14 days of receipt of the form. This form does not have to be filed by employees who only have received medical benefits, or by employees who have timely filed all necessary LDOL-WC-1020 Forms. Employees who fail to file this form as required may have their benefits suspended; after this form is filed, employees are entitled to all suspended benefits, if otherwise eligible for benefits.

### 5. Form LDOL-WC-1017A

a. Form LDOL-WC-1017A, Employer's Report of Occupational Injury and Illness Quarterly Summary, shall be filed with the Office of Workers' Compensation by the last day of the first month of the succeeding quarter by all employers with 11 or more employees at any one time in the prior calendar year.

b. The following employers are exempt from the requirements of §105.A.5.a [also identified by their Standard Industrial Classification Codes (SIC Codes)]:

- i. agricultural production (SIC 01);
- ii. agricultural services (SIC 07);
- iii. automotive dealers and gasoline service stations (SIC 55);
- iv. apparel and accessory stores (SIC 56);
- v. furniture, home furnishings, and equipment stores (SIC 57);
- vi. eating and drinking places (SIC 58);
- vii. miscellaneous retail (SIC 59);
- viii. banking (SIC 60);
- ix. credit agencies other than banks (SIC 61);
- x. security, commodity brokers, and services (SIC 62);
- xi. insurance (SIC 63);
- xii. insurance agents, brokers, and services (SIC 64);
- xiii. real estate (SIC 65);
- xiv. holding and other investment offices (SIC 67);
- xv. personal services (SIC 72);
- xvi. business services (SIC 73);

- xvii. motion pictures (SIC 78);
- xviii. legal services (SIC 81);
- xix. educational services (SIC 82);
- xx. social services (SIC 83);
- xxi. museums, botanical, and zoological gardens (SIC 84);
- xxii. membership organizations (SIC 86);
- xxiii. engineering, accounting, research and management (SIC 87);
- xxiv. private households (SIC 88);
- xxv. miscellaneous services (SIC 89);
- xxvi. offices and clinics of doctors of medicine (SIC 8011);
- xxvii. offices and clinics of dentists (SIC 8021);
- xxviii. offices and clinics of doctors of osteopathy (SIC 8031);
- xxix. offices and clinics of chiropractors (SIC 8041);
- xxx. offices and clinics of optometrists (SIC 8042);
- xxxi. offices and clinics of podiatrists (SIC 8043);
- xxxii. offices and clinics of health practitioners, not elsewhere classified (SIC 8049);
- xxxiii. medical laboratories (SIC 8071);
- xxxiv. dental laboratories (SIC 8072);
- xxxv. home health care services (SIC 8082);
- xxxvi. kidney dialysis centers (SIC 8092);
- xxxvii. specialty outpatient facilities, not elsewhere classified (SIC 8093);
- xxxviii. health and allied services, not elsewhere classified (SIC 8099).

c. Failure to file this form as required may be penalized pursuant to LAC 40:I.109.

**AUTHORITY NOTE:** Promulgated in accordance with R.S. 23:1021.

**HISTORICAL NOTE:** Promulgated by the Department of Labor, Office of Workers' Compensation, LR 11:776 (August 1985), amended by the Department of Employment and Training, LR 17:358 (April 1991), amended by the Department of Labor, Office of Workers' Compensation, LR 22:221 (March 1996), LR 22:992 (October 1996).

### §109. Compliance Penalty

A. Unless otherwise provided for in the rules of the Office of Workers' Compensation, a person or entity that fails to comply with any rule or regulation adopted under the provisions of the Workers' Compensation Act may be penalized with a fine not to exceed \$500.

B. A person or entity may appeal any penalty imposed pursuant to this rule by filing a Disputed Claim Form,



LDOL-WC-1008, in the district where the person or entity is located or in Baton Rouge, LA. All such appeals shall be de novo. Any penalty imposed pursuant to this rule becomes final and may be pursued for collection unless such an appeal is filed within 30 days of the notice of the penalty.

**AUTHORITY NOTE:** Promulgated in accordance with R.S. 23:1291(B)(13).

**HISTORICAL NOTE:** Promulgated by the Department of Labor, Office of Workers' Compensation Administration, LR 11:776 (August 1985), amended by the Department of Employment and Training, Office of Workers' Compensation, LR 17:358 (April 1991), amended by the Department of Labor, Office of Workers' Compensation, LR 22:221 (March 1996), repromulgated LR 22:285 (April 1996), amended LR 22:992 (October 1996).

### §111. Restricted Work Notification

A. Every employer of more than 10 employees who is subject to record keeping under the provisions of U.S.C. Section 655 shall, within 90 days of any occupational death of an employee, any nonfatal occupational illness, or any nonfatal occupational injury involving either loss of consciousness, restriction of work or motion, transfer to another job, or medical treatment other than first aid, report to the statistical data section of the office on Form OSHA-200.

**AUTHORITY NOTE:** Promulgated in accordance with R.S. 23:1292.

**HISTORICAL NOTE:** Promulgated by the Department of Labor, Office of Workers' Compensation Administration, LR 11:776 (August 1985), amended by the Department of Employment and Training, LR 17:358 (April 1991).

## Chapter 3. Electronic Billing

### §301. Purpose

A. The purpose of this Rule is to provide a legal framework for electronic billing, processing, and payment of medical services and products provided to an injured employee and data reporting subject to R.S. 23:1203.2. It is the goal of the OWCA that electronic billing in Louisiana will follow formats that adhere to national standards and industry practices so as to minimize any customization specific to Louisiana. However, electronic billing in the workers compensation environment requires additional consideration for the required medical records (electronic attachments). At the time of promulgation, electronic attachments are not commonly used outside of the workers compensation environment. While the purpose of R.S. 23:1203.2 and these accompanying rules are to implement electronic billing in Louisiana, it is recognized that not all healthcare providers will immediately have the systems and processes to accommodate electronic billing and electronic attachments; therefore, participation in electronic medical billing as established in these rules is consistent with R.S. 23:1203.2 and is voluntary for healthcare providers.

**AUTHORITY NOTE:** Promulgated in accordance with R.S. 23:1203.2.

**HISTORICAL NOTE:** Promulgated by the Louisiana Workforce Commission, Office of Workers' Compensation, LR 37:3542 (December 2011).

### §303. Definitions

A. For the purposes of this Rule the following definitions shall apply.

*Agent*—broadly construed to mean any person or entity that performs medical bill related processes for the insurance carrier responsible for the bill. These processes include, but are not limited to, reporting to government agencies, electronic transmission, forwarding, or receipt of documents, review of reports, adjudication of bill, and final payment.

*Business Day*—Monday through Friday, excluding days on which a holiday is observed by this state.

*Clearinghouse*—a public or private entity, including a billing service, re-pricing company, community health management information system or community health information system, and "value-added" networks and switches, that is an agent of either the insurance carrier or provider and may perform the following functions:

a. processes or facilitates the processing of medical billing information received from a client in a nonstandard format or containing nonstandard data content into standard data elements or a standard transaction for further processing of a bill related transaction; or

b. receives a standard transaction from another entity and processes or facilitates the processing of medical billing information into nonstandard format or nonstandard data content for a client entity.

*CMS*—the Centers for Medicare and Medicaid Services of the U.S. Department of Health and Human Services.

*Complete Electronic Medical Bill*—a medical bill that meets all of the following criteria:

a. it is submitted in the correct uniform billing format, with the correct uniform billing code sets, transmitted in compliance with the format requirements described in this Rule;

b. the bill and electronic attachments provide all information required under R.S. 23:1203.2; and

c. the health care provider has provided all information that insurance carrier requested under Title 40 of the *Louisiana Administrative Code* for purposes of processing the bill.

*Electronic*—a communication between computerized data exchange systems that complies with the standards enumerated in this Rule.

*Electronic Medical Billing and Payment Companion Guide*—a separate document which gives detailed information for electronic billing and payment. The guide outlines the workers' compensation industry national standards and Louisiana jurisdictional procedures necessary for engaging in electronic data interchange (EDI) and specifies clarifications where applicable.

*Health Care Provider*—is defined in R.S. 23:1021.

*Health Care Provider Agent*—a person or entity that contracts with a health care provider establishing an agency relationship to process bills for services provided by the

health care provider under the terms and conditions of a contract between the agent and health care provider. Such contracts may permit the agent to submit bills, request reconsideration, and receive reimbursement for the health care provider services billed.

*Implementation Guide*—a published document for national electronic standard formats as defined in Section 305 of this Chapter that specifies data requirements and data transaction sets.

*Insurance Carrier*—the insurer legally responsible for paying the medical bills under workers' compensation, or an agent of this entity.

*National Provider Identification Number* or *NPI*—the unique identifier assigned to a health care provider or health care facility by the secretary of the United States Department of Health and Human Services.

*Supporting Documentation*—documents necessary for the insurance carrier or its agent to process a bill. These include, but are not limited to, any records as required by Title 40 of the *Louisiana Administrative Code*.

AUTHORITY NOTE: Promulgated in accordance with R.S. 23:1203.2.

HISTORICAL NOTE: Promulgated by the Louisiana Workforce Commission, Office of Workers' Compensation, LR 37:3542 (December 2011).

### **§305. Formats for Electronic Medical Bill Processing**

A. Where mandated for insurance carriers, beginning July 1, 2013 for electronic transmissions, the following electronic medical bill processing standards shall be used.

#### 1. Billing

a. *Professional Billing*—the ASC X12 Standards for Electronic Data Interchange Technical Report Type 3, Health Care Claim: Professional (837), May 2006, ASC X12, 005010X222 and Type 3 Errata to Health Care Claim: Professional (837), June 2010, ASC X12, 005010X222A1.

b. *Institutional/Hospital Billing*—the ASC X12 Standards for Electronic Data Interchange Technical Report Type 3, Health Care Claim: Institutional (837), May 2006, ASC X12N/005010X223, Type 1 Errata to Health Care Claim: Institutional (837), ASC X12 Standards for Electronic Data Interchange Technical Report Type 3, October 2007, ASC X12N/005010X223A1, and Type 3 Errata to Health Care Claim: Institutional (837), June 2010, ASC X12, 005010X223A2.

c. *Dental Billing*—the ASC X12 Standards for Electronic Data Interchange Technical Report Type 3, Health Care Claim: Dental (837), May 2006, ASC X12N/005010X224, Type 1 Errata to Health Care Claim: Dental (837), ASC X12 Standards for Electronic Data Interchange Technical Report Type 3, October 2007, ASC X12N/005010X224A1, and Type 3 Errata to Health Care Claim: Dental (837), June 2010, ASC X12, 005010X224A2.

d. *Retail Pharmacy Billing*—the Telecommunication Standard Implementation Guide, Version D, Release 0 (Version D.0), August 2007, National Council for Prescription Drug Programs and the Batch

Standard Batch Implementation Guide, Version 1, Release 2 (Version 1.2), January 2006, National Council for Prescription Drug Programs.

#### 2. Acknowledgment

a. Electronic responses to ASC X12N 837 transactions:

i. the ASC X12 Standards for Electronic Data Interchange TA1 Interchange Acknowledgment contained in the standards adopted under Paragraph A.1 of this Section;

ii. the ASC X12 Standards for Electronic Data Interchange Technical Report Type 3, Implementation Acknowledgment for Health Care Insurance (999), June 2007, ASC X12N/005010X231; and

iii. the ASC X12 Standards for Electronic Data Interchange Technical Report Type 3, Health Care Claim Acknowledgment (277CA), January 2007, ASC X12N/005010X214.

b. Electronic responses to NCPDP transactions:

i. the response contained in the standards adopted under Paragraph A.1 of this Section.

3. *Remittance*—the ASC X12 Standards for Electronic Data Interchange Technical Report Type 3, Health Care Claim Payment/Advice (835), April 2006, ASC X12N/005010X221 and Type 3 Errata to Health Care Claim Payment/Advice (835), June 2010, ASC X12, 005010X221A1.

4. *Documentation* submitted with an electronic medical bill in accordance with Section 309 of this Chapter (relating to medical documentation): ASC X12N Additional Information to Support a Health Claim or Encounter (275), February 2008, ASC X12, 005010X210.

B. Nothing in this Section shall prohibit insurance carriers and health care providers from using a direct data entry methodology for complying with these requirements, provided the methodology complies with the data content requirements of the adopted formats and these rules.

C. Insurance carriers and health care providers may exchange electronic data in a non-prescribed format by mutual agreement. All data elements required in the OWCA-prescribed formats must be present in a mutually agreed upon format.

D. The implementation specifications for the ASC X12N and the ASC X12 Standards for Electronic Data Interchange may be obtained from the ASC X12, 7600 Leesburg Pike, Suite 430, Falls Church, VA 22043; telephone (703) 970-4480; and fax (703) 970-4488. They are also available through the Internet at <http://store.X12.org>. A fee is charged for all implementation specifications.

E. The implementation specifications for the retail pharmacy standards may be obtained from the National Council for Prescription Drug Programs, 9240 East Raintree Drive, Scottsdale, AZ 85260; telephone (480) 477-1000; fax (480) 767-1042. They are also available through the internet at <http://www.ncdp.org>. A fee is charged for all implementation specifications.

F. Whenever the formats enumerated in Subsection A of this Section, for billing, acknowledgement, remittance, and documentation are replaced with a newer version, the most recent standard should be used. The requirement to use a new version shall commence on the effective date of the new version as published in the *Code of Federal Regulations*.

G. The OWCA shall develop the electronic medical billing and payment companion guide found in Section 306 of this Chapter.

AUTHORITY NOTE: Promulgated in accordance with R.S. 23:1310.1.

HISTORICAL NOTE: Promulgated by the Louisiana Workforce Commission, Office of Workers' Compensation, LR 37:3543 (December 2011), amended LR 39:331 (February 2013).

### **§306. Electronic Medical Billing and Payment Companion Guide**

#### A. Introduction and Overview

##### 1. HIPAA

a. The Administrative Simplification Act provisions of the federal Health Insurance Portability and Accountability Act of 1996 (HIPAA, Title II) include requirements that national standards for electronic health care transactions and national identifiers for health care providers (provider), health plans, and employers be established. These standards were adopted to improve the efficiency and effectiveness of the nation's health care system by encouraging the widespread use of electronic data interchange in health care. Additional information regarding the formats adopted under HIPAA is included in Chapter 2. Although workers compensation is excluded from HIPAA, these national standards encourage use of electronic medical billing for workers compensation claims in Louisiana.

##### 2. Louisiana Workforce Commission, Office of Workers' Compensation-Electronic Billing

a. Louisiana Workforce Commission, Office of Workers' Compensation, R.S. 23:1203.2 mandates that carriers accept electronic bills for medical goods and services. Payers other than carriers (self-insured employers or self-insured funds) may participate in electronic medical billing but are not mandated as of this time. The rules also provide that the regulations which establish electronic billing rules be consistent with HIPAA to the extent possible. If participating in electronic medical billing, the health care provider, health care facility, or third-party biller/assignee shall use the HIPAA adopted electronic transaction formats outlined in Title 40:I:Chapter 3 to submit medical or pharmacy bills to the appropriate payer associated with the employer of the injured employee to whom the services are provided.

b. In workers' compensation, the payer is the party responsible for providing benefits on behalf of the employer of the injured employee to whom the services are due. The payer, or its authorized agent, is to validate the electronic data interchange (EDI) file according to the guidelines provided in the prescribed national standard format implementation guide, this companion guide, and the jurisdictional data requirements. Problems associated with

the processing of the ASC X12 health care claim (837) EDI file are to be reported using acknowledgment transactions described in this companion guide. Problems associated with the processing of the NCPDP telecommunications D.0 bills are reported via the reject response transactions described in this companion guide. If mutually agreed upon, the payer will use the HIPAA-adopted electronic transaction formats to report explanations of payments, reductions, and denials to the health care provider, health care facility, or third-party biller/assignee. These electronic transaction formats include the ASC X12N/005010X221A1, health care claim payment/advice (835), and the NCPDP telecommunication D.0 paid response transaction or other formats pursuant to Title 40:I:Chapter 3.

c. Health care providers, health care facilities, or third-party biller/assignees, payers, clearinghouses, or other electronic data submission entities shall use this guideline in conjunction with the HIPAA-adopted ASC X12 type 3 technical reports (implementation guides) and the NCPDP telecommunication standard implementation guide version D.0. The ASC X12 type 3 technical reports (implementation guides) can be accessed by contacting the Accredited Standards Committee (ASC) X12, <http://store.x12.org/store/>. The NCPDP telecommunication standard implementation guide version D.0 is available from NCPDP at [www.ncdp.org](http://www.ncdp.org).

d. This guide outlines jurisdictional procedures necessary for engaging in electronic data interchange (EDI) and specifies clarifications where applicable. When coordination of a solution is required, Louisiana Workforce Commission, Office of Workers' Compensation will work with the IAIABC EDI Medical Committee and Provider to Payer Subcommittee to coordinate with national standard setting organizations and committees to address workers' compensation needs.

#### B. Louisiana Workforce Commission, Office of Workers' Compensation Requirements

1. Compliance. If a billing entity chooses to submit bills electronically, it must also be able to receive an electronic response from the payer pursuant to Title 40:I:Chapter 3. The electronic responses include electronic acknowledgments (required) and electronic remittance advices (explanation of review) (where mutually agreed upon). Electronic billing rules allow for providers and payers to use agents to meet the requirement of electronic billing, but these rules do not mandate the method of connectivity, or the use of, or connectivity to, clearinghouses or similar types of vendors. Nothing in this document prevents the parties from utilizing electronic funds transfer (EFT) to facilitate payment of electronically submitted bills. Use of EFT is governed by R.S. 23:1203.2(B)(2) and is not a pre-condition for electronic billing. If covered by R.S. 23:1203.2, health care providers, health care facilities, third-party biller/assignees, and payers must be able to exchange electronic bills in the prescribed standard formats and may exchange data in non-prescribed formats by mutual agreement. All jurisdictionally-required data content must be present in mutually agreed upon formats.

**LABOR AND EMPLOYMENT**

2. Agents. Electronic billing rules allow for health care providers and payers to use agents to accomplish the requirement of electronic billing. Payers and health care providers are responsible for the acts or omissions of their agents executed in the performance of services for their client’s payer or health care provider.

3. Privacy, Confidentiality, and Security. Health care providers, health care facilities, third-party biller/assignees, payers, and their agents must comply with all applicable federal and Louisiana acts, codes, or rules related to the privacy, confidentiality, security or similar issues.

4. National Standard Formats

a. The national standard formats for billing, remittance, and acknowledgments are those adopted by the federal Department of Health and Human Services rules (45 CFR Parts 160 and 162). The formats adopted under Louisiana Workforce Commission, Office of Workers’ Compensation, R.S. 23:1203.2, that are aligned with the current federal HIPAA implementation include:

- i. ASC X12N/005010X222A1—health care claim: professional (837);
- ii. ASC X12N/005010X223A2—health care claim: institutional (837);
- iii. ASC X12N/005010X224A2—health care claim: dental (837);
- iv. ASC X12N/005010X221A1—health care claim payment/advice (835);
- v. ASC X12N/005010X212—health care claim status request and response (276/277);
- vi. ASCX12N005010TA1—interchange acknowledgement;
- vii. ASCX12C005010X231—implementation acknowledgment for health care insurance (999);
- viii. ASCX12N005010X214—health care claim acknowledgment (277);
- ix. NCPDP telecommunication standard implementation guide version D.0; and
- x. NCPDP batch standard implementation guide 1.2.

b. These acknowledgment formats and the attachment format have not been adopted in the current HIPAA rules but are also based on ASC X12 standards.

i. The ASC X12N/005010X213—request for additional information (277) is used to request additional attachments that were not originally submitted with the electronic medical bill.

ii. The ASC X12N/005010X210—additional information to support a health care claim or encounter (275) is used to transmit electronic documentation associated with an electronic medical bill. The 005010X210 can accompany the original electronic medical bill, or may be sent in

response to a 005010X213—request for additional information.

c. The NCPDP telecommunication standard implementation guide version D.0 contains the corresponding request and response messages to be used for pharmacy transactions.

5. Louisiana Workforce Commission, Office of Workers’ Compensation Prescribed Formats

Format	Corresponding Paper Form	Function
005010X222A1	CMS-1500	Professional Billing
005010X223A2	UB-04	Institutional/Hospital Billing
005010X224A2	ADA-2006	Dental Billing
NCPDP D.0 and Batch 1.2	NCPDP WC/PC UCF	Pharmacy Billing
005010X221A1	None	Explanation of Review (EOR)
TA1 005010	None	Interchange Acknowledgment
005010X231	None	Transmission Level Acknowledgment
005010X214	None	Bill Acknowledgment

6. ASC X12 Ancillary Formats

a. Other formats not adopted by Louisiana Workforce Commission, Office of Workers’ Compensation rule are used in ancillary processes related to electronic billing and reimbursement. The use of these formats is voluntary, and the companion guide is presented as a tool to facilitate their use in workers’ compensation.

Format	Corresponding Process	Function
005010X210	Documentation/Attachments	Documentation/Attachments
005010X213	Request for Additional Information	Request for Medical Documentation
005010X214	Health Claim Status Request and Response	Medical Bill Status Request and Response

7. Companion Guide Usage

a. Louisiana Workforce Commission, Office of Workers’ Compensation workers’ compensation implementation of the national standard formats aligns with HIPAA usage and requirements in most circumstances. This jurisdictional companion guide is intended to convey information that is within the framework of the ASC X12 type 3 technical reports (implementation guides) and NCPDP telecommunication standard implementation guide version D.0 adopted for use. This jurisdictional companion guide is not intended to convey information that in any way exceeds the requirements or usages of data expressed in the ASC X12 type 3 technical reports (implementation guides) or NCPDP telecommunication standard implementation guide version D.0. The jurisdictional companion guide, where applicable, provides additional instruction on situational implementation factors that are different in workers’ compensation than in the HIPAA implementation.

b. When the workers’ compensation application situation needs additional clarification or a specific code value is expected, the companion guide includes this information in a table format. Shaded rows represent “segments” in the ASC X12 type 3 technical reports

(implementation guides). Non-shaded rows represent “data elements” in the ASC X12 type 3 technical reports (implementation guides). An example is provided in the following table.

Loop	Segment or Element	Value	Description	Louisiana Workforce Commission, Office of Workers’ Compensation Instructions
2000B	SBR		Subscriber Information	In workers’ compensation, the Subscriber is the Employer.
	SBR04		Group or Plan Name	Required when the Employer Department Name/Division is applicable and is different than the Employer reported in Loop 2010BA NM103.
	SBR09	WC	Claim Filing Indicator Code	Value must be ‘WC’ to indicate workers’ compensation bill.

c. Detailed information explaining the various components of the use of loops, segments, data elements, and conditions can be found in the appropriate ASC X12 type 3 technical reports (implementation guides).

d. The ASC X12 type 3 technical reports (implementation guides) also include elements that do not relate directly to workers’ compensation processes, for example, coordination of benefits. If necessary, the identification of these loops, segments, and data elements can be described in the trading partner agreements to help ensure efficient processing of standard transaction sets.

8. Description of ASC X12 Transaction Identification Numbers. The ASC X12 transaction identification requirements are defined in the appropriate ASC X12 type 3 technical reports (implementation guides), available through the Accredited Standards Committee (ASC) X12, <http://store.x12.org>. The Louisiana Workforce Commission, Office of Workers’ Compensation has provided the following additional information regarding transaction identification number requirements.

a. Sender/Receiver Trading Partner Identification. Workers’ compensation standards require the use of the federal employer identification number (FEIN) or other mutually agreed upon identification numbers to identify trading partners (sender/receiver) in electronic billing and reimbursement transmissions. Trading partners will exchange the appropriate and necessary identification numbers to be reported based on the applicable transaction format requirements.

b. Payer Identification. Payers and their agents are also identified through the use of the FEIN or other mutually agreed upon identification number. Payer information is available through direct contact with the payer. The payer identification information is populated in loop 2010BB for 005010X222A1, 005010X223A2, and 005010X224A2 transactions.

i. Health care providers will need to obtain payer identification information from their connectivity trading

partner agent (i.e. clearinghouses, practice management system, billing agent and/or other third party vendor) if they are not directly connecting to a payer.

c. Health Care Provider Identification. Health care provider roles and identification numbers are addressed extensively in the ASC X12 type 3 technical reports (implementation guides). However, it is noted that in the national transaction sets most health care providers are identified by the national provider identification number (NPI), and secondary identification numbers are generally not transmitted.

d. Injured Employee Identification. The injured employee is identified by name, Social Security number, date of birth, date of injury, and workers’ compensation claim number (see below).

i. The injured employee (patient’s) identification number is submitted using the property and casualty patient identifier REF segment in loop 2010CA.

e. Claim Identification. The workers’ compensation claim number assigned by the payer is the claim identification number. This claim identification number is reported in the REF segment of loop 2010CA, property and casualty claim number.

i. The ASC X12N technical report type 3 (implementation guides) instructions for the property and casualty claim number REF segments require the health care provider, health care facility, or third-party biller/assignee to submit the claim identification number in the 005010X222A1, 005010X223A2 and 005010X224A2 transactions.

f. Bill Identification. The ASC X12N technical report type 3 (implementation guides) refers to a bill as a “claim” for electronic billing transactions. This Louisiana Workforce Commission, Office of Workers’ Compensation companion guide refers to these transactions as “bill” because in workers’ compensation, a “claim” refers to the full case for a unique injured employee and injury. The health care provider, health care facility, or third-party biller/assignee, assigns a unique identification number to the electronic bill transaction. For 005010X222A1, 005010X223A2, and 005010224A2 transactions, the bill transaction identification number is populated in loop 2300 claim information CLM health claim segment CLM01 claim (bill) submitter’s identifier data element. This standard HIPAA implementation allows for a patient account number but strongly recommends that submitters use a completely unique number for this data element on each individual bill.

g. Document/Attachment Identification. The 005010X210 is the standard electronic format for submitting electronic documentation and is addressed in a later chapter of the Louisiana Workforce Commission, Office of Workers’ Compensation electronic billing and payment companion guide. Bills containing services that require supporting documentation as defined Louisiana Workforce Commission, Office of Workers’ Compensation, R.S. 23:1203.2 must be properly annotated in the PWK attachment segment. Bill transactions that include services that require documentation and are submitted without the

## LABOR AND EMPLOYMENT

PWK annotation documentation will be rejected. Documentation to support electronic medical bills may be submitted by facsimile (fax), electronic mail (email), electronic transmission using the prescribed format, or by a mutually agreed upon format between providers and payers. Documentation related to the electronic bill must be submitted within five business days of submission of the electronic medical bill and must identify the following elements:

- i. patient name (injured employee);
- ii. employer name (if available);
- iii. payer name;
- iv. date of service;
- v. date of injury;
- vi. claim number (if known);
- vii. unique attachment indicator number.

h. The PWK segment and the associated documentation identify the type of documentation through the use of ASC X12 standard report type codes. The PWK segment and the associated documentation also identify the method of submission of the documentation through the use of ASC X12 report transmission codes. A unique attachment indicator number shall be assigned to all documentation. The attachment indicator number populated on the document shall include the report type code, the report transmission code, the attachment control qualifier (AC) and the attachment control number. For example, operative note (report type code OB) sent by fax is identified as OBFXAC12345. The combination of these data elements will allow a claim administrator to appropriately match the incoming attachment to the electronic medical bill.

9. Payer Validation Edits. Payers may apply validation edits based on Louisiana Workforce Commission, Workers' Compensation Office of Workers' Compensation ebill regulations, Louisiana electronic medical billing and payment companion guide and ASC X12N—technical reports type 3 (TR3s) requirements. Payers use the 005010X214 transaction, referred to in this companion guide as an acknowledgment, to communicate transaction (individual bill) rejections for ASC X12-based electronic medical bills. Error rejection codes are used to indicate the reason for the transaction rejection.

10. Description of Formatting Requirements. The ASC X12 formatting requirements are defined in the ASC X12 type 3 technical reports (implementation guides), appendices a.1, available through the Accredited Standards Committee (ASC) X12, <http://store.x12.org>. The Louisiana Workforce Commission, Office of Workers' Compensation has provided the following additional information regarding formatting requirements.

a. The NCPDP telecommunication D.0 formatting requirements are defined in the NCPDP telecommunication standard implementation guide version D.0, available at <http://www.ncdp.org>.

11. ASC X12—Hierarchical Structure. For information on how the ASC X12—hierarchical structure works, refer to section 2.3.2.1 HL segment of the ASC X12 type 3 technical reports (implementation guides), available through the Accredited Standards Committee (ASC) X12, <http://store.x12.org>.

12. Description of ASC X12—Transmission/Transaction Dates. The ASC X12 required transmission/transaction dates are defined in the ASC X12 type 3 technical reports (implementation guides) available through the Accredited Standards Committee (ASC) X12, <http://store.x12.org>. The Louisiana Workforce Commission, Office of Workers' Compensation has provided additional information regarding specific transmission/transaction identification requirements.

13. Date Sent/Invoice Date. In the manual paper medical bill processing model, the paper bill includes a date the bill was generated, to verify timely filing. For electronic billing, the invoice date is the date sent, which is reflected in the interchange control header ISA segment interchange date. the date in the control header ISA segment must be the actual date the transmission is sent.

14. Date Received. For medical bill processing purposes, the date received is the date the payer or its agent received the complete medical bill transaction. The date received is used to track timely processing of electronic bills, electronic reconsideration/appeal transactions, acknowledgment transactions, and timeliness of payments.

15. Paid Date. When the 005010X221A1 transaction set is used to electronically provide the remittance advice, the paid date is the date contained in BPR 16, check issue or EFT effective date, in the financial information segment.

16. Description of Code Sets. Code sets utilized in electronic billing and reimbursement and other ancillary processes are prescribed by the applicable ASC X12 type 3 technical reports (implementation guides), NCPDP Implementation Guide, Louisiana Workforce Commission, Office of Workers' Compensation rule, and this companion guide. The code sets are maintained by multiple standard setting organizations. Participants are required to utilize current valid codes based on requirements contained in the applicable implementation guide. The validity of the various codes may be based on the date of service (e.g., procedure and diagnosis codes) or based on the date of the electronic transaction (e.g., claim adjustment reason codes).

17. Participant Roles. Roles in the HIPAA implementation guides are generally the same as in workers' compensation. The employer, insured, injured employee, and patient are roles that are used differently in workers' compensation and are addressed later in this Section.

a. Trading Partner. Trading partners are entities that have established EDI relationships and that exchange information electronically either in standard or mutually agreed-upon formats. Trading partners can be both senders and receivers, depending on the electronic process involved (i.e. billing or acknowledgment).

b. **Sender.** A sender is the entity submitting a transmission to the receiver, or its trading partner. The health care provider, health care facility, or third-party biller/assignee, is the sender in the 005010X222A1, 005010X223A2 and 005010X224A2 electronic billing transactions. The payer, or its agent, is the sender in the 005010X214, 005010X231 or 005010X221A1 electronic acknowledgment or remittance transactions.

c. **Receiver.** A receiver is the entity that accepts a transmission submitted by a sender. The health care provider, health care facility, or third-party biller/assignee, is the receiver in the 005010X214, 005010X231 or 005010X221A1 electronic acknowledgment or remittance transactions. The payer, or its agent, is the receiver in the 005010X222A1, 005010X223A2, and 005010X224A2 electronic billing transactions.

d. **Employer.** The employer, as the policyholder of the workers' compensation insurance coverage or covered through self-insurance, is considered the subscriber in the workers' compensation implementation of the HIPAA electronic billing and reimbursement formats.

e. **Subscriber.** The subscriber or insured is the individual or entity that purchases or is covered by an insurance policy or covered through self-insurance. In this implementation, the workers' compensation insurance policy or self-insurance contract is obtained by the Employer, who is considered the subscriber.

f. **Insured.** The insured or subscriber is the individual or entity that purchases or is covered by an insurance policy or self-insurance contract. In group health, the insured may be the patient, the spouse or the parent of the patient. In this workers' compensation implementation, the Employer is considered the insured entity.

g. **Injured Employee.** In workers' compensation, the injured employee, as the person who has been injured on the job or has a work related illness, is always considered to be the patient. Thus, the relationship between the insured and the patient is always an employer/employee relationship, as opposed to group health, where there are many possible relationships a patient may have to the insured. For example, in a group health setting, the patient may be the insured, or may be the child or spouse of the insured, but the child or spouse of the injured employee will never be a covered patient in workers' compensation.

h. **Patient.** The patient is the person receiving medical services. In the workers' compensation implementation of electronic billing and reimbursement processes, the patient is considered the injured employee.

18. **Health Care Provider Agent/Payer Agent Roles.** Electronic billing and reimbursement rules include provisions that allow for providers and payers to utilize agents to comply with the electronic billing (eBill) requirements. Billing agents, third party administrators, bill review companies, software vendors, data collection agents, and clearinghouses are examples of companies that may have a role in eBill. Payers and health care providers are responsible for the acts or omissions of their agents executed in the performance of services for the payer or health care

provider. Under the eBill rules, carriers must be able to receive medical billing from health care providers. Payers may establish direct electronic connections to health care providers or may use agents to perform eBill functions. The rules do not mandate the use of, or regulate the costs of, agents performing eBill functions. Providers and payers are not required by Louisiana Workforce Commission, Office of Workers' Compensation rule to establish connectivity with a clearinghouse or to utilize a specific media/method of connectivity (i.e. secured file transfer protocol [SFTP]). By mutual agreement, use of non-standard formats between the health care provider, health care facility, or third-party biller/assignee and the payer is permissible. The eBill rules do not regulate the formats utilized between providers and their agents, or payers and their agents, or the method of connectivity between those parties.

19. **Duplicate, Appeal/Reconsideration, and Corrected Bill Resubmissions**

a. **Claim Resubmission Code—837 Billing Formats.** Health care providers will identify resubmissions of prior medical bills (not including duplicate original submissions) by using the claim frequency type code of 7 (resubmission/replacement). The value is populated in loop 2300 claim information CLM health claim segment CLM05-3 claim frequency type code of the 005010X222A1, 005010X223A2 and 005010X224A2 electronic billing transactions. When the payer has provided the payer claim control number it had assigned to the bill being replaced, the health care provider must also use this number in its response to the previous bill submission. This information is populated in loop 2300 claim information REF payer claim control number of the 005010X222A1, 005010X223A2 and 005010X224A2 electronic billing transactions.

i. On electronically submitted medical bills, health care providers must also populate the appropriate NUBC condition code to identify the type of resubmission. Condition codes provide additional information to the payer when the resubmitted bill is a request for reconsideration or a new submission after receipt of a decision from the Louisiana Workforce Commission, Office of Workers' Compensation or other administrative proceeding, such as a judicial review. Based on the instructions for each bill type, the condition code is submitted in the HI segment for 005010X222A1 and 005010X223A2 transactions and in the NTE segment for the 005010X224A2 transaction. (The use of the NTE segment is at the discretion of the sender.)

ii. The reconsideration claim frequency type code '7' is used in conjunction with the payer claim control number that the claim administrator had assigned to the bill in response to the previous bill submission. This information is populated in loop 2300 claim information REF payer claim control number of the 005010X222A1, 005010X223A2, and 005010X224A2 electronic billing transactions. The NUBC instruction for the use of claim frequency type codes can be referenced on the NUBC website at [http://www.nubc.org/FL4forWeb2\\_RO.pdf](http://www.nubc.org/FL4forWeb2_RO.pdf). The CMS-required bill processing documentation for adjustments can be referenced at <http://www.cms.hhs.gov/manuals/downloads/clm104c01.pdf>.

b. Duplicate Bill Transaction Prior To Payment

i. A condition code 'W2' (duplicate of the original bill) is required when a provider submits a bill that is a duplicate. The condition code is submitted based on the instructions for each bill type. It is submitted in the HI segment for professional and institutional transactions and in the NTE segment for dental transactions. (The use of the NTE segment is at the discretion of the sender.) The duplicate bill must be identical to the original bill, with the exception of the added condition code. No new dates of service or itemized services may be included on the duplicate bill.

Duplicate Bill Transaction
<ul style="list-style-type: none"> <li>• CLM05-3 = Identical value as original. Cannot be '7'.</li> <li>• Condition codes in HI/K3 are populated with a condition code qualifier 'BG' and code value: 'W2' = Duplicate.</li> <li>• NTE Example: NTE*ADD*BGW2</li> <li>• Payer Claim Control Number does not apply.</li> <li>• The resubmitted bill must be identical to the original bill, except for the 'W2' condition code. No new dates of service or itemized services may be included on the duplicate bill.</li> </ul>

ii. A health care duplicate bill transaction shall be submitted no earlier than 30 calendar days after the payer has acknowledged receipt of a complete electronic bill transaction or prior to receipt of a 005010X221A1 transaction.

iii. The payer may reject a bill transaction with a condition code W2 indicator if

- (a). the duplicate bill is received within thirty (30) calendar days after acknowledgment;
- (b). the bill has been processed and the 005010X221A1 transaction has been generated; or
- (c). the payer does not have a corresponding accepted original transaction with the same bill identification numbers.

iv. If the payer does not reject the duplicate bill transaction within two business days, the duplicate bill transaction may be denied for the reasons listed above through the use of the 005010X221A1 transaction or through a non-electronic EOR process.

c. Corrected Bill Transactions

i. A replacement bill is sent when a data element on the original bill was either not previously sent or needs to be corrected.

ii. When identifying elements change, the correction is accomplished by a void and re-submission process: a bill with CLM05-3 = '8' (void) must be submitted to cancel the incorrect bill, followed by the submission of a new original bill with the correct information.

iii. Billers should not replace or void a prior bill until that prior submitted bill has reached final adjudication status, which can be determined from the remittance advice, a web application, when showing a finalized code under claim status category 277, or by non-electronic means.

Corrected Bill Transaction
<ul style="list-style-type: none"> <li>• CLM05-3 = '7' indicates a replacement bill.</li> <li>• Condition codes of 'W2' to 'W5' in HI/K3 are not used.</li> <li>• REF*F8 includes the Payer Claim Control Number, if assigned by the payer.                         <ul style="list-style-type: none"> <li>• A corrected bill shall include the original dates of service and the same itemized services rendered as the original bill.</li> <li>• When identifying elements change, the correction is accomplished by a void and re-submission process. A bill with CLM05-3 = '8' (Void) must be submitted to cancel the incorrect bill, followed by the submission of a new original bill with the correct information.</li> </ul> </li> </ul>

iv. The payer may reject a revised bill transaction if:

- (a). the payer does not have a corresponding adjudicated bill transaction with the same bill identification number; or
- (b). there is incorrect billing documentation for an adjustment based on CMS guidelines (inappropriate changed data).

v. If the payer does not reject the revised bill transaction within two business days, the revised bill transaction may be denied for the reasons listed above through the use of the 005010X221A1 transaction or through a non-electronic EOR process.

d. Appeal/Reconsideration Bill Transactions. Appeal/reconsideration of disputed disbursements and denials are outlined and detailed in LAC 40, Chapter 51, §5149 and R.S. 23:1034.2(F). Additional information can also be found on the Louisiana Workforce Commission, Office of Workers' Compensation website, [www.laworks.net/WorkersComp/OWC\\_MainMenu.asp](http://www.laworks.net/WorkersComp/OWC_MainMenu.asp).

20. Balance Forward Billing. Balance forward bills are bills that are either for a balance carried over from a previous bill or are for a balance carried over from a previous bill along with charges for additional services. Balance forward billing is not permissible.

21. Louisiana Workforce Commission, Office of Workers' Compensation and Workers' Compensation Specific Requirements. The requirements in this Section identify Louisiana Workforce Commission, Office of Workers' Compensation workers' compensation specific requirements that apply to more than one electronic format. Requirements that are related to a specific format are identified in the chapter related to that format.

a. Claim Filing Indicator. The claim filing indicator code for workers' compensation is 'WC' populated in loop 2000B subscriber information, SBR subscriber information segment field SBR09 for the 005010X222A1, 005010X223A2, or 005010X224A2 transactions.

b. Transaction Set Purpose Code. The transaction set purpose code in the transaction set header BHT beginning of hierarchical transaction segment field BHT02 in 005010X222A1, 005010X223A2, or 005010X224A2 transactions is designated as '00' original. Payers are required to acknowledge acceptance or rejection of transmissions (files) and transactions (bills). Transmissions that are rejected by the payer and then corrected by the



provider are submitted, after correction, as ‘00’ original transmissions.

c. Transaction Type Code. The transaction type code in the transaction set header BHT beginning of hierarchical transaction segment field BHT06 in 005010X222A1, 005010X223A2, or 005010X224A2 transactions is designated as ‘CH’ chargeable. Currently, health care providers are not required to report electronic billing data to the Louisiana Workforce Commission, Office of Workers’ Compensation. Therefore, code ‘RP’ (reporting) is not appropriate for this implementation.

d. Louisiana Workers’ Compensation Specific Requirements that Relate to Multiple Electronic. The requirements in this Section identify Louisiana workers’ compensation specific requirements that apply to more than one electronic format. Requirements that are related to a specific format are identified in the chapter related to that format.

e. NCPDP Telecommunication Standard D.0 Pharmacy Formats. Issues related to electronic pharmacy billing transactions are addressed in chapter 6 companion guide NCPDP D.0 pharmacy.

Loop	Segment	Description	Louisiana Companion Guide Workers’ Compensation Comments or Instructions
1000A	PER	Submitter EDI Contact Information	Communication Number Qualifier must be ‘TE’—Telephone Number
2000B	SBR	Subscriber Information	In workers’ compensation, the Subscriber is the Employer.
2000B	SBR04	Name	In workers’ compensation, the group name is the employer of the patient/employee.
2000B	SBR09	Claim Filing Indicator Code	Value must be ‘WC’ for workers’ compensation
2010BA		Subscriber Name	In workers’ compensation, the Subscriber is the Employer.
2010BA	NM102	Entity Type Qualifier	Value must be ‘2’ non-person
2010BA	NM103	Name Last or Organization Name	Value must be the name of the Employer
2010BA	REF	Property and Casualty Claim Number	Enter the claim number if known. If not known, then enter the default value of “unknown”.
2000C	PAT01	Individual Relationship Code	Value must be ‘20’ Employee
2010CA	REF	Property and Casualty Claim Number	Enter the claim number if known. If not known, then enter the default value of “unknown”.
2010CA	REF	Property and Casualty Patient Identifier	Required
2010CA	REF01	Reference Identification Qualifier	Value must be ‘SY’ (Social Security Number)
2010CA	REF02	Reference Identification	Value must be the patient’s Social Security Number. When applicable, utilize ‘999999999’ as a default value where the social security number is not known.

Loop	Segment	Description	Louisiana Companion Guide Workers’ Compensation Comments or Instructions
2300	CLM11	Related Causes Information	One of the occurrences in CLM11 must have a value of ‘EM’—Employment Related
2300	DTP	Date—Accident	Required when the condition reported is for an occupational accident/injury
2300	DTP	Date—Disability Dates	Do not use Segment. Leave blank.
2300	DTP	Date—Property And Casualty Date Of First Contact	Do not use Segment. Not Applicable to LA regulations
2300	PWK	Claim Supplemental Information	Refer to the companion guide for instruction regarding Documentation/Medical Attachment Requirements.
2300	PWK01	Report Type Code	Use appropriate 005010 Report Type Code.
2300	PWK06	Attachment Control Number	Enter the Attachment Control Number Example PWK*OB*BM***AC*DMN 0012~
2300	K3	File Information	State Jurisdictional Code is expected here.
2300	K301	Fixed Format Information	Jurisdiction State Code (State of Compliance Code) Required when the provider knows the state of Jurisdiction is different than the billing provider’s state (2010AA/N4/N402). Enter the state code qualifier ‘LU’ followed by the state code. For example, ‘LULA’ indicates the medical bill is being submitted under Louisiana medical billing requirements.
2300	HI	Condition Information	For workers’ compensation purposes, the National Uniform Billing Committee and the National Uniform Claims Committee has approved the following condition code (W2) for resubmission of a duplicate of the original bill. • W2—Duplicate of the original bill Note: Do not use condition codes when submitting revised or corrected bills.

C. Companion Guide ASC X12N/005010X222A1—Health Care Claim: Professional (837)

1. Introduction and Overview. The information contained in this companion guide has been created for use in conjunction with the ASC X12N/005010X222A1—health care claim: professional (837) technical report type 3. It is not to be considered a replacement for the ASC X12N/005010X222A1—health care claim: professional (837) technical report type 3, but rather is to be used as an additional source of information. This companion guide is not, nor was it ever intended to be, a comprehensive guide to the electronic transaction requirements for each of the

LABOR AND EMPLOYMENT

Jurisdictions. The companion guide is intended to be used by Jurisdictions to develop and publish companion guides tailored to their regulatory environment that consistently apply the syntactical requirements of the ASC X12 type 3 technical reports. The ASC X12N/005010X222A1—health care claim: professional (837) technical report type 3 is available through the Accredited Standards Committee (ASC) X12, <http://store.x12.org>.

2. Purpose, Applicability, and Expected Implementation Date. The purpose of electronic billing (LAC 40:I.Chapter 3) is to provide a framework for electronic billing, processing, and payment of medical services and products provided to an injured employee and data reporting subject to R.S. 23:1203.2, mandated for insurance carriers, beginning July 1, 2013 for electronic submissions.

3. Trading Partner Agreements. The components of trading partner agreements that define other transaction parameters beyond the ones described in this companion guide (such as transmission parameters) remain the same; this companion guide is not intended to replace any of those components. The data elements transmitted as part of a trading partner agreement must, at a minimum, contain all the same required data elements found within the ASC X12 type 3 technical reports and the jurisdiction-specific companion guide. The trading partner agreement must not change the workers’ compensation field value designations as defined in the jurisdiction-specific companion guide.

4. Workers’ Compensation Health Care Claim: Professional Instructions. Instructions for Louisiana-specific requirements are also provided in Louisiana Workers’ Compensation requirements. The following table identifies the application/ instructions for Louisiana Workers’ Compensation that need clarification beyond the ASC X12 type 3 technical reports.

ASC X12N/005010X222A1			
Loop	Segment	Description	Louisiana Companion Guide Workers’ Compensation Comments or Instructions
2000C	PAT01	Individual Relationship Code	Value must be '20' Employee.
2010CA	REF	Property and Casualty Claim Number	Enter the claim number if known. If not known, then enter the default value of “unknown”.
2010CA	REF	Property and Casualty Patient Identifier	Required.
2010CA	REF01	Reference Identification Qualifier	Value must be ‘SY’ (Social Security Number)
2010CA	REF02	Reference Identification	Value must be the patient’s Social Security Number. When applicable, utilize ‘999999999’ as a default value where the social security number is not known.
2300	CLM11	Related Causes Information	One of the occurrences in CLM11 must have a value of ‘EM’ -- Employment Related.
2300	DTP	Date—Accident	Required when the condition reported is for an occupational accident/injury.
2300	DTP	Date—Disability Dates	Do not use Segment. Leave blank.
2300	DTP	Date—Property And Casualty Date Of First Contact	Do not use Segment . Not Applicable to LA regulations.
2300	PWK	Claim Supplemental Information	Refer to the companion guide for instruction regarding Documentation/Medical Attachment Requirements.
2300	PWK01	Report Type Code	Use appropriate 005010 Report Type Code.
2300	PWK06	Attachment Control Number	Enter the Attachment Control Number Example PWK*OB*BM***AC*DMN 0012~
2300	K3	File Information	State Jurisdictional Code is expected here.
2300	K301	2300	Jurisdiction State Code (State of Compliance Code) Required when the provider knows the state of Jurisdiction is different than the billing provider’s state (2010AA/N4/N402). Enter the state code qualifier ‘LU’ followed by the state code. For example, ‘LULA’ indicates the medical bill is being submitted under Louisiana medical billing requirements.

ASC X12N/005010X222A1			
Loop	Segment	Description	Louisiana Companion Guide Workers’ Compensation Comments or Instructions
1000A	PER	Submitter EDI Contact Information	Communication Number Qualifier must be ‘TE’—Telephone Number
2000B	SBR	Subscriber Information	In workers' compensation, the Subscriber is the Employer.
2000B	SBR04	Name	In workers’ compensation, the group name is the employer of the patient/employee.
2000B	SBR09	Claim Filing Indicator Code	Value must be 'WC' for workers’ compensation.
2010BA		Subscriber Name	In workers' compensation, the Subscriber is the Employer.
2010BA	NM102	Entity Type Qualifier	Value must be '2' non-person.
2010BA	NM103	Name Last or Organization Name	Value must be the name of the Employer.
2010BA	REF	Property And Casualty Claim Number	Enter the claim number if known, If not known, then enter the default value of “unknown”.

ASC X12N/005010X222A1			
Loop	Segment	Description	Louisiana Companion Guide Workers' Compensation Comments or Instructions
	HI	Condition Information	For workers' compensation purposes, the National Uniform Billing Committee and the National Uniform Claims Committee has approved the following condition code (W2) for resubmission of a duplicate of the original bill. <ul style="list-style-type: none"> <li>W2—Duplicate of the original bill</li> </ul> Note: Do not use condition codes when submitting revised or corrected bills.

D. Companion Guide ASC X12N/005010X223A2 Health Care Claim: Institutional (837)

1. Introduction and Overview. The information contained in this companion guide has been created for use in conjunction with the ASC X12N/005010X223A2—health care claim: institutional (837) technical report type 3. It is not a replacement for the ASC X12N/005010X223A2—health care claim: institutional (837) technical report type 3, but rather is an additional source of information. This companion guide is not, nor was it ever intended to be, a comprehensive guide to the electronic transaction requirements for each of the Jurisdictions. The companion guide is intended to be used by Jurisdictions to develop and publish companion guides tailored to their regulatory environment that consistently apply the syntactical requirements of the ASC X12 type 3 technical reports. The ASC X12N/005010X223A2—health care claim: institutional (837) technical report type 3 is available through the Accredited Standards Committee (ASC) X12, <http://store.x12.org>.

2. Purpose, Applicability and Expected Implementation Date. The purpose of electronic billing (LAC 40:I.Chapter 3) is to provide a framework for electronic billing, processing, and payment of medical services and products provided to an injured employee and data reporting subject to R.S. 23:1203.2, mandated for insurance carriers, beginning July 1, 2013 for electronic submissions.

3. Trading Partner Agreements. The components of trading partner agreements that define other transaction parameters beyond the ones described in this companion guide (such as transmission parameters) remain the same; this companion guide is not intended to replace any of those components. The data elements transmitted as part of a trading partner agreement must, at a minimum, contain all the same required data elements found within the ASC X12 type 3 technical reports and the jurisdiction-specific companion guide. The workers' compensation field value designations as defined in the jurisdiction-specific companion guide must remain the same as part of any trading partner agreement.

4. Workers' Compensation Health Care Claim: Institutional Instructions. Instructions for Louisiana specific

requirements are also provided in Louisiana Workers' Compensation requirements. The following table identifies the application/instructions for Louisiana Workers' Compensation that need clarification beyond the ASC X12 type 3 technical reports.

ASC X12N/005010X223A2			
Loop	Segment	Description	Louisiana Companion Guide Workers' Compensation Comments or Instructions
1000A	PER	Submitter EDI Contact Information	Communication Number Qualifier must be 'TE'—Telephone Number
2000B	SBR	Subscriber Information	In workers' compensation, the Subscriber is the Employer.
2000B	SBR04	Name	In workers' compensation, the group name is the employer of the patient/employee.
2000B	SBR09	Claim Filing Indicator Code	Value must be 'WC' for workers' compensation.
2010BA		Subscriber Name	In workers' compensation, the Subscriber is the Employer.
2010BA	NM102	Entity Type Qualifier	Value must be '2' non-person.
2010BA	NM103	Name Last or Organization Name	Value must be the name of the Employer.
2010BA	REF	Property and Casualty Claim Number	Enter the claim number if known. If not known, then enter the default value of "unknown".
2000C	PAT01	Individual Relationship Code	Value must be '20' Employee.
2010CA	REF02	Property Casualty Claim Number	Enter the claim number if known. If not known, then enter the default value of "unknown".
2010CA	REF	Property and Casualty Patient Identifier	Required.
2010CA	REF01	Reference Identification Qualifier	Value must be 'SY'. (Social Security Number)
2010CA	REF02	Reference Identification	Value must be the patient's Social Security Number.
2300	PWK	Claim Supplemental Information	Refer to the Jurisdiction companion guide for instruction regarding Documentation/Medical Attachment Requirements.
2300	PWK01	Report Type Code	Use appropriate 005010 Report Type Code.
2300	PWK06	Attachment Control Number	Enter the Attachment Control Number Example: PWK*OB*BM***AC*DMN0012~
2300	K3	File Information	State Jurisdictional Code is expected here.
2300	K301	Fixed Format Information	Required when the provider knows the state of Jurisdiction is different than the billing provider's state (2010AA/N4/N402). Enter the state code qualifier 'LU' followed by the state code. For example, 'LULA' indicates the medical bill is being submitted under Louisiana medical billing requirements.

LABOR AND EMPLOYMENT

ASC X12N/005010X223A2			
Loop	Segment	Description	Louisiana Companion Guide Workers' Compensation Comments or Instructions
2300	HI01	Occurrence Information	At least one Occurrence Code must be entered with value of '04'—Accident/Employment Related or '11'—illness. The Occurrence Date must be the Date of Occupational Injury or Illness.
2300	HI	Condition Information	For workers' compensation purposes, the National Uniform Billing Committee and the National Uniform Claims Committee has approved the following condition code (W2) for resubmissions of a duplicate of the original bill. <ul style="list-style-type: none"> <li>• W2—Duplicate of the original bill</li> </ul> Note: Do not use condition codes when submitting revised or corrected bills.

E. Companion Guide ASC X12N/005010X224A2 Health Care Claim: Dental (837)

1. Introduction and Overview. The information contained in this companion guide has been created for use in conjunction with the ASC X12N/05010X224A2—health care claim: dental (837) technical report type 3. It is not a replacement for the ASC X12N/05010X224A2—health care claim: dental (837) technical report type 3, but rather is an additional source of information. This companion guide is not, nor was it ever intended to be, a comprehensive guide to the electronic transaction requirements for each of the Jurisdictions. The companion guide is intended to be used by Jurisdictions to develop and publish companion guides tailored to their regulatory environment that consistently apply the syntactical requirements of the ASC X12 type 3 technical reports. The ASC X12N/05010X224A2—health care claim: dental (837) technical report type 3 is available through the Accredited Standards Committee (ASC) X12, <http://store.x12.org>.

2. Purpose, Applicability and Expected Implementation Date. The purpose of electronic billing (LAC 40:I.Chapter 3) is to provide a framework for electronic billing, processing, and payment of medical services and products provided to an injured employee and data reporting subject to R.S. 23:1203.2, mandated for insurance carriers, beginning July 1, 2013 for electronic submissions.

3. Trading Partner Agreements. The components of trading partner agreements that define other transaction parameters beyond the ones described in this companion guide (such as transmission parameters) remain the same; this companion guide is not intended to replace any of those components. The data elements transmitted as part of a trading partner agreement must, at a minimum, contain all the same required data elements found within the ASC X12 type 3 technical reports and the jurisdiction-specific companion guide. The workers' compensation field value

designations as defined in the Jurisdiction-specific companion guide must remain the same as part of any trading partner agreement.

4. Workers' Compensation Health Care Claim: Dental Instructions. Instructions for Louisiana specific requirements are also provided in Louisiana Workers' Compensation requirements. The following table identifies the application/instructions for Louisiana workers' compensation that need clarification beyond the ASC X12 type 3 technical reports.

Loop	Segment	Description	Louisiana Companion Guide Workers' Compensation Comments or Instructions
1000A	PER	Submitter EDI Contact Information	Communication Number Qualifier must be 'TE'—Telephone Number
2000B	SBR	Subscriber Information	In workers' compensation, the Subscriber is the Employer.
2000B	SBR04	Name	In workers' compensation, the group name is the employer of the patient/employee.
2000B	SBR09	Claim Filing Indicator Code	Value must be 'WC' for workers' compensation.
2010BA		Subscriber Name	In workers' compensation, the Subscriber is the Employer.
2010BA	NM102	Entity Type Qualifier	Value must be '2' non-person.
2010BA	NM103	Name Last Or Organization Name	Value must be the name of the Employer.
2010BA	REF	Property And Casualty Claim Number	Enter the claim number if known. If not known, then enter the default value of "unknown".
2000C	PAT01	Individual Relationship Code	Value must be '20' Employee.
2010CA	REF02	Property Casualty Claim Number	Enter the claim number if known. If not known, then enter the default value of "unknown".
2300	CLM11	Related Causes Information	One of the occurrences in CLM11 must have a value of 'EM' -- Employment Related.
2010CA	REF	Property And Casualty Patient Identifier	Required.
2010CA	REF01	Reference Identification Qualifier	Value must be 'SY'. (Social Security Number)
2010CA	REF02	Reference Identification	Value must be the patient's Social Security Number.
2300	DTP	Date—Accident	Required when the condition reported is for an occupational accident/injury.
2300	PWK	Claim Supplemental Information	Refer to the Jurisdiction companion guide for instruction regarding Documentation/Medical Attachment Requirements.
2300	PWK01	Report Type Code	Use appropriate 005010 Report Type Code.

Loop	Segment	Description	Louisiana Companion Guide Workers' Compensation Comments or Instructions
2300	PWK06	Attachment Control Number	Enter Attachment Control Number Example: PWK*OB*BM***AC*DM N0012~
2300	K3	File Information	State Jurisdictional Code is expected here.
2300	K301	Fixed Format Information	Jurisdiction State Code (State of Compliance Code) Required when the provider knows the state of Jurisdiction is different than the billing provider's state (2010AA/N4/N402). Enter the state code qualifier 'LU' followed by the state code. For example, 'LULA' indicates the medical bill is being submitted under Louisiana medical billing requirements.

F. Companion Guide NCPDP D.0 Pharmacy

1. Introduction and Overview. The information contained in this companion guide has been created for use in conjunction with the *NCPDP telecommunication standard implementation guide version D.0* for pharmacy claim transactions. It is not a replacement for the *NCPDP telecommunication standard implementation guide version D.0*, but rather is an additional source of information. Pharmacy transactions are processed both in real-time and via batch. Every transmission request has a transmission response. To address the appropriate process for responding to request transactions and reversal processing, users are directed to utilize the *NCPDP telecommunication standard implementation guide version D.0* and *Batch Standard Implementation Guide Version 1.2*. This companion guide is not, nor was it ever intended to be, a comprehensive guide to the electronic transaction requirements for each of the Jurisdictions. The companion guide is intended to be used by Jurisdictions to develop and publish companion guides tailored to their regulatory environment that consistently apply the syntactical requirements of the NCPDP Implementation Guide. The implementation guide for electronic pharmacy claims and responses is available through the National Council for Prescription Drug Programs (NCPDP) at <http://www.ncdp.org>.

2. Purpose, Applicability and Expected Implementation Date. The purpose of electronic billing (LAC40:ICchapter 3) is to provide a framework for electronic billing, processing, and payment of medical services and products provided to an injured employee and data reporting subject to R.S. 23:1203.2, mandated for insurance carriers, beginning July 1, 2013 for electronic submissions.

3. Trading Partner Agreements. The components of trading partner agreements that define other transaction parameters beyond the ones described in this companion guide (such as transmission parameters) remain the same; this companion guide is not intended to replace any of those

components. The data elements transmitted as part of a trading partner agreement must, at a minimum, contain all the same required data elements found within the NCPDP Implementation Guide and the Jurisdiction-specific companion guide. The workers' compensation field value designations as defined in the Jurisdiction-specific companion guide must remain the same as part of any trading partner agreement. Where a payer has a separate contract with a Pharmacy Benefits Manager (PBM), the data elements exchanged between the payer and PBM may be in a mutually agreed upon format.

4. Workers' Compensation NCPDP Pharmacy Claim Instructions. Instructions for Louisiana specific requirements are also provided in Louisiana Workers' Compensation Requirements. The following table identifies the application/instructions for Louisiana workers' compensation that need clarification beyond the NCPDP telecommunication standard implementation guide version D.0.

Segment	Field	Description	Louisiana Companion Guide Workers' Compensation Comments or Instructions
Insurance	3Ø2-C2	Cardholder ID	If the Cardholder ID is not available or not applicable, the value must be 'NA'.
Claim	415-DF	Number of Refills Authorized	This data element is optional.
Pricing	426-DQ	Usual and Customary Charge	This data element is optional.
Pharmacy Provider	465-EY	Provider ID Qualifier	This data element is required. The value must be '05' – NPI Number.
Prescriber	466-EZ	Prescriber ID Qualifier	This data element is required. The value must be '01' – NPI Number, however, if prescriber NPI is not available, enter applicable prescriber ID qualifier.
Workers' Compensation			The Workers' Compensation Segment is required for workers' compensation claims
Workers' Compensation	435-DZ	Claim/Reference ID	Enter the claim number if known. If not known, then enter the default value of "unknown".
Clinical			This data element is optional.
Additional Documentation			The Additional Documentation segment can be utilized for any additional information that does not have a required field above.

G. Companion Guide ASC X12N/005010X221A1 Health Care Claim Payment/Advice (835)

1. Introduction and Overview. The information contained in this companion guide has been created for use in conjunction with the *ASC X12N/005010X221A1 Health Care Claim Payment Advice (835) Technical Report Type 3*. It is not a replacement for the *ASC X12N/005010X221A1 Health Care Claim Payment Advice (835) Technical Report*

*Type 3*, but rather is an additional source of information. This companion guide is not, nor was it ever intended to be, a comprehensive guide to the electronic transaction requirements for each of the Jurisdictions. The companion guide is intended to be used by Jurisdictions to develop and publish companion guides tailored to their regulatory environment that consistently apply the syntactical requirements of the ASC X12 type 3 technical reports. The ASC X12N/005010X221A1—health care claim payment advice (835) technical report type 3 is available through the Accredited Standards Committee (ASC) X12, <http://store.x12.org>. The NCPDP ASC X12N 835 (005010X221)—pharmacy remittance advice template, is available at [http://www.ncdp.org/public\\_documents.asp](http://www.ncdp.org/public_documents.asp).

2. Purpose, Applicability and Expected Implementation Date. The purpose of electronic billing (LAC40:ICchapter 3) is to provide a framework for electronic billing, processing, and payment of medical services and products provided to an injured employee and data reporting subject to R.S. 23:1203.2, mandated for insurance carriers, beginning July 1, 2013 for electronic submissions. Electronic remittance notification is not mandated at this time and may be used upon mutual agreement of the parties.

3. Trading Partner Agreements. The components of trading partner agreements that define other transaction parameters beyond the ones described in this companion guide (such as transmission parameters) remain the same; this companion guide is not intended to replace any of those components. The data elements transmitted as part of a trading partner agreement must at a minimum contain all the same required data elements found within the ASC X12 type 3 technical reports and the jurisdiction-specific companion guide. The workers' compensation field value designations as defined in the Jurisdiction-specific companion guide must remain the same as part of any trading partner agreement. Trading partner agreements pertaining to claims adjustment group codes and claim adjustment reason code/remittance advice remark code combinations must follow the current ASC X12N—technical report type 2 (TR2) code value usage in health care claim payments and subsequent claims reference model, that identifies usage standards when providing payment, reduction, or denial information. The TR2 is available at <http://store.x12.org>.

4. Claim Adjustment Group Codes. The 005010X221A1 transaction requires the use of claim adjustment group codes. The most current valid codes must be used as appropriate for workers' compensation. The claim adjustment group code represents the general category of payment, reduction, or denial. For example, the group code 'CO' (contractual obligation) might be used in conjunction with a claim adjustment reason code for a network contract reduction. The claim adjustment group code transmitted in the 005010X221A1 transaction is the same code that is transmitted in the IAIABC 837 medical state reporting EDI reporting format. Louisiana Workforce Commission, Office of Workers Compensation accepts claim adjustment group codes that were valid on the date the payer paid or denied a bill.

5. Claim Adjustment Reason Codes. The 005010X221A1 transaction requires the use of claim adjustment reason codes (CARC) codes as the electronic means of providing specific payment, reduction, or denial information. As a result, use of the 005010X221A1 transaction eliminates the use of proprietary reduction codes, jurisdiction-specific claim adjustment reason codes, and free form text used on paper explanation of review (EOR) forms. Claim adjustment reason codes are available through Washington Publishing Company at [www.wpc-edi.com/codes](http://www.wpc-edi.com/codes). The ASC X12N—technical report type 2 (TR2) code value usage in health care claim payments and subsequent claims reference model is the encyclopedia of claim adjustment group codes, claim adjustment reason code (CARC) and remittance advice remark code (RARC) combinations. The most current TR2 specified CARC and/or CARC RARC code combinations are to be used when providing payment, reduction, or denial information. The TR2 is available at <http://store.x12.org>. There is a great amount of variability in the mapping and combinations of codes used in the industry today. This results in different interpretations by the providers for each payer. The TR2 defines CARC/RARC combinations which will provide a concrete and predictable message allowing the providers to set up rules to automate actions based upon the combinations of codes. Consistent use of these codes across all payers will result in significant administrative simplification in the workers' compensation industry. Every three months codes are added, modified or deleted through the ASC X12 external code committee process. These changes are maintained by ASC X12 and are updated in the TR2. If it is determined that a code, or CARC/RARC combination, needs to be added, modified or deleted, contact the IAIABC EDI Medical Committee to submit your request at [www.IAIABC.org/](http://www.IAIABC.org/).

6. Remittance Advice Remark Codes. The 005010X221A1 transaction supports the use of remittance advice remark codes to provide supplemental explanations for a payment, reduction, or denial already described by a claim adjustment reason code. NCPDP reject codes are allowed for NCPDP transactions. Payers must use the remittance remark codes to provide additional information to the health care provider regarding why a bill was adjusted or denied. The use of the 005010X221A1 transaction eliminates the use of proprietary reduction codes and free form text used on paper explanation of review (EOR) forms. Remittance advice remark codes are not associated with a group or reason code in the same manner that a claim adjustment reason code is associated with a group code. Currently, the 005010X221A1 is an optional transaction to be used upon mutual agreement by the payer and healthcare provider. Remittance advice remark codes are available through Washington Publishing Company at <http://www.wpc-edi.com/codes>.

7. Product/Service ID Qualifier. The product/service identification number transmitted in the inbound electronic billing format is returned in the 005010X221A1 transaction SVC service payment information segment with the appropriate qualifier.

8. Workers' Compensation Health Care Claim Payment/Advice Instructions. Instructions for Louisiana-specific requirements are also provided in Louisiana workers' compensation requirements. The following table identifies the application/instructions for Louisiana workers' compensation requirements that need clarification beyond the ASC X12 type 3 technical reports. Currently, the 005010X221A1 is an optional transaction to be used upon mutual agreement by the payer and healthcare provider.

ASC X12N/005010X221A1				
Loop	Segment or Element	Value	Description	Louisiana Companion Guide Workers' Compensation Comments or Instructions
1000A	PER		Payer Technical Contact Information	
	PER03	TE	Communication Number Qualifier	Value must be 'TE' Telephone Number
	PER04		Communication Number	Value must be the Telephone Number of the submitter.
2100	CLP		Claim Level Data	
	CLP06	WC	Claim Filing Indicator Code	Value must be "WC"—Workers' Compensation
	CLP07		Payer Claim Control Number	The payer-assigned claim control number for workers' compensation use is the bill control number.

H. Companion Guide ASC X12N/005010X210 Additional Information to Support a Health Care Claim or Encounter (275)

1. Introduction and Overview. The information contained in this companion guide has been created for use in conjunction with the ASC X12N/005010X210—additional information to support a health care claim or encounter (275) technical report type 3. It is not a replacement for the ASC X12N/005010X210—additional information to support a health care claim or encounter (275) technical report type 3, but rather is an additional source of information. This companion guide is not, nor was it ever intended to be, a comprehensive guide to the electronic transaction requirements for each of the jurisdictions. The companion guide is intended to be used by jurisdictions to develop and publish companion guides tailored to their regulatory environment that consistently apply the syntactical requirements of the ASC X12N type 3 technical reports. The ASC X12N/005010X210—additional information to support a health care claim or encounter (275) technical report type 3 is available through the Accredited Standards Committee (ASC) X12, <http://store.x12.org>.

2. Purpose, Applicability, and Expected Implementation Date. The purpose of electronic billing (LAC 40:I.Chapter 3) is to provide a framework for electronic billing, processing, and payment of medical services and products provided to an injured employee and

data reporting subject to R.S. 23:1203.2, mandated for insurance carriers, beginning July 1, 2013 for electronic submissions.

3. Method of Transmission. The 005010X210 transaction is the prescribed standard electronic format for submitting electronic documentation. Health care providers, health care facilities, or third party biller/assignees and payers may agree to exchange documentation in other non-prescribed electronic formats (such as uploading to a web-based system) by mutual agreement. If trading partners mutually agree to use non-prescribed formats for the documentation they exchange, they must include all components required to identify the information associated with the documentation. Health care providers, health care facilities, or third party biller/assignees and payers may also elect to submit documentation associated with electronic bill transactions through facsimile (fax) or electronic mail (email) in accordance electronic billing (LAC 40:I.Chapter 3). Health care providers, health care facilities, or third party biller/assignees and payers must be able to electronically exchange medical documentation that is required to be submitted with the bill based on the regulatory requirements found in electronic billing (LAC 40:I.Chapter 3).

4. Documentation Requirements. Medical documentation includes, but is not limited to, medical reports and records, such as evaluation reports, narrative reports, assessment reports, progress report/notes, clinical notes, hospital records, and diagnostic test results. Documentation requirements for Louisiana workers' compensation billing are defined in electronic billing (LAC 40:I.Chapter 3).

I. Companion Guide Acknowledgments

1. There are several different acknowledgments that a clearinghouse and/or payer may use to respond to the receipt of a bill. The purpose of these acknowledgments is to provide feedback on the following:

- a. Basic file structure and the trading partner information from the interchange header.
- b. Detailed structure and syntax of the actual bill data as specified by the X12 standard.
- c. The content of the bill against the jurisdictional complete bill rules.
- d. Any delays caused by claim number indexing/validation.
- e. Any delays caused by attachment matching.
- f. The outcome of the final adjudication, including reassociation to any financial transaction.

2. Bill Acknowledgment Flow and Timing Diagrams. The process chart below illustrates how a receiver validates and processes an incoming 005010X222A1, 005010X223A2, or 005010X224A2 transaction. The diagram shows the basic acknowledgments that the receiver generates, including acknowledgments for validation and final adjudication for those bills that pass validation.



LABOR AND EMPLOYMENT

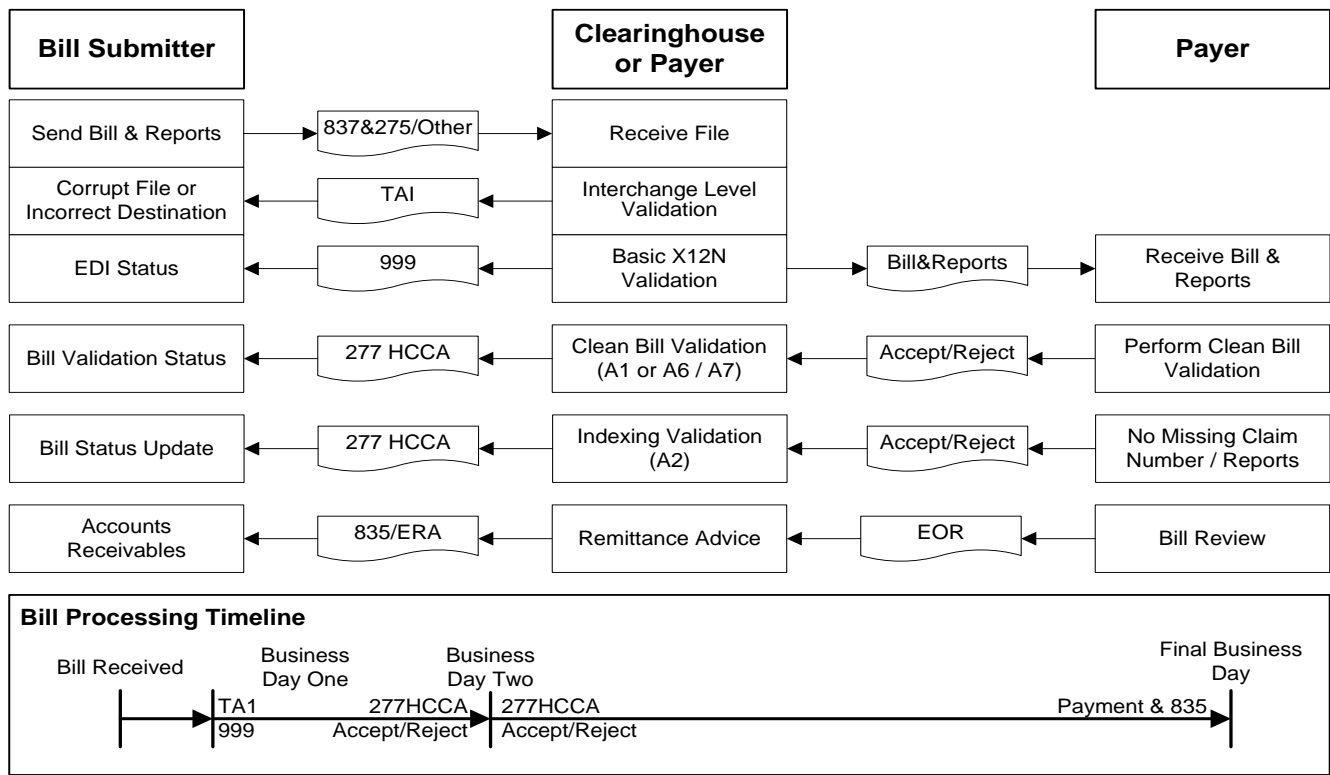

3. Process Steps

a. Interchange Level Validation. Basic file format and the trading partner information from the Interchange Header are validated. If the file is corrupt or is not the expected type, the file is rejected. If the trading partner information is invalid or unknown, the file is rejected. A TA1 (interchange acknowledgment) is returned to indicate the outcome of the validation. A rejected EDI file is not passed on to the next step.

b. Basic X12 Validation. A determination will be made as to whether the transaction set contains a valid 005010X222A1. A 005010X231 (functional acknowledgment) will be returned to the submitter. The 005010X231 contains “accept” or “reject” information. If the file contains syntactical errors, the locations of the errors are reported. Bills that are part of a rejected transaction set are not passed on to the next step.

c. Clean Bill Validation. The jurisdictional and payer specific edits are run against each bill within the transaction set. The receiver returns a 005010X214 (health care claim acknowledgment) to the submitter to acknowledge that the bill was accepted or rejected. Bills that are rejected are not passed on to the next step.

d. Clean Bill-Missing Claim Number and/or Missing Required Report. Refer to section 9.2, clean claim-missing claim number pre-adjudication hold (pending) status and section 9.3, clean claim-missing report pre-adjudication hold (pending) status regarding bill acknowledgment flow and timeline diagrams.

e. Bill Review. The bills that pass through bill review and any post-bill review approval process will be

reported in the 005010X221A1 (remittance payment/advice). The 005010X221A1 contains the adjudication information from each bill, as well as any paper check or EFT payment information. Currently, the 005010X221A1 is an optional transaction to be used upon mutual agreement by the payer and healthcare provider.

4. Clean Bill-Missing Claim Number Pre-Adjudication Hold (Pending) Status

a. One of the processing steps that a bill goes through prior to adjudication is verification that the bill concerns an actual employment-related condition that has been reported to the employer and subsequently reported to the claims administrator. This process, usually called “claim indexing/validation” can cause a delay in the processing of the bill. Once the validation process is complete, the claim administrator assigns a claim number to the injured worker’s claim. This claim number is necessary for the proper processing of any bills associated with the claim. Until the claim number is provided to the bill submitter, it cannot be included on the 005010X222A1, 005010X223A2, and 005010X224A2 submission to the payer. In order to prevent medical bills from being rejected due to lack of a claim number, a pre-adjudication hold (pending) period of up to five business days is mandated to enable the payer to attempt to match the bill to an existing claim in its system. If the bill cannot be matched within the five business days, the bill may be rejected as incomplete. If the payer is able to match the bill to an existing claim, it must attach the claim number to the transaction and continue the adjudication process. The payer then provides the claim number to the bill submitter using the 005010X214 for use in future billing. The 005010X214 is also used to inform the bill submitter of the delay and the ultimate resolution of the issue. Due to the pre-



adjudication hold (pend) status, a payer may send one STC segment with up to three claim status composites (STC01, STC10, and STC11) in the 005010X214. When a clean claim has a missing claim number and a missing report, the one STC segment in the 005010X214 would have the following three claim status composites: STC01, STC10, and STC11.

i. An example: STC\*A1:21\*20090830\*WQ\*70\*\*\*\*\*A1:629\*A1:294~.

b. When a clean bill is only missing a claim number or missing a report, the one STC segment in the

005010X214 would have the following two claim status composites: STC01 and STC10.

i. An example: STC\*A1:21\*20090830\*WQ\*70\*\*\*\*\*A1:629~.

c. A bill submitter could potentially receive two 005010X214 transactions as a result of the pre-adjudication hold (pend) status.

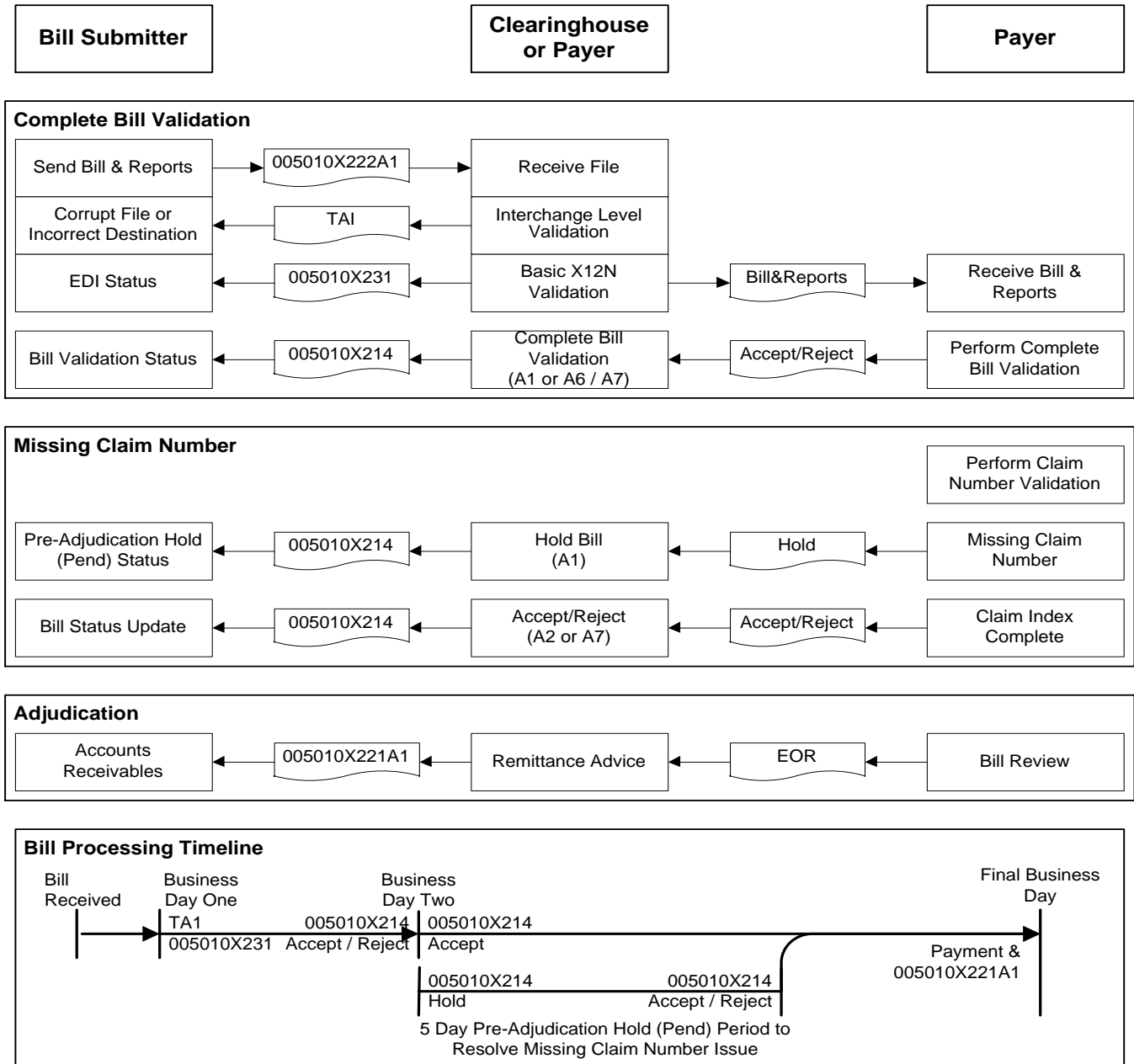

5. Missing Claim Number 005010X214 Acknowledgment Process Steps. When the 005010X222A1, 005010X223A2, or 005010X224A2 transaction has passed the clean bill validation process and loop 2010 CA REF02

indicates that the workers' compensation claim number is "unknown," the payer will need to respond with the appropriate 005010X214.

LABOR AND EMPLOYMENT

Claim Number Validation Status	005010X214
Clean Bill— Missing Claim Number	<p>If the payer needs to pend an otherwise clean bill due to a missing claim number, it must use the following Claim Status Category Code and Claim Status Code:</p> <p>STC01-1 = A1 (The claim/encounter has been received. This does not mean that the claim has been accepted for adjudication.)</p> <p>STC01-2 = 21 (Missing or Invalid Information)</p> <p>AND</p> <p>STC10-1 = A1 (The claim/encounter has been received. This does not mean that the claim has been accepted for adjudication.)</p> <p>STC10-2 = 629 (Property Casualty Claim Number)</p> <p>Example: STC*A1:21*20090830*WQ*70*****A1:629~</p>
Claim Was Found	<p>Once the Claim Indexing/Validation process has been completed and there is a bill/claim number match, then use the following Claim Status Category Code with the appropriate Claim Status Code:</p> <p>STC01-1 = A2 Acknowledgment/Acceptance into adjudication system. The claim/encounter has been accepted into the adjudication system.</p> <p>STC01-2 = 20 Accepted for processing</p> <p>Payer Claim Control Number: Use Loop 2200D REF segment "Payer Claim Control Number with qualifier 1K Identification Number to return the workers' compensation claim number and or the payer bill control number in the REF02:</p> <p>a. Always preface the workers' compensation claim number with the two digit qualifier "Y4" followed by the property casualty claim number. Example: Y412345678</p> <p>b. If there are two numbers (payer claim control number and the workers' compensation claim number) returned in the REF02, then use a blank space to separate the numbers.</p> <ul style="list-style-type: none"> <li>- The first number will be the payer claim control number assigned by the payer (bill control number).</li> <li>- The second number will be the workers' compensation property and casualty claim number</li> </ul>

Claim Number Validation Status	005010X214
	<p>assigned by the payer with a "Y4" qualifier followed by the claim number. - Example: REF*1K*3456832 Y43333445556</p>
No Claim Found	<p>After the Claim Indexing/ Validation process has been completed and there is no bill/ claim number match, use the following Claim Status Category Code with the appropriate Claim Status Code:</p> <p>STC01-1 = A6 Acknowledgment/Rejected for Missing Information. The claim/encounter is missing the information specified in the Status details and has been rejected.</p> <p>STC01-2 = 629 Property Casualty Claim Number (No Bill/Claim Number Match)</p>

6. Clean Bill-Missing Report Pre-Adjudication Hold (Pending) Status. One of the processing steps that a bill goes through prior to adjudication is verification that all required documentation has been provided. The bill submitter can send the reports using the 005010X210 or other mechanisms such as fax or e-mail. In order to prevent medical bill rejections because required documentation was sent separately from the bill itself, a pre-adjudication hold (pending) period of up to five business days is mandated to enable the payer to receive and match the bill to the documentation. If the bill cannot be matched within the five business days, or if the supporting documentation is not received, the bill may be rejected as incomplete. If the payer is able to match the bill to the documentation within the five business day hold period, it continues the adjudication process. The 005010X213 is used to inform the bill submitter of the delay and the ultimate resolution of the issue.

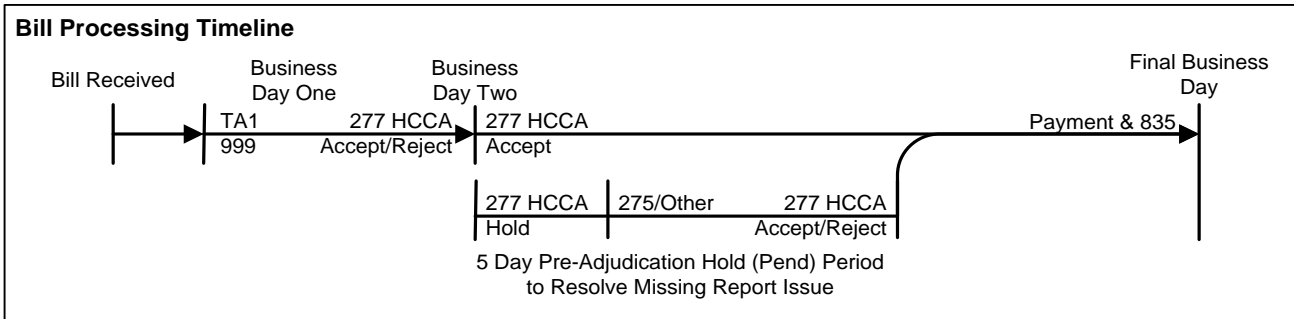
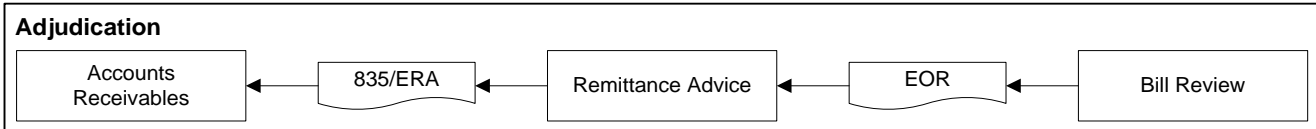
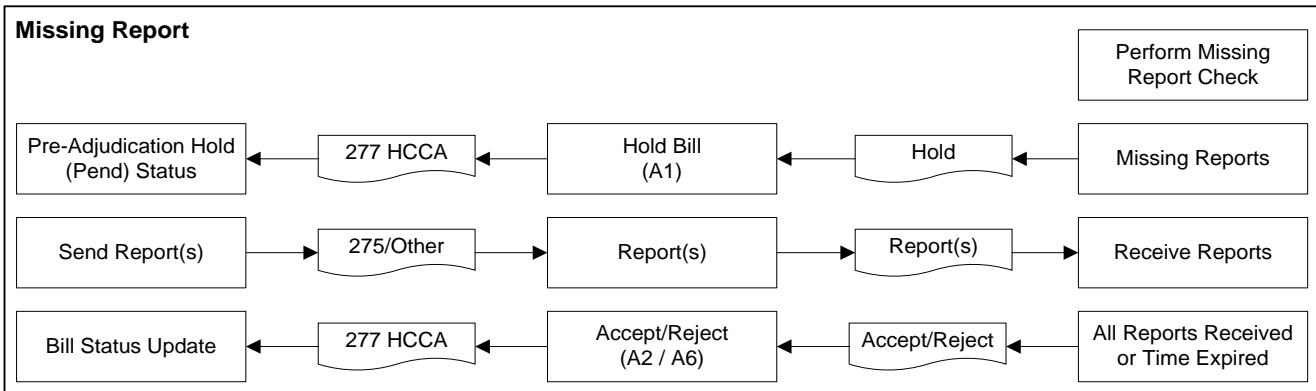
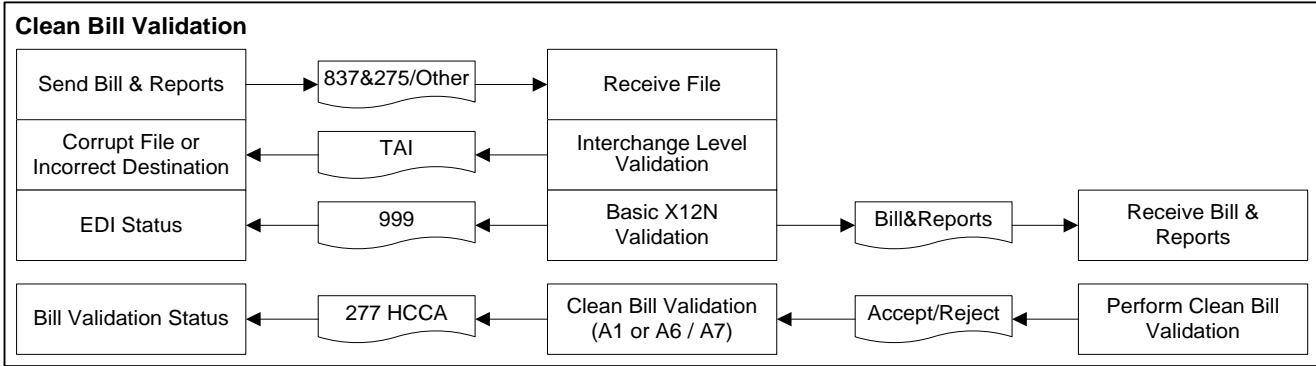

7. Missing Report—277 Health Care Claim Acknowledgment Process Steps. When a bill submitter sends an 837 that requires an attachment and loop 2300 PWK Segment indicates that a report will be following, the payer will need to respond with the appropriate 277 HCCA response(s) as applicable.

Bill Status Findings	277 HCCA Acknowledgment Options
Clean Bill—Missing Report	When a clean bill is missing a required report, the payer needs to place the bill in a pre-adjudication hold (pending) status during the specified waiting time period and return the following Claim Status Category Code and Claim

Bill Status Findings	277 HCCA Acknowledgment Options
	Status Code: STC01-1 = A1 The claim/encounter has been received. This does not mean that the claim has been accepted for adjudication. STC01-2 = 21 (Missing or Invalid Information) AND STC10-1 = A1 The claim/encounter has been received. This does not mean that the claim has been accepted for adjudication. STC10-2 = Use the appropriate 277 Claim Status Code for missing report type. Example: Claim Status Code 294 Supporting documentation

Bill Status Findings	277 HCCA Acknowledgment Options
	Example STC*A1:21*20090830*WQ*70*****A1:294-:
Report Received within the 5 day pre-adjudication hold (pending) period	Use the following Claim Status Category Code with the appropriate Claim Status Code: STC01-1= A2 Acknowledgment/Acceptance into adjudication system. The claim/encounter has been accepted into the adjudication system. STC01-2=20 Accepted for processing
No Report Received within the 5 day pre-adjudication hold (pending) period	Use the following Claim Status Category Code and Claim Status Code. STC01-1= A6 Acknowledgment/Rejected for Missing Information. The claim/encounter is missing the information specified in the Status details and has been rejected. STC01-2=294 Supporting documentation

8. Transmission Responses

a. Acknowledgments. The ASC X12 transaction sets include a variety of acknowledgments to inform the sender about the outcome of transaction processing. Acknowledgments are designed to provide information regarding whether or not a transmission can be processed, based on structural, functional, and/or application level requirements or edits. In other words, the acknowledgments inform the sender regarding whether or not the medical bill can be processed or if the transaction contains all the required data elements. Under electronic billing (LAC 40:I.Chapter 3) payers must return one of the following acknowledgments, as appropriate, according to the bill acknowledgment flow and timing diagrams found in section 9.1:

- i. TA1—implementation acknowledgment;
- ii. 005010X231—implementation acknowledgment (999);
- iii. 005010X214—health care claim acknowledgment (277);
- iii. detailed information regarding the content and use of the various acknowledgments can be found in the applicable ASC X12N type 3 technical reports (implementation guides);

b. 005010X213—request for additional information. The 005010X213, or request for additional information, is used to request missing required reports from the submitter. The following are the STC01 values:

- i. claim was pending; additional documentation required:
  - (a). STC01-1=R4 (pending/request for additional supporting documentation);
  - (b). STC01-2=the LOINC code indicating the required documentation;
- ii. additional information regarding this transaction set may be found in the applicable ASC X12N type 3 technical reports (implementation guides);

c. 005010X221A1—health care claim payment/advice. Within 30 calendar days of receipt of a complete electronic medical bill, the claims administrator is required to send the health care provider the 005010X221A1, if mutually agreed upon pursuant to LAC 40:I.Chapter 3, or health care claim payment/advice or other form of paper EOR. This transaction set informs the health care provider about the payment action the claims administrator has taken. Additional information regarding this transaction set may be found in chapter 7 of this companion guide and the applicable ASC X12N type 3 technical reports implementation guides;

d. 005010X212—health care claim status request and response. The 005010X212 transaction set is used in the group health industry to inquire about the current status of a specified healthcare bill or bills. The 276 transaction set identifier code is used for the inquiry and the 277 transaction set identifier code is used for the reply. It is possible to use these transaction sets unchanged in workers’ compensation bill processing. Additional information regarding this transaction set may be found in the applicable ASC X12N type 3 technical reports implementation guides.

J. Appendix A—Glossary of Terms

ADA—American Dental Association.

ADA-2006—American Dental Association (ADA) standard paper billing form.

AMA—American Medical Association.

ANSI—American National Standards Institute, a private, non-profit organization that administers and coordinates the U.S. voluntary standardization and conformity assessment system.

ASC X12 275—a standard transaction developed by ASC X12 to transmit various types of patient information.

ASC X12 835—a standard transaction developed by ASC X12 to transmit various types of health care claim payment/advice information.

ASC X12 837—a standard transaction developed by ASC X12 to transmit various types of health care claim information.

Acknowledgment—electronic notification to original sender of an electronic transmission that the transactions within the transmission were accepted or rejected.

CDT—current dental terminology, coding system used to bill dental services.

CMS—Centers for Medicare and Medicaid Services, the federal agency that administers these programs.

CMS-1500—the paper professional billing form formerly referred to as an HCFA or HCFA-1500.

CPT—Current Procedural Terminology, the coding system created and copyrighted by the American Medical Association that is used to bill professional services.

*Clearinghouse*—a public or private entity, including a billing service, repricing company, community health management information system or community health information system, and value-added networks and switches, that is an agent of either the payer or the provider and that may perform the following functions:

a. processes or facilitates the processing of medical billing information received from a client in a nonstandard format or containing nonstandard data content into standard data elements or a standard transaction for further processing of a bill related transaction; or

b. receives a standard transaction from another entity and processes or facilitates the processing of medical billing information into a nonstandard format or nonstandard data content for a client entity. An entity that processes information received in a nonstandard format or containing nonstandard data content into a standard transaction, or that receives a standard transaction and processes that information into a nonstandard transaction.

*Code Sets*—tables or lists of codes used for specific purposes. National standard formats may use *code sets* developed by the standard setting organization (i.e. X12 provider type qualifiers) or by other organizations (i.e. HCPCS codes).

*Complete Bill*—a complete electronic medical bill and its supporting transmissions must:

a. be submitted in the correct billing format, with the correct billing code sets;

b. be transmitted in compliance with all necessary format requirements;

c. include in legible text all medical reports and records, including, but not limited to, evaluation reports, narrative reports, assessment reports, progress report/notes, clinical notes, hospital records and diagnostic test results that are expressly required by law or can reasonably be expected by the payer or its agent under the jurisdiction's law;

d. include any other jurisdictional requirements found in its regulations or companion guide.

*DEA*—Drug Enforcement Administration.

*DEA Number*—prescriber DEA identifier used for pharmacy billing.

*Detail Acknowledgment*—electronic notification to original sender that its electronic transmission or the transactions within the transmission were accepted or rejected.

*EFT*—electronic funds transfer.

*EOB/EOR*—explanation of benefits (EOB) or explanation of review (EOR) is the paper form sent by the payer to the health care provider, health care facility, or third party biller/assignee to explain payment or denial of a medical bill. The *EOB/EOR* might also be used to request recoupment of an overpayment or to acknowledge receipt of a refund.

*Electronic Bill*—a bill submitted electronically from the health care provider, health care facility, or third-party biller/assignee to the payer.

*Electronic Format*—the specifications defining the layout of data in an electronic transmission.

*Electronic Record*—a group of related data elements. A record may represent a line item, a health care provider, health care facility, or third party biller/assignee, or an employer. One or more records may form a transaction.

*Electronic Transaction*—a set of information or data stored electronically in a defined format that has a distinct and different meaning as a set. An electronic transaction is made up of one or more electronic records.

*Electronic Transmission*—a collection of data stored in a defined electronic format. An electronic transmission may be a single electronic transaction or a set of transactions.

*Electronic Transmission*—transmission of information by facsimile, electronic mail, electronic data interchange, or any other similar method that does not include telephonic communication. For the purposes of the electronic billing rules, electronic transmission generally does not include facsimile or electronic mail.

*Functional Acknowledgment*—electronic notification to the original sender of an electronic transmission that the functional group within the transaction was accepted or rejected.

*HCPCS—Healthcare Common Procedure Coding System*, the HIPAA code set used to bill durable medical equipment, prosthetics, orthotics, supplies, and biologics (level II) as well as professional services (level I). Level I HCPCS codes are CPT codes

*HIPAA*—Health Insurance Portability and Accountability Act, federal legislation that includes provisions that mandate electronic billing in the Medicare system and establishes national standard electronic file formats and code sets.

*IAIABC*—International Association of Industrial Accident Boards and Commissions.

*IAIABC 837*—an implementation guide developed by the IAIABC based on the ASC X12 standard to transmit various types of health care medical bill and payment information from payers to jurisdictional workers' compensation agencies.

*ICD-9*—*International Classification of Diseases*, the code set administered by the World Health Organization used to identify diagnoses.

*MS-1450*—the paper hospital, institutional, or facility billing form, also referred to as a UB-04 or UB-92, formerly referred to as an HCFA-1450.

*NABP*—National Association of Boards of Pharmacy, the organization previously charged with administering pharmacy unique identification numbers. See *NCPDP*.

**NABP Number**—identification number assigned to an individual pharmacy, administered by NCPDP (other term: *NCPDP provider ID*).

**NCPDP**—National Council for Prescription Drug Programs, the organization administering pharmacy-unique identification numbers called NCPDP provider IDs.

**NCPDP Provider ID Number**—identification number assigned to an individual pharmacy, previously referred to as NABP number.

**NCPDP Telecommunication D.0**—HIPAA compliant national standard billing format for pharmacy services.

**NCPDP WC/PC UCF**—National Council for Prescription Drug Programs workers' compensation/property and casualty universal claim form, the pharmacy industry standard for pharmacy claims billing on paper forms.

**NDAS-National Dental Advisory Service**—glossary of dental benefit technology, medical terminology for TMJ and oral surgery billing, and common dental terms utilized for pricing.

**NDC—National Drug Code**, the code set used to identify medication dispensed by pharmacies.

**Payer**—the entity responsible, whether by law or contract, for the payment of the medical expenses incurred by a claimant as a result of a work related injury.

**Receiver**—the entity receiving/accepting an electronic transmission.

**Remittance**—*remittance* is used in the electronic environment to refer to reimbursement or denial of medical bills.

**Sender**—the entity submitting an electronic transmission.

**Trading Partner**—an entity that has entered into an agreement with another entity to exchange data electronically.

**UB-04**—universal billing form used for hospital billing. Replaced the UB-92 as the CMS-1450 billing form effective May 23, 2007.

**UB-92**—universal billing form used for hospital billing, also referred to as a CMS-1450 billing form. Discontinued use as of May 23, 2007.

**Version**—electronic formats may be modified in subsequent releases. Version naming conventions indicate the release or version of the standard being referenced. Naming conventions are administered by the standard setting organization. Some ASC X12 versions, for example, are 3050, 4010, and 4050.

**AUTHORITY NOTE:** Promulgated in accordance with R.S. 23:1310.1.

**HISTORICAL NOTE:** Promulgated by the Louisiana Workforce Commission, Office of Workers Compensation Administration, LR 39:331 (February 2013), Workforce Commission, Office of Workers Compensation, amended LR 40:375 (February 2014).

## §307. Billing Code Sets

A. Billing codes and modifier systems identified below are valid codes for these workers' compensation transactions, in addition to any code sets defined by the standards adopted in Section 305.

1. "CDT-4 Codes"—codes and nomenclature prescribed by the American Dental Association.

2. "CPT-4 Codes"—the procedural terminology and codes contained in the "Current Procedural Terminology, Fourth Edition," as published by the American Medical Association and as adopted in the appropriate fee schedule contained in Title 40 of the *Louisiana Administrative Code*.

3. "Diagnosis Related Group (DRG)"—the inpatient classification scheme used by CMS for hospital inpatient reimbursement. The DRG system classifies patients based on principal diagnosis, surgical procedure, age, presence of comorbidities and complications, and other pertinent data.

4. "HCPCS"—CMS' Healthcare Common Procedure Coding System, a coding system which describes products, supplies, procedures, and health professional services and which includes the American Medical Association's (AMA's) Physician "Current Procedural Terminology, Fourth Edition," (CPT-4) codes, alphanumeric codes, and related modifiers.

5. "ICD-9-CM Codes"—diagnosis and procedure codes in the International Classification of Diseases, Ninth Revision, Clinical Modification published by the United States Department of Health and Human Services.

6. "ICD-10-CM/PCS Codes"—diagnosis and procedure codes in the *International Classification of Diseases*, Tenth Edition, Clinical Modification/Procedure Coding System maintained and published by the United States Department of Health and Human Services.

7. "NDC"—National Drug Codes of the Food and Drug Administration.

8. "Physical Therapy"/"Occupational Therapy Codes: Codes specified in Title 40 of the LAC covering physical therapy and occupational therapy services.

9. "Revenue Codes"—the four digit coding system developed and maintained by the National Uniform Billing Committee for billing inpatient and outpatient hospital services, home health services, and hospice services.

10. "National Uniform Billing Committee codes"—code structure and instructions established for use by the National Uniform Billing Committee (NUBC), such as occurrence codes, condition codes, or prospective payment indicator codes. These are known as UB 04 Codes.

**AUTHORITY NOTE:** Promulgated in accordance with R.S. 23:1203.2.

**HISTORICAL NOTE:** Promulgated by the Louisiana Workforce Commission, Office of Workers' Compensation, LR 37:3544 (December 2011), amended LR 40:375 (February 2014).

### §309. Electronic Medical Billing, Reimbursement, and Documentation

#### A. Applicability

1. This Section outlines the exclusive process to exchange electronic medical bill and related payment processing data for professional, institutional/hospital, pharmacy, and dental services. This Section does not apply to requests for reconsideration or judicial appeals concerning any matter related to medical compensation or requests for informational copies of medical records.

2. Unless exempted from this process in accordance with Subsection B of this Section, insurance carriers or their agents shall:

a. accept electronic medical bills submitted in accordance with the adopted standards;

b. transmit acknowledgments and remittance advice in compliance with the adopted standards in response to electronically submitted medical bills; and

c. support methods to receive electronic documentation required for the adjudication of a bill, as described in Section 315 of this Chapter.

3. If a health care provider elects to utilize electronic medical bill submission, then the healthcare provider shall:

a. exchange medical bill data in accordance with the adopted standards;

b. submit medical bills as defined by Section 305.A of this Chapter, to insurance carriers that have established connectivity to the health care provider's system or clearinghouse;

c. submit required documentation in accordance with Subsection E of this Section; and

d. receive and process any acceptance or rejection acknowledgment from the insurance carrier.

4. Insurance carriers must be able to exchange electronic data by July 1, 2013 unless exempted from the process in accordance with Subsection B of this Section.

5. The insurance carrier's failure to comply with any requirements of this rule shall result in an administrative violation under LAC 40:109.A.

6. Health care providers who elect not to utilize electronic medical billing pursuant to Section 305.A.1 of this Chapter shall submit paper medical bills for payment pursuant to Title 40 of the *Louisiana Administrative Code*.

#### B. Waivers

1. An insurance carrier is waived from the requirement to receive medical bills electronically from health care providers if:

a. the insurance carrier processed 1200 or fewer medical bills for workers' compensation treatment or services in the previous calendar year;

b. written requests for waivers shall be submitted to the OWCA at least 90 days prior to the implementation date and renewed for each calendar year thereafter. Approved waivers shall be limited to the calendar year and must be requested in writing 90 days prior to each subsequent calendar year;

c. the OWCA may grant an exception on a case-by-case basis if the insurance carrier establishes that electronic billing will result in an unreasonable financial burden.

C. Notwithstanding any requirements in Section 305 of this Chapter, to be considered a complete electronic medical bill, the bill or supporting transmissions must:

1. include in legible text all medical reports and records, such as evaluation reports, narrative reports, assessment reports, progress report/notes, clinical notes, hospital records and diagnostic test results that are expressly required by Title 40 of the *Louisiana Administrative Code*;

2. identify the:

a. injured employee;

b. employer, if available;

c. insurance carrier, third party administrator, managed care organization or its agent;

d. health care provider;

e. medical service or product; and

f. any other requirements as presented in the electronic billing companion guide as promulgated by the OWCA.

3. Use current and valid codes and values as defined in the applicable formats defined in Sections 305 and 307 of this Chapter.

#### D. Acknowledgment

1. Interchange acknowledgment (TA1) notifies the sender of the receipt of, and certain structural defects associated with, an incoming transaction.

2. An Implementation Acknowledgment (ASCX12N999), or the most currently accepted transaction format, is an electronic notification to the sender of the file has been received and has been:

a. accepted as a complete and structurally correct file; or

b. rejected with a valid rejection code.

3. An ASC X12N 277 health care claim status response or acknowledgment transaction (detail acknowledgment) is an electronic notification to the sender of an electronic transaction (individual electronic bill) that the transaction has been received and has been:

a. accepted as a complete, correct submission; or

b. rejected with a valid rejection code.

## LABOR AND EMPLOYMENT

4. An insurance carrier must acknowledge receipt of an electronic medical bill by returning an implementation acknowledgment (ASCX12N999) within one business day of receipt of the electronic submission.

a. Notification of a rejected bill is transmitted using the appropriate acknowledgment when an electronic medical bill does not meet the definition of a complete electronic medical bill or does not meet the edits defined in the applicable implementation guide or guides.

b. A health care provider or its agent may not submit a duplicate electronic medical bill earlier than 60 business days from the date originally submitted if an insurance carrier has acknowledged acceptance of the original complete electronic medical bill. A health care provider or its agent may submit a corrected electronic medical bill to the insurance carrier after receiving notification of a rejection. The corrected medical bill is submitted as a new, original bill.

5. An insurance carrier must acknowledge receipt of an electronic medical bill by returning an ASC X12N 277 health care claim status response or acknowledgment transaction (detail acknowledgment) within two business days of receipt of the electronic submission.

a. Notification of a rejected bill is transmitted in an ASC X12N 277 response or acknowledgment when an electronic medical bill does not meet the definition of a complete electronic medical bill or does not meet the edits defined in the applicable implementation guide or guides.

b. A health care provider or its agent may not submit a duplicate electronic medical bill earlier than 60 days from the date originally submitted if an insurance carrier has acknowledged acceptance of the original complete electronic medical bill.

6. Acceptance of a complete medical bill is not an admission of liability by the insurance carrier. An insurance carrier may subsequently deny an accepted electronic medical bill if the employer or other responsible party named on the medical bill is not legally liable for its payment.

a. Any subsequent denial of a complete medical bill must occur within the timeframe as provided in R.S. 23:1201(E) from the date of receipt of the complete electronic medical bill.

b. The remittance advice must clearly indicate the reason for the denial.

7. Acceptance of an incomplete medical bill does not satisfy the written notice of injury requirement from an employee or insurance carrier as required in R.S. 23:1306.

8. Functional acknowledgment under Section 309.D.3 of this Chapter, and acceptance of a complete, structurally correct file serves as proof of the received date for an electronic medical bill in Section 309.C of this Chapter.

### E. Electronic Documentation

1. Electronic documentation must be submitted with the electronic medical bill.

2. Electronic documentation shall be provided pursuant to Section 309.C of this Chapter.

### F. Remittance Notification

1. An electronic remittance notification is an explanation of medical benefits (EOMB) or explanation of review (EOR), submitted electronically regarding payment or denial of a medical bill.

2. Upon mutual agreement, an insurance carrier may provide an electronic remittance notification.

3. The electronic remittance notification must contain the appropriate group claim adjustment reason codes, claims adjustment reason codes (CARC) and associated remittance advice remark codes (RARC) as specified by ASC X12 835N implementation guide or for pharmacy charges, the National Council for Prescription Drugs Program (NCPDP) reject codes, denoting the reason for payment, adjustment, or denial.

4. The remittance notification must be released within one business day of the payment or denial.

G. A health care provider or its agent may not submit a duplicate paper medical bill earlier than 60 business days from the date originally submitted unless the insurance carrier has returned the medical bill as incomplete in accordance with Section 311 (employer, insurance carrier, managed care organization, or agents' receipt of medical bills from health care providers). A health care provider or its agent may submit a corrected electronic medical bill to the insurance carrier after receiving notification of a rejection. The corrected medical bill is submitted as a new, original bill.

H. An insurance carrier or its agent may not reject a standard transaction on the basis that it contains data elements not needed or used by the insurance carrier or its agent.

I. A health care provider that is not able to send a standard transaction may use an internet-based direct data entry system offered by an insurance carrier if the insurance carrier does not charge a transaction fee. A health care provider using an internet-based direct data entry system offered by an insurance carrier or other entity must use the appropriate data content and data condition requirements of the standard transactions.

AUTHORITY NOTE: Promulgated in accordance with R.S. 23:1203.2.

HISTORICAL NOTE: Promulgated by the Louisiana Workforce Commission, Office of Workers' Compensation, LR 37:3544 (December 2011).

### **§311. Employer, Insurance Carrier, Managed Care Organization, or Agents' Receipt of Medical Bills from Health Care Providers**

A. Upon receipt of medical bills submitted in accordance with Sections 305, 307, and 309 of this Chapter, an



insurance carrier shall evaluate each bill's conformance with the criteria of a complete medical bill.

B. The received date of an electronic medical bill is the date all of the contents of a complete electronic bill are successfully received by the insurance carrier.

C. The insurance carrier may contact the medical provider to obtain the information necessary to make the bill complete.

1. Any request by the insurance carrier or its agent for additional documentation to pay a medical bill shall:

a. be made by telephone or electronic transmission or through web portal access if available unless the information cannot be sent by those media, in which case the sender shall send the information by mail or personal delivery;

b. be specific to the bill or the bill's related episode of care;

c. describe with specificity the clinical and other information to be included in the response;

d. be relevant and necessary for the resolution of the bill;

e. be for information that is contained in or in the process of being incorporated into the injured employee's medical or billing record maintained by the health care provider; and

f. indicate the specific reason for which the insurance carrier is requesting the information.

2. If the insurance carrier or its agent obtains the missing information and completes the bill to the point it can be adjudicated for payment, the insurance carrier shall document the name and telephone number of the person who supplied the information.

D. An insurance carrier shall not return a medical bill except as provided in Subsection A of this Section. When returning an ASC X12N 837 medical bill, the insurance carrier shall clearly identify the reason(s) for returning the bill by utilizing the appropriate reason and rejection code identified in the standards identified in Section 305.A of this Chapter.

E. The proper return of an incomplete medical bill in accordance with this Section fulfills the obligation of the insurance carrier to provide to the health care provider or its agent information related to the incompleteness of the bill.

F. Insurance carriers must timely reject bills or request additional information needed to reasonably determine the amount payable.

1. For bills submitted electronically, the rejection of all or part of the bill must be sent to the submitter within two business days of receipt.

2. If bills are submitted in a batch transmission, only the specific bills failing edits shall be rejected.

G. If an insurance carrier has reason to challenge the coverage or amount of a specific line item on a bill, but has no reasonable basis for objections to the remainder of the bill, the uncontested portion must be paid timely, as in Subsection H of this Section below.

H. Payment of all uncontested portions of a complete medical bill shall be made within 30 calendar days of receipt of the original bill, or receipt of additional information requested by the insurance carrier allowed under the law. Amounts paid after this 30 calendar day review period shall be subject to R.S. 23:1201(F).

I. An insurance carrier shall not return a medical bill except as provided in Section 311.A of this Chapter. When returning a medical bill, the insurance carrier shall also communicate the reason(s) for returning the bill.

J. The insurance carrier's failure to comply with any requirements of this rule shall result in an administrative violation in accordance with LAC 40:109.A.

AUTHORITY NOTE: Promulgated in accordance with R.S. 23:1203.2.

HISTORICAL NOTE: Promulgated by the Louisiana Workforce Commission, Office of Workers' Compensation, LR 37:3546 (December 2011), amended by the Workforce Commission, Office of Workers' Compensation Administration, LR 41:2692 (December 2015).

**§313. Communication between Health Care Providers and Insurance Carriers**

A. Any communication between the health care provider and the insurance carrier related to medical bill processing shall be of sufficient specific detail to allow the responder to easily identify the information required to resolve the issue or question related to the medical bill. Generic statements that simply state a conclusion such as "insurance carrier improperly reduced the bill" or "health care provider did not document" or other similar phrases with no further description of the factual basis for the sender's position do not satisfy the requirements of this Section.

B. Utilization of the ASC X12N Reason Codes, or as appropriate, the NCPDP Reject Codes, by the insurance carrier when communicating with the health care provider or its agent or assignee, provides a standard mechanism to communicate issues associated with the medical bill.

C. Communication between the health care provider and insurance carrier related to medical bill processing shall be made by telephone or electronic transmission unless the information cannot be sent by those media, in which case the sender shall send the information by mail or personal delivery.

D. The insurance carrier's failure to comply with any requirements of this Rule shall result in an administrative violation LAC 40:109.A.

AUTHORITY NOTE: Promulgated in accordance with R.S. 23:1203.2.

HISTORICAL NOTE: Promulgated by the Louisiana Workforce Commission, Office of Workers' Compensation, LR 37:3546 (December 2011).

### §315. Medical Documentation Necessary for Billing Adjudication

A. Medical documentation includes all medical reports and records permitted or required in accordance with Title 40 of the *Louisiana Administrative Code*.

B. Any request by the insurance carrier for additional documentation to process a medical bill shall conform to the requirements of Section 311.C of this Chapter.

C. It is the obligation of insurance carriers to furnish its agents with any documentation necessary for the resolution of a medical bill.

D. Health care providers, health care facilities, third-party biller/assignees, and claims administrators and their agents must comply with all applicable federal and state rules related to privacy, confidentiality, and security.

AUTHORITY NOTE: Promulgated in accordance with R.S. 23:1203.2.

HISTORICAL NOTE: Promulgated by the Workforce Commission, Office of Workers' Compensation, LR 37:3547 (December 2011).

### §317. Compliance and Penalty

A. Any electronically submitted bill determined to be complete but not paid or objected to within 60 days shall be subject to penalties per R.S. 1201(F).

AUTHORITY NOTE: Promulgated in accordance with R.S. 23:1203.2.

HISTORICAL NOTE: Promulgated by the Louisiana Workforce Commission, Office of Workers' Compensation, LR 37:3547 (December 2011).

### §319. Effective Date

A. This Chapter applies to all medical services and products provided on or after July 1, 2013 for medical services and products provided prior to July 1, 2013, medical billing and processing shall be in accordance with the rules in effect at the time the health care was provided.

AUTHORITY NOTE: Promulgated in accordance with R.S. 23:1203.2.

HISTORICAL NOTE: Promulgated by the Workforce Commission, Office of Workers' Compensation, LR 37:3547 (December 2011).

## Chapter 7. Rehabilitation Services

### §701. Purpose

A. The purpose of this Section of administrative rule is to implement the provisions of R.S. 23:1226 and establish guidelines for the rehabilitation of the occupationally disabled employee.

B. The purpose of the Rehabilitation Program is to coordinate and assure the most efficient and timely delivery of the multiple services often necessary to restore the occupationally disabled employee to employment as soon as possible after the injury.

C. There are two major overlapping and interrelated components of the rehabilitation process:

1. vocational restorative services; and
2. reemployment services.

AUTHORITY NOTE: Promulgated in accordance with R.S. 23:1226.

HISTORICAL NOTE: Promulgated by the Department of Labor, Office of Workers' Compensation Administration, LR 11:778 (August 1985), repromulgated LR 13:307 (May 1987), repromulgated by the Department of Employment and Training, Office of Workers' Compensation Administration, LR 18:148 (February 1992).

### §703. Statutory Requirements

A. R.S. 23:1226(A) requires that when an employee has suffered an injury covered by Chapter 10, R.S. 23 which precludes the employee from earning wages equal to wages earned prior to the injury, the employee shall be entitled to prompt rehabilitation services provided by the carrier/employer.

B. R.S. 23:1226(B) requires that in considering the goal of returning a disabled worker to work with a minimum of retraining, the first appropriate option listed therein is to be chosen.

AUTHORITY NOTE: Promulgated in accordance with R.S. 23:1226.

HISTORICAL NOTE: Promulgated by the Department of Labor, Office of Workers' Compensation Administration, LR 11:778 (August 1985), repromulgated LR 13:307 (May 1987), repromulgated by the Department of Employment and Training, Office of Workers' Compensation Administration, LR 18:148 (February 1992).

### §705. Definitions

A. For purposes of this Section, the following definitions apply.

*Evaluation*—any testing, analysis or assessment of the occupationally disabled employee's physical and/or vocational capabilities used to determine the need for and practicability of rehabilitation services to restore the employee to gainful employment.

*Private Agencies*—companies which provide vocational rehabilitation services for a fee.

*Reemployment Services*—services used to reemploy the occupationally disabled employee in a suitable, gainful occupation as adjusted by his/her physical and vocational ability at that time.

*Rehabilitation*—the restoration of an occupationally injured or diseased employee to employment as soon as possible after the injury.

*Rehabilitation Services*—vocational and/or reemployment services necessary to restore an occupationally disabled employee, as nearly as possible, to his/her pre-injury status.

*State and Federal Agencies*—those agencies which provide vocational education paid for with tax money.

*Suitable Employment*—employment or self-employment, after rehabilitation which is reasonably

attainable and which offers an opportunity to restore the individual as soon as practical and nearly as possible to his average earnings at the time of this injury including any sheltered employment, odd-lot or employment while working in pain.

*Vocational Restorative Services*—vocational services needed to restore the occupationally disabled employee to his/her pre-injury employment or if that is not possible to that which he/she enjoyed prior to the occupational injury or disease. Such services include but are not limited to, the following: psychological and vocational evaluations, counseling and training services.

AUTHORITY NOTE: Promulgated in accordance with R.S. 23:1226.

HISTORICAL NOTE: Promulgated by the Department of Labor, Office of Workers' Compensation Administration, LR 11:778 (August 1985), repromulgated LR 13:308 (May 1987), repromulgated by the Department of Employment and Training, Office of Workers' Compensation Administration, LR 18:148 (February 1992).

#### **§707. Responsibility to Provide Service**

A. It is the responsibility of the carrier/employer to select a vocational counselor to evaluate and assist the employee in his job placement and/or vocational training.

AUTHORITY NOTE: Promulgated in accordance with R.S. 23:1226.

HISTORICAL NOTE: Promulgated by the Department of Labor, Office of Workers' Compensation Administration, LR 11:778 (August 1985), repromulgated LR 13:308 (May 1987), repromulgated by the Department of Employment and Training, Office of Workers' Compensation Administration, LR 18:148 (February 1992).

#### **§709. Use of Resources**

A. The carrier/employer may utilize programs provided by state and federal agencies for rehabilitation services when conveniently available or may utilize any public or private agency cooperating with such state and federal agencies. In the absence of such programs, the carrier/employer shall provide rehabilitation services with available private agencies.

AUTHORITY NOTE: Promulgated in accordance with R.S. 23:1226.

HISTORICAL NOTE: Promulgated by the Department of Labor, Office of Workers' Compensation Administration, LR 11:778 (August 1985), repromulgated LR 13:308 (May 1987), repromulgated by the Department of Employment and Training, Office of Workers' Compensation Administration, LR 18:148 (February 1992).

#### **§711. Claims**

A. A rehabilitation dispute or claim can be filed on Form LDET-WC-1005 by the employee, employer or carrier when rehabilitation services are not voluntarily offered or accepted. The hearing officer may consider written vocational rehabilitation evaluations and plans prepared by a private or public rehabilitation provider or counselor and/or may refer the employee to a qualified physician and/or approved facility, individual, institution or organization for the evaluation of the practicality, advisability and necessity

of rehabilitation services to restore the employee to suitable gainful employment. Any evaluation ordered by the hearing officer shall be completed in 45 days from the receipt of the referral from the hearing officer, with the expense of such evaluation to be borne by the employer/carrier.

B. If rehabilitation services are deemed practical and advisable, they shall be ordered at the expense of the carrier/employer subject to the reimbursement schedule for rehabilitation services promulgated at the time of the filing of the claim or dispute.

AUTHORITY NOTE: Promulgated in accordance with R.S. 23:1226.

HISTORICAL NOTE: Promulgated by the Department of Labor, Office of Workers' Compensation Administration, LR 11:778 (August 1985), repromulgated LR 13:308 (May 1987), repromulgated by the Department of Employment and Training, Office of Workers' Compensation Administration, LR 18:149 (February 1992).

#### **§713. Adjudication by Hearing Officer**

A. Prior to the hearing officer finding that an occupationally disabled employee is permanently and totally disabled, the hearing officer shall determine whether there is reasonable probability that, with appropriate rehabilitation services which may include training and/or education, the occupationally disabled employee can achieve suitable gainful employment and whether it is in the best interest of such individual to undertake such rehabilitation services.

AUTHORITY NOTE: Promulgated in accordance with R.S. 23:1226.

HISTORICAL NOTE: Promulgated by the Department of Labor, Office of Workers' Compensation Administration, LR 11:778 (August 1985), repromulgated LR 13:308 (May 1987), repromulgated by the Department of Employment and Training, Office of Workers' Compensation Administration, LR 18:149 (February 1992).

#### **§715. Duration**

A. When it appears that appropriate training and/or education is necessary and desirable to restore the occupationally disabled employee to suitable gainful employment, the employee shall be entitled to 26 weeks of training and/or education and an additional 26 weeks if deemed necessary and proper by the hearing officer. However, no carrier/employer shall be precluded from continuing such rehabilitation beyond such period on a voluntary basis. An occupationally disabled employee must request and begin rehabilitation within two years from the date of termination of temporary total disability as determined by the treating physician.

AUTHORITY NOTE: Promulgated in accordance with R.S. 23:1226.

HISTORICAL NOTE: Promulgated by the Department of Labor, Office of Workers' Compensation Administration, LR 11:778 (August 1985), repromulgated LR 13:308 (May 1987), repromulgated by the Department of Employment and Training, Office of Workers' Compensation Administration, LR 18:149 (February 1992).

**§717. Cost of Rehabilitation Services and Supplies**

A. When appropriate training and/or education is deemed necessary, the rehabilitation services provided shall include the cost of training, tuition, books, tools and/or equipment.

AUTHORITY NOTE: Promulgated in accordance with R.S. 23:1226.

HISTORICAL NOTE: Promulgated by the Department of Labor, Office of Workers' Compensation Administration, LR 11:778 (August 1985), repromulgated LR 13:308 (May 1987), repromulgated by the Department of Employment and Training, Office of Workers' Compensation Administration, LR 18:149 (February 1992).

**§719. Location of Services**

A. If rehabilitation requires residence at or near the facility or institution away from the occupationally disabled employee's customary residence, reasonable costs of his/her board, lodging and travel shall be paid for by the employer/carrier. A retraining program shall be provided at facilities within the state when such facilities are available.

AUTHORITY NOTE: Promulgated in accordance with R.S. 23:1226.

HISTORICAL NOTE: Promulgated by the Department of Labor, Office of Workers' Compensation Administration, LR 11:778 (August 1985), repromulgated LR 13:308 (May 1987), repromulgated by the Department of Employment and Training, Office of Workers' Compensation Administration, LR 18:149 (February 1992).

**§721. Penalty for Refusal**

A. Although an occupationally disabled employee is entitled to rehabilitation as a right or benefit, when he/she agrees to a rehabilitation program, dedication to the completion of that program is expected.

B. Demonstration of a lack of responsibility by the occupationally disabled employee in following through with the rehabilitation plan or refusal to accept rehabilitation as deemed necessary by the hearing officer shall result in a 50 percent reduction in weekly compensation, including supplemental earnings benefits pursuant to R.S. 23:1221(3), for each documented week of the period of refusal.

AUTHORITY NOTE: Promulgated in accordance with R.S. 23:1226.

HISTORICAL NOTE: Promulgated by the Department of Labor, Office of Workers' Compensation Administration, LR 11:778 (August 1985), repromulgated LR 13:308 (May 1987), repromulgated by the Department of Employment and Training, Office of Workers' Compensation Administration, LR 18:149 (February 1992).

**§723. Payment of Temporary Disability**

A. Temporary disability benefits paid pursuant to R.S. 23:1221(1) shall include such period as may be reasonably required for training in the use of artificial members and appliances and shall include such period as the employee may be receiving training or education under a rehabilitation program approved by the hearing officer.

AUTHORITY NOTE: Promulgated in accordance with R.S. 23:1226.

HISTORICAL NOTE: Promulgated by the Department of Labor, Office of Workers' Compensation Administration, LR 11:778 (August 1985), repromulgated LR 13:308 (May 1987), repromulgated by the Department of Employment and Training, Office of Workers' Compensation Administration, LR 18:149 (February 1992).

**§725. Approved List of Rehabilitation Providers**

A. The Office of Workers' Compensation Administration will maintain a current listing of rehabilitation counselors licensed to practice rehabilitation services in the state of Louisiana. This listing will be available upon request.

AUTHORITY NOTE: Promulgated in accordance with R.S. 23:1226.

HISTORICAL NOTE: Promulgated by the Department of Labor, Office of Workers' Compensation Administration, LR 11:778 (August 1985), repromulgated LR 13:309 (May 1987), repromulgated by the Department of Employment and Training, Office of Workers' Compensation Administration, LR 18:149 (February 1992).

**Chapter 9. Safety Requirements****§901. Statutory Requirements**

A. R.S. 23:1291(B)(4), as amended, requires every Louisiana employer of more than 15 employees to provide, if self-insured, or is provided by the carrier, if privately insured, plans for implementation of a working and operational safety plan. The plans shall be made available for inspection by the director upon request. The plan shall be privileged and confidential pursuant to R.S. 23:1293, provided that the operational safety plan may be subpoenaed from the employer who shall certify under oath that it is a duplicate of the plan submitted to the director.

B. In order to ensure adequate safety resources for Louisiana employers and employees, the director shall maintain a list of safety professionals/engineers from the private sector, which shall be available upon request by any Louisiana employer.

AUTHORITY NOTE: Promulgated in accordance with R.S. 23:1291.

HISTORICAL NOTE: Promulgated by the Department of Labor, Office of Workers' Compensation Administration, LR 11:778 (August 1985), repromulgated LR 13:309 (May 1987), repromulgated by the Department of Employment and Training, LR 17:176 (February 1991), amended by the Department of Labor, LR 19:755 (June 1993).

**§903. Definitions**

*Operational Safety Plan*—this document of undetermined length will present simply and clearly the program which the employer can follow to reduce accidents in the work place and incidences of industrial and occupational disease. The safety plan shall comply with applicable local, state and federal safety and health standards or appropriate industry standards. To assist in the development of the components of the safety plan, the employer may utilize:

1. an in-house safety staff;
2. insurance carrier field safety representative; or

3. private sector safety professionals/engineers as identified by a list maintained by the director. The components of a safety plan shall be outlined in §907.

*Professional Safety Experience*—the responsible charge of 75 percent or more of one's duties and functions is for the successful accomplishment of safety objectives such as the analysis, investigation, planning, execution of safety plans, feedback adjustments and the periodic audit of the program. Responsible charge does not imply supervisory responsibility.

\**Safety Professional/Engineer*—an active safety practitioner who possesses one or a combination of the following criteria:

1. graduation from an accredited college or university with a bachelor's degree in engineering or science, plus five years or more of professional safety experience, of which two or more years shall have been in responsible charge. A master's degree will be accepted in lieu of one year of the practitioners professional safety experience. An earned doctoral degree will be accepted in lieu of two years of the practitioner's professional safety experience;

2. an earned associate degree from an accredited college or university in engineering or science plus eight years or more professional safety experience;

3. ten years of professional safety experience in lieu of an engineering or science degree;

4. professional certifications:

- a. certified safety professional;
- b. certified hazard control manager;
- c. certified industrial hygienist;

d. safety professional/engineers. To ensure adequate safety resources to the employer, the safety practitioner/engineer shall provide the following consultation services which will consist of, but not be limited to the following:

- i. review the safety performance of the employer's organization, activities and operations;
- ii. appraise the mechanical hazards, power transmission apparatus, material handling, unsafe work methods, hazardous processes and hazardous environments;
- iii. advise and assist in the detection of occupational health hazards and exposure;
- iv. provide assistance to the employer in the development of employee safety training programs;
- v. make recommendations for appropriate safety corrective actions to be taken; and
- vi. assist in the development of an employer's safety plan in compliance with LWC-15.

\*These requirements apply to individuals who are making application to the director for placement on the list of private sector safety professionals/engineers for safety services.

**AUTHORITY NOTE:** Promulgated in accordance with R.S. 23:1291.

**HISTORICAL NOTE:** Promulgated by the Department of Labor, Office of Workers' Compensation Administration, LR 11:778 (August 1985), amended LR 13:309 (May 1987), repromulgated by the Department of Employment and Training, LR 17:177 (February 1991), amended by the Department of Labor, LR 19:755 (June 1993).

### §905. Availability of Safety Services

A. The director shall maintain a list from the private sector of safety practitioners who meet the criteria as set forth in the definition of a safety professional/engineer in §903. This list shall be made available to any Louisiana employer upon request.

B. In-house safety staff shall be a full-time employee(s) whose primary function within the organization includes work of progressive importance and achievement towards accident prevention.

C. Insurance carrier safety staffs are full-time employees whose primary functions include safety engineering services.

**AUTHORITY NOTE:** Promulgated in accordance with R.S. 23:1291.

**HISTORICAL NOTE:** Promulgated by the Department of Labor, Office of Workers' Compensation Administration, LR 11:779 (August 1985), amended LR 13:308 (May 1987), repromulgated by the Department of Employment and Training, LR 17:177 (February 1991), amended by the Department of Labor, LR 19:755 (June 1993).

### §907. Classes and Components of Safety Plan

A. The two classes of operating safety plans and their minimum requirements shall be as follows.

1. *Class A*—The Class A Safety Plan is required when the employer's Workers' Compensation premium rate is over \$5 premium per \$100 of payroll for the major job classification or the job classification with the highest amount of payroll. The minimum requirements are as follows.

a. *Management Policy Statement.* This document shall be signed by the top executive of the company acknowledging management's responsibility and commitment to a safety plan and their intention to comply with all applicable local, state and federal safety requirements and appropriate industry standards. Management shall commit resources, responsibility and accountability to all levels of management and to each employee for the safety program.

b. *Responsibility for safety* shall be defined in writing for executive and middle level operating management, supervisors, safety coordinator and employees.

c. *Inspections* shall be made of all areas of the work place at least monthly by a supervisor at the site. A written report (checklist or narrative) is to be completed for each inspection, with this report to be retained for a period of one year. The report will be designed to cover the identification of recognized unsafe conditions, unsafe acts and any other items inherent in a particular job. The form will include a

space to indicate any corrective action taken. The responsibility for the correction of defects is to be designated by management.

d. Accident Investigation

i. An accident investigation of any job related injury that requires a visit to a clinic or physician shall be initiated by the injured employee's supervisor as soon as possible on the shift the accident occurs. The accident investigation report will include information required to determine the basic causes of the accident by asking the questions who, what, where, who, when and how. Corrective action to be taken and/or recommended to prevent a recurrence of a similar accident will be implemented. Complex accidents may require technical assistance to ensure an accurate investigation, however, the injured employee's supervisor should be included on the investigation team.

ii. The accident investigation report shall include information on the injured person, his or her job, what happened, basic causes, corrective actions required, the time frame to make corrections and who will be responsible for seeing that corrections are implemented.

e. Safety Meetings

i. Safety meetings shall be held by a supervisor with all of his/her employees on a monthly basis. A record will be kept showing the topics discussed, date of meeting and the names of the persons attending.

ii. Safety meeting topics will be designed to instruct the employee on how to perform his job productively, efficiently and safely. Hazard recognition and hazard control procedures; selection, use and care of personal protective equipment; job procedures review and good housekeeping are examples of the information employees should receive at a safety meeting.

iii. A review of the recent work area inspection results, the workers' compliance with safety procedures, and the accident investigations that occurred since the last safety meeting should be covered in the safety meeting.

f. Safety Rules. Management shall develop specific safety rules that apply to the operations being performed. The rules should be short, concise, simple, enforceable and stated in a positive manner. The safety rules are to be followed and adhered to by all management personnel and all employees. The rules shall be written with a copy provided to each employee and documented.

g. Training. Management shall implement a training program that will provide for orientation and training of each new employee, existing employees on a new job or when new equipment, processes or job procedures are initiated. The training provided will consist of, but not limited to, the correct work procedures to follow, correct use of personal protective equipment required and where to get assistance when needed. This training should be accomplished by the employee's supervisor but may be done by a training specialist or an outside consultant such as a vendor or safety

consultant. Training shall be provided to all persons in operating supervisory positions in conducting safety meetings, conducting safety inspections, accident investigation, job planning, employee training methods, job analysis and leadership skills.

h. Record Keeping. In addition to OSHA logs which are retained for five years (federal requirement), each firm shall maintain other safety records for a period of one year from the end of the year for which the records are maintained (state requirement). These will include inspection reports, accident investigation reports, minutes of safety meetings, training records and the LDET-WC-1071A Form.

i. First Aid. Management shall adopt and implement a first aid program which will provide for a trained first aid person at each job site on each shift. A first aid kit with proper supplies for the job exposures will be maintained and restocked as needed. Emergency phone numbers for medical services and key company personnel must also be maintained.

j. Emergency Preparedness Program

i. Management shall develop a written emergency preparedness plan to ensure to the extent possible the safety of all employees, visitors, contractors and vendors in the facility at the time of emergency situations, such as but not limited to natural disasters, fire, explosions, chemical spills and/or releases, bomb threats and medical emergencies. Emergency shutdown and start-up procedures will be developed in industries having equipment that requires several steps to properly shutdown and secure. Employees shall be trained in these procedures to reduce the incidences of additional injuries, property damage and possible release of hazardous materials to the environment. Emergency plans shall comply with all governmental regulations and state and local emergency response committee requirements.

ii. All employees and contractors shall be trained in the facility's emergency plan. A facility training drill will be conducted at least annually to test the emergency plan. The emergency plan will be reviewed annually and revised as required. Employees shall be trained in the updated emergency plan. Monthly inspections of all access and egress aisles and doors will be conducted to determine that they are clear, unobstructed and operable. Evacuation routes shall be posted in all work areas showing primary and secondary routes for employees' evacuation to a safe predetermined location for a head count.

2. *Class B*—The Class B Safety Plan is required when the employer's Workers' Compensation premium rate is \$5 premium or less per \$100 of payroll for the major job classification or the job classification with the highest amount of payroll. The minimum requirements are as follows:

- a. management policy statement—the same as Class A;
- b. definition of responsibility—the same as Class A;

- c. inspections—the same as Class A except that inspections are required to be conducted quarterly;
- d. accident investigation—the same as Class A;
- e. safety meetings—the same as Class A except that safety meetings are required to be conducted quarterly;
- f. safety rules—the same as Class A;
- g. training—the same as Class A;
- h. record keeping—the same as Class A;
- i. first aid—the same as Class A;
- j. Emergency Preparedness Program—the same as Class A.

3. Note: The above items listed for Class A and Class B plans are considered to be the minimum requirements and should be referred to as such. Obviously, we would all like to see such items as planning, cost containment procedures, setting of objectives, performance evaluations, incentive programs, etc. included in an employer's safety plan.

4. The minimum requirements are in no way intended to require the revision of existing company safety plans that have demonstrated proven performance in the past. Any company that has a plan which meets or exceeds these minimum requirements may submit its plan to the director for review and acceptance.

AUTHORITY NOTE: Promulgated in accordance with R.S. 23:1291.

HISTORICAL NOTE: Promulgated by the Department of Labor, Office of Workers' Compensation Administration, LR 11:779 (August 1985), repromulgated LR 13:308 (May 1987), repromulgated by the Department of Employment and Training, LR 17:177 (February 1991), amended by the Department of Labor, LR 19:756 (June 1993).

**§909. Submission of Safety Plan**

A. Safety plans shall be submitted to the director upon request.

AUTHORITY NOTE: Promulgated in accordance with R.S. 23:1291.

HISTORICAL NOTE: Promulgated by the Department of Labor, Office of Workers' Compensation Administration, LR 11:779 (August 1985), repromulgated LR 13:310 (May 1987), repromulgated by the Department of Employment and Training, LR 17:178 (February 1991), amended by the Department of Labor, LR 19:757 (June 1993).

**§911. Employee Notice**

A. It shall be the employer's duty to advise employees and keep posted at some convenient and conspicuous point in his place of business a notice reading substantially as follows.

LOUISIANA DEPARTMENT OF LABOR  
 OFFICE OF WORKERS' COMPENSATION  
 ADMINISTRATION  
 POST OFFICE BOX 94040  
 BATON ROUGE, LA 70804-9040

1. Notice of Compliance to Employees

a. You should report to your employer any occupational disease or personal injury that is work related, even if you deem it to be minor.

b. In case of occupational disease, all claims are barred unless the employee files a claim with his employer within six months of the date that:

- i. the disease manifests itself;
- ii. the employee is disabled as a result of the disease; and
- iii. the employee knows or has reasonable grounds to believe that the disease is occupationally related.

2. In case of death arising from an occupational disease, all claims are barred unless the dependent(s) files a claim with the deceased employee's employer within six months of:

- a. the date of death; and
- b. the date the claimant has reasonable grounds to believe that the death resulted from an occupational disease.

3. In case of personal injury or death arising out of an in the course of employment, an injured employee, or any person claiming to be entitled to compensation either as a claimant or as a representative of a person claiming to be entitled to compensation, must give notice to the employers within 30 days of the injury. If notice is not given within 30 days, no payments will be made under the law for such injury or death.

4. The above mentioned claims should be filed with the employer at the address shown below.

5. In the event you are injured, you are entitled to select a physician of your choice for treatment. The employer may choose another physician and arrange an examination which you would be required to attend.

6. In order to preserve your right to benefits under the Louisiana Workers' Compensation Law, you must file a formal claim with the Office of Workers' Compensation Administration within one year after the accident if payments have not been made or within one year after the last payment of weekly benefits.

7.a. This notice shall be given by delivering it or sending it by certified mail or return receipt requested to:

_____
Employer Representative
_____
Employer Name
_____
Address
_____
City
_____
State and Zip

b. Inaccuracies in this notice of disease, injury, or death regarding the time, place, nature, or the cause of injury or otherwise will not be held against the employee unless the employer can show harm from being misled about the facts.

8. Failure to give notice may not harm the employee if the employer knew of the accident or if the employer was not prejudiced by the delay or failure to give notice. (Refer to R.S. 23:1304 and 1305 for the exact wording.)

9. If you desire any information regarding your rights and entitlement to benefits as prescribed by law, you may call or write to the Office of Workers' Compensation Administration at the above address, or telephone (225) 342-7555 or toll-free (800) 824-4592.

10. This notice should be posted conspicuously in and about employer's place(s) of business.

11. If the employer is insured, then include the name and address of insurance company.

12. If the employer fails to keep such a notice posted, the time in which the notice of injury shall be given shall be extended to 12 months from the date of the injury.

AUTHORITY NOTE: Promulgated in accordance with R.S. 23:1302.

HISTORICAL NOTE: Promulgated by the Department of Labor, Office of Workers' Compensation Administration, LR 11:779 (August 1985), repromulgated LR 13:308 (May 1987), repromulgated by the Department of Employment and Training, LR 17:178 (February 1991), amended by the Department of Labor, LR 19:757 (June 1993).

**§913. Lost Time Injury Reports**

A. Within 10 days of actual knowledge of injury to an employee which results in death or in lost time in excess of one week after the injury, the employer shall report same to the carrier, if any, and to the office on Form LDET-WC-1007.

AUTHORITY NOTE: Promulgated in accordance with R.S. 23:1306.

HISTORICAL NOTE: Promulgated by the Department of Labor, Office of Workers' Compensation Administration, LR 11:780 (August 1985), repromulgated LR 13:308 (May 1987), repromulgated by the Department of Employment and Training, LR 17:179 (February 1991), amended by the Department of Labor, LR 19:758 (June 1993).

**Chapter 11. Workers' Compensation Insurance Cost Containment**

**§1101. Purpose**

A. The purpose of these rules is to establish and implement effective injury control measures for employers in high rate classifications with insurance experience modifier rates of 1.5 or greater.

AUTHORITY NOTE: Promulgated in accordance with R.S. 23:1178.

HISTORICAL NOTE: Promulgated by the Department of Labor, Office of Workers' Compensation Administration, LR 19:896 (July 1993).

**§1103. Forms; Preparation and Adoption; Use**

A. The Office of Workers' Compensation shall prepare and adopt such forms for use in workers' compensation cost containment as it may deem necessary and advisable. Whenever the Office of Workers' Compensation's forms are

prescribed and are applicable, they shall be used. A photo ready copy of any form may be procured upon request to the office.

B. The following forms have been adopted by the Office of Workers' Compensation Administration for use in implementation of the Workers' Compensation Cost Containment Act.

Forms	
LDOL-WC-Form No. 1021	Application for Attendance at Cost Containment Meeting
LDOL-WC-Form No. 1022	Certificate of Attendance
LDOL-WC-Form No. 1023	Application for Implementation of Occupational Safety and Health Program
LDOL-WC-Form No. 1024	Certificate of Satisfactory Implementation of Occupation Safety and Health Program

AUTHORITY NOTE: Promulgated in accordance with R.S. 23:1178.

HISTORICAL NOTE: Promulgated by the Department of Labor, Office of Workers' Compensation Administration, LR 19:896 (July 1993).

**§1105. Cost Containment Meeting**

A. A number of statewide meetings shall be held between June and September of each year. A notice of all the meetings scheduled for that year shall be sent to all *eligible employers* as defined in R.S. 23:1176. Eligible employers who have not qualified for a reduction in the prior three years shall be sent by certified mail return receipt requested at least 30 days prior to the first scheduled meeting.

AUTHORITY NOTE: Promulgated in accordance with R.S. 23:1178.

HISTORICAL NOTE: Promulgated by the Department of Labor, Office of Workers' Compensation Administration, LR 19:896 (July 1993).

**§1106. Experience Modifier Rates**

A. An employer's eligibility shall be based on its experience modifier rate of December 31 of the prior year.

B. The incentive discount provided in R.S. 23:1178(C) shall be based on the employers next effective experience modifier rate after its certified attendance at a cost containment meeting. The certificate of attendance as issued by the Department of Labor, Office of Workers' Compensation, shall be valid only during the period of the employer's next effective experience modifier rate following its certified attendance at a cost containment meeting.

AUTHORITY NOTE: Promulgated in accordance with R.S. 23:1178.

HISTORICAL NOTE: Promulgated by the Department of Labor, Office of Workers' Compensation Administration, LR 19:544 (July 1993), amended by Department of Labor, Office of Workers' Compensation, LR 21:272 (March 1995).

**§1107. Application for Attendance at Cost Containment Meeting**

A. A verified application Form LDOL-WC-Form No. 1021 together with proof that the attendee is a person in a position of authority within the company must be received 15 days prior to the scheduled meeting to guarantee



consideration. Proof may include but shall not be limited to a verified job description, annual report to Secretary of State, copy of the preprinted tax form or act of partnership. Notice shall be given five days prior to the meeting if the office finds that the designated attendee is not a person in a position of authority within the company.

AUTHORITY NOTE: Promulgated in accordance with R.S. 23:1178.

HISTORICAL NOTE: Promulgated by the Department of Labor, Office of Workers' Compensation Administration, LR 19:896 (July 1993).

**§1109. Proof of Attendance; Certificate**

A. In order to obtain a certificate of attendance, LDOL-WC-Form No. 1022 at a cost containment meeting, the attendee must have qualified as a designated representative as defined in R.S. 23:1176(1). At the meeting the designated representative shall submit pictured identification and sign the roles of attendance. The certificate shall thereafter be mailed to those eligible employers who have not qualified for a reduction in the prior three years. Any application received within 15 days prior to a meeting may not be considered.

AUTHORITY NOTE: Promulgated in accordance with R.S. 23:1178.

HISTORICAL NOTE: Promulgated by the Department of Labor, Office of Workers' Compensation Administration, LR 19:896 (July 1993).

**§1111. Failure to Attend; Fines**

A. After the last scheduled meeting of a year the director upon verification of notice and failure to attend shall send a notice of fine to all eligible employers as provided in R.S. 23:1178.D.

AUTHORITY NOTE: Promulgated in accordance with R.S. 23:1178.

HISTORICAL NOTE: Promulgated by the Department of Labor, Office of Workers' Compensation Administration, LR 19:896 (July 1993).

**§1113. Application for Participation in the Occupational Safety and Health Program**

A. Only eligible employers who have certificate of attendance Form LDOL-WC-Form No. 1022 issued within the last four years may apply for participation in the Occupational Safety and Health Program.

B. An application for participation in the Occupational Safety and Health Program shall consist of the following:

1. a properly completed Form LDOL-OWC 1023;
2. a copy of the applicant's OSHA 200 log from the previous year;
3. a sworn statement that:
  - a. the company has written safety programs and training documentation as required by OSHA standards relevant to its facility for at least a six-month period;

b. the applicant's lost workday incident rate is less than the national average for its respective Standard Industrial Classification (SIC) code; and

c. the applicant company has experienced no fatalities within the 24 months immediately preceding the date of the application; and

4. any additional information which the Occupational Safety and Health Section of the Office of Workers' Compensation Administration deems necessary to evaluate the application.

**C. Application Rejection**

1. The Occupational Safety and Health Section of the Office of Workers' Compensation Administration may reject:

a. any application which does not contain all requested information or which does not reflect a commitment to safety in the workplace; and

b. an application at any time before the initial phase inspection is completed if it is determined that the company's application contained false information or that a fatality has occurred since the application was submitted.

2. A company whose application is rejected due to a lack of commitment to safety or for an application containing false information shall be allowed to reapply no earlier than 12 months from the date of the rejection notice.

D. In scheduling surveys the OWCA will attempt to schedule on the basis of the date the application is received in the office but shall also consider the OSHA High Hazard list and geographical location for maximizing scheduling.

AUTHORITY NOTE: Promulgated in accordance with R.S. 23:1178.

HISTORICAL NOTE: Promulgated by the Department of Labor, Office of Workers' Compensation Administration, LR 19:896 (July 1993), amended LR 21:814 (August 1995).

**§1115. Report to the Employer**

A. Upon completion of surveys of all existing sites of a business, OSHA shall issue to the employer an official inspection report with identified hazards and safety program deficiencies and a timetable for taking corrective actions.

AUTHORITY NOTE: Promulgated in accordance with R.S. 23:1178.

HISTORICAL NOTE: Promulgated by the Department of Labor, Office of Workers' Compensation Administration, LR 19:897 (July 1993).

**§1117. Standard for Satisfactory Implementation**

A. The standards used by the Office of Workers' Compensation Administration, OSHA section, in determining a participant's satisfactory implementation of the Occupational Safety and Health Program shall be those provided in Title 29 of the Code of Federal Regulations, Sections 1910, 1915, 1918 and 1926 and any regulations of ANSI, NEC and NFPA applicable to the participant.

AUTHORITY NOTE: Promulgated in accordance with R.S. 23:1178.

HISTORICAL NOTE: Promulgated by the Department of Labor, Office of Workers' Compensation Administration, LR 19:897 (July 1993).

**§1119. Inspections**

A. When the official inspection report contains any recommendation for correction of hazards or program deficiencies the employer must submit proof of compliance. The OSHA section may require a follow up inspection to verify satisfactory implementation.

AUTHORITY NOTE: Promulgated in accordance with R.S. 23:1178.

HISTORICAL NOTE: Promulgated by the Department of Labor, Office of Workers' Compensation Administration, LR 19:897 (July 1993).

**§1121. Certificate of Satisfactory Implementation**

A. A certificate of satisfactory implementation LDOL-WC-Form No. 1024 shall be issued only to those eligible employers who have not qualified for a reduction pursuant to R.S. 23:1179.C in the prior three years.

AUTHORITY NOTE: Promulgated in accordance with R.S. 23:1178.

HISTORICAL NOTE: Promulgated by the Department of Labor, Office of Workers' Compensation Administration, LR 19:897 (July 1993).

**§1123. Cost Credit Earned from Satisfactory Implementation**

A. Any safety and health hazard survey of the work place by the OSHA section consultants, including an evaluation of the employer's safety and health program and on-site interviews with employers and employees under R.S. 23:1179, shall be on-site inspections. All permanent, temporary, and multiple work sites shall be subject to inspection.

B. The on-site inspection of each eligible employer who has attended an authorized cost containment meeting shall be made in two phases; namely, the initial phase and the follow-up phase. The OSHA section shall not determine whether an eligible employer has satisfactorily implemented the OSHA section's occupational safety and health program until the initial and follow-up phases are completed. The effective date of qualification or disqualification of such eligible employer shall be the date of the report issued after the initial and follow-up phases are completed.

1. The initial phase shall be the first of any safety and health hazard surveys of the work place by the OSHA section, including an evaluation of the employer's safety and health program and on-site interviews with employers and employees by the OSHA section. The effective date of the completion of the initial phase shall be the date that the correction of hazards report is received by the OSHA section. The correction of all hazards identified during the on-site visit shall be made within six months of the visit.

2. The follow-up phase shall be a safety and health hazard survey of the work place by the OSHA section, including an evaluation of the employer's safety and health program and on-site interviews with employers and

employees by the OSHA section. This follow-up phase shall be conducted no earlier than six months after the initial phase is completed.

3. Notwithstanding the provisions of §1123.B.2, the follow-up phase may be conducted earlier than six months after the initial phase is completed if the company has had an operational safety plan in effect for the prior 12 months, and if the company has satisfied all elements of management commitment and planning, hazard assessment, hazard correction and control, and safety and health training, as provided in Form Consultation-33, for the prior 12 months.

AUTHORITY NOTE: Promulgated in accordance with R.S. 23:1179.

HISTORICAL NOTE: Promulgated by the Department of Labor, Office of Workers' Compensation Administration, LR 21:36 (January 1995).

**§1125. Qualification for Cost Credit under R.S. 23:1179**

A. Employers shall be eligible for a reduction in their experience modifier rate pursuant to R.S. 23:1179 when all of the following conditions are met:

1. satisfactorily implementation of the OSHA section's occupational safety and health program when the initial and follow-up phases are completed;

2. a loss work day incident rate less than the national average for their respective SIC, as indicated on their completed OSHA 200 Form for the prior calendar year; and

3. no fatalities within the 24 months immediately preceding the initial inspection or, in the case of a reapplication, within the 24 months immediately preceding the date of the reapplication.

AUTHORITY NOTE: Promulgated in accordance with R.S. 23:1179.

HISTORICAL NOTE: Promulgated by the Department of Labor, Office of Workers' Compensation Administration, LR 21:37 (January 1995).

**§1127. Reapplication after Failure to Qualify**

A. An employer that fails to qualify for the reduction in the experience modifier rate under R.S. 23:1179 because of a determination that the employer has not satisfactorily implemented the OSHA section's occupational safety and health program or because of its loss work day incident rate, shall be allowed to reapply for the reduction in the experience modifier rate after 12 months from the date of the final report.

B. An employer that fails to qualify for the reduction in the experience modifier rate under R.S. 23:1179 because of a fatality shall be allowed to reapply no earlier than 24 months from the date of the fatality.

AUTHORITY NOTE: Promulgated in accordance with R.S. 23:1179.

HISTORICAL NOTE: Promulgated by the Department of Labor, Office of Workers' Compensation Administration, LR 21:37 (January 1995).

### **§1129. Employer Eligibility for Safety and Health Program Assessment**

A. Comprehensive program assessment shall be accomplished by category and by order that applications are received.

1. Category I shall consist of sites which have 250 employees or less, and 500 or less total employees at all sites controlled by the employer based on the average level of employment during the most recent 12 months. Sites operated by governmental agencies are specifically excluded.

2. Category II shall consist of all sites which do not meet the criteria of Category I.

AUTHORITY NOTE: Promulgated in accordance with R.S. 23:1179.

HISTORICAL NOTE: Promulgated by the Department of Labor, Office of Workers' Compensation Administration, LR 21:37 (January 1995).

### **§1131. Discount Application Period**

A. The incentive discount provided in R.S. 23:1179.B shall be based on the employer's next effective modifier rate after its certified satisfactory implementation of an approved occupational safety and health program. A certificate shall be issued by the Office of Workers' Compensation evidencing the satisfactory implementation of an occupational safety and health program. Such certificate shall be valid only during the period of the employer's next effective modifier rate after its certified satisfactory implementation of the approved occupational safety and health program.

AUTHORITY NOTE: Promulgated in accordance with R.S. 23:1179.

HISTORICAL NOTE: Promulgated by the Department of Labor, Office of Workers' Compensation Administration, LR 21:272 (March 1995).

## **Chapter 15. Drug Testing Programs in Job Related Accident Cases**

### **§1501. Introduction**

A. The following represents the text of the Office of Workers' Compensation Administration's scientific and technical guidelines for accident-related drug testing programs, as directed by Act 454 of the Regular Session of 1989. These guidelines address the mandatory scientific and technical requirements of drug testing protocols, including collection of specimens, chain of custody and laboratory analysis.

1. Laboratories may not deviate from the provisions of these guidelines without the written approval of the director of the Office of Workers' Compensation Administration, or his designee.

2. These guidelines are to be effective immediately upon promulgation. Laboratories currently operating drug testing programs are to bring their programs into compliance within 180 days of promulgation.

3. The director of the Office of Workers' Compensation Administration or his designee may routinely update these guidelines for the purpose of conforming them to advances in technology or providing additional guidance.

AUTHORITY NOTE: Promulgated in accordance with R.S. 23:1081(9).

HISTORICAL NOTE: Promulgated by the Department of Employment and Training, Office of Workers' Compensation, LR 16:851 (October 1990), repromulgated LR 17:773 (August 1991).

### **§1503. Scientific and Technical Requirements**

A. Compensation shall not be allowed to the employee who receives personal injury from a job-related accident if the injury was caused by the employee's intoxication. Compensation will not be precluded, however, where the intoxication resulted from activities which were in pursuit of the employer's interest or in which the employer procured the intoxicating beverage or substance and encouraged its use during the employee's work hours. When an employee receives personal injury from an accident arising out of and in the course of his employment, his employer may test the employee for alcohol, and for any drug identified in Schedules I, II, III, IV or V of 21 U.S.C. 812.

#### **B. Definitions**

*Aliquot*—a portion of a specimen used for testing.

*Confirmatory Test*—a second analytical procedure used to identify the presence of a specific drug or metabolite in a specimen. The confirmatory test must be different in technique and chemical principle from that of the initial test procedure to ensure reliability and accuracy. [At this time gas chromatography/mass spectrometry (GC/MS) is the only authorized confirmation method. Gas chromatography is authorized for confirmation of alcohol (ethanol) concentrations in specimens.]

*Initial Test*—a sensitive, rapid, and inexpensive immunoassay screen to eliminate true negative specimens from further consideration.

*Intralaboratory Chain of Custody*—procedures used by the laboratory to maintain control and accountability from the receipt of specimens until testing is completed, results reported, and while specimens are in storage.

AUTHORITY NOTE: Promulgated in accordance with R.S. 23:1081(9).

HISTORICAL NOTE: Promulgated by the Department of Employment and Training, Office of Workers' Compensation, LR 16:851 (October 1990), repromulgated LR 17:773 (August 1991).

### **§1505. Specimen Collection Procedures**

#### **A. Collection Site**

1. The collection site is a place where individuals present themselves for the purpose of providing urine, blood, breath or other specimens to be analyzed for abuse of drugs, including alcohol. The site must possess all necessary personnel, materials, equipment, facilities, and supervision to provide for the collection, security, temporary storage, and transportation (shipping) of specimens to a drug testing laboratory.

## LABOR AND EMPLOYMENT

2. Procedures must provide for the collection site to be secure. Proper chain of custody procedures must be executed by collectors when handling specimens. The handling and transportation of specimens from one authorized individual or place to another must always be accomplished through the use of chain of custody procedures.

### B. Collection Procedures

1. Procedures for providing specimens must allow reasonable privacy but may require a witness to prevent substitutions, contamination or adulteration of the specimen to be provided. Employers must take precautions to ensure that a specimen has not been adulterated, contaminated, or substituted during the collection procedure and that all information on the collection container and in the chain of custody form can be identified as belonging to a given individual. To ensure that unadulterated specimens are obtained, the following procedures outline the minimum precautions that shall be taken during the collection of specimens, in noncritical, ambulatory accident related testing.

a. At the collection site, if the specimen to be collected is urine, toilet bluing agents shall be placed in the toilet tanks, wherever possible, so that the reservoir of water in the toilet bowl always remains blue. The possibility of adulteration, substitution or contamination from other sources of water (e.g., shower, sink, etc.) in the enclosure where urination occurs should be prevented whenever possible.

b. Upon arrival at the collection site, the collector shall request the individual to present some type of photo identification. If the individual does not have proper identification, this shall be noted on the chain of custody form.

c. The collector shall ask the individual to remove any unnecessary outer garments (e.g., coat, jacket) that might conceal items or substances that could be used to tamper with or adulterate his/her specimen. Also, all personal belongings (e.g., purse, briefcase) must remain with the outer garments; the individual may, however, retain his/her wallet. The collector shall note any unusual behavior or appearance.

d. After washing his/her hands, the individual shall remain in the presence of the collector and not have access to water fountains, faucets, soap dispensers, or cleaning agents.

e. In a nonwitnessed collection, the individual may provide his/her specimen in the privacy of a stall or otherwise partitioned area that allows for individual privacy. The collector shall note any unusual behavior by the individual.

f. After the specimen has been provided and submitted to the collector, the individual should be allowed to wash his/her hands.

g. If the collection is nonwitnessed, immediately after collection, the collector shall measure the temperature of the specimen and conduct an inspection to determine the specimen's color and signs of contaminants. Any unusual findings resulting from the inspection must be included on the chain of custody form. If the temperature of the specimen is outside the range of 32.5-37.7°C/90.5-99.8°F, this gives rise to reasonable suspicion of adulteration/substitution, and another specimen should be collected, and both specimens shall be properly labeled and forwarded to the laboratory.

h. Both the individual being tested and the collector should keep the specimen in view at all times prior to its being sealed and labeled. If the specimen is transferred to a second container, the collector shall request the individual to observe the transfer of the specimen and the placement of a tamperproof seal over the container cap and down the sides of the container. The collector will place the identification label securely on the container.

i. The identification label should contain the date, employee's name, and any other identifying information provided/required by the employer. The tested individual shall initial the label on the specimen container. If the individual refuses to initial the label, this fact must be noted by the collector on the chain of custody form.

j. The collector shall complete the appropriate chain of custody form. The individual shall be asked to read and sign a certification statement regarding his/her specimen and be given an opportunity to provide notification of any information which the individual considers relevant to the test, including identification of currently or recently used prescription or nonprescription drugs, or other relevant medical information.

k. After the above procedures, the specimen and chain of custody form are now ready for shipment. If the specimen is not immediately prepared for shipment, it must be appropriately secured during temporary storage.

1. In the event blood is required, it should be collected in a tube containing sodium fluoride as a preservative. To insure no adulteration of the blood specimen, alcohol shall not be used as a disinfectant, but betadine, or its nonalcoholic equivalent, shall be used.

2. Note: During the performance of any part of the chain of custody procedures, it is essential that the specimen and custody documents be under the control of the involved collector.

a. If the collector must leave his/her work station momentarily, the specimen and custody form must be taken with him/her, or must be secured. After the collector returns to the work station, the custody process will continue. If the collector is leaving for an extended period of time, he/she should package the specimen for mailing prior to leaving the site.

b. If the specimen is to be collected from a critical, nonambulatory or unconscious employee, the collection procedures shall be left to the discretion of the treating

medical provider, and shall reasonably preclude adulteration, contamination or substitution. After the patient's condition is stabilized and the patient is conscious, he/she shall be asked to read and sign a certification statement regarding his/her specimen, and be given an opportunity to provide notification of any information which the individual considers relevant to the test, including identification of currently or recently used prescription or nonprescription drugs, or other relevant medical information.

C. Collection Control. Collectors shall always attempt to have the specimen or specimen container within sight before and after the collection. The containers shall be tightly capped, properly sealed, and labeled. A chain of custody form shall be utilized for maintaining control and accountability from point of collection to final disposition of specimens. With each transfer of possession, the chain of custody form shall be dated, signed by the individual releasing the specimen, signed by the individual accepting the specimen, and shall note the purpose for transferring possession. Every effort should be made to minimize the number of persons handling specimens.

D. Transportation to Laboratory. After collection of specimens, collectors shall arrange to ship the specimens to the drug testing laboratory. The specimens shall be placed in appropriate containers (specimen boxes or padded mailers) that are securely sealed to eliminate the possibility of tampering. Collectors shall sign and date across the tape sealing the containers and ensure that the chain of custody documentation is attached to each sealed container. An outer mailing wrapper shall be placed around each sealed container. Specimens may be delivered to the drug testing laboratory using either the United States Postal Service, commercial air freight, air express, or may be handcarried. It is unnecessary to send specimens by registered mail.

AUTHORITY NOTE: Promulgated in accordance with R.S. 23:1081(9).

HISTORICAL NOTE: Promulgated by the Department of Employment and Training, Office of Workers' Compensation, LR 16:851 (October 1990), repromulgated LR 17:773 (August 1991).

**§1507. Laboratory Analysis Procedures**

A. Receiving/Preparation

1. The laboratory must be secured at all times; procedures to control access by unauthorized personnel shall be in place. Upon receipt of specimens, accession personnel shall inspect packages for evidence of possible tampering and compare information on specimen containers with that on chain of custody forms. Any discrepancies shall be properly noted and described. Any direct evidence of tampering shall be reported immediately to the employer and shall also be noted on the chain of custody form which must accompany all specimens during laboratory possession.

2. Specimen containers and original chain of custody forms will normally be retained within the accession area until all analyses have been completed. Aliquots and intralaboratory chain of custody forms shall be used by laboratory personnel for conducting the initial and confirmatory tests.

B. Initial Test. If the initial drug test is negative, there shall be no confirmation test. The initial testing shall use an immunoassay which meets the requirements of the Food and Drug Administration for commercial distribution. The following initial cutoff levels shall be used when screening specimens to determine usage of these drugs or classes of drugs.

	Initial Test Level (ng/ml)
Marijuana Metabolite	50
Cocaine Metabolites	300
Morphine/Codeine	300
Phencyclidine	25
Amphetamines/Methamphetamines	1000
Alcohol/Ethanol	0.05 gram %/ml

1. These test levels are subject to change by the Office of Workers' Compensation, as advances in technology or other considerations may permit identification and quantification of these substances at lower concentrations.

2. The laboratory will use scientifically accepted initial cutoff levels when screening specimens for other drugs in 21 U.S.C. 812, Schedules I, II, III, IV and V.

3. Some specimens may be subjected to initial testing by methods other than immunoassays, where the latter are unavailable for the detection of specific drugs of special concern. These methods are thin layer, high pressure liquid, and/or gas chromatography. Alternate initial test methods and testing levels shall be submitted for written approval to the director of the Office of Workers' Compensation, or his designee.

C. Confirmatory Test. All specimens identified as positive on the initial test shall be confirmed using gas chromatography for alcohol (ethanol) and gas chromatography/mass spectrometry (GC/MS) techniques for drugs in 21 U.S.C. 812, Schedules I, II, III, IV and V at the following cutoff values.

	Confirmatory Test Level (ng/ml)
Marijuana Metabolite*	10
Cocaine Metabolites**	150
Morphine/Codeine	150
Phencyclidine	25
Amphetamines	300
* Delta-9-tetrahydrocannabinol-9-carboxylic acid	
** Benzoylcegonine	

1. These test levels are subject to change by the Office of Workers' Compensation as advances in technology or other considerations may permit identification and quantification of these substances at lower concentrations.

2. Confirmation methods and levels for other drugs tested shall be submitted by the employer to the director of the Office of Workers' Compensation, or his designee, for approval. In the absence of an accepted quantitative GC/MS assay procedure, preference will be given to a confirmation of qualitative identification by means of full-scan GC/MS analysis and quantification by an alternate chromatographic method. All methods shall meet commonly accepted analytical standards.

3. Proper chain of custody controls shall always be enforced during confirmation testing. Authorized confirmation technicians shall sign the chain of custody forms and be responsible for each specimen to be tested. The laboratory shall include sufficient safeguards to ensure that unauthorized personnel are prevented from gaining access to the confirmation laboratory.

#### D. Reporting Results

1. Test results shall be reported to the employer within an average of five working days of receipt of the specimens. The report should contain the specimen number assigned by the submitting employer, the drug testing laboratory accession number, and results of the drug tests. All specimens negative on the initial test or negative on the confirmatory test shall be reported as negative. Only specimens confirmed positive shall be reported positive for a specific drug. Results may be transmitted to the employer by various electronic means (e.g., teleprinter, facsimile, or computer) in a manner consistent with maintaining confidentiality. It is impermissible to provide results verbally by telephone. A certified copy of the original chain of custody form, signed by the laboratory director or laboratory certifying officer, shall be sent to the employer. Certified copies of all analytical results shall be available from the laboratory when requested by appropriate authority.

2. All records pertaining to a given specimen shall be retained by the drug testing laboratory for a minimum of two years.

E. Long-Term Storage. Specimens confirmed positive shall be retained and placed in properly secured long-term frozen storage for at least 365 days. Within this 365-day period, an employer, employee, or the director of the Office of Workers' Compensation Administration may request the laboratory to retain the specimen for additional periods of time. This ensures that the specimen will be available for a possible retest during any administrative or legal proceeding. If the laboratory does not receive a request to retain the specimen during the initial 365-day period, the specimen may be discarded.

F. Retesting Specimens. Should specimen reanalysis be required as a result of challenge or litigation, the quantitation of a drug or metabolite in a specimen may not be subject to the same testing level criteria that were used during the original analysis; some analytes deteriorate or are lost during freezing and/or storage.

G. Subcontractors. The drug testing laboratory shall perform all work with its own personnel and equipment, unless otherwise authorized by the employer or director of the Office of Workers' Compensation Administration. Subcontractors shall follow all procedures and regulations as set out in these rules.

H. Laboratory Facilities. Laboratories must comply with applicable provisions of any state licensure requirements. Laboratories must be able to perform, at the same facility, screening and/or confirmation tests for each drug or metabolite for which service is offered.

#### I. Laboratory Personnel

1. The scientific director of the drug testing laboratory shall meet the following criteria. He or she must hold a B.S. in pharmacology, toxicology, or analytical chemistry and have at least two years experience in analytical toxicology (the analysis of biological materials for drugs of abuse) and appropriate training and/or forensic applications of analytic toxicology (court testimony, research and publications in analytic toxicology of drug abuse, etc.). The director is responsible for ensuring that there are sufficient personnel with adequate training and experience to supervise and conduct the work of the drug testing laboratory.

2. A key individual in the laboratory is the certifying scientist (who may also be the laboratory scientific director); this individual reviews the standards, control specimens, and quality control of the data, together with the screening and confirmation test results. After having assured that all results are acceptable, this individual certifies the test results. The certifying scientist must have sound training in the sciences, specific training in the theory and practice of the procedures used, including the recognition of aberrant results, and familiarity with quality control procedures.

3. Supervisors of analysts must possess a B.S. degree in chemistry, or at least the education and experience comparable to a Medical Technologist certified by the American Society of Clinical Pathologists, MT(ASCP), or its equivalent. These individuals, also, must have training in the theory and practice of the procedures used, and understanding of quality control concepts. Periodic verification of their skills must be documented. Other technicians or nontechnical staff must possess the necessary training and skills for the task assigned. Inservice continuing education programs to meet the needs of all laboratory personnel are desirable. Personnel files must include resume of training and experience; certification or license, if any; references; job descriptions; health records; records of performance evaluation and advancement; incident reports; and results of tests for color blindness.

4. Laboratory screening personnel performing initial tests shall comply with personnel requirements to provide reasonable assurance of accuracy of test results.

J. Quality Assurance and Quality Control. Drug testing laboratories shall have a quality assurance program which encompasses all aspects of the testing process: specimen acquisition, chain of custody, security, and reporting of results, in addition to the screening and confirmation of analytical procedures. Quality control procedures will be designed, implemented, and reviewed to monitor the conduct of each step of the process.

K. Documentation. Documentation of all aspects of the testing process must be available. This documentation will be maintained for at least two years and shall include personnel files on analysts, supervisors, directors, and all individuals authorized to have access to specimens; chain of custody documents; quality assurance/quality control records; all test data; reports; performance records on

proficiency testing; performance records on accreditation inspections; and hard copies of computer-generated data.

L. Reports. All positive test results, including screening, confirmation, and quality control data must be reviewed by the certifying scientist or laboratory director before a test result is certified as accurate. The report shall identify the drugs/metabolites tested for, whether positive or negative, and the threshold concentration for each.

M. Judicial Proceedings. The laboratory must have qualified personnel available to testify in an administrative or legal proceeding against an employee which is based on a positive drug or alcohol result reported.

AUTHORITY NOTE: Promulgated in accordance with R.S. 23:1081(9).

HISTORICAL NOTE: Promulgated by the Department of Employment and Training, Office of Workers' Compensation, LR 16:853 (October 1990), repromulgated LR 17:774 (August 1991).

### §1509. Reporting and Review of Results

A. An essential part of the drug testing program is the final review of results. A positive test result does not automatically identify an employee as a drug abuser. A Medical Review Officer (MRO) with a detailed knowledge of possible alternate medical explanations must be involved in the review process.

1. *Medical Review Officer*—a licensed physician responsible for receiving laboratory results generated by employer or testing entities' drug testing program who has knowledge of substance abuse disorders and has appropriate medical training to interpret and evaluate an individual's positive test result together with his medical history and any other relevant biomedical information. The role of the MRO is to review and interpret positive test results obtained through the office's testing program. In the conduct of this responsibility, the MRO should undertake the examination of alternate medical explanations for a positive test result. This action could include conducting of employee medical interviews, review of employee medical history, or the review of any other relevant biomedical factors.

2. The MRO is required to review all medical records made available by the tested employee when a confirmed positive test could have resulted from legally prescribed medication. After the MRO has reviewed the pertinent information and the laboratory assessment is verified, the results are to be forwarded to the employer and the Office of Workers' Compensation. Should any question arise as to the veracity of a positive test result, the MRO is authorized to order a reanalysis of the original sample. If the MRO determines there is a legitimate medical explanation for the positive test result, MRO may deem that the result is consistent with legal drug use, and take no further action.

AUTHORITY NOTE: Promulgated in accordance with R.S. 23:1081(9).

HISTORICAL NOTE: Promulgated by the Department of Employment and Training, Office of Workers' Compensation, LR 16:854 (October 1990), repromulgated LR 17:776 (August 1991).

## Chapter 17. Fiscal Responsibility Unit

### §1701. Financial Compliance

A. Every employer subject to the jurisdiction of the Louisiana Workers' Compensation Act shall file with the Office of Workers' Compensation proof of its compliance with the workers' compensation insurance provision of the Act R.S. 23:1168. A notice from the insurer, on a form developed by the director, certifying compliance will be accepted as proof. The form must be received within 30 days of the policy's effective date.

AUTHORITY NOTE: Promulgated in accordance with R.S. 23:1168 and Act 938 of 1988 Regular Session.

HISTORICAL NOTE: Promulgated by the Department of Employment and Training, Office of Workers' Compensation, LR 17:960 (October 1991).

### §1703. Termination of Coverage by Insurance Carriers; Employer to Obtain New Coverage

A. Any insurance carrier desiring to cancel or terminate an insurance policy before the expiration date stated in the policy shall be required to give 20 days prior notice thereof in writing to the Office of Workers' Compensation, the employer, and the Commissioner of Insurance.

B. The employer whose policy has been canceled or terminated shall, on or before the twentieth day after receipt of the notice of cancellation or termination, file evidence with the Office of Workers' Compensation of having obtained other coverage in accordance with the Act. Failure on the part of the employer to file such evidence within 20 days shall be considered by the Office of Workers' Compensation as prima facie evidence of violation and subject the employer to the penalties prescribed under R.S. 23:1170 of the Act (effective July 1, 1989).

AUTHORITY NOTE: Promulgated in accordance with R.S. 23:1168 of Act 938 of 1988 Regular Session.

HISTORICAL NOTE: Promulgated by the Department of Employment and Training, Office of Workers' Compensation, LR 17:960 (August 1991).

### §1705. Definitions

A. When used in these rules, the following words or terms shall have the meaning as described in this Section.

*Certified Audit*—an audit upon which the auditor expresses his professional opinion that the accompanying statement presents fairly the financial position of the self-insurer or fund in conformity with generally accepted accounting principles consistently applied.

*Commutation*—a substitution, exchange or interchange of one security for another.

*Conditional Reserves*—acceptable assets equal to the security deposit requirement plus any additional contingent reserves established by the trustees or required by the office.

*Contingent Liability*—the amount that a self-insurer's fund may be obliged to pay in excess of a given fund year's standard premium collected or on hand. This liability is considered funded if a security deposit equal to the total

amount of the contingent liability has been posted. This liability is considered unfunded if a surety bond has been posted equal to all or a portion of the total amount of the contingent liability.

*Current Ratio*—the ratio of current assets to current liabilities as shown in the most recent financial statement.

*Loss Development*—the change in incurred loss from one point in time to another.

*Loss Fund*—the retention of liability for an individual self-insurer under the terms of an aggregate excess contract. In the absence of an aggregate excess policy, it is the amount of money allocated to pay claims.

*Manual Premium*—premium determined by multiplying the payroll (segregated into the proper workers' compensation job classifications) times the appropriate manual premium rates, or premiums tabulated on unspent payrolls, or limited payrolls as promulgated by the National Council on Compensation Insurance.

*Net Safety Factor*—any amount needed in a given fund year in addition to current loss reserves to fund future loss development.

*Office*—the Office of Workers' Compensation Administration.

*Service Company*—a business which has met all the requirements of §1713 of these rules and which has obtained office approval to contract with self-insurers for the purpose of providing all services necessary to plan and maintain an approved self-insurer program. The term *Service Agent* is synonymous with the term *Service Company* as used in these rules.

*Surplus*—all other assets a fund may have on hand in excess of all loss reserves, actual and contingent liabilities and net safety factors in all fund years.

*Working Capital or Net Current Assets*—current assets less current liabilities.

AUTHORITY NOTE: Promulgated in accordance with R.S. 23:1291, R.S. 23:1168, and Act 938 of 1988 Regular Session.

HISTORICAL NOTE: Promulgated by the Department of Employment and Training, Office of Workers' Compensation, LR 17:960 (October 1991).

#### **§1707. Conditions for Obtaining Certificate of Self-Insurance**

A. The director shall prescribe aggregate and specific excess insurance coverage and/or surety bonds or the deposit of other security as a condition of obtaining a certificate of self-insurance.

AUTHORITY NOTE: Promulgated in accordance with R.S. 23:1291, R.S. 23:1168, and Act 938 of 1988 Regular Session.

HISTORICAL NOTE: Promulgated by the Department of Employment and Training, Office of Workers' Compensation, LR 17:960 (October 1991).

#### **§1709. Acceptable Securities or Surety**

A. The securities acceptable to the Office of Workers' Compensation Administration as a security deposit shall be U.S. Government Bonds; irrevocable letters of credit issued by a federal or state bank pre-approved by the office of Workers' Compensation; Surety Bonds in a form prescribed by the Office which are issued by any corporate surety which meets the qualifications prescribed in §1709.B; and other forms of security deemed acceptable by the director of the Office of Workers' Compensation. Self-insurers must have all funded securities made payable to the Office of Workers' Compensation.

B. Any corporate surety, to be eligible for writing self-insurers' bonds in the state of Louisiana, shall be an admitted or approved carrier by the insurance commissioner of the state of Louisiana to transact such a business in the state, shall have its latest financial statement on file with the insurance commissioner and the Office of Workers' Compensation Administration; and shall at all times show assets, including surplus to policyholders, at least equal to the latest Insurance Commission requirements for admission of a new company to do business in the state. The policyholders and financial ratings, as shown in the most current issue of Best's Key Rating Guide, Property-Casualty, shall not be less than "B" and "IV," respectively. In the event a company is not rated by Best's, a corporate surety may be approved at the discretion of the office.

C. All such securities shall be filed with the Office of Workers' Compensation for deposit under custody receipt. The office shall be authorized to sell and/or collect, in the case of default of the employer or group, such amount thereof as shall yield sufficient funds to pay compensation liabilities. The office shall likewise be authorized to bring suit upon any surety bond so posted, to procure prompt payment of compensation liabilities. Interest accruing on any negotiable securities so deposited shall be collected and transmitted to the depositor, provided he is not in default in the payment of compensation or the annual premium tax. All deposits shall remain in the custody of the office until such time as the workers' compensation claims, which the deposits secure, have been fully satisfied.

D. Any securities held by the office may be exchanged or replaced by the depositor with other securities of like nature and amount. Any surety bond may be exchanged or replaced with another surety bond, provided the required 30 days notice of termination of liability is given to the office. Whenever an employer discontinues business in the state or desires to terminate his status as a self-insurer, or desires to replace securities with a surety bond, he shall so notify the office and may recover the securities deposited with the office upon posting in lieu thereof a special release bond issued by a corporate surety in an amount equal to the total value of such securities. The special release bond shall cover all existing liabilities under the Workers' Compensation Act and shall remain in force in accordance with the prescriptive and preemptive period provided at R.S. 23:1209, and until such time, to be determined by the office, that all obligations under the Act have fully discharged.



AUTHORITY NOTE: Promulgated in accordance with R.S. 23:1168 of Act 938 of 1988 Regular Session.

HISTORICAL NOTE: Promulgated by the Department of Employment and Training, Office of Workers' Compensation, LR 17:961 (October 1991).

### §1711. Filing of Reports—Penalties

A. Each individual self-insurer shall file annual statements of financial condition with the Office of Workers' Compensation in a form acceptable to the Office of Workers' Compensation on or before May 1 of each year, except that fiscal year end filers shall file annual statements of financial condition four months after fiscal year end. These statements must be prepared by a certified public accountant and must be certified audits, except that an individual self-insurer may be allowed to submit another type of statement acceptable to the Office of Workers' Compensation. An additional security deposit or surety bond may be required in the absence of a certified audit.

B. Summary loss data will be filed with the Office of Workers' Compensation by each individual self-insurer on or before February 1 of each year. This report will include but not be limited to the name of the employer, name of the injured employee, claim number, date of accident, nature of injury, amounts paid on the claim for indemnity or medical and outstanding reserves, if any. This report will cover all incurred losses for the prior year as well as any pending claims where any type payment is made or reserve is pending.

C. In addition to the above required annual reports, the Office of Workers' Compensation may require interim financial statements, summary loss data, payroll audits, or such other reports or statements upon reasonable notice.

D. This rule places the responsibility on the employers, groups and service companies to perform their prescribed duties and responsibilities without prompting from the office. Failure or refusal of any self-insurer to file the required report with the office within the prescribed time period shall subject the self-insurer to a civil penalty in such amount as the office may prescribe, not to exceed \$100 per infraction per day, and may be sufficient cause for the revocation of the self-insurer privilege. Failure to pay such penalty within 30 days of the notification may be considered additional cause for revocation of the self-insurer privilege.

AUTHORITY NOTE: Promulgated in accordance with R.S. 23:1168 of Act 938 of 1988 Regular Session.

HISTORICAL NOTE: Promulgated by the Department of Employment and Training, Office of Workers' Compensation, LR 17:961 (October 1991).

### §1713. Contract of Excess Insurance

A. Aggregate and specific excess insurance with liability limits and retention amounts acceptable to the Office of Workers' Compensation shall be required as a condition of approval of any individual self-insurer as hereinafter provided.

1. The retention of specific excess policies shall be no more than \$250,000 or one percent of the self-insurer's net worth, whichever is greater. The maximum retention so

calculated shall be rounded to the nearest \$50,000. Acceptable retention levels, subject to the above maximum, shall be determined by the office for each self-insurer. Such acceptable retention shall be based on an evaluation of the self-insurer's financial condition and exposure to loss.

2. In cases where the upper limit of a corporation's excess insurance is not statutory, the Office of Workers' Compensation will require that the amount be at least the greater of the average incurred workers' compensation losses for the last three years or \$5,000,000.

B. No contract or policy of excess insurance shall be recognized by the office in considering the ability of an applicant to fulfill its financial obligation under the Workers' Compensation Act unless such contract or policy:

1. is issued by a recognized, admitted or approved casualty insurance company with a financial rating as shown in the most current issue of Best's Key Rating Guide, Property-Casualty of not less than "B" and "IV;"

2. is not cancelable except upon 20 days written notice by registered or certified mail to the other party to the policy and the Office of Workers' Compensation. The required notice is 10 days if the cancellation is for non-payment of policy premium; and

3. is renewable at the expiration of the policy period unless written notice by registered or certified mail is given to the other party to the policy and the Office of Workers' Compensation, 20 days prior to such expiration, by the party desiring to cancel or not to renew the policy. The required notice or nonrenewal is 10 days if the nonrenewal is for nonpayment of policy premium.

C. Additionally, a contract or policy of excess insurance containing any commutation clause shall only be recognized by the office in considering the ability of an applicant to fulfill its financial obligation under the Workers' Compensation Act where the office is satisfied that sufficient security is provided to assure future payments of compensation to employee(s) entitled thereto.

AUTHORITY NOTE: Promulgated in accordance with R.S. 23:1168 of Act 938 of 1988 Regular Session.

HISTORICAL NOTE: Promulgated by the Department of Employment and Training, Office of Workers' Compensation, LR 17:961 (October 1991).

### §1715. Servicing for Self-Insurer; Qualifications for Service Companies

A. Each individual self-insurer, as a condition of approval to self-insure, shall be required to provide proof of compliance with the provisions of this Section as follows.

1. It shall be the sole responsibility of each individual self-insurer to provide for qualified persons to service its program in the areas of claims adjusting, underwriting, safety engineering and loss control. Should the individual self-insurer be unable or unwilling to provide any or all of these services through the use of its own employees, then it shall contract with outside agencies with established

qualifications, as evidenced by their official certificates of approval issued by this office, to provide these services.

2. In the case where an individual self-insurer elects to contract with an approved service company, the Office of Workers' Compensation may, at its discretion, choose to use the service company as an intermediary in its dealings with the employer. In the case where no service company is used, the office will deal with the employer only.

B. Any firm desiring to become qualified as a service company for individual self-insurers shall make application to the office on such forms as may be prescribed and the application must be approved before any contract for servicing shall be recognized as fulfilling §1715.A.

C. Any firm making application to qualify as a service company shall provide proof that it meets the following conditions before approval may be granted.

1. The owners of the firm, including members of a co-partnership, and the officers of the corporation, shall be persons of good moral character with reputations for honesty and fair dealings.

2. The firm has a sufficient number of experienced and qualified claims personnel, including at least one resident adjuster with check or draft authority.

3. The firm has a sufficient number of experienced and qualified personnel in the areas of loss control and safety engineering.

4. The firm has a sufficient number of experienced and qualified personnel in the area of underwriting. In this context, underwriting includes, but is not limited to, the overall planning and coordinating of a self-insurer program, the ability to advise or assist in the procurement of bonds and excess insurance, the ability to provide summary data regarding the self-insurer's costs of accidents, including the frequency and distribution by type and cause, and the skill to make recommendations to the self-insurer regarding the correction of any deficiencies that arise in the self-insurer program.

5. The application for the privilege of being a service company, as defined herein, shall be accompanied by a remittance in the amount of \$200, payable to the Office of Workers' Compensation. This fee will not be refunded, regardless of the disposition of the application.

D. In support of its application the firm shall submit summary information concerning its organization and résumés on all employees with administrative or professional capacity sufficient to establish compliance with §1715.C.

E. Upon compliance to the satisfaction of the office with the above provisions, a certificate of approval as a recognized and authorized service organization shall be issued to the applicant. Failure to comply with any of the foregoing rules or any order of the office within the time prescribed shall be considered good cause for withdrawal of the certificate of approval. The office shall give prior written notice of such withdrawal. The service company shall have

15 days from the date of mailing to request a hearing. Failure to request a hearing within the time prescribed shall result in the withdrawal becoming effective 30 days from the date of mailing of the original notice. In no event shall the withdrawal of the certificate of approval be effective prior to the date that the hearing on the question is scheduled. Such notice shall be served personally or by certified or registered mail upon all interested parties.

F. Each service company shall file immediately upon entering into a contract or agreement for servicing, notice of this contract or agreement with the Office of Workers' Compensation Administration. It shall be the responsibility of the individual self-insurer to obtain the written permission of the Office of Workers' Compensation Administration before changing its method of fulfilling its servicing requirements from those which were previously approved by the office.

AUTHORITY NOTE: Promulgated in accordance with R.S. 23:1168 of Act 938 of 1988 Regular Session.

HISTORICAL NOTE: Promulgated by the Department of Employment and Training, Office of Workers' Compensation, LR 17:962 (October 1991).

#### **§1717. Revocation or Termination of the Self-Insurer Privilege**

A. Failure to comply with any of the rules or with any order of the Office of Workers' Compensation Administration within the time prescribed may be considered good cause for revocation or termination of self-insurer privilege, within the meaning of Louisiana Statutes. Noncompliance with the provisions of the Workers' Compensation Act, in particular those relating to time and method of compensation payments, the furnishing of medical treatment and filing of accident and compensation reports and failure to pay any assessment, may likewise be deemed good cause. The office shall give written notice of such revocation or termination to the employer and/or his agent(s). The employer shall have 15 days from the date of mailing of the notice to request a hearing on the revocation or termination. Failure to request a hearing within the time prescribed shall result in the revocation or termination becoming effective 30 days from the date of mailing of the original notice. In no event shall any revocation or termination become effective prior to the date that a hearing on the question is scheduled. Such notice shall be served personally or by registered mail upon all interested parties.

B. It will be necessary for a self-insurer to notify the office if the status of the self-insurer is materially changed (individual ownership to partnership or to corporation, merger, etc.), at which time the new entity shall be required to qualify. In the event there is a change in majority ownership of a self-insurer, the self-insurer privilege granted to an individual self-insurer shall be at the discretion of the office.

AUTHORITY NOTE: Promulgated in accordance with R.S. 23:1168 of Act 938 of 1988 Regular Session.

HISTORICAL NOTE: Promulgated by the Department of Employment and Training, Office of Workers' Compensation, LR 17:962 (October 1991).

**§1719. Enforcement by Office of Workers' Compensation of Order of Compliance; Order of Denial; or Order of Termination of Self-Insured Status**

A. If the Office of Workers' Compensation has probable cause to believe that an order denying or terminating self-insurer status is being violated or that an employer who is approved or has been previously approved as a self-insurer is liquidating or may be about to liquidate and distribute its assets to its stockholders or to its members without providing for its obligation as a self-insurer to pay or arrange for the payment of compensation and benefits as prescribed for in the Act, the office may cause an action to be filed in the Court of East Baton Rouge Parish or in the parish in which such person does business to enjoin and restrain such person from engaging in such method, act or practice; in addition to the other penalties it may assess according to law.

AUTHORITY NOTE: Promulgated in accordance with R.S. 23:1168, 1169, 1170 and Act 938 of 1988 Regular Session.

HISTORICAL NOTE: Promulgated by the Department of Employment and Training, Office of Workers' Compensation, LR 17:963 (October 1991).

**§1721. Tenure of Authority**

A. Certificates of authority granting the privilege of being a self-insurer for workers' compensation purposes shall expire on July 1 of each year or two months after the annual report is due for fiscal year end filers. At the time of renewal, the self-insurer must furnish or have on file with the office, an acceptable financial statement for its current fiscal year and must fully comply with the law and the rules of this office. Certificates of approval for service companies must be renewed on an annual basis. Any information submitted by an employer in its application to become a self-insurer, or in its request for renewal of that authority, will be treated with strict confidence by the office. Any information submitted by a service company in its application for approval or in its request for renewal of that approval will be treated with strict confidence by the office except that the name, address, and status of an employer that is self-insured may be communicated effective September 1, 1991 pursuant to amendments to R.S. 23:1168(A)(4).

AUTHORITY NOTE: Promulgated in accordance with R.S. 23:1168 of Act 938 of 1988 Regular Session.

HISTORICAL NOTE: Promulgated by the Department of Employment and Training, Office of Workers' Compensation, LR 17:963 (October 1991).

**§1723. Individual Self-Insurer—Application**

A. Each employer desiring to become a self-insurer individually, as contemplated by Louisiana Statutes, shall make application to the office for such privilege on a form prescribed by the office, and this application shall be filed with the office at least 60 days prior to the desired effective date. The application shall contain answers to all questions propounded and shall be under oath.

B. Before considering the application, the office will require:

1. financial statement of a current date showing a net worth of not less than \$750,000 and a current ratio of more than 1.5 to 1 and a working capital of an amount establishing strength and liquidity of the business to pay normal compensation promptly. A surety bond as provided in §1725 shall be considered to be part of the net worth of the employer. However, companies qualified to be self-insured prior to the implementation of these rules who do not meet the requirement of a net worth of \$750,000 may nonetheless qualify for continued certification upon a showing that they meet all other requirements of these rules and that they have been continually operating as an approved self-insurer. The requirement for more than 1.5 to 1 current ratio may be waived in the case of a public utility or in those instances where generally recognized accounting principles peculiar to a particular industry make this requirement unreasonable. In no event shall the net worth be less than three times the annual loss fund, or in the event that aggregate excess insurance is not maintained, then the net worth shall be at least three times the self-insurer's annual standard premium. Financial statements dated six months or more prior to the date of application must be accompanied by an affidavit stating that there has been no material lessening of net worth nor significant deterioration of current ratio since the date of the statement;

2. an employer going through or recently acquired through a highly leveraged buyout is not eligible to self-insure until the company has a well established and acceptable financial capacity. Judgment of the company's financial capacity will be based upon financial ratio analysis. This type of company must operate on an insured basis until the financial status is fully known;

3. in considering the financial strength and liquidity of the business to pay normal compensation claims, the office will take into consideration contracts or policies of excess insurance in accordance with §1711;

4. the determination of a company's financial strength will also be based upon a financial ratio analysis and the trends in operating and net income. A number of successive years operating net losses experienced by a company may cause the Office of Workers' Compensation to deem that company unable to assume the responsibility of self-insuring;

5. in addition, a company must have been in business for at least three years unless it is part of an established operation that is able to guarantee the financial stability of the concern;

6. each employer shall execute and file with the office an agreement, which shall be part of his application, whereby he agrees:

a. to fully discharge by cash payment all amounts required to be paid by the provisions of the Act; and

b. to deposit with the office acceptable securities or corporate surety bond to secure guarantee of payment of compensation liabilities;

7. each Individual self-insurer shall satisfy the office that it has complied with the provisions of §1713.A. before approval for self-insurer status may be granted by the office. In addition, the office may require periodic proof that the self-insurer is complying with these standards on a continuing basis;

8. the application for the privilege or the renewal of the privilege of being a self-insurer shall be accompanied by a remittance in the amount of \$100, payable to the Office of Workers' Compensation. This fee will not be refunded, regardless of the disposition of the application;

9. an investigation and study of the financial and other capabilities of the individual applicant to meet its obligation under the Act will be conducted by the self-insurer department of the office. The administrator of the self-insurer department of the office will submit an evaluation report to the office, after which formal approval for self-insurer status may be granted by the office.

AUTHORITY NOTE: Promulgated in accordance with R.S. 23:1168.

HISTORICAL NOTE: Promulgated by the Department of Employment and Training, Office of Workers' Compensation, LR 17:963 (October 1991), amended by the Department of Labor, Office of Workers' Compensation, LR 23:868 (July 1997).

#### §1725. Security Requirements

A. Pursuant to R.S. 23:1168, each individually self-insured employer shall deposit with the office acceptable securities or post a surety bond issued by a corporate surety authorized to do business in the state of Louisiana and qualified as herein provided or make such other provision as may be approved by the office in such amount as may be determined by the office in accordance with the following rules.

1. In every case where an application is favorably considered, the office will then decide the amount of acceptable securities or surety bond which will be required; provided, however, that in no case shall the amount of securities or surety bond be less than the greater of:

- a. \$100,000;
- b. the average workers' compensation losses incurred over the most recent three year period multiplied by 110 percent; or
- c. the total amount of unpaid workers' compensation reserves at the time of application multiplied by 110 percent.

2. A majority-owned subsidiary of a parent company, duly admitted as a self-insurer, may not be required to post securities or surety bond, provided the parent company by resolution guarantees payment of the liabilities of the subsidiary.

3. The minimum excess insurance requirements that an individually self-insured employer shall maintain shall be determined by the office.

AUTHORITY NOTE: Promulgated in accordance with R.S. 23:1168 of Act 938 of 1988 Regular Session.

HISTORICAL NOTE: Promulgated by the Department of Employment and Training, Office of Workers' Compensation, LR 17:964 (October 1991).

#### §1727. Forfeiture of Security

A. An injured worker or group of injured workers can apply to the director for the payment of benefits pursuant to R.S. 23:1168.D if a self-insured employer has failed to pay benefits for undisputed claims.

B. Upon default the office shall deposit the proceeds from the security or the bond into an interest bearing account. The interest derived therefrom shall be used to offset the administration of claims. The office may thereafter contract for the administration of claims from the account.

C. In the event the director pursuant to R.S. 23:1168.D provides for pro rata distribution of security proceeds to claimants or issues an order or decision which may be adverse to a claimant, he may within 60 days of the order or decision appeal to the district courts of this state.

AUTHORITY NOTE: Promulgated in accordance with R.S. 23:1168 of Act 938 of 1988 Regular Session.

HISTORICAL NOTE: Promulgated by the Department of Employment and Training, Office of Workers' Compensation, LR 17:964 (October 1991).

#### §1729. Financial Classes, Security Amounts, and Waiver of Security

A. Each self-insurer will be classified according to its net worth as shown on its most recent year-ended financial statement submitted to our office. The following classifications will be established and known as Financial Classes (FC).

1. An employer whose net worth is greater than or equal to \$750,000 but less than \$5,000,000 shall be in Financial Class I (FC I).

2. An employer whose net worth is greater than or equal to \$5,000,000 but is less than \$50,000,000 shall be in Financial Class II (FC II).

3. An employer whose net worth is greater than or equal to \$50,000,000 but less than \$250,000,000 shall be in Financial Class III (FC III).

4. An employer whose net worth is greater than or equal to \$250,000,000 shall be in Financial Class IV (FC IV).

B. The bond or security in FC IV, deposit requirement of a self-insurer may only be waived as follows:

1. in FC IV, if a satisfactory certified audit is submitted and the debt/equity ratio that is below 3:1; or

2. if applicant is a municipality or other political subdivision which has maintained a bond rating of not less than Baa (Moody's) on all outstanding bond issues and continuously maintained an unrestricted fund balance of not less than \$5,000,000.

C. The security required by the Office of Workers' Compensation will be the greater of \$100,000 or the average

of the most recent three years of workers' compensation losses incurred. In no event shall this calculated amount be less than the workers' compensation outstanding reserves. In the event that the open workers' compensation reserves are greater than the average workers' compensation losses incurred, the amount of the security required will be the amount of the open reserves.

**AUTHORITY NOTE:** Promulgated in accordance with R.S. 23:1168 of Act 938 of 1988 Regular Session.

**HISTORICAL NOTE:** Promulgated by the Department of Employment and Training, Office of Workers' Compensation, LR 17:964 (October 1991).

### **§1731. Appeals**

A. A request for hearing pursuant to §1715.E or §1717.A or an application for appeal from an adverse discretionary decision made by the office may be made to the director of the Office of Workers' Compensation by an applicant, self-insurer or service company.

B. Requests for hearing or applications for appeals must be in writing and filed within 30 days of the notice of the decision or, if no notice is given, within 30 days from becoming aware of or the date the aggrieved party should have been aware of the adverse decision. The appeal must be addressed to the director of the Office of Workers' Compensation and mailed to Box 94040, Baton Rouge, LA 70804, or hand delivered to the office at 1001 North Twenty-Third Street, Baton Rouge, LA. Appeals may not be supplemented or amended after the lapse of 30 days. An appellant has the right to file a written appeal or have the appeal heard orally. Requests for an oral hearing must be made within the 30-day time period to file the appeal.

C. If no request for an oral hearing is made, then the appellant may submit documentation and/or written memorandum to support the appeal at least 15 days prior to the review of the appeal. Appellant will be notified at least 30 days prior to the date of the review by the director or the appeal committee appointed by the director. The director or the appeal committee will review all the evidence submitted and render a decision.

D. If the appellant requests an oral hearing, then appellant will be given at least 30 days prior notice of the hearing. The director may appoint a hearing officer to hear the appeal of the appellant. All hearings shall be conducted in accordance with the provisions of the Administrative Procedure Act, R.S. 49:955 et seq. On the day of the oral hearing appellant and appellee shall be prepared to start the hearing at the time specified in the notice of hearing. The hearing may be continued for good cause provided a written request for extension is received at the Office of Workers' Compensation at least seven days prior to the date of the hearing.

E. If after the review of the appeal committee or after a hearing held before the hearing officer or the director a decision adverse to the appellant is made, then appellant within 30 days of the date the order or decision is signed may appeal this administrative decision to the district courts of this state.

**AUTHORITY NOTE:** Promulgated in accordance with R.S. 23:1168 of Act 938 of 1988 Regular Session.

**HISTORICAL NOTE:** Promulgated by the Department of Employment and Training, Office of Workers' Compensation, LR 17:965 (October 1991).

### **§1733. Annual Reports**

A. All carriers writing workers' compensation insurance and all self-insured employers shall submit to the office, by April 30 of each year, an annual report on Form LDOL-WC-1000 showing the amount of workers' compensation benefits paid in the previous calendar year.

**AUTHORITY NOTE:** Promulgated in accordance with R.S. 23:1291.

**HISTORICAL NOTE:** Promulgated by the Department of Labor, Office of Workers' Compensation, LR 22:222 (March 1996).

### **§1735. Assessments**

A. The annual report will be used by the director in determining an assessment for the administration of workers' compensation. The assessment shall be paid into the Office of Workers' Compensation Administrative Fund within 30 days from the date notice is served upon such carrier. If such amount is not paid within such period there may be assessed, for each 30 days the amount assessed remains unpaid, a civil penalty equal to 20 percent of the amount unpaid, which shall be due and collected at the same time as the unpaid part of the amount assessed.

**AUTHORITY NOTE:** Promulgated in accordance with R.S. 23:1291.

**HISTORICAL NOTE:** Promulgated by the Department of Labor, Office of Workers' Compensation, LR 22:222 (March 1996).

### **§1737. Compliance Penalty**

A. If any carrier fails to pay the amount assessed against it within 60 days from the time such notice is served upon it, the commissioner of insurance, upon being advised by the director, may suspend or revoke the authorization to insure compensation in accordance with the procedures of the insurance code.

**AUTHORITY NOTE:** Promulgated in accordance with R.S. 23:1291.

**HISTORICAL NOTE:** Promulgated by the Department of Labor, Office of Workers' Compensation, LR 22:222 (March 1996).

## **Chapter 19. Fraud**

### **§1901. Forms**

A. The following forms are prescribed for use pursuant to R.S. 23:1208:

1. LDOL-WC-1025 Employee's and Employer's Certificate of Compliance; and
2. LDOL-WC-1026 Employee's Quarterly Report of Earnings.

**AUTHORITY NOTE:** Promulgated in accordance with R.S. 23:1208 and 23:1291.

**HISTORICAL NOTE:** Promulgated by the Department of Employment and Training, Office of Workers' Compensation, LR 17:359 (April 1991), amended by the Department of Labor, Office of Workers' Compensation, LR 22:222 (March 1996).

**§1903. Certification; Report**

A. For an accident occurring on or after April 1, 1996, the employee and employer shall certify their compliance with the Louisiana Workers' Compensation Act by filing with their insurer Form LDOL-WC-1025, Employee's and Employer's Certificate of Compliance.

B.1. Whenever an employee receives workers' compensation indemnity disability benefits for more than 30 days, the employee shall report his other earnings to his employer's insurer quarterly on Form LDOL-WC-1026, Employee's Quarterly Report of Earnings.

2. The requirements of §1903.B.1 are waived whenever an employee has timely filed all necessary LDOL-WC-1020 Forms, or only has received medical benefits.

AUTHORITY NOTE: Promulgated in accordance with R.S. 23:1208 and 23:1291.

HISTORICAL NOTE: Promulgated by the Department of Employment and Training, Office of Workers' Compensation, LR 17:359 (April 1991), amended by the Department of Labor, Office of Workers' Compensation, LR 22:222 (March 1996).

**§1905. Penalty; Hearing; Appeal**

A. Any person violating the provisions of R.S. 23:1208 may be assessed civil penalties by the director of not less than \$500 nor more than \$5000.

B. A person may appeal any penalty imposed pursuant to this rule by filing Form LDOL-WC-1008, Disputed Claim for Compensation, in the district where the person is located or in Baton Rouge, LA. All such appeals shall be de novo. Any penalty imposed pursuant to this rule becomes final and may be pursued for collection unless such an appeal is filed within 30 days of the notice of penalty.

AUTHORITY NOTE: Promulgated in accordance with R.S. 23:1208 and 23:1291(1)(5).

HISTORICAL NOTE: Promulgated by the Department of Employment and Training, Office of Workers' Compensation, LR 17:359 (April 1991), amended by the Department of Labor, Office of Workers' Compensation, LR 22:223 (March 1996), LR 22:993 (October 1996).

**§1907. Notice of Penalty; Filing**

A. The director shall notify the employee and employer of any civil penalty imposed for violation of R.S. 23:1208. In addition, the director shall file the notice of penalty in the record of the disputed claim for benefits.

AUTHORITY NOTE: Promulgated in accordance with R.S. 23:1208 and 23:1291.

HISTORICAL NOTE: Promulgated by the Department of Employment and Training, Office of Workers' Compensation, LR 17:359 (April 1991), amended by the Department of Labor, Office of Workers' Compensation, LR 22:223 (March 1996).

**Title 40**  
**LABOR AND EMPLOYMENT**  
**Part I. Workers' Compensation Administration**  
**Subpart 2. Medical Guidelines**

**Chapter 20. Spine Medical Treatment Guidelines**

**Subchapter A. Cervical Spine Injury**

Editor's Note: Form LWC-WC 1009, Disputed Claim for Medical Treatment has been moved to §2328 of this Part.

**§2001. Introduction**

A. This document has been prepared by the Louisiana Workforce Commission, Office of Workers' Compensation (OWCA) and should be interpreted within the context of guidelines for physicians/providers treating individuals qualifying under Louisiana's Workers' Compensation Act as injured workers with cervical spine injuries. Although the primary purpose of this document is advisory and educational, these guidelines are enforceable under the Louisiana Workers Compensation Act. All medical care, services, and treatment owed by the employer to the employee in accordance with the Louisiana Workers' Compensation Act shall mean care, services, and treatment in accordance with these guidelines. Medical care, services, and treatment that varies from these guidelines shall also be due by the employer when it is demonstrated to the medical director of the office by a preponderance of the scientific medical evidence, that a variance from these guidelines is reasonably required to cure or relieve the injured worker from the effects of the injury or occupational disease given the circumstances. Therefore, these guidelines are not relevant as evidence of a provider's legal standard of professional care. To properly utilize this document, the reader should not skip nor overlook any sections.

**AUTHORITY NOTE:** Promulgated in accordance with R.S. 23:1203.1.

**HISTORICAL NOTE:** Promulgated by the Louisiana Workforce Commission, Office of Workers Compensation Administration, LR 37:1631 (June 2011), amended by the Louisiana Workforce Commission, Office of Workers Compensation, LR 40:1119 (June 2014), LR 49:515 (March 2023).

**§2003. General Guideline Principles**

A. The principles summarized in this section are key to the intended implementation of all Office of Workers' Compensation medical treatment guidelines and critical to the reader's application of the guidelines in this document.

1. Application of Guidelines. The OWCA provides procedures to implement medical treatment guidelines and to foster communication to resolve disputes among the provider, payer, and patient through the Workers' Compensation Act.

2. Education. Education of the patient and family, as well as the employer, insurer, policy makers and the community should be the primary emphasis in the treatment of workers' compensation injuries. Currently, practitioners often think of education last, after medications, manual therapy, and surgery. Practitioners must develop and implement strategies to educate patients, employers, insurance systems, policy makers, and the community as a whole. An education-based paradigm should always start with inexpensive communication providing reassuring and evidence-based information to the patient. More in-depth education is currently a component of treatment regimens which employ functional, restorative, preventive and rehabilitative programs. No treatment plan is complete without addressing issues of individual and/or group patient education as a means of facilitating self-management of symptoms and prevention. Facilitation through language interpretation, when necessary, is a priority and part of the medical care treatment protocol.

3. Informed Decision Making. Providers should implement informed decision making as a crucial element of a successful treatment plan. Patients, with the assistance of their health care practitioner, should identify their personal and professional functional goals of treatment at the first visit. Progress towards the individual's identified functional goals should be addressed by all members of the health care team at subsequent visits and throughout the established treatment plan. Nurse case managers, physical therapists, and other members of the health care team play an integral role in informed decision-making and achievement of functional goals. Patient education and informed decision-making should facilitate self-management of symptoms and prevention of further injury.

4. Treatment Parameter Duration. Time frames for specific interventions commence once treatments have been initiated, not on the date of injury. Obviously, duration will be impacted by patient adherence, as well as availability of services. Clinical judgment may substantiate the need to accelerate or decelerate the time frames discussed in this document. Such deviation shall be in accordance with La. R.S. 23:1203.1.

5. Active Interventions. Emphasizing patient responsibility, such as therapeutic exercise and/or functional treatment, are generally emphasized over passive modalities, especially as treatment progresses. Generally, passive interventions are viewed as a means to facilitate progress in an active rehabilitation program with concomitant attainment of objective functional gains.

6. Active Therapeutic Exercise Program. Exercise program goals should incorporate patient strength, endurance, flexibility, coordination, and education. This includes functional application in vocational or community settings.

7. Positive Patient Response. Positive results are defined primarily as functional gains that can be objectively measured.

a. Objective functional gains include, but are not limited to, positional tolerances, range-of-motion (ROM), strength, and endurance, activities of daily living, ability to function at work, cognition, psychological behavior, and efficiency/velocity measures that can be quantified. Subjective reports of pain and function should be considered and given relative weight when the pain has anatomic and physiologic correlation. Anatomic correlation must be based on objective findings.

8. Re-Evaluation of Treatment within Four Weeks. If a given treatment or modality is not producing positive results within four weeks, treatment should be either modified or discontinued. Reconsideration of diagnosis should also occur in the event of poor response to a seemingly rational intervention.

9. Surgical Interventions. Surgery should be contemplated within the context of expected improvement of functional outcome and not purely for the purpose of pain relief. The concept of "cure" with respect to surgical treatment by itself is generally a misnomer. All operative interventions must be based upon positive correlation of clinical findings, clinical course, and diagnostic tests. A comprehensive assimilation of these factors must lead to a specific diagnosis with positive identification of pathologic conditions. The decision and recommendation for operative treatment, and the appropriate informed consent should be made by the operating surgeon. Prior to surgical intervention, the patient and treating physician should identify functional operative goals and the likelihood of achieving improved ability to perform activities of daily living or work activities and the patient should agree to comply with the pre- and post-operative treatment plan and home exercise requirements. The patient should understand the length of partial and full disability expected post-operatively.

10. Pharmacy-Louisiana Law and Regulation. All prescribing will be done in accordance with the laws of the state of Louisiana as they pertain respectively to each individual licensee, including, but not limited to: Louisiana State Board of Medical Examiners regulations governing medications used in the treatment of non-cancer-related chronic or intractable pain; Louisiana Board of Pharmacy Prescription Monitoring Program; Louisiana Department of Health and Hospitals licensing and certification standards for pain management clinics; other laws and regulations affecting the prescribing and dispensing of medications in the state of Louisiana.

11. Six Month Time Frame. Injuries resulting in temporary total disability may require maintenance treatment and may not attain return to work in six months.

12. Return to Work. Return to work is therapeutic, assuming the work is not likely to aggravate the basic problem or increase long-term pain. An injured worker's return-to-work status shall not be the sole cause to deny reasonable and medically necessary treatment under these guidelines. Two good practices are: early contact with injured workers and provide modified work positions for short-term injuries. The practitioner must provide specific physical limitations and the patient should never be released to non-specific and vague descriptions such as "sedentary" or "light duty." The following physical limitations should be considered and modified as recommended: lifting, pushing, pulling, crouching, walking, using stairs, bending at the waist, awkward and/or sustained postures, tolerance for sitting or standing, hot and cold environments, data entry and other repetitive motion tasks, sustained grip, tool usage and vibration factors. Even if there is residual chronic pain, return-to-work is not necessarily contraindicated. The practitioner should understand all of the physical demands of the patient's job position before returning the patient to full duty and should request clarification of the patient's job duties. Clarification should be obtained from the employer or, if necessary, from including, but not limited to, occupational health nurse, physical therapist, occupational therapist, vocational rehabilitation specialist, chiropractor or another professional. American Medical Association clarifies "disability" as "activity limitations and/or participation restrictions in an individual with a health condition, disorder or disease" versus "impairment" as "a significant deviation, loss, or loss of use of any body structure or body function in an individual with a health condition, disorder or disease".

13. Delayed Recovery. Within the discretion of the treating physician, strongly consider a psychological evaluation, if not previously provided, as well as initiating interdisciplinary rehabilitation treatment and vocational goal setting, for those patients who are failing to make expected progress 6 to 12 weeks after initiation of treatment of an injury. The OWCA recognizes that 3 to 10 percent of all industrially injured patients will not recover within the timelines outlined in this document despite optimal care. Such individuals may require treatments beyond the limits discussed within this document, but such treatment requires clear documentation by the authorized treating practitioner focusing on objective functional gains afforded by further treatment and impact upon prognosis.

14. Guideline Recommendations and Inclusion of Medical Evidence. All recommendations are based on available evidence and/or consensus judgment. It is generally recognized that early reports of a positive treatment effect are frequently weakened or overturned by subsequent research. Per R.S. 1203.1, when interpreting medical evidence statements in the guideline, the following apply to the strength of recommendation.



Strong	Level 1 Evidence	We Recommend
Moderate	Level 2 and Level 3 Evidence	We Suggest
Weak	Level 4 Evidence	Treatment is an Option
Inconclusive	Evidence is Either Insufficient or Conflicting	

a. Consensus guidelines are generated by a professional organization that the guidelines are intended to serve. A committee of specialists and experts are selected by the organization to create an unbiased, vetted recommendation for the treatment of specific issues within the realm of their expertise. All recommendations in the guideline are considered to represent reasonable care in appropriately selected cases, regardless of the level of evidence or consensus statement attached to it. Those procedures considered inappropriate, unreasonable, or unnecessary are designated in the guideline as “not recommended.”

15. Treatment of Pre-Existing Conditions The conditions that preexisted the work injury/disease will need to be managed under two circumstances: (a) A pre-existing condition exacerbated by a work injury/disease should be treated until the patient has returned to their objectively verified prior level of functioning or Maximum Medical Improvement (MMI); and (b) A pre-existing condition not directly caused by a work injury/disease but which may prevent recovery from that injury should be treated until its objectively verified negative impact has been controlled. The focus of treatment should remain on the work injury/disease.

B. The remainder of this document should be interpreted within the parameters of these guideline principles that may lead to more optimal medical and functional outcomes for injured workers.

AUTHORITY NOTE: Promulgated in accordance with R.S. 23:1203.1.

HISTORICAL NOTE: Promulgated by the Louisiana Workforce Commission, Office of Workers Compensation Administration, LR 37:1631 (June 2011), amended by the Louisiana Workforce Commission, Office of Workers Compensation, LR 40:1119 (June 2014), LR 49:515 (March 2023).

### §2005. Initial Diagnostic Procedures

A. The OWCA recommends the following diagnostic procedures be considered, at least initially, the responsibility of the workers’ compensation carrier to ensure that an accurate diagnosis and treatment plan can be established. Standard procedures, that should be utilized when initially diagnosing a work-related cervical spine complaint, are listed below.

1. History-taking and physical examination (Hx and PE). These are generally accepted, well-established and widely used procedures that establish the foundation/basis for and dictate subsequent stages of diagnostic and therapeutic procedures. List of medications patient is taking should be included in every history, including over the counter medicines as well as supplements. When findings of clinical evaluations and those of other diagnostic procedures are not complementing each other, the objective clinical

findings should have preference. The medical records should reasonably document the following.

a. History of Present Injury. A detailed history, taken in temporal proximity to the time of injury, should primarily guide evaluation and treatment. The history should include pertinent, positive and negative information regarding the following:

i. Mechanism of Injury. This includes details of symptom onset and progression. The mechanism of injury should include a detailed description of the incident and the position of the body before, during, and at the end of the incident. Inclusion of normal work body postures, frequency during the workday and lifting/push/pull requirements, should be included in the absence of a known specific incident;

ii. Location of pain, nature of symptoms, and alleviating/exacerbating factors (e.g. sleep positions). Of particular importance, is whether raising the arm over the head alleviates radicular-type symptoms. The history should include both the primary and secondary complaints (e.g., primary neck pain, secondary arm pain, headaches, and shoulder girdle complaints). The use of a patient completed pain drawing, such as Visual Analog Scale (VAS) is highly recommended, especially during the first two weeks following injury to assure that all work related symptoms are being addressed;

iii. presence and distribution of upper and/or lower extremity numbness, paresthesias, or weakness, especially if precipitated by coughing or sneezing;

iv. alteration of bowel, bladder, or sexual function; and for female patients, alteration in their menstrual cycle;

v. any treatment for current injury and result; and

vi. ability to perform job duties and activities of daily living.

b. Past history:

i. past medical history includes neoplasm, arthritis, and diabetes;

ii. review of systems includes symptoms of rheumatologic, neurologic, endocrine, neoplastic, infectious, and other systemic diseases;

iii. smoking history;

iv. vocational and recreational pursuits;

v. history of depression, anxiety, or other psychiatric illness.

vi. The examiner will screen for concurrent emotional disorders/conditions and, when possible, other known psychosocial predictors of poor outcome;

vii. prior occupational and non-occupational injuries to the same area including specific prior treatment, chronic or recurrent symptoms, and any functional limitations; specific history regarding prior motor vehicle accidents may be helpful.

c. Physical Examination should include accepted tests and exam techniques applicable to the area being examined, including:

i. general and visual inspection, including posture, stance, balance and gait;

ii. palpation of spinous processes, facets, and muscles noting myofascial tightness, tenderness, and trigger points;

iii. cervical range-of-motion, quality of motion, and presence of muscle spasm. Motion evaluation of specific joints may be indicated. Range-of-motion should not be checked in acute trauma cases until fracture and instability have been ruled out on clinical examination, with or without radiographic evaluation;

iv. examination of thoracic spine;

v. motor and sensory examination of the upper muscle groups with specific nerve root focus, as well as sensation to light touch, pin prick, temperature, position and vibration. More than 2 cm difference in the circumferential measurements of the two upper extremities may indicate chronic muscle wasting; and

vi. Deep tendon reflexes. Asymmetry may indicate pathology. Inverted reflexes (e.g. arm flexion or triceps tap) may indicate nerve root or spinal cord pathology at the tested level. Pathologic reflexes include wrist, clonus, grasp reflex, and Hoffman's sign.

d. Relationship to Work: This includes a statement of the probability that the illness or injury is work-related. If further information is necessary to determine work relatedness, the physician should clearly state what additional diagnostic studies or job information is required.

e. Spinal Cord Evaluation: In cases where the mechanism of injury, history, or clinical presentation suggests a possible severe injury, additional evaluation is indicated. A full neurological examination for possible spinal cord injury may include:

i. Sharp and light touch, deep pressure, temperature, and proprioceptive sensory function;

ii. strength testing;

iii. anal sphincter tone and/or perianal sensation;

iv. presence of pathological reflexes of the upper and lower extremities; or

v. evidence of an Incomplete Spinal Cord Injury Syndrome:

(a). Anterior Cord Syndrome is characterized by the loss of motor function and perception of pain and temperature below the level of the lesion with preservation of touch, vibration, and proprioception. This is typically seen after a significant compressive or flexion injury. Emergent CT or MRI is necessary to look for a possible reversible compressive lesion requiring immediate surgical intervention. The prognosis for recovery is the worst of the incomplete syndromes.

(b). Brown-Sequard Syndrome is characterized by ipsilateral motor weakness and proprioceptive disturbance with contralateral alteration in pain and temperature perception below the level of the lesion. This is usually seen in cases of penetrating trauma or lateral mass fracture. Surgery is not specifically required, although debridement of the open wound may be.

(c). Central Cord Syndrome is characterized by sensory and motor disturbance of all limbs, often upper extremity more than lower, and loss of bowel and bladder function with preservation of perianal sensation. This is typically seen in elderly patients with a rigid spine following hyperextension injuries. Surgery is not usually required.

(d). Posterior Cord Syndrome, a rare condition, is characterized by loss of sensation below the level of the injury, but intact motor function.

vi. Spinal cord lesions should be classified according to the American Spine Injury Association (ASIA) impairment scale.

Asia Impairment Scale	
A=	Complete: No motor or sensory function is preserved in the sacral segments S4-S5
B=	Incomplete: Sensory but not motor function is preserved below the neurological level and includes the sacral segments S4-S5
C=	Incomplete: Motor function is preserved below the neurological level, and more than half of key muscles below the neurological level have a muscle grade less than 3
D=	Incomplete: Motor function is preserved below the neurological level, and at least half of key muscles below the neurological level have a grade of 3 or more
E=	Normal: motor and sensory function are normal

vii. A worksheet which details dermatomes and muscle testing required is available from ASIA.

f. Soft Tissue Injury Evaluation. Soft tissue injuries are traumatic injuries to the muscles, ligaments, tendons, and/or connective tissue. The most common mechanism is sudden hyperextension and/or hyperflexion of the neck. Acceleration/deceleration on the lateral plane may also result in one of these syndromes. A true isolated cervical strain is not associated with focal neurological symptoms. The signs and pathophysiology of these injuries are not well understood. Soft tissue injuries may include cervical strain, myofascial syndromes, somatic dysfunction, and fractures. The Quebec Classification is used to categorize soft tissue and more severe cervical injuries.

i. Grade I—neck complaints of pain, stiffness, or tenderness only, without physical signs. Lesion not serious enough to cause muscle spasm. Includes whiplash injury, minor cervical sprains, or strains.

ii. Grade II—neck complaints with musculoskeletal signs, such as limited range-of-motion. Includes muscle spasm related to soft tissue injury, whiplash, cervical sprain, and cervicgia with headaches, sprained cervical facet joints and ligaments.

iii. Grade III—neck complaints, such as limited range-of-motion, combined with neurologic signs. Includes

whiplash, cervicobrachialgia, herniated disc, cervicalgia with headaches.

iv. Grade IV—neck complaints with fracture or dislocation.

2. Radiographic imaging of the cervical spine is a generally accepted, well-established and widely used diagnostic procedure. Basic views are the anteroposterior (AP), lateral, right, and left obliques, swimmer's, and odontoid. CT scans may be necessary to visualize C7 and odontoid in some patients. Lateral flexion and extension views are done to evaluate instability but may have a limited role in the acute setting. MRI or CT is indicated when spinal cord injury is suspected. The mechanism of injury and specific indications for the imaging should be listed on the request form to aid the radiologist and x-ray technician. Alert, non-intoxicated patients, who have isolated cervical complaints without palpable midline cervical tenderness, neurologic findings, or other acute or distracting injuries elsewhere in the body, may not require imaging. The following suggested indications are:

a. history of significant trauma, especially high impact motor vehicle accident, rollover, ejection, bicycle, or recreational vehicle collision or fall from height greater than one meter;

b. age over 65 years;

c. suspicion of fracture, dislocation, instability, or neurologic deficit—Quebec Classification Grade III and IV;

d. unexplained or persistent cervical pain for at least 6 weeks or pain that is worse with rest;

e. localized pain, fever, constitutional symptoms, suspected tumor, history of cancer, or suspected systemic illness such as a rheumatic/rheumatoid disorder or endocrinopathy;

f. suspected lesion in the cervical spine due to systemic illness such as a rheumatic/rheumatoid disorder or endocrinopathy. Suspected lesions may require special views.

3. Laboratory Testing. Laboratory tests are generally accepted, well-established and widely used procedures. They are, however, rarely indicated at the time of initial evaluation, unless there is suspicion of systemic illness, infection, neoplasia, or underlying rheumatologic disorder, connective tissue disorder, or based on history and/or physical examination. Laboratory tests can provide useful diagnostic information. Tests include, but are not limited to:

a. complete blood count (CBC) with differential can detect infection, blood dyscrasias, and medication side effects;

b. erythrocyte sedimentation rate (ESR), rheumatoid factor (RF), antinuclear antigen (ANA), human leukocyte antigen (HLA), and C-reactive protein (CRP), can be used to detect evidence of a rheumatologic, infectious, or connective tissue disorder;

c. serum calcium, phosphorous, uric acid, alkaline phosphatase, and acid phosphatase can detect metabolic bone disease; and;

d. liver and kidney function may be performed for prolonged anti-inflammatory use or other medications requiring monitoring.

AUTHORITY NOTE: Promulgated in accordance with R.S. 23:1203.1.

HISTORICAL NOTE: Promulgated by the Louisiana Workforce Commission, Office of Workers Compensation Administration, LR 37:1632 (June 2011), amended by the Louisiana Workforce Commission, Office of Workers Compensation, LR 40:1120 (June 2014), LR 49:517 (March 2023).

### **§2007. Follow-Up Diagnostic Imaging and Testing Procedures**

A. One diagnostic imaging or testing procedure may provide the same or distinctive information as does another procedure. Therefore, prudent choice of a single diagnostic procedure, a complement of procedures, or a sequence of procedures will optimize diagnostic accuracy, and maximize cost effectiveness (by avoiding redundancy), and minimize potential adverse effects to patients. All imaging and testing procedures have a degree of specificity and sensitivity for various diagnoses. No isolated imaging test can assure a correct diagnosis.

B. Clinical information obtained by history taking and physical examination should form the basis for selecting an imaging procedure and interpreting its results. Clinical updates must demonstrate the patient's current status to document the need for diagnostic testing or additional treatment. A brief history, changes in clinical findings such as orthopedic and neurological tests, and measurements of function with emphasis on the current, specific physical limitations will be important when seeking approval of future care. The emphasis of the medical treatment schedule are that the determination of the need to continue treatment is based on functional improvement, and that the patient's ability (current capacity) to return to work is needed to assist in disability management.

C. Magnetic resonance imaging (MRI), myelography, or computed axial tomography (CT) scanning following myelography, and other imaging and testing procedures may provide useful information for many spinal disorders. When a diagnostic procedure, in conjunction with clinical information, provides sufficient information to establish an accurate diagnosis, the second diagnostic procedure will become a redundant procedure. At the same time, a subsequent diagnostic procedure can be a complementary diagnostic procedure if the first or preceding procedures, in conjunction with clinical information, cannot provide an accurate diagnosis. Usually, preference of a procedure over others depends upon availability, a patient's tolerance, and/or the treating practitioner's familiarity with the procedure.

1. Imaging studies are generally accepted, well-established and widely used diagnostic procedures. In the absence of myelopathy, progressive neurological changes or incapacitating pain, imaging usually is not appropriate until

conservative therapy has been tried and failed. Six to eight weeks of treatment are usually an adequate period of time before an imaging procedure is in order, but the clinician should use judgment in this regard. Early testing may be indicated for patients who demonstrate they cannot tolerate a trial of conservative therapy or who have a significant acute objective neurologic deficit that requires immediate imaging. When the findings of the diagnostic imaging and testing procedures are not consistent with the clinical examination, clinical findings should have preference. There is good evidence that in the over 40 asymptomatic population, the prevalence of disc degeneration is greater than 50 percent. Disc degeneration, seen as loss of signal intensity on MRI, may be due to age-related biochemical changes rather than structural deterioration, and may not have pathological significance. Disc bulging and posterior disc protrusion, while not rare, is more commonly symptomatic in the cervical spine than in the lumbar spine due to the smaller cervical spinal canal. Mild reduction in the cross-sectional area of the spinal cord may be seen without myelopathy in patients older than 40, therefore, clinical correlation is required. The studies below are listed in frequency of use, not importance.

a. Magnetic Resonance Imaging (MRI) is the imaging study of choice for most abnormalities of the cervical spine. MRI is useful in suspected nerve root compression, in myelopathy to evaluate the spinal cord and/or masses, infections such as epidural abscesses or disc space infection, bone marrow involvement by metastatic disease, and/or suspected disc herniation or cord contusion following severe neck injury. MRI should be performed immediately if there is a question of infection or metastatic disease with cord compression. MRI is contraindicated in patients with certain implanted devices.

i. In general, the high field, conventional, MRI provides better resolution. A lower field scan may be indicated when a patient cannot fit into a high field scanner or is too claustrophobic despite sedation. Inadequate resolution on the first scan may require a second MRI using a different technique. All questions in this regard should be discussed with the MRI center and/or radiologist. Repeat MRI testing may be needed in cases that involve a change in exam or symptoms or for contemplated surgical intervention.

ii. Specialized MRI Scans

(a). MRI with Three-Dimensional Reconstruction. On rare occasions, MRI with three-dimensional reconstruction views may be used as a pre-surgical diagnostic procedure to obtain accurate information of characteristics, location, and spatial relationships among soft tissue and bony structures;

(b). Dynamic-Kinetic MRI of the Spine. Dynamic-kinetic MRI of the spine uses an MRI unit configured with a top-front open design which enables upright, weight-bearing patient positioning in a variety of postures not obtainable with the recumbent images derived from conventional, closed unit MRI systems. Imaging can be obtained in flexion, extension, and rotation of the spine, as

well as in erect positioning. There is a theoretical advantage to imaging sequences obtained under more physiologic conditions than in the supine position. There is currently ongoing research to establish whether the theoretical advantages of positional and kinetic MRI result in improved sensitivity and specificity in detecting spine pathology. Currently it remains investigational, and is not recommended until the correlation with clinical syndromes is firmly established.

b. Computed axial tomography (CT) provides excellent visualization of bone and is used to further evaluate bony masses and suspected fractures not clearly identified on radiographic evaluation. It may sometimes be done as a complement to MRI scanning to better delineate bony osteophyte formation in the neural foramen. CT is usually utilized for suspected cervical spine fracture in a patient with negative plain films, or to further delineate a cervical fracture. CT scanning is also quite useful for congenital anomalies at the skull base and at the C1-2 levels. Plain CT scanning is poor for the C6-7 or C7-T1 levels because of shoulder artifact. Instrument-scatter reduction software provides better resolution when metallic artifact is of concern.

c. Post-Fusion Patients—monitoring of fusion can be done with initial x-rays within the first few weeks after surgery. Then, x-rays every three months up to a year. CT scan or X-rays can be done at one year to assess for fusion.

d. Myelography is the injection of radiopaque material into the spinal subarachnoid space, with x-rays then taken to define anatomy. It may be used as a diagnostic procedure to obtain accurate information of characteristics, location, and spatial relationships among soft tissue and bony structures. Myelography is an invasive procedure with complications including nausea, vomiting, headache, convulsion, arachnoiditis, CSF leakage, allergic reactions, bleeding, and infection. Therefore, myelography should only be considered when CT and MRI are unavailable, for morbidly obese patients or those who have undergone multiple operations, and when other tests prove non-diagnostic or fail to delineate pathology suspected by clinical presentation. The use of small needles and a less toxic, water-soluble, nonionic contrast is recommended.

e. CT myelogram provides more detailed information about relationships between neural elements and surrounding anatomy and is appropriate in patients with multiple prior operations or tumorous conditions.

f. Single Photon Emission Computerized Tomography (SPECT). A scanning technique which may be helpful to localize facet joint pathology and is useful in determining which patients are likely to have a response to facet injection. SPECT combines bone scans and CT scans in looking for facet joint pathology.

g. Bone scan (radioisotope bone scanning) is generally accepted, well-established and widely used. Bone scanning is more sensitive but less specific than MRI. <sup>99m</sup>Tc diphosphonate uptake reflects osteoblastic activity and may be useful in diagnosing metastatic/primary

bone tumors, stress fractures, osteomyelitis, and inflammatory lesions, but cannot distinguish between these entities. In the cervical spine, the usual indication is to evaluate for neoplastic conditions. Other indications include occult fracture or infection.

h. Other radioisotope scanning indium and gallium scans are generally accepted, well-established, and widely used procedures, usually to help diagnose lesions seen on other diagnostic imaging studies. <sup>67</sup>Gallium citrate scans are used to localize tumor, infection, and abscesses. <sup>111</sup>Indium-labeled leukocyte scanning is utilized for localizing infection or inflammation and is usually not used for the cervical spine.

i. Dynamic [digital] fluoroscopy dynamic [digital] fluoroscopy of the cervical spine measures the motion of intervertebral segments using a videofluoroscopy unit to capture images as the subject performs cervical flexion and extension, storing the anatomic motion of the spine in a computer. Dynamic Fluoroscopy may be used in state-designated trauma centers to evaluate the cervical spine. Its superiority over MRI has not been established. If performed, full visualization of the cervical spine (C1 - T1), in accordance with §2005.A.2. (Initial Diagnostic Procedures-Imaging), should be accomplished prior to the procedure. In the post-acute setting in some rare cases, Dynamic [Digital] Fluoroscopy may be used but is primarily an investigational tool and therefore, requires prior authorization in the post-acute setting. No studies have yet demonstrated predictive value in terms of standard operative and non-operative therapeutic outcomes.

2. Other Tests. The following diagnostic procedures are listed in alphabetical order, not by importance.

a. Electrodiagnostic Testing

i. Electromyography (EMG), and Nerve Conduction Studies. (NCS). These are generally accepted, well-established and widely used diagnostic procedures. EMG and NCS, when performed and interpreted by a trained physician/electrophysiologist, may be useful for patients with suspected neural involvement whose symptoms are persistent or unresponsive to initial conservative treatments. They are used to differentiate peripheral neural deficits from radicular and spinal cord neural deficits and to rule out concomitant myopathy. However, F-Wave Latencies are not diagnostic for radiculopathy.

ii. In general, EMG and NCS are complementary to imaging procedures such as CT, MRI, and/or myelography or diagnostic injection procedures. Electrodiagnostic studies may provide useful, correlative neuropathophysiological information that would be otherwise unobtainable from the radiologic studies discussed above. Repeat testing may be necessary in cases where follow-up of an initial abnormal test is required to determine efficacy of a treatment or evaluate changes in a patient.

iii. Portable Automated Electrodiagnostic Device (also known as Surface EMG) this is not a substitute for

conventional diagnostic testing in clinical decision-making and therefore, is not recommended.

iv. Somatosensory Evoked Potential (SSEP) is useful for the evaluation of myelopathy. It is not recommended to identify radiculopathy.

v. Current Perception Threshold Evaluation (CPT) may be useful as a screening tool, but its diagnostic efficacy in the evaluation of cervical spine pain has not been determined. Therefore, CPT is not recommended as a diagnostic tool

b. Injections—Diagnostic

i. Description Diagnostic cervical injections are generally accepted well-established procedures. These injections may be useful for localizing the source of pain, and may have added therapeutic value when combined with injection of therapeutic medication(s). Each diagnostic injection has inherent risks, and risk versus benefit should always be evaluated when considering injection therapy.

ii. Since these procedures are invasive, less invasive or non-invasive procedures should be considered first. Selection of patients, choice of procedure, and localization of the level for injection should be determined by clinical information indicating strong suspicion for pathologic condition(s) and the source of pain symptoms. Because injections are invasive with an inherent risk, the number of diagnostic procedures should be limited in any individual patient to those most likely to be primary pain generators. Patients should not receive all of the diagnostic blocks listed merely in an attempt to identify 100 percent of the pain generators.

iii. The interpretation of the test results are primarily based on functional change, symptom report, and pain response (via a recognized pain scale before and at an appropriate time after the injection). The diagnostic significance of the test result should be evaluated in conjunction with clinical information and the results of other diagnostic procedures. Injections with local anesthetics of differing duration may be used to support a diagnosis. In some cases, injections at multiple levels may be required to accurately diagnose cervical conditions. Refer to Injections – Therapeutic for information on specific injections.

(a). It is obligatory that sufficient data be accumulated by the examiner performing this procedure such that the diagnostic value of the procedure is evident to other reviewers. This entails, at a minimum, documentation of patient response immediately following the procedure with details of any symptoms with a response and the degree of response. Additionally, a log must be recorded as part of the medical records which documents response, if any, on an hourly basis for, at a minimum, the expected duration of local anesthetic phase of the procedure. Responses must be identified as to specific body part (e.g., neck, arm pain). The practitioner must identify the local anesthetic used and the expected duration of response for diagnostic purposes.

(b). Multiple injections provided at the same session without staging may seriously dilute the diagnostic

value of these procedures. Practitioners must carefully weigh the diagnostic value of the procedure against the possible therapeutic value.

iv. **Special Requirements for Diagnostic Injections.** Since multi-planar fluoroscopy during procedures is required to document technique and needle placement, an experienced physician should perform the procedure. Permanent images are required to verify needle placement. The subspecialty disciplines of the physicians performing the injections may be varied, including, but not limited to: anesthesiology, radiology, surgery, or physiatry. The practitioner should have completed fellowship training in pain medicine with interventional training, or its equivalent. They must also be knowledgeable in radiation safety.

v. **Complications.** General complications of diagnostic injections may include transient neurapraxia, nerve injury, infection, headache, vasovagal effects, as well as epidural hematoma, permanent neurologic damage, dural perforation and CSF leakage, and spinal meningial abscess. Severe complications are remote but can include spinal cord damage, quadriplegia, and/or death. Injections at a C2-C3 level frequently cause temporary neuritis with ataxia.

vi. **Contraindications**

(a). Absolute contraindications to diagnostic injections include:

- (i). bacterial infection—systemic or localized to region of injection;
- (ii). bleeding diatheses;
- (iii). hematological conditions; and
- (iv). possible pregnancy.

(b). Relative contraindications to diagnostic injections may include: allergy to contrast, poorly controlled diabetes mellitus, and hypertension.

(c). Drugs affecting coagulation may require restriction from use. Anti-platelet therapy and anti-coagulations should be addressed individually by a knowledgeable specialist. It is recommended to refer to the American Society of Regional Anesthesia for anticoagulation guidelines.

vii. **Specific Diagnostic Injections.** In general, relief should last for at least the duration of the local anesthetic used and should significantly relieve pain and result in functional improvement. Refer to “Injections- Therapeutic” for information on specific therapeutic injections.

(a). **Medial Branch Facet Blocks and Sacral Lateral Branch Blocks.** If the block provides 80 percent or more pain reduction as measured by a numerical pain index scale within one hour of the medial branch blocks up to three levels per side, then rhizotomy of the medial branch nerves, up to four nerves per side, may be done without confirmation block. If the initial set of medial branch blocks provides less than 80 percent but at least 50 percent pain reduction as measured by a numerical pain index scale or documented functional improvement, the medial branch

block should be repeated for confirmation before a rhizotomy is performed. If 50 percent or greater pain reduction is achieved as measured by the NPIS with two sets of medial branch blocks for facet joint pain, then rhizotomy may be performed.

(i). Frequency and maximum duration may be repeated once for comparative blocks. Limited to four levels.

(ii). Frequency and maximum duration may be repeated once for comparative blocks. Limited to four levels / five medial branches.

(b). **Atlanto-axial and atlanto-occipital injections** are generally accepted for diagnosis and treatment but do not lend themselves to denervation techniques owing to variable neuroanatomy. Injection of this articulation is complicated by the proximity of the vertebral artery, which may be tortuous at the level of the C1 joint. Inadvertent injection of the vertebral artery may cause respiratory arrest, seizure, stroke, or permanent neurological sequelae. Only practitioners skilled in these injections should perform them:

(i). frequency and maximum duration: once per side.

(c). **Transforaminal injections / Spinal selective nerve root blocks** are generally accepted and useful in identifying spinal pathology. When performed for diagnosis, small amounts of local anesthetic should be used to determine the level of nerve root irritation. A positive diagnostic block should result in a positive diagnostic functional benefit and a 50 percent reduction in nerve-root generated pain appropriate for the anesthetic used as measured by accepted pain scales (such as a VAS):

(i). time to produce effect: less than 30 minutes for local anesthesia; corticosteroids up to 72 hours for most patients;

(ii). frequency and maximum duration: once per suspected level. limited to two levels.

(d). **Zygapophyseal (Facet) Blocks.** Facet blocks are generally accepted but should not be considered diagnostic blocks for the purposes of determining the need for a rhizotomy (radiofrequency medial branch neurotomy), nor should they be done with medial branch blocks. These blocks should not be considered a definitive diagnostic tool. They may be used diagnostically to direct functional rehabilitation programs. A positive diagnostic block should result in a positive diagnostic functional benefit and a 50 percent reduction in pain appropriate for the anesthetic used as measured by accepted pain scales (such as a VAS). They then may be repeated per the therapeutic guidelines when they are accompanied by a functional rehabilitation program. (Refer to Therapeutic Spinal Injections):

(i). time to produce effect: less than 30 minutes for local anesthesia; corticosteroids up to 72 hours for most patients;

(ii). frequency and maximum duration: once per suspected level, limited to two levels.

c. Personality/ Psychological/ Psychiatric/ Psychosocial Evaluation. These are generally accepted and well-established diagnostic procedures with selective use in the upper extremity population, but have more widespread use in subacute and chronic upper extremity populations. Diagnostic testing procedures may be useful for patients with symptoms of depression, delayed recovery, chronic pain, recurrent painful conditions, disability problems, and for preoperative evaluation. Psychological/psychosocial and measures have been shown to have predictive value for postoperative response, and therefore should be strongly considered for use pre-operatively when the surgeon has concerns about the relationship between symptoms and findings, or when the surgeon is aware of indications of psychological complication or risk factors for psychological complication (e.g. childhood psychological trauma). Psychological testing should provide differentiation between pre-existing conditions versus injury caused psychological conditions, including depression and posttraumatic stress disorder. Psychological testing should incorporate measures that have been shown, empirically, to identify comorbidities or risk factors that are linked to poor outcome or delayed recovery.

i. Formal psychological or psychosocial evaluation should be performed on patients not making expected progress within 6 to 12 weeks following injury and whose subjective symptoms do not correlate with objective signs and test results. In addition to the customary initial exam, the evaluation of the injured worker should specifically address the following areas:

- (a). employment history;
- (b). interpersonal relationships-both social and work;
- (c). patient activities;
- (d). current perception of the medical system;
- (e). current perception/attitudes toward employer/job
- (f). results of current treatment
- (g). risk factors and psychological comorbidities that may influence outcome and that may require treatment
- (h). childhood history, including history of childhood psychological trauma, abuse and family history of disability.

ii. Personality/ psychological/ psychosocial evaluations consist of two components, clinical interview and psychological testing. Results should help clinicians with a better understanding of the patient in a number of ways. Thus the evaluation result will determine the need for further psychosocial interventions; and in those cases, Diagnostic and Statistical Manual of Mental Disorders (DSM) diagnosis should be determined and documented. The evaluation should also include examination of both psychological comorbidities and psychological risk factors that are empirically associated with poor outcome and/or delayed recovery. An individual with a Ph.D., Psy.D, or

psychiatric M.D./D.O. credentials should perform initial evaluations, which are generally completed within one to two hours. A professional fluent in the primary language of the patient is preferred. When such a provider is not available, services of a professional language interpreter should be provided.

iii. Frequency: one-time visit for the clinical interview. If psychometric testing is indicated as a part of the initial evaluation, time for such testing should not exceed an additional two hours of professional time.

d. Provocation Discography

i. Description. Discography is not recommended for use in the cervical spine.

3. Special tests are generally well-accepted tests and are performed as part of a skilled assessment of the patients' capacity to return-to-work, his/her strength capacities, and physical work demand classifications and tolerance. The procedures in this subsection are listed in alphabetical order, not by importance.

a. Computer-Enhanced Evaluations may include isotonic, isometric, isokinetic and/or isoinertial measurement of movement, range-of-motion, endurance, or strength. Values obtained can include degrees of motion, torque forces, pressures, or resistance. Indications include determining validity of effort, effectiveness of treatment and demonstrated motivation. These evaluations should not be used alone to determine return-to-work restrictions.

i. Frequency: One time for evaluation. Can monitor improvements in strength every three to four weeks up to a total of six evaluations.

b. Functional Capacity Evaluation (FCE): is a comprehensive or modified evaluation of the various aspects of function as they relate to the worker's ability to return to work. Areas such as endurance, lifting (dynamic and static), postural tolerance, specific range-of-motion, coordination and strength, worker habits, employability, as well as psychosocial, cognitive, and sensory perceptual aspects of competitive employment may be evaluated. Components of this evaluation may include: musculoskeletal screen; cardiovascular profile/aerobic capacity; coordination; lift/carrying analysis; job-specific activity tolerance; maximum voluntary effort; pain assessment/psychological screening; non-material and material handling activities cognitive; visual; and sensory perceptual factors.

i. When an FCE is being used to determine return to a specific jobsite, the provider is responsible for fully understanding the job duties. A jobsite evaluation is frequently necessary. FCEs cannot be used in isolation to determine work restrictions. The authorized treating physician must interpret the FCE in light of the individual patient's presentation and medical and personal perceptions. FCEs should not be used as the sole criteria to diagnose malingering.

ii. Full FCEs are sometimes not necessary. If Partial FCEs are performed, it is recognized that all parts of

the FCE that are not performed are considered normal. In many cases, a work tolerance screening will identify the ability to perform the necessary job tasks.

iii. Frequency: can be used initially to determine baseline status. Additional evaluations can be performed to monitor and assess progress and aid in determining the endpoint for treatment.

c. Job site evaluation is a comprehensive analysis of the physical, mental and sensory components of a specific job. These components may include, but are not limited to; postural tolerance (static and dynamic); aerobic requirements; range-of-motion; torque/force; lifting/carrying; cognitive demands; social interactions; visual perceptual; sensation; coordination; environmental requirements of a job; repetitiveness; and essential job functions.

i. Job descriptions provided by the employer are helpful but should not be used as a substitute for direct observation. A jobsite evaluation may include observation and instruction of how work is done, what material changes (desk, chair) should be made, and determination of readiness to return-to-work.

ii. Requests for a jobsite evaluation should describe the expected goals for the evaluation. Goals may include, but are not limited to the following.

(a). to determine if there are potential contributing factors to the person's condition and/or for the physician to assess causality;

(b). to make recommendations for, and to assess the potential for ergonomic changes;

(c). to determine the essential demands of the job. To provide a detailed description of the physical and cognitive job requirements;

(d). to assist the patient in their return-to-work by educating them on how they may be able to do their job more safely and in a more bio-mechanically appropriate manner;

(e). to give detailed work/activity restrictions.

iii. Frequency: One time with additional visits as needed for follow-up per jobsite.

d. Vocational Assessment. The vocational assessment should provide valuable guidance in the determination of future rehabilitation program goals. It should clarify rehabilitation goals, which optimize both patient motivation and utilization of rehabilitation resources. If prognosis for return to former occupation is determined to be poor, except in the most extenuating circumstances, vocational assessment should be implemented within 3 to 12 months post-injury. Declaration of MMI should not be delayed solely due to lack of attainment of a vocational assessment:

i. frequency: one time with additional visits as needed for follow-up.

e. Work tolerance screening is a determination of an individual's tolerance for performing a specific job based on a job activity or task and may be used when a full Functional Capacity Evaluation is not indicated. It may include a test or procedure to specifically identify and quantify work-relevant cardiovascular, physical fitness and postural tolerance. It may also address ergonomic issues affecting the patient's return-to-work potential. Full job description should include a physical assessment of the job requirements:

i. frequency: one time for initial screen. May monitor improvements in strength every 3 to 4 weeks up to a total of six visits.

AUTHORITY NOTE: Promulgated in accordance with R.S. 23:1203.1.

HISTORICAL NOTE: Promulgated by the Louisiana Workforce Commission, Office of Workers Compensation Administration, LR 37:1634 (June 2011), amended by the Louisiana Workforce Commission, Office of Workers Compensation, LR 40:1121 (June 2014), LR 49:517 (March 2023), LR 50:692 (May 2024).

### **§2009. Therapeutic Procedures—Non-Operative**

A. Before initiation of any therapeutic procedure, the authorized treating provider, employer, and insurer must consider these important issues in the care of the injured worker.

B. First, patients undergoing therapeutic procedure(s) should be released or returned to modified or restricted duty during their rehabilitation at the earliest appropriate time. Refer to "Return-to-Work" in this section for detailed information.

C. Second, cessation and/or review of treatment modalities should be undertaken when no further significant subjective or objective improvement in the patient's condition is noted. If patients are not responding within the recommended duration periods, alternative treatment interventions, further diagnostic studies or consultations should be pursued.

1. Reassessment of the patient's status in terms of functional improvement should be documented after each treatment. If patients are not responding within the recommended time periods, alternative treatment interventions, further diagnostic studies or consultations should be pursued. Continued treatment should be monitored using objective measures such as:

a. return-to-work or maintaining work status;

b. fewer restrictions at work or performing activities of daily living;

c. decrease in usage of medications;

d. measurable functional gains, such as increased range of motion or documented increase in strength;

D. Third, providers should provide and document education to the patient. No treatment plan is complete without addressing issues of individual and/or group patient education as a means of facilitating self-management of symptoms



E. Lastly, formal psychological or psychosocial evaluation should be performed on patients not making expected progress within 6 to 12 weeks following injury and whose subjective symptoms do not correlate with objective signs and tests.

F. Home therapy is an important component of therapy and may include active and passive therapeutic procedures as well as other modalities to assist in alleviating pain, swelling, and abnormal muscle tone.

G. The following procedures are listed in alphabetical order.

1. Acupuncture is an accepted and widely used procedure for the relief of pain and inflammation, and there is some scientific evidence to support its use. The exact mode of action is only partially understood. Western medicine studies suggest that acupuncture stimulates the nervous system at the level of the brain, promotes deep relaxation, and affects the release of neurotransmitters. Acupuncture is commonly used as an alternative or in addition to traditional Western pharmaceuticals. While it is commonly used when pain medication is reduced or not tolerated, it may be used as an adjunct to physical rehabilitation and/or surgical intervention to hasten the return of functional activity. Acupuncture should be performed by licensed practitioners.

a. Acupuncture is the insertion and removal of filiform needles to stimulate acupoints (acupuncture points). Needles may be inserted, manipulated, and retained for a period of time. Acupuncture can be used to reduce pain, reduce inflammation, increase blood flow, increase range-of-motion, decrease the side effect of medication-induced nausea, promote relaxation in an anxious patient, and reduce muscle spasm. Indications include joint pain, joint stiffness, soft tissue pain and inflammation, paresthesia, post-surgical pain relief, muscle spasm, and scar tissue pain.

b. Acupuncture with Electrical Stimulation: is the use of electrical current (micro-amperage or milli-amperage) on the needles at the acupuncture site. It is used to increase effectiveness of the needles by continuous stimulation of the acupoint. Physiological effects (depending on location and settings) can include endorphin release for pain relief, reduction of inflammation, increased blood circulation, analgesia through interruption of pain stimulus, and muscle relaxation.

i. It is indicated to treat chronic pain conditions, radiating pain along a nerve pathway, muscle spasm, inflammation, scar tissue pain, and pain located in multiple sites.

c. Total Time Frames for Acupuncture and Acupuncture with Electrical Stimulation: Time frames are not meant to be applied to each of the above sections separately. The time frames are to be applied to all acupuncture treatments regardless of the type or combination of therapies being provided.

i. Time to Produce Effect: three to six treatments

ii. Frequency: one to three times per week.

iii. Optimum Duration: one to two months.

iv. Maximum Duration: 14 treatments.

v. Any of the above acupuncture treatments may extend longer if objective functional gains can be documented or when symptomatic benefits facilitate progression in the patient's treatment program. Treatment beyond 14 treatments must be documented with respect to need and ability to facilitate positive symptomatic or functional gains. Such care should be re-evaluated and documented with each series of treatments.

d. Other Acupuncture Modalities. Acupuncture treatment is based on individual patient needs and therefore treatment may include a combination of procedures to enhance treatment effect. Other procedures may include the use of heat, soft tissue manipulation/massage, and exercise. Refer to active therapy (therapeutic exercise) and passive therapy sections (massage and superficial heat and cold therapy) for a description of these adjunctive acupuncture modalities and time frames.

2. Biofeedback is a form of behavioral medicine that helps patients learn self-awareness and self-regulation skills for the purpose of gaining greater control of their physiology, such as muscle activity, brain waves, and measures of autonomic nervous system activity. Electronic instrumentation is used to monitor the targeted physiology and then displayed or fed back to the patient visually, auditorially, or tactilely, with coaching by a biofeedback specialist. Biofeedback is provided by clinicians certified in biofeedback and/or who have documented specialized education, advanced training, or direct or supervised experience qualifying them to provide the specialized treatment needed (e.g., surface EMG, EEG, or other).

a. Treatment is individualized to the patient's work-related diagnosis and needs. Home practice of skills is required for mastery and may be facilitated by the use of home training tapes. The ultimate goal of biofeedback treatment is to normalize the physiology to the pre-injury status to the extent possible, and involves transfer of learned skills to the workplace and daily life. Candidates for biofeedback therapy or training must be motivated to learn and practice biofeedback and self-regulation techniques.

b. Indications for biofeedback include individuals who are suffering from musculoskeletal injury in which muscle dysfunction or other physiological indicators of excessive or prolonged stress response affects and/or delays recovery. Other applications include training to improve self-management of emotional stress/pain responses such as anxiety, depression, anger, sleep disturbance, and other central and autonomic nervous system imbalances. Biofeedback is often used in conjunction with other treatment modalities:

i. time to produce effect: three to four sessions;

ii. frequency: one to two times per week;

iii. optimum duration: five to six sessions;

iv. maximum duration: 10 to 12 sessions. Treatment beyond 12 sessions must be documented with respect to need, expectation, and ability to facilitate positive functional gains.

### 3. Injections—Therapeutic

a. **Therapeutic Spinal Injections.** Therapeutic spinal injections may be used after initial conservative treatments, such as physical and occupational therapy, medication, manual therapy, exercise, acupuncture, have been undertaken. Therapeutic injections should be used only after imaging studies and diagnostic injections have established pathology. Injections are invasive procedures that can cause catastrophic complications; thus clinical indications and contraindications should be closely adhered to. The purpose of spinal injections is to facilitate active therapy by providing short-term relief through reduction of pain and inflammation. All patients should continue appropriate exercise with functionally directed rehabilitation. Active treatment, which patients should have had prior to injections, will frequently require a repeat of the sessions previously ordered (Refer to Active Therapy). Injections, by themselves, are not likely to provide long-term relief. Rather, active rehabilitation with modified work achieves long-term relief by increasing active ROM, strength, and stability. Subjective reports of pain response (via a recognized pain scale) and function should be considered and given relative weight when the pain has anatomic and physiologic correlation. Anatomic correlation must be based on objective findings.

i. **Special Considerations—**for all injections (excluding trigger point and occipital nerve blocks) multi-planar fluoroscopy, during procedures is required to document technique and needle placement, and should be performed by a physician experienced in the procedure. Permanent images are required to verify needle placement. The subspecialty disciplines of the physicians performing injections may be varied, including, but not limited to: anesthesiology, radiology, surgery, neurology or physiatry. The practitioner should have completed fellowship training in pain medicine with interventional training, or its equivalent. They must also be knowledgeable in radiation safety.

ii. **Complications.** Appropriate medical disclosures with regard to potential complications should be provided to the patient as deemed appropriate by the treating physician.

iii. **Contraindications.** Absolute contraindications to therapeutic injections include: bacterial infection – systemic or localized to region of injection, bleeding diatheses, hematological conditions, and possible pregnancy.

(a). Relative contraindications to diagnostic injections may include: allergy to contrast, poorly controlled diabetes mellitus and hypertension. Drugs affecting coagulation may require restriction from use. Anti-platelet therapy and anti-coagulations should be addressed individually by a knowledgeable specialist. It is

recommended to refer to American Society of Regional Anesthesia for anticoagulation guidelines.

### b. Cervical Epidural Steroid Injection (ESI)

i. **Description.** Cervical ESIs are injections of corticosteroid into the epidural space. The purpose of ESI is to reduce pain and inflammation in the acute or subacute phases of injury, restoring range-of-motion, and thereby, facilitating progress in more active treatment programs.

ii. **Needle Placement.** Multi-planar fluoroscopic imaging is required for all epidural steroid injections. Contrast epidurograms allow one to verify the flow of medication into the epidural space. Permanent images are required to verify needle placement.

### iii. Indications

(a). Cervical ESIs are useful in patients with symptoms of cervical radicular pain syndromes. They have less defined usefulness in non-radicular pain. There is some evidence that epidural steroid injections are effective for patients with radicular pain or radiculopathy (sensory or motor loss in a specific dermatome or myotome). In one study, 53 percent of patients had 50 percent or greater relief of pain at 6 months with only 20 percent having similar relief at 12 months.

(b). There is some evidence to suggest that epidural injections are not effective for cervical axial pain; however, it is an accepted intervention. Only patients who have pain affected by activity and annular tears verified by appropriate imaging may have injections for axial pain.

(c). There is some evidence in studies of the lumbar spine that patients who smoke or who have pain unaffected by rest or activity are less likely to have a successful outcome from ESIs. This may also apply to the cervical spine although there are currently no studies to verify this finding. MRI or CT scans are required prior to thoracic and cervical ESIs, to assure that adequate epidural space is present.

### iv. Time/Frequency/Duration

(a). **Time to Produce Effect.** Local anesthetic, less than 30 minutes; corticosteroid, 48 to 72 hours for 80 percent of patients and 72 hours to 2 weeks for 20 percent of patients.

(b). **Frequency.** One or more divided levels can be injected in one session. Whether injections are repeated depends upon the patient's response to the previous injection. Subsequent injections may occur after one to two weeks if there is a positive patient response. Positive patient response results are defined primarily as functional gains that can be objectively measured. Objective functional gains include, but are not limited to, positional tolerances, range of motion (ROM), strength, endurance, activities of daily living, cognition, psychological behavior, and efficiency/velocity measures that can be quantified. Subjective reports of pain response (via a recognized pain scale) and function should be considered and given relative weight when the pain has anatomic and physiologic

correlation. Anatomic correlation must be based on objective findings.

(c). Injections can be repeated after a hiatus of six months if the patient has demonstrated functional gain and pain returns or worsens. If the first injection does not provide a diagnostic response with temporary and sustained pain relief (at least two to six weeks) substantiated by accepted pain scales (i.e., 50 percent pain reduction as measured by tools such as VAS), and improvement in function, similar injections should not be repeated.

(d). Optimal Duration. Usually one to three injection(s), over a period of six months depending upon each patient's response and functional gain.

(e). Maximum Duration: Two sessions consisting of up to three injections each may be done in one year, as per the patient's response to pain and function. Patients should be reassessed after each injection for a 50 percent improvement in pain (as measured by accepted pain scales) and evidence of functional improvement.

### c. Zygapophyseal (Facet) Injection

i. Description. A generally accepted intra-articular or pericapsular injection of local anesthetic and corticosteroid. There is conflicting evidence to support long-term therapeutic effect using facet injections. There is no justification for a combined facet and medial branch block.

ii. Indications. Patients with pain suspected to be facet in origin based on exam findings and affecting activity; or patients who have refused a rhizotomy; or patients who have facet findings with a thoracic component. In these patients, facet injections may be occasionally useful in facilitating a functionally-directed rehabilitation program and to aid in identifying pain generators. Patients with recurrent pain should be evaluated with more definitive diagnostic injections, such as medial nerve branch injections, to determine the need for a rhizotomy. Because facet injections are not likely to produce long-term benefit by themselves and are not the most accurate diagnostic tool, they should not be performed at more than two levels.

### iii. Timing/Frequency/Duration

(a). Time to Produce Effect: Up to 30 minutes for local anesthetic; corticosteroid up to 72 hours.

(b). Frequency: 1 injection per level with a diagnostic response. If the first injection does not provide a diagnostic response of temporary and sustained pain relief substantiated by accepted pain scales, (i.e., 50 percent pain reduction substantiated by tools such as VAS), and improvement in function, similar injections should not be repeated. At least four to six weeks of functional benefit should be obtained with each therapeutic injection.

(c). Optimum Duration: two to three injections for each applicable joint per year. Not to exceed two joint levels.

(d). Maximum Duration: four per level per year. Prior authorization must be obtained for injections beyond two levels.

(e). Facet injections may be repeated if they result in increased documented functional benefit for at least 4 to 6 weeks and at least a 50 percent initial improvement in pain scales as measured by accepted pain scales (such as VAS).

d. Intradiscal Steroid Therapy. Intradiscal steroid therapy consists of injection of a steroid preparation into the intervertebral disc under fluoroscopic guidance at the time of discography. There is good evidence that it is not effective in the treatment of suspected discogenic low back pain. There is no support for its use in the cervical spine and its use is not recommended.

### e. Radio Frequency (RF) Medial Branch Neurotomy/ Facet Rhizotomy

i. Description. A procedure designed to denervate the facet joint by ablating the corresponding sensory medial branches. Continuous percutaneous radio-frequency is the method generally used.

ii. There is good evidence to support this procedure in the cervical spine but benefits beyond one year are not yet established. Radio-frequency medial branch neurotomy is the procedure of choice over alcohol, phenol, or cryoablation. Precise positioning of the probe under fluoroscopic guidance is required since the maximum effective diameter of the device is a 5 x 8 millimeter oval. Permanent images should be recorded to verify placement of the device.

iii. Indications. Those patients with proven, significant, facetogenic pain. This procedure is not recommended for patients with multiple pain generators or involvement of more than three medial branch nerves.

iv. Individuals should have met the following indications: pain of well-documented facet origin, unresponsive to active and/or passive therapy. It is generally recommended that this procedure not be performed until three months of active therapy and manual therapy have been completed unless severe pain or limitation of ROM preclude patient participation. All patients should continue appropriate exercise with functionally directed rehabilitation. Active treatment, which patients will have had prior to the procedure, will frequently require a repeat of the sessions previously ordered (Refer to Active Therapy).

v. Complications. Appropriate medical disclosures should be provided to the patient as deemed necessary by the treating physician.

vi. Post-Procedure Therapy. Active therapy. Implementation of a gentle reconditioning program within the first post-procedure week is recommended, barring complications. Instruction and participation in a long-term home-based program of ROM, cervical, scapular, and thoracic strengthening, postural or neuromuscular re-education, endurance, and stability exercises should be

accomplished over a period of four to ten visits post-procedure.

vii. Requirements for repeat RF neurotomy (or additional level RF neurotomies). In some cases pain may recur [ISIS]. Successful rhizotomy usually provides from six to eighteen months of relief.

(a). Before a repeat RF neurotomy is done, a confirmatory medial branch injection should be performed if the patient's pain pattern presents differently than in the initial evaluation. In occasional patients, additional levels of RF neurotomy may be necessary. The same indications and limitations apply.

viii. Post-Procedure Therapy. Active therapy. Implementation of a gentle reconditioning program within the first post-procedure week is recommended, barring complications. Instruction and participation in a long-term home-based program of ROM, cervical, scapular, and thoracic strengthening, postural or neuromuscular re-education, endurance, and stability exercises should be accomplished over a period of four to ten visits post-procedure.

ix. Requirements for repeat RF neurotomy (or additional level RF neurotomies). In some cases pain may recur [ISIS]. Successful rhizotomy usually provides from six to eighteen months of relief.

(a). Before a repeat RF neurotomy is done, a confirmatory medial branch injection should be performed if the patient's pain pattern presents differently than in the initial evaluation. In occasional patients, additional levels of RF neurotomy may be necessary. The same indications and limitations apply.

f. Occipital Nerve Block

i. Description. Occipital nerve blocks are generally accepted injections used both diagnostically and therapeutically in the treatment of occipital neuralgia. The greater occipital nerve is the target.

ii. Indications. Diagnosis and treatment of occipital neuralgia/cephalgia. Peripheral block of the greater occipital nerve may be appropriate as initial treatment. It may be indicated in patients unresponsive to peripheral nerve block or those patients in need of additional diagnostic information.

iii. Complications. Bleeding, infection, neural injury. Post procedural ataxia is common and usually lasts 30 minutes post procedure. Because the occipital artery runs with the occipital nerve, inadvertent intravascular injection is a risk of this procedure and may lead to systemic toxicity and/or seizures.

(a). Time to Produce Effect: Approximately 30 minutes for local anesthetic; 48 to 72 hours for corticosteroid.

(b). Optimal Duration: one to three sessions for each nerve

(c). Maximum Duration: Continue up to three injections if progressive symptomatic and functional improvement can be documented.

g. Trigger Point Injections

i. Description. Trigger point injections are a generally accepted treatment. Trigger point treatment can consist of injection of local anesthetic with or without, corticosteroid into highly localized, extremely sensitive bands of skeletal muscle fibers that produce local and referred pain when activated. Medication is injected in a four-quadrant manner in the area of maximum tenderness. Injection efficacy can be enhanced if injections are immediately followed by myofascial therapeutic interventions, such as vapo-coolant spray and stretch, ischemic pressure massage (myotherapy), specific soft tissue mobilization and physical modalities. There is conflicting evidence regarding the benefit of trigger point injections. A truly blinded study comparing dry needle treatment of trigger points is not feasible. There is no evidence that injection of medications improves the results of trigger-point injections. Needling alone may account for some of the therapeutic response.

ii. There is no indication for conscious sedation for patients receiving trigger point injections. The patient must be alert to help identify the site of the injection.

iii. Indications. Trigger point injections may be used to relieve myofascial pain and facilitate active therapy and stretching of the affected areas. They are to be used as an adjunctive treatment in combination with other treatment modalities such as functional restoration programs. Trigger point injections should be utilized primarily for the purpose of facilitating functional progress. Patients should continue in an aggressive aerobic and stretching therapeutic exercise program as tolerated throughout the time period they are undergoing intensive myofascial interventions. Myofascial pain is often associated with other underlying structural problems and any abnormalities need to be ruled out prior to injection.

iv. Trigger point injections are indicated in those patients where well circumscribed trigger points have been consistently observed, demonstrating a local twitch response, characteristic radiation of pain pattern and local autonomic reaction, such as persistent hyperemia following palpation. Generally, these injections are not necessary unless consistently observed trigger points are not responding to specific, noninvasive, myofascial interventions within approximately a six-week time frame.

v. Complications. Potential but rare complications of trigger point injections include infection, pneumothorax, anaphylaxis, neurapraxia, and neuropathy. If corticosteroids are injected in addition to local anesthetic, there is a risk of local myopathy developing. Severe pain on injection suggests the possibility of an intraneural injection, and the needle should be immediately repositioned.

vi. Timing/Frequency/Duration

(a). Time to Produce Effect: Local anesthetic 30 minutes; no anesthesia 24 to 48 hours

(b). Frequency: Weekly, suggest no more than four injection sites per session per week to avoid significant post-injection soreness

(c). Optimal Duration: four Weeks

(d). Maximum Duration: eight weeks. Occasional patients may require two to four repetitions of trigger point injection series over a one to two year period.

h. Prolotherapy: also known as sclerotherapy consists of a series of injections of hypertonic dextrose, with or without glycerine and phenol, into the ligamentous structures of the neck. There is no evidence that Prolotherapy is effective in cervical pain. The injections are invasive, may be painful to the patient, and are not generally accepted or widely used. Therefore, the use of Prolotherapy for cervical pain is not recommended.

4. Epiduroscopy and Epidural Lysis of Adhesions: is not recommended in the cervical spine secondary to the potential for dural puncture, hematoma, and spinal cord injury.

5. Medications/Pharmacy. Medication used in the treatment of cervical injuries is appropriate for controlling acute and chronic pain and inflammation. Use of medications will vary widely due to the spectrum of injuries from simple strains to post-surgical healing. All drugs should be used according to patient needs. A thorough medication history, including use of alternative and over the counter medications, should be performed at the time of the initial visit and updated periodically. Treatment for pain control is initially accomplished with acetaminophen and/or NSAIDs. The patient should be educated regarding the interaction with prescription and over-the-counter medications as well as the contents of over-the-counter herbal products. The following are listed in alphabetical order:

a. Acetaminophen: is an effective analgesic with antipyretic but not anti-inflammatory activity. Acetaminophen is generally well tolerated, causes little or no gastrointestinal irritation, and is not associated with ulcer formation. Acetaminophen has been associated with liver toxicity in overdose situations or in chronic alcohol use. Patients may not realize that many over-the-counter preparations may contain acetaminophen. The total daily dose of acetaminophen is recommended not to exceed 2250 mg per 24-hour period from all sources, including narcotic-acetaminophen combination preparations. Higher doses may result in liver toxicity.

i. Optimum Duration: 7 to 10 days.

ii. Maximum Duration: Chronic use as indicated on a case-by-case basis. Use of this substance long-term for three days per week or greater may be associated with rebound pain upon cessation.

b. Muscle Relaxants: are appropriate for muscle spasm with pain. There is strong evidence that muscle relaxants are more effective than placebo for providing

short-term pain relief in acute low back pain. Similar effects can be expected for cervical pain. When prescribing these agents, physicians must seriously consider side effects of drowsiness or dizziness, and the fact that benzodiazepines may be habit-forming.

i. Optimum Duration: one week.

ii. Maximum Duration: two weeks (or longer if used only at night)

c. Narcotics should be primarily reserved for the treatment of severe cervical pain. In mild-to-moderate cases of cervical pain, narcotic medication should be used cautiously on a case-by-case basis. Adverse effects include respiratory depression, the development of physical and psychological dependence, and impaired alertness.

d. Narcotic medications should be prescribed with strict time, quantity, and duration guidelines, and with definitive cessation parameters. Pain is subjective in nature and should be evaluated using a scale to rate effectiveness of the narcotic prescribed. Any use beyond the maximum should be documented and justified based on the diagnosis and/or invasive procedures.

i. Optimum Duration: three to seven days.

ii. Maximum Duration: two weeks. Use beyond two weeks is acceptable in appropriate cases. Refer to Chronic Pain Guidelines which gives a detailed discussion regarding medication use in chronic pain management.

e. Nonsteroidal Anti-Inflammatory Drugs (NSAIDs): are useful for pain and inflammation. In mild cases, they may be the only drugs required for analgesia. There are several classes of NSAIDs, and the response of the individual injured worker to a specific medication is unpredictable. For this reason, a range of NSAIDs may be tried in each case with the most effective preparation being continued. Patients should be closely monitored for adverse reactions. The US Food and Drug Administration advise that many NSAIDs may cause an increased risk of serious cardiovascular thrombotic events, myocardial infarction, and stroke, which can be fatal. Naproxen sodium does not appear to be associated with increased risk of vascular events. Administration of proton pump inhibitors, histamine 2 blockers, or prostaglandin analog misoprostol along with these NSAIDs may reduce the risk of duodenal and gastric ulceration but do not impact possible cardiovascular complications. Due to the cross-reactivity between aspirin and NSAIDs, NSAIDs should not be used in aspirin-sensitive patients, and should be used with caution in all asthma patients. NSAIDs are associated with abnormal renal function, including renal failure, as well as abnormal liver function. Certain NSAIDs may have interactions with various other medications. Individuals may have adverse events not listed above. Intervals for metabolic screening are dependent upon the patient's age, general health status and should be within parameters listed for each specific medication. Complete blood count (CBC), and liver and renal function should be monitored at least every six months in patients on chronic NSAIDs and initially when indicated.

i. Non-selective Nonsteroidal Anti-Inflammatory Drugs

(a). Includes NSAIDs and acetylsalicylic acid (aspirin). Serious GI toxicity, such as bleeding, perforation, and ulceration can occur at any time, with or without warning symptoms in patients treated with traditional NSAIDs. Physicians should inform patients about the signs and/or symptoms of serious gastrointestinal toxicity and what steps to take if they occur. Anaphylactoid reactions may occur in patients taking NSAIDs. NSAIDs may interfere with platelet function. Fluid retention and edema have been observed in some patients taking NSAIDs.

(i). Optimal Duration: one week.

(ii). Maximum Duration: one year Use of these substances long-term for (three days per week or greater) is associated with rebound pain upon cessation.

ii. Selective Cyclo-oxygenase-2 (COX-2) Inhibitors

(a). Selective cyclo-oxygenase-2 (COX-2) inhibitors are more recent NSAIDs and differ in adverse side effect profiles from the traditional NSAIDs. The major advantages of selective COX-2 inhibitors over traditional NSAIDs are that they have less gastrointestinal toxicity and no platelet effects. COX-2 inhibitors can worsen renal function in patients with renal insufficiency, thus renal function may need monitoring.

(b). COX-2 inhibitors should not be first-line for low risk patients who will be using an NSAID short term but are indicated in select patients for whom traditional NSAIDs are not tolerated. Serious upper GI adverse events can occur even in asymptomatic patients. Patients at high risk for GI bleed include those who use alcohol, smoke, are older than 65, take corticosteroids or anti-coagulants, or have a longer duration of therapy. Celecoxib is contraindicated in sulfonamide allergic patients.

(i). Optimal Duration: 7 to 10 days.

(ii). Maximum Duration: Chronic use is appropriate in individual cases. Use of these substances long-term (for three days per week or greater) is associated with rebound pain upon cessation.

f. Oral Steroids: have limited use but are accepted in cases requiring potent anti-inflammatory drug effect and should not be routinely recommended.

g. Intravenous Steroids: The risks of permanent neurological damage from acute spinal cord compression generally outweigh the risks of pharmacologic side effects of steroids in an emergent situation.

h. Psychotropic/Anti-anxiety/Hypnotic Agents: may be useful for treatment of mild and chronic pain, dysesthesias, sleep disorders, and depression. Antidepressant medications, such as tricyclics and Selective Serotonin Reuptake Inhibitors (SSRIs), are useful for affective disorder and chronic pain management. Tricyclic antidepressant

agents, in low dose, are useful for chronic pain but have more frequent side effects.

i. Anti-anxiety medications should generally be limited to short-term use. Combinations of the above agents may be useful.

ii. As a general rule, providers (physicians or medical psychologist) should access the patient's prior history of substance abuse or depression prior to prescribing any of these agents. Due to the habit-forming potential of the benzodiazepines and other drugs found in this class, they are not routinely recommended. Refer to the Chronic Pain Guidelines which give a detailed discussion regarding medication use in chronic pain management.

(a). Optimum Duration: one to six months.

(b). Maximum Duration: 6 to 12 months, with monitoring.

i. Tramadol: is useful in relief of pain and has been shown to provide pain relief equivalent to that of commonly prescribed NSAIDs. Although Tramadol may cause impaired alertness, it is generally well tolerated, does not cause gastrointestinal ulceration, or exacerbate hypertension or congestive heart failure. Tramadol should be used cautiously in patients who have a history of seizures or who are taking medication that may lower the seizure threshold, such as monoamine oxidase (MAO) inhibitors, SSRIs, and tricyclic antidepressants. This medication has physically addictive properties and withdrawal may follow abrupt discontinuation and is not recommended for those with prior opioid addiction.

i. Optimal Duration: three to seven days

ii. Maximum Duration: two weeks. Use beyond two weeks is acceptable in appropriate cases.

6. Occupational Rehabilitation Programs

a. Non-Interdisciplinary. These generally accepted programs are work-related, outcome-focused, individualized treatment programs. Objectives of the program include, but are not limited to, improvement of cardiopulmonary and neuro-musculoskeletal functions (strength, endurance, movement, flexibility, stability, and motor control functions), patient education, and symptom relief. The goal is for patients to gain full or optimal function and return to work. The service may include the time-limited use of passive modalities with progression to active treatment and/or simulated/real work.

i. Work Conditioning

(a). These programs are usually initiated once reconditioning has been completed but may be offered at any time throughout the recovery phase. It should be initiated when imminent return of a patient to modified or full duty is not an option, but the prognosis for returning the patient to work at completion of the program is at least fair to good.

(i). Length of Visit: one to two hours per day.

(ii). Frequency: two to five visits per week.

(iii). Optimum Duration: two to four weeks.

(iv). Maximum Duration: six weeks.

Participation in a program beyond six weeks must be documented with respect to need and the ability to facilitate positive symptomatic or functional gains.

ii. Work Simulation

(a). Work simulation is a program where an individual completes specific work-related tasks for a particular job and return to work. Use of this program is appropriate when modified duty can only be partially accommodated in the work place, when modified duty in the work place is unavailable, or when the patient requires more structured supervision. The need for work place simulation should be based upon the results of a Functional Capacity Evaluation and/or Jobsite Analysis.

(i). Length of Visit: two to six hours per day.

(ii). Frequency: two to five visits per week.

(iii). Optimum Duration: two to four weeks.

(iv). Maximum Duration: six weeks.

Participation in a program beyond six weeks must be documented with respect to need and the ability to facilitate positive symptomatic or functional gains.

b. Interdisciplinary—programs are well-established treatment for patients with sub-acute and functionally impairing cervical spine pain. They are characterized by a variety of disciplines that participate in the assessment, planning, and/or implementation of an injured workers program with the goal for patients to gain full or optimal function and return to work. There should be close interaction and integration among the disciplines to ensure that all members of the team interact to achieve team goals. Programs should include cognitive-behavioral therapy as there is good evidence for its effectiveness in patients with chronic low back pain and it is probably effective in cervical spine pain. These programs are for patients with greater levels of disability, dysfunction, deconditioning and psychological involvement. For patients with chronic pain, refer to the Chronic Pain Disorder Medical Treatment Guidelines.

i. Work Hardening

(a). Work Hardening is an interdisciplinary program addressing a patient's employability and return to work. It includes a progressive increase in the number of hours per day that a patient completes work simulation tasks until the patient can tolerate a full workday. This is accomplished by addressing the medical, psychological, behavioral, physical, functional, and vocational components of employability and return-to-work.

(b). This can include a highly structured program involving a team approach or can involve any of the components thereof. The interdisciplinary team should, at a minimum, be comprised of a qualified medical director who is board certified with documented training in occupational rehabilitation; team physicians having experience in

occupational rehabilitation; occupational therapy; physical therapy; case manager; and psychologist. As appropriate, the team may also include: chiropractor, RN, vocational specialist or Certified Biofeedback Therapist.

(i). Length of Visit: up to eight hours/day.

(ii). Frequency: two to five visits per week.

(iii). Optimal Duration: two to four weeks.

(iv). Maximum Duration: six weeks.

Participation in a program beyond six weeks must be documented with respect to need and the ability to facilitate positive symptomatic or functional gains.

ii. Spinal Cord Programs

(a). Spinal Cord Systems of Care provide coordinated, case-managed, and integrated service for people with spinal cord dysfunction, whether due to trauma or disease. The system includes an inpatient component in an organization licensed as a hospital and an outpatient component. Each component endorses the active participation and choice of the persons served throughout the entire program. The Spinal Cord System of Care also provides or formally links with key components of care that address the lifelong needs of the persons served.

(b). This can include a highly structured program involving a team approach or can involve any of the components thereof. The interdisciplinary team should, at a minimum, be comprised of a qualified medical director who is board certified and trained in rehabilitation, a case manager, occupational therapy, physical therapy, psychologist, rehabilitation RN and MD, and therapeutic recreation specialist. As appropriate, the team may also include: rehabilitation counselor, respiratory therapist, social worker, or speech-language pathologist.

(c). Timeframe durations for any spinal cord program should be determined based upon the extent of the patient's injury and at the discretion of the rehabilitation physician in charge.

7. Orthotics. Primary principles and objectives of the application of cervical orthosis include, control of the position through the use of control forces; application of corrective forces to abnormal curvatures; aid in spinal stability when soft tissues or osteoligamentous structures cannot sufficiently perform their role as spinal stabilizers; and restrict spinal segment movement after acute trauma or surgical procedure. In cases of traumatic cervical injury, the most important objective is the protection of the spinal cord and nerve root.

a. Cervical Collars

i. Soft Collars are well-tolerated by most patients but may not significantly restrict motion in any plane and are associated with delayed recovery. There is no evidence that their use promotes recovery from cervical sprain. In acute strain/sprain type injuries, use of cervical collars may prolong disability, limit early mobilization, promote psychological dependence, and limit self-activity. There is

some evidence that patients encouraged to continue usual activity have less neck stiffness and headache than patients placed in cervical collars following motor vehicle crashes.

ii. Rigid Collars, such as a Philadelphia Orthosis, are useful post-operative or in emergency situations. These collars restrict flexion and extension motion, and to a lesser degree, lateral bending and rotation. Duration of wear post-surgery is dependent upon the surgeon and degree of cervical healing but is generally not used beyond eight weeks.

b. Poster Appliances: such as the Miami brace, restrict flexion and extension motion to about the same degree as a Philadelphia collar, and to a greater degree, lateral bending and rotation. Not recommended in sprain or strain injuries.

c. Cervicothoracic Orthosis: such as Yale and sternal occipital mandibular immobilization (SOMI) type braces, restrict flexion and extension motion to a fuller degree than the Philadelphia collar and to a better degree lateral bending and rotation. Not recommended in sprain or strain type injuries.

d. Halo Devices: are used in the treatment of cervical fracture, dislocation, and instability at the discretion of the treating surgeon. Refer to Halo Devices in the Operative Treatment section.

e. Other Orthosis Devices and Equipment: Special orthosis or equipment may have a role in the rehabilitation of a cervical injury such as those injuries to a cervical nerve root resulting in upper extremity weakness or a spinal cord injury with some degree of paraparesis or tetraparesis. Use of such devices would be in a structured rehabilitation setting as part of a comprehensive rehabilitation program.

8. Patient education. No treatment plan is complete without addressing issues of individual and/or group patient education as a means of prolonging the beneficial effects of treatment, as well as, facilitating self-management of symptoms and injury prevention. The patient should be encouraged to take an active role in the establishment of functional outcome goals. They should be educated on their specific injury, assessment findings, and plan of treatment. Instruction on proper body mechanics and posture, positions to avoid, self-care for exacerbation of symptoms, and home exercise should also be addressed.

a. Time to Produce Effect: Varies with individual patient.

b. Frequency: Should occur at each visit.

9. Personality/psychological/psychiatric/ psychosocial intervention is a generally accepted, widely used, and well-established intervention. This group of therapeutic and diagnostic modalities includes, but is not limited to; individual counseling, group therapy, stress management, psychosocial crises intervention, hypnosis and meditation. Any evaluation or diagnostic workup should clarify and distinguish between pre-existing versus aggravated versus purely causative psychological conditions. Psychosocial

intervention is recommended as an important component in the total management program that should be implemented as soon as the problem is identified. This can be used alone or in conjunction with other treatment modalities. Providers treating patients with chronic pain should refer to the Chronic Pain Disorder Medical Treatment Guidelines.

a. Time to Produce Effect: two to four weeks.

b. Frequency: one to three times weekly for the first four weeks (excluding hospitalization, if required), decreasing to one to two times per week for the second month. Thereafter, two to four times monthly.

c. Optimum Duration: six weeks to three months.

d. Maximum Duration: 3 to 12 months. Counseling is not intended to delay but to enhance functional recovery. For select patients, longer supervised treatment may be required, and if further counseling beyond three months is indicated, extensive documentation addressing which pertinent issues are preexisting versus aggravated versus causative, as well as projecting a realistic functional prognosis, should be provided by the authorized treating practitioner every four to six weeks during treatment.

10. Restriction of activities. There is some evidence to support the continuation of normal daily activities as the recommended treatment for acute and chronic cervical injuries without neurologic symptoms. Complete work cessation should be avoided, if possible, since it often further aggravates the pain presentation. Modified return-to-work is almost always more efficacious and rarely contraindicated in the vast majority of injured workers with cervical spine injuries.

11. Return-to-work: Early return-to-work should be a prime goal in treating occupational injuries given the poor return-to-work prognosis for an injured worker who has been out of work for more than six months. It is imperative that the patient be educated regarding the benefits of return-to-work, restrictions, and follow-up if problems arise. When attempting to return a patient to work after a specific injury, clear objective restrictions of activity level should be made. An accurate job description with detailed physical duty descriptions is often necessary to assist the physician in making return-to-work recommendations. This may require a jobsite evaluation.

a. Employers should be prepared to offer transitional work. This may consist of temporary work in a less demanding position, return to the regular job with restrictions, or gradual return to the regular job. Company policies which encourage return-to-work with positive communication are most likely to have decreased worker disability.

b. Return-to-work is defined as any work or duty that the patient is able to perform safely. It may not be the patient's regular work. Due to the large spectrum of injuries of varying severity and varying physical demands in the work place, it is not possible to make specific return-to-work guidelines for each injury. Therefore, the OWCA recommends the following.



i. **Establishment of a Return-To-Work Status:** Ascertaining a return-to-work status is part of medical care, should be included in the treatment and rehabilitation plan, and addressed at every visit. A description of daily activity limitations is part of any treatment plan and should be the basis for restriction of work activities. In most non-surgical cases, the patient should be able to return to work in some capacity or in an alternate position consistent with medical treatment within several days unless there are extenuating circumstances. Injuries requiring more than two weeks off work should be thoroughly documented.

ii. **Establishment of Activity Level Restrictions:** Communication is essential between the patient, employer, and provider to determine appropriate restrictions and return-to-work dates. It is the responsibility of the physician to provide clear concise restrictions, and it is the employer's responsibility to determine if temporary duties can be provided within the restrictions. For cervical spine injuries, the following should be addressed when describing the patient's activity level:

(a). Total body position including upper trunk, especially rotation and flexion. To include duration and frequency.

(b). Upper extremity requirements including reaching above the shoulder, repetitive motions, pushing, pulling, and lifting or carrying requirements. Duration and frequency should be included.

(c). Sitting duration and frequency with regard to posture, work height(s), and movements of the head and neck.

(d). Visual field requirements in respect to limitations in head and neck movements and tolerance to looking upward and downward.

(e). Use of adaptive devices or equipment for proper office ergonomics or to enhance capacities can be included.

(f). The effect of any medications that may pose a safety risk to the patient, co-workers or the general public should be considered with regard to the workplace and home.

iii. **Compliance with Activity Restrictions:** In some cases, compliance with restriction of activity levels may require a complete jobsite evaluation, a functional capacity evaluation (FCE), or other special testing. Refer to the "Special Tests" section of this guideline.

12. **Therapy—Active.** The following active therapies are widely used and accepted methods of care for a variety of work-related injuries. They are based on the philosophy that therapeutic exercise and/or activity are beneficial for restoring flexibility, strength, endurance, function, range-of-motion, and can alleviate discomfort. Active therapy requires an internal effort by the individual to complete a specific exercise or task. This form of therapy requires supervision from a therapist or medical provider such as verbal, visual, and/or tactile instruction(s). At times, the provider may help

stabilize the patient or guide the movement pattern but the energy required to complete the task is predominately executed by the patient.

a. On occasion, specific diagnoses and post-surgical conditions may warrant durations of treatment beyond those listed as "maximum". Factors such as exacerbation of symptoms, re-injury, interrupted continuity of care and comorbidities may also extend durations of care. Specific goals with objectively measured functional improvement during treatment must be cited to justify extended durations of care. It is recommended that, if no functional gain is observed after the number of treatments under "time to produce effect" has been completed alternative treatment interventions, further diagnostic studies or further consultations should be pursued.

b. Patients should be instructed to continue active therapies at home as an extension of the treatment process in order to maintain improvement levels. Follow-up visits to reinforce and monitor progress and proper technique are recommended. Home exercise can include exercise with or without mechanical assistance or resistance and functional activities with assistive devices.

c. The following active therapies are listed in alphabetical order.

i. **Activities of Daily Living (ADL)** are well-established interventions which involve instruction, active-assisted training, and/or adaptation of activities or equipment to improve a person's capacity in normal daily activities such as self-care, work re-integration training, homemaking, and driving.

(a). **Time to Produce Effect:** four to five treatments.

(b). **Frequency:** three to five times per week.

(c). **Optimum Duration:** four to six weeks.

(d). **Maximum Duration:** six weeks.

ii. **Aquatic Therapy** is a well-accepted treatment which consists of the therapeutic use of aquatic immersion for therapeutic exercise to promote strengthening, core stabilization, endurance, range-of-motion, flexibility, body mechanics, and pain management. Aquatic therapy includes the implementation of active therapeutic procedures in a swimming or therapeutic pool. The water provides a buoyancy force that lessens the amount of force gravity applies to the body. The decreased gravity effect allows the patient to have a mechanical advantage and more likely have a successful trial of therapeutic exercise. The therapy may be indicated for individuals who:

(a). cannot tolerate active land-based or full-weight bearing therapeutic procedures;

(b). require increased support in the presence of proprioceptive deficit;

(c). are at risk of compression fracture due to decreased bone density;

## LABOR AND EMPLOYMENT

(d). have symptoms that are exacerbated in a dry environment;

(e). would have a higher probability of meeting active therapeutic goals than in a dry environment;

(f). the pool should be large enough to allow full extremity range-of-motion and fully erect posture. Aquatic vests, belts, and other devices may be used to provide stability, balance, buoyancy, and resistance.

(i). Time to Produce Effect: four to five treatments

(ii). Frequency: three to five times per week.

(iii). Optimum Duration: four to six weeks.

(iv). Maximum Duration: eight weeks.

(v.). A self-directed program is recommended after the supervised aquatics program has been established, or, alternatively a transition to a self-directed dry environment exercise program.

iii. Functional activities are well-established interventions which involve the use of therapeutic activities to enhance mobility, body mechanics, employability, coordination, balance, and sensory motor integration.

(a). Time to Produce Effect: four to five treatments

(b). Frequency: three to five times per week

(c). Optimum Duration: four to six weeks

(d). Maximum Duration: six weeks

iv. Functional electrical stimulation is an accepted treatment in which the application of electrical current to elicit involuntary or assisted contractions of atrophied and/or impaired muscles. It may be indicated for muscle atrophy due to radiculopathy.

(a). Time to Produce Effect: two to six treatments.

(b). Frequency: three times per week.

(c). Optimum Duration: eight weeks.

(d). Maximum Duration: eight weeks. If beneficial, provide with home unit.

v. Neuromuscular re-education is a generally accepted treatment. It is the skilled application of exercise with manual, mechanical, or electrical facilitation to enhance strength, movement patterns, neuromuscular response, proprioception, kinesthetic sense, and coordination, education of movement, balance, and posture. Indications include the need to promote neuromuscular responses through carefully timed proprioceptive stimuli, to elicit and improve motor activity in patterns similar to normal neurologically developed sequences, and improve neuromotor response with independent control.

(a). Time to Produce Effect: two to six treatments.

(b). Frequency: three times per week.

(c). Optimum Duration: four to eight weeks.

(d). Maximum Duration: eight weeks.

vi. Spinal stabilization is a generally accepted treatment. The goal of this therapeutic program is to strengthen the spine in its neural and anatomic position. The stabilization is dynamic which allows whole body movements while maintaining a stabilized spine. It is the ability to move and function normally through postures and activities without creating undue vertebral stress.

(a). Time to Produce Effect: four to eight treatments.

(b). Frequency: three to five times per week.

(c). Optimum Duration: four to eight weeks.

(d). Maximum Duration: eight weeks.

vii. Therapeutic exercise is a generally well-accepted treatment. Therapeutic exercise with or without mechanical assistance or resistance, may include isoinertial, isotonic, isometric and isokinetic types of exercises. Indications include the need for cardiovascular fitness, reduced edema, improved muscle strength, improved connective tissue strength and integrity, increased bone density, promotion of circulation to enhance soft tissue healing, improvement of muscle recruitment, improved proprioception and coordination, increased range-of-motion and are used to promote normal movement patterns. Therapeutic exercise can also include complementary/alternative exercise movement therapy (with oversight of a physician or appropriate healthcare professional).

(a). Time to Produce Effect: two to six treatments.

(b). Frequency: three to five times per week.

(c). Optimum Duration: four to eight weeks.

(d). Maximum Duration: eight weeks.

13. Therapy—Passive. Most of the following passive therapies and modalities are generally accepted methods of care for a variety of work-related injuries. Passive therapy includes those treatment modalities that do not require energy expenditure on the part of the patient. They are principally effective during the early phases of treatment and are directed at controlling symptoms such as pain, inflammation and swelling and to improve the rate of healing soft tissue injuries. They should be used adjunctively with active therapies such as postural stabilization and exercise programs to help control swelling, pain, and inflammation during the active rehabilitation process. Please refer to General Guideline Principles, Active Interventions. Passive therapies may be used intermittently as a therapist deems appropriate or regularly if there are specific goals

with objectively measured functional improvements during treatment.

a. On occasion, specific diagnoses and post-surgical conditions may warrant durations of treatment beyond those listed as "maximum". Factors such as exacerbation of symptoms, re-injury, interrupted continuity of care and comorbidities may also extend durations of care. Specific goals with objectively measured functional improvement during treatment must be cited to justify extended durations of care. It is recommended that, if no functional gain is observed after the number of treatments under "time to produce effect" has been completed alternative treatment interventions, further diagnostic studies or further consultations should be pursued.

i. The following passive therapies are listed in alphabetical order:

(a). Electrical Stimulation (Unattended): is an accepted treatment. Once applied, unattended electrical stimulation requires minimal on-site supervision by the physical therapist, occupational therapist, or other provider. Indications include pain, inflammation, muscle spasm, atrophy, decreased circulation, and the need for osteogenic stimulation. A home unit should be purchased if treatment is effective and frequent use is recommended.

(i). Time to Produce Effect: two to four treatments.

(ii). Frequency: Varies, depending upon indication, between two to three times/day to 1 time/week. A home unit should be purchased if treatment is effective and frequent use is recommended.

(iii). Optimum Duration: four treatments for clinic use.

(iv). Maximum Duration: eight treatments for clinic use.

(b). Iontophoresis: is an accepted treatment which consists of the transfer of medication, including, but not limited to, steroidal anti-inflammatories and anesthetics, through the use of electrical stimulation. Indications include pain (Lidocaine), inflammation (hydrocortisone, salicylate), edema (mecholy, hyaluronidase, salicylate), ischemia (magnesium, mecholy, iodine), muscle spasm (magnesium, calcium), calcific deposits (acetate), scars, and keloids (sodium chloride, iodine, acetate). There is no proven benefit for this therapy in the cervical spine.

(i). Time to Produce Effect: one to four treatments.

(ii). Frequency: 3 times per week with at least 48 hours between treatments.

(iii). Optimum Duration: four to six weeks.

(iv). Maximum Duration: six weeks.

(c). Manipulation: is a generally accepted, well-established, and widely used therapeutic intervention for cervical pain. Manipulative treatment (not therapy) is

defined as the therapeutic application of manually guided forces by an operator to improve physiologic function and/or support homeostasis that has been altered by the injury or occupational disease, and has associated clinical significance.

(i). High velocity, low amplitude (HVLA) technique, chiropractic manipulation, osteopathic manipulation, muscle energy techniques, counter strain, and non-force techniques are all types of manipulative treatment. This may be applied by osteopathic physicians (D.O.), chiropractors (D.C.), physical therapists (P.T.), occupational therapists (O.T.), or physicians. Under these different types of manipulation exist many subsets of different techniques that can be described as a) direct- a forceful engagement of a restrictive/pathologic barrier, b) indirect- a gentle/non-forceful dis-engagement of a restrictive/pathologic barrier, c) the patient actively assisting in the treatment and d) the patient relaxing, allowing the practitioner to move the body tissues. When the proper diagnosis is made and coupled with the appropriate technique, manipulation has no contraindications and can be applied to all tissues of the body. Pre-treatment assessment should be performed as part of each manipulative treatment visit to ensure that the correct diagnosis and correct treatment is employed.

(ii). High velocity, low amplitude (HVLA) manipulation is performed by taking a joint to its end range of motion and moving the articulation into the zone of accessory joint movement, well within the limits of anatomical integrity. There is good scientific evidence to suggest that HVLA manipulation can be effective for relieving pain and decreasing muscle spasm to improve function for patients with cervical pain. There is some evidence to show that manipulation of the cervical spine with exercise may be effective prophylactic treatment for cervicogenic headaches. Contraindications to HVLA manipulation include joint instability, fractures, severe osteoporosis, infection, metastatic cancer, active inflammatory arthritides, and signs of progressive neurologic deficits, myelopathy, vertebrobasilar insufficiency, or carotid artery disease. Relative contraindications include stenosis, spondylosis, and disc herniation.

b. Manipulation / Grade I - V

i. Time to produce effect for all types of manipulative treatment: one to six treatments.

ii. Frequency: Up to three times per week for the first four weeks as indicated by the severity of involvement and the desired effect, then up to two treatments per week for the next four weeks. For further treatments, twice per week or less to maintain function.

iii. Optimum Duration: 8 to 12 weeks.

iv. Maximum Duration: three months. Extended durations of care beyond what is considered "maximum" may be necessary in cases of re-injury, interrupted continuity of care, exacerbation of symptoms, and in those patients with comorbidities. Refer to the Chronic Pain Guidelines for care beyond three months.

c. Manipulation under General Anesthesia (MUA) refers to manual manipulation of the cervical spine in combination with the use of a general anesthetic or conscious sedation. It is intended to improve the success of manipulation when pain, muscle spasm, guarding, and fibrosis appear to be limiting its application in patients otherwise suitable for its use. There have been no high quality studies to justify MUAs benefits. Given the risks of general anesthetic and conscious sedation, it is not recommended.

d. Manipulation under Joint Anesthesia (MUJA) refers to manipulation of the cervical spine in combination with a fluoroscopically guided injection of anesthetic with or without corticosteroid agents into the facet joint at the level being manipulated. There are no controlled clinical trials to support its use. It is not recommended.

e. Massage. Manual or Mechanical. Massage is a generally well-accepted treatment consisting of manipulation of soft tissue with broad ranging relaxation and circulatory benefits. This may include stimulation of acupuncture points and acupuncture channels (acupressure), application of suction cups and techniques that include pressing, lifting, rubbing, pinching of soft tissues by or with the practitioner's hands. Indications include edema (peripheral or hard and non-pliable edema), muscle spasm, adhesions, the need to improve peripheral circulation and range-of-motion, or to increase muscle relaxation and flexibility prior to exercise.

i. As with all passive therapies, massage must be accompanied by exercise and patient education.

ii. Mobilization—Grade I - V

(a). Time to Produce Effect: Immediate

(b). Frequency: one to two times per week

(c). Optimum Duration: six weeks

(d). Maximum Duration: two months

f. Mobilization (Joint) is a generally well-accepted treatment consisting of passive movement involving oscillatory motions to the vertebral segment(s). The passive mobility is performed in a graded manner (I, II, III, IV, or V), which depicts the speed and depth of joint motion during the maneuver. For further discussion on Level V joint mobilization please see section on HVLA manipulation [Section 12. c.]. It may include skilled manual joint tissue stretching. Indications include the need to improve joint play, segmental alignment, improve intracapsular arthrokinematics, or reduce pain associated with tissue impingement. Mobilization should be accompanied by active therapy. For Level V mobilization, contraindications include joint instability, fractures, severe osteoporosis, infection, metastatic cancer, active inflammatory arthritis, and signs of progressive neurologic deficits, myelopathy, vertebrobasilar insufficiency, or carotid artery disease. Relative contraindications include stenosis, spondylosis, and disc herniation.

i. Time to Produce Effect: six to nine treatments.

ii. Frequency: Up to three times per week.

iii. Optimum Duration: four to six weeks.

iv. Maximum Duration: six weeks.

g. Intramuscular Manual Therapy: Dry Needling. IMT involves using filament needles to treat "Trigger Points" within muscle. It may require multiple advances of a filament needle to achieve a local twitch response to release muscle tension and pain. Dry needling is an effective treatment for acute and chronic pain of neuropathic origin with very few side effects. Dry needling is a technique to treat the neuro-musculoskeletal system based on pain patterns, muscular dysfunction and other orthopedic signs and symptoms.

i. Time to produce effect: immediate

ii. Frequency: one to two times a week

iii. Optimum duration: 6 weeks

iv. Maximum duration: 2 months

h. Mobilization (Soft Tissue): is a generally well-accepted treatment. Mobilization of soft tissue is the skilled application of muscle energy, strain/counter strain, myofascial release, manual trigger point release, and other manual therapy techniques designed to improve or normalize movement patterns through the reduction of soft tissue pain and restrictions. These can be interactive with the patient participating or can be with the patient relaxing and letting the practitioner move the body tissues. Indications include muscle spasm around a joint, trigger points, adhesions, and neural compression. Mobilization should be accompanied by active therapy.

i. Time to Produce Effect: four to nine treatments.

ii. Frequency: Up to three times per week.

iii. Optimum Duration: four to six weeks.

iv. Maximum Duration: six weeks.

i Short-Wave Diathermy is an accepted treatment which involves the use of equipment that exposes soft tissue to a magnetic or electrical field. Indications include enhanced collagen extensibility before stretching, reduced muscle guarding, reduced inflammatory response, and enhanced reabsorption of hemorrhage/hematoma or edema.

i. Time to Produce Effect: two to four treatments

ii. Frequency: two to three times per week up to three weeks

iii. Optimum Duration: three to five weeks

iv. Maximum Duration: five weeks

j. Superficial Heat and Cold Therapy (excluding Infrared Therapy) is a generally accepted treatment. Superficial heat and cold are thermal agents applied in various manners that lower or raise the body tissue temperature for the reduction of pain, inflammation, and/or effusion resulting from injury or induced by exercise. It

includes application of heat just above the surface of the skin at acupuncture points. Indications include acute pain, edema and hemorrhage, need to increase pain threshold, reduce muscle spasm, and promote stretching/flexibility. Cold and heat packs can be used at home as an extension of therapy in the clinic setting. Continuous cryotherapy units with compression are allowable in post-surgical orthopedic patients.

- i. Time to Produce Effect: Immediate
- ii. Frequency: two to five times per week
- iii. Optimum Duration: three weeks as primary or intermittently as an adjunct to other therapeutic procedures up to two months

- iv. Maximum Duration: two months

k. Traction-Manual—is an accepted treatment and an integral part of manual manipulation or joint mobilization. Indications include decreased joint space, muscle spasm around joints, and the need for increased synovial nutrition and response. Manual traction is contraindicated in patients with tumor, infection, fracture, or fracture dislocation.

- i. Time to Produce Effect: one to three sessions
- ii. Frequency: two to three times per week
- iii. Optimum Duration: 30 days
- iv. Maximum Duration: one month

l. Traction. Mechanical is a generally accepted treatment and most commonly used for patients with radicular findings. It is sometimes used to treat symptoms from decreased joint space and muscle spasm around the joints. If successful it should be shifted to home traction. Traction modalities are contraindicated in patients with tumor, infections, fracture, or fracture dislocation. Non-oscillating inversion traction methods are contraindicated in patients with glaucoma or hypertension. A home cervical traction unit may be purchased if therapy proves effective.

i. Time to Produce Effect: 1 to 3 sessions up to 30 minutes. If response is negative after 3 treatments, discontinue this modality

ii. Frequency: two to three times per week. A home cervical traction unit may be purchased if therapy proves effective.

- iii. Optimum Duration: four weeks.
- iv. Maximum Duration: four weeks.

m. Transcutaneous electrical nerve stimulation (TENS) is a generally accepted treatment which should include at least one instructional session for proper application and use. Indications include muscle spasm, atrophy, and decreased circulation and pain control. Minimal TENS unit parameters should include pulse rate, pulse width and amplitude modulation. Consistent, measurable, functional improvement must be documented prior to the purchase of a home unit.

- i. Time to Produce Effect: Immediate
- ii. Frequency: Variable
- iii. Optimum Duration: three sessions
- iv. Maximum Duration: three sessions. Purchase or provide with home unit if effective.

n. Ultrasound (including phonophoresis) is an accepted treatment which uses sonic generators to deliver acoustic energy for therapeutic thermal and/or non-thermal soft tissue effects. Indications include scar tissue, adhesions, collagen fiber and muscle spasm, and the need to extend muscle tissue or accelerate the soft tissue healing. Ultrasound with electrical stimulation is concurrent delivery of electrical energy that involves dispersive electrode placement. Indications include muscle spasm, scar tissue, pain modulation, and muscle facilitation.

i. Phonophoresis is the transfer of medication through the use of sonic generators to the target tissue to control inflammation and pain. These topical medications include, but are not limited to, steroidal anti-inflammatory and anesthetics.

- (a). Time to Produce Effect: 6 to 15 treatments
- (b). Frequency: three times per week
- (c). Optimum Duration: four to eight weeks
- (d). Maximum Duration: eight weeks

14. Vocational Rehabilitation is a generally accepted intervention. Initiation of vocational rehabilitation requires adequate evaluation of patients for quantification highest functional level, motivation, and achievement of maximum medical improvement. Vocational rehabilitation may be as simple as returning to the original job or as complicated as being retrained for a new occupation.

a. It may also be beneficial for full vocational rehabilitation to be started before MMI if it is evident that the injured worker will be unable to return to his/her previous occupation. A positive goal and direction may aid the patient in decreasing stress and depression and promote optimum rehabilitation.

AUTHORITY NOTE: Promulgated in accordance with R.S. 23:1203.1.

HISTORICAL NOTE: Promulgated by the Louisiana Workforce Commission, Office of Workers Compensation Administration, LR 37:1640 (June 2011), amended by the Louisiana Workforce Commission, Office of Workers Compensation, LR 40:1126 (June 2014), LR 49:518 (March 2023).

### **§2011. Therapeutic Procedures—Operative**

A. All operative interventions should be based on a positive correlation with clinical findings, the natural history of the disease, the clinical course, and diagnostic tests. A comprehensive assimilation of these factors should have led to a specific diagnosis with positive identification of the pathologic condition(s). It is imperative for the clinician to rule out non-physiologic modifiers of pain presentation, or non-operative conditions mimicking radiculopathy or instability (peripheral compressive neuropathy, chronic soft

tissue injuries, and psychological conditions), prior to consideration of elective surgical intervention. Early intervention may be required in acute incapacitating pain or in the presence of progressive neurological deficits. Patients who are not candidates for or refuse surgical treatment should be treated with non-operative therapy as indicated.

B. Operative treatment is indicated when the natural history of surgically treated lesions is better than the natural history for non-operatively treated lesions. All patients being considered for surgical intervention should first undergo a comprehensive neuromusculoskeletal examination to identify mechanical pain generators that may respond to non-surgical techniques, or may be refractory to surgical intervention.

1. Referral for surgical evaluation and treatment. Consultation should be made to an appropriate surgical specialist for surgical evaluation and treatment when operative treatment is considered.

a. The decision and recommendation for operative treatment, and the appropriate informed consent should be made by the operating surgeon.

b. Prior to surgical intervention, the patient and treating physician should identify functional operative goals and the likelihood of achieving improved ability to perform activities of daily living or work activities and the patient should agree to comply with the pre- and post-operative treatment plan and home exercise requirements. The patient should understand the length of partial and full disability expected post-operatively

C. In situations requiring the possible need for re-surgery, a second opinion may be necessary. Psychological evaluation is strongly encouraged when surgery is being performed for isolated axial pain to determine if the patient will likely benefit from the treatment.

D. Interdisciplinary interventions should be strongly considered post-operatively in patients not making functional progress within expected time frames (Refer to Interdisciplinary Programs).

E. Return to work activity restrictions should be specific according to the recommendations in Return to Work. Most cervical non-fusion surgical patients can return to a limited level of duty between three to six weeks. Full activity is generally achieved between six weeks to six months, depending on the procedure and healing of the individual.

#### F. Cervical Operative Procedures and Conditions

1. Acute fractures and dislocations: Decisions regarding the need for surgery in acute traumatic injury will depend on the specific injury type and possibility of long-term neurologic damage. Acute disc herniations may occur in the presence of traumatic injury.

##### a. Halo Immobilization

i. Description. Intervention that restricts flexion-extension motion. Halo vest will provide significant but not

complete rotational control and is the most effective device for treating unstable injuries to the cervical spine.

ii. Complications. May include pin infection, pin loosening, and palsy of the sixth cranial nerve.

iii. Surgical Indications. Cervical fractures requiring the need for nearly complete restriction of rotational control, and to prevent graft dislodgment, spine mal-alignment, or pseudarthrosis. Decision for use of halo is at the discretion of the surgeon based upon the patients' specific injury. Not indicated for unstable skull fractures or if skin overlying pin sites is traumatized.

iv. Operative Treatment. Placement of the pins and apparatus.

v. Post-Operative Therapy. Traction may be required for re-alignment and or fracture reduction (amount to be determined by surgeon), active and/or passive therapy, pin care.

##### b. Anterior or Posterior Decompression with Fusion

i. Description—to provide relief of pressure on the cervical spinal cord and nerve roots, and alignment and stabilization of the spine. May involve the use of bone grafts, sometimes combined with metal devices, to produce a rigid connection between two or more adjacent vertebrae.

ii. Complications—appropriate medical disclosures should be provided to the patient as deemed necessary by the treating physician.

iii. Surgical Indications—when a significant or progressive neurological deficit exists in the presence of spinal canal compromise. Whether early decompression and reduction of neural structures enhances neurological recovery continues to be debated. Currently, a reasonable approach would be to treat non-progressive neurological deficits on a semi-urgent basis, when the patient's systemic condition is medically stable.

iv. Operative Treatment—both anterior and posterior surgical decompression of the cervical spine are widely accepted. The approach is guided by location of the compressive pathology as well as the presence of other concomitant injuries. Posterior stabilization and fusion alone may be indicated for patients who have been realigned with traction and do not have significant canal compromise. The anterior approach is acceptable if there is disc and/or vertebral body anteriorly compromising the canal. The posterior approach may be indicated in radiculopathy in the absence of myelopathy and with evidence of pseudarthrosis on radiographs, or if the compression pathology is arising posteriorly.

(a). The number of levels involved in the fracture pattern determines the choice between the use of wire techniques versus spinal plates. In injuries treated with an anterior decompression procedure, anterior bone grafting alone does not provide immediate internal fixation and an anterior cervical plate is significantly beneficial. Patients who undergo surgery for significant fracture dislocations of

the spine (three level injury) with canal compromise are best managed with anterior cervical decompression, fusion, and plating but in some cases posterior stabilization and fusion are also considered.

(b). Recombinant human bone morphogenetic protein (rhBMP-2) is a member of a family of cytokines capable of inducing bone formation. It is produced from genetically modified cell lines using molecular cloning techniques. Use of rhBMP-2 in the cervical spine may carry a risk of swelling and ectopic bone formation which can encroach on neurovascular structures and on the esophagus. BMP usage in the anterior cervical spine is generally not indicated.

v. Post-Operative Treatment. Cervical bracing may be appropriate (usually 6-12 weeks with fusion). Home programs with instruction in ADLs, sitting, posture, and a daily walking program should be an early part of the rehabilitation process. Referral to a formal rehabilitation program, with emphasis on cervical, scapular, and thoracic strengthening, and restoration of ROM, is appropriate once the fusion is solid and without complication. Active treatment, which patients should have had prior to surgery, will frequently require a repeat of the sessions previously ordered. The goals of the therapy program should include instruction in a long-term home-based exercise program. (Refer to Active Therapy).

2. Disc herniation and other cervical conditions. Operative treatment is indicated only when the natural history of an operatively treatable problem is better than the natural history of the problem without operative treatment. All patients being considered for surgical intervention should undergo a comprehensive neuromuscular examination to identify pain generators that may respond to nonsurgical techniques or may be refractory to surgical intervention. Timely decision making for operative intervention is critical to avoid deconditioning, and increased disability of the cervical spine.

a. General Recommendations. There is some evidence to suggest that recovery from cervical radiculopathy in patients without clinical signs of spinal cord compression at one year is similar with one-level fusion, physical therapy, or rigid cervical collar use. For patients with whiplash injury (Quebec Classification Grade Levels I or II), there is no evidence of any beneficial effect of operative treatment. Refer to (Soft Tissue Injury Evaluation), for Discussion on Quebec Classification Levels.

b. If cervical fusion is being considered, it is recommended that the injured worker refrain from smoking for at least six weeks prior to surgery and during the time of healing. Because smokers have a higher risk of non-union and higher post-operative costs, it is recommended that insurers cover a smoking cessation program peri-operatively.

c. General indications for surgery. operative intervention should be considered and a consultation obtained when improvement of symptoms has plateaued and the residual symptoms of pain and functional disability are unacceptable at the end of six weeks of treatment, or at the

end of longer duration of non-operative intervention for debilitated patients with complex problems. Choice of hardware instrumentation is based on anatomy, the patient's pathology, and surgeon's experience and preference.

i. Specific indications include:

(a). for patients with myelopathy immediate surgical evaluation and treatment is indicated;

(b). for patients with cervical radiculopathy:

(i). early intervention may be required for acute incapacitating pain or in the presence of progressive neurological deficits;

(ii). persistent or recurrent arm pain with functional limitations, unresponsive to conservative treatment after six weeks; or

(iii). progressive functional neurological deficit; or

(iv). static neurological deficit associated with significant radicular pain; and

(v). confirmatory imaging studies consistent with clinical findings;

(c). for patients with persistent non-radicular cervical pain: in the absence of a radiculopathy, it is recommended that a decisive commitment to surgical or nonsurgical interventions be made within four to five months following injury. The effectiveness of three-level cervical fusion for non-radicular pain has not been established. In patients with non-radicular cervical pain for whom fusion is being considered, required pre-operative indications include all of the following.

(i). In general, if the program of non-operative treatment fails, operative treatment is indicated when:

[a]. improvement of the symptoms has plateaued, and the residual symptoms of pain and functional disability are unacceptable at the end of 6 to 12 weeks of active treatment, or at the end of longer duration of non-operative programs for debilitated patients with complex problems; and/or

[b]. frequent recurrences of symptoms cause serious functional limitations even if a non-operative active treatment program provides satisfactory relief of symptoms, and restoration of function on each recurrence;

[c]. mere passage of time with poorly guided treatment is not considered an active treatment program;

(ii). all pain generators are adequately defined and treated; and

(iii). all physical medicine and manual therapy interventions are completed; and

(iv). x-ray, MRI, or CT/discography demonstrating disc pathology or spinal instability; and

- (v). spine pathology limited to two levels; and
- (vi). psychosocial evaluation for confounding issues addressed;
- (vii). for any potential surgery, it is recommended that the injured worker refrain from smoking for at least six weeks prior to surgery and during the period of healing. Because smokers have a higher risk of non-union and higher post-operative costs, it is recommended that insurers cover a smoking cessation program peri-operatively.

ii. Surgical procedures include:

(a). Cervical Discectomy with or without Fusion

(i). Description. Procedure to relieve pressure on one or more nerve roots or spinal cord. It may be performed with or without the use of a microscope.

(ii). Complications. Appropriate medical disclosures should be provided to the patient as deemed necessary by the treating physician.

(iii). Surgical Indications. Radiculopathy from ruptured disc or spondylosis, spinal instability, or patients with non-radicular neck pain meeting fusion criteria. There is no evidence that discectomy with fusion versus discectomy without fusion has superior long-term results. Discectomy alone is generally considered in patients with pure radicular symptoms from their herniated disc and who have sufficiently large foramen that disc space collapse is unlikely to further compromise the nerve root. Failure rates increase with disease at more than two levels.

(iv). Operative Treatment. Cervical plating may be used to prevent graft dislodgment especially for multi-level disease.

[a]. Recombinant Human Bone Morphogenetic Protein (rhBMP-2) is a member of a family of cytokines capable of inducing bone formation. It is produced from genetically modified cell lines using molecular cloning techniques. Use of rhBMP-2 in the cervical spine may carry a risk of swelling and ectopic bone formation which can encroach on neurovascular structures and on the esophagus. BMP usage in the anterior cervical spine is generally not indicated.

(v). Post-Operative Therapy. Cervical bracing may be appropriate (usually 6 - 12 weeks with fusion). Home programs with instruction in ADLs, sitting, posture, and a daily walking program should be an early part of the rehabilitation process. Referral to a formal rehabilitation program, with emphasis on cervical, scapular, and thoracic strengthening and restoration of ROM is appropriate, once fusion is solid and without complication. Active treatment, which patients should have had prior to surgery, will frequently require a repeat of the sessions previously ordered. The goals of the therapy program should include instruction in a long-term home-based exercise program. (Refer to Active Therapy).

(b). Cervical Corpectomy

(i). Description. Removal of a portion or the entire vertebral body from the front of the spine. May also include removal of the adjacent discs. Usually involves fusion.

(ii). Complications. Appropriate medical disclosures should be provided to the patient as deemed necessary by the treating physician.

(iii). Surgical Indications. Single or two-level spinal stenosis, spondylolisthesis, or severe kyphosis, with cord compression.

(iv). Operative Treatment. Neural decompression, fusion with instrumentation, or halo vest placement to maintain cervical position. Hemisectorpomy may be done when only a portion of the vertebral body needs to be resected. Allografts may be used for single bone graft fusion; however, autografts are generally preferable for multi-level fusions unless a large strut graft is required.

(v). Post-Operative Therapy—dependent upon number of vertebral bodies involved, healing time may be longer than discectomy. Halo vest care is required. Home programs with instruction in ADLs, sitting, posture, and a daily walking program should be an early part of the rehabilitation process. Referral to a formal rehabilitation program with emphasis on cervical, scapular, and thoracic strengthening is appropriate for most patients once the cervical spine is deemed stable and without complication. The goals of the therapy program should include instruction in a long-term home-based exercise program. (Refer to Active Therapy).

(c). Cervical Laminectomy with or without Foraminotomy or Fusion:

(i). Description. Surgical removal of the posterior portion of a vertebrae in order to gain access to the spinal cord or nerve roots with or without stabilization fusion. /instrumentation.

(ii). Complications. May include perineural fibrosis, kyphosis in fractures without fusion or with failed fusion, nerve injury, post surgical instability (with foraminotomies), CSF leak, infection, in-hospital mortality, non-union of fusion, donor site pain (autograft only).

(iii). Surgical Indications. Neural compression.

(iv). Operative Treatment. Laminotomy, partial discectomy, and nerve root decompression.

(v). Post-Operative Therapy. Cervical bracing may be appropriate (usually 6 to 12 weeks with fusion). Home programs with instruction in ADLs, sitting, posture, and a daily walking program should be an early part of the rehabilitation process. Referral to a formal rehabilitation program with emphasis on cervical, scapular, and thoracic strengthening and restoration of ROM is appropriate for most patients once the cervical spine is deemed stable and without complication. The goals of the therapy program should include instruction in a long-term home-based exercise program. (Refer to Active Therapy).



## (d). Cervical Laminoplasty

(i). Description. Technique that increases anterior or posterior dimensions of the spinal canal while leaving posterior elements partially intact. It may be performed with or without the use of a microscope.

(ii). Complications. Loss of cervical motion, especially extension.

(iii).Surgical Indications. Multi-level disease: cervical spinal stenosis or spondylitic myelopathy. Not indicated in cervical kyphosis.

(iv).Operative Treatment. Posterior approach, with or without instrumentation.

(v). Post-Operative Therapy. May include 4 to 12 weeks of cervical bracing. Home programs with instruction in ADLs, sitting, posture, and daily walking program should be an early part of the rehabilitation process. Referral to a formal rehabilitation program with emphasis on cervical, scapular, and thoracic strengthening and restoration of ROM is appropriate once the cervical spine is stable and without complication. Active treatment which patients should have had prior to surgery will frequently require a repeat of the sessions previously ordered. The goals of the therapy program should include instruction in a long-term, home-based exercise program. (Refer to Active Therapy).

## (e). Percutaneous Discectomy:

(i). Description. An invasive operative procedure to accomplish partial removal of the disc through a needle which allows aspiration of a portion of the disc trocar under imaging control.

(ii). Complications include, but are not limited to, injuries to the nerve or vessel, infection, and hematoma.

(iii).Surgical Indications. Percutaneous discectomy is indicated only in cases of suspected septic discitis in order to obtain diagnostic tissue. The procedure is not recommended for contained disc herniations or bulges with associated radiculopathy due to lack of evidence to support long-term improvement.

## (iv).Operative Treatment: Partial Discectomy

3. Artificial Cervical Disc Replacement. This involves the insertion of an FDA approved prosthetic device into the cervical intervertebral space with the goal of maintaining physiologic motion at the treated cervical segment. The use of artificial discs in motion-preserving technology should be based on the surgeon's skill and training. Artificial disc replacement has been found to be efficacious for both one and two level arthroplasty.

4. Percutaneous radiofrequency disc decompression of the cervical spine is an investigational procedure which introduces a 19 gauge cannula under local anesthesia and fluoroscopic guidance into the nucleus pulposus of a contained herniated disc, using radiofrequency energy to dissolve and remove disc material. Pressure inside the disc is lowered as a result. There have been no randomized clinical trials of this procedure at this time. It is not recommended.

5. Epiduroscopy and Epidural Lysis of Adhesions. Refer to Therapeutic Injections.

6. Intraoperative neurophysiologic monitoring (IONM) is a battery of neurophysiologic tests used to assess the functional integrity of the spinal cord, nerve roots, and other peripheral nervous system structures (eg, brachial plexus) during spinal surgery. The underlying principle of IONM is to identify emerging insult to nervous system structures, pathways, and/or related vascular supply and to provide feedback regarding correlative changes in neural function before development of irreversible neural injury. IONM data provide an opportunity for intervention to prevent or minimize postoperative neurologic deficit. Current multimodality monitoring techniques permit intraoperative assessment of the functional integrity of afferent dorsal sensory spinal cord tracts, efferent ventral spinal cord motor tracts, and nerve roots. Combined use of these techniques is useful during complex spinal surgery because these monitoring modalities provide important complementary information to the surgery team. Intraoperative neurophysiologic monitoring should be used during spinal surgery when information regarding spinal cord and nerve root function is desired. The appropriate diagnostic modality for the proposed surgical intervention should be utilized at the discretion of the surgeon.

7. Non invasive electrical bone growth stimulators may be considered:

a. as an adjunct to becomespinal fusion surgery for those at high risk for pseudoarthrosis, including one or more of the following fusion failure risk factors:

- i. one or more previous failed spinal fusion(s);
- ii. grade ii or worse spondylolisthesis;
- iii. fusion to be performed at more than one level;
- iv. presence of other risk factors that may contribute to non-healing:

(a). current smoking;

(b). diabetes;

(c). renal disease;

(d). other metabolic diseases where bone healing is likely to be compromised (e.g.: significant osteoporosis);

(e). active alcoholism;

(f). common Morbid obesity BMI >40;

b. as treatment for individuals with failed spinal fusion. Failed spinal fusion is defined as percutaneous spinal procedures gain greater acceptance.a spinal fusion that has not healed at a minimum of 6 months after the original surgery, as evidenced by serial x-rays over a course of 3 months during the latter portion of the 6 month period;

c. no strict criteria for device removal are suggested in the literature. Implanted devices are generally removed only when the patient complains of discomfort, when there is device malfunction, or to allow for future ability to use

MRI. Removal of batteries is not recommended unless there is a device malfunction or other complication.

**AUTHORITY NOTE:** Promulgated in accordance with R.S. 23:1203.1.

**HISTORICAL NOTE:** Promulgated by the Louisiana Workforce Commission, Office of Workers Compensation Administration, LR 37:1651 (June 2011), amended by the Louisiana Workforce Commission, Office of Workers Compensation, LR 40:1132 (June 2014), LR 49:519 (March 2023).

## Subchapter B. Low Back Pain

Editor's Note: Form LWC-WC 1009. Disputed Claim for Medical Treatment has been moved to §2328 of this Part.

### §2013. Introduction

A. This document has been prepared by the Louisiana Workforce Commission, Office of Workers' Compensation (OWCA) and should be interpreted within the context of guidelines for physicians/providers treating individuals qualifying under Louisiana Workers' Compensation Act as injured workers with low back pain. Although the primary purpose of this document is advisory and educational, the guidelines are enforceable under the Louisiana Workers Compensation Act. All medical care, services, and treatment owed by the employer to the employee in accordance with the Louisiana Workers' Compensation Act shall mean care, services, and treatment in accordance with these guidelines. Medical care, services, and treatment that varies from these guidelines shall also be due by the employer when it is demonstrated to the medical director of the office by a preponderance of the scientific medical evidence, that a variance from these guidelines is reasonably required to cure or relieve the injured worker from the effects of the injury or occupational disease given the circumstances. Therefore, these guidelines are not relevant as evidence of a provider's legal standard of professional care. To properly utilize this document, the reader should not skip nor overlook any sections.

**AUTHORITY NOTE:** Promulgated in accordance with R.S. 23:1203.1.

**HISTORICAL NOTE:** Promulgated by the Louisiana Workforce Commission, Office of Workers Compensation Administration, LR 37:1655 (June 2011), amended LR 46:1244 (September 2020).

### §2015. General Guideline Principles

A. The principles summarized in this section are key to the intended implementation of all Office of Workers' Compensation medical treatment guidelines and critical to the reader's application of the guidelines in this document.

1. **Application of Guidelines.** The OWCA provides procedures to implement medical treatment guidelines and to foster communication to resolve disputes among the provider, payer, and patient through the Workers Compensation Act.

2. **Education.** Education of the patient and family, as well as the employer, insurer, policy makers and the community should be the primary emphasis in the treatment of workers' compensation injuries. Currently, practitioners often think of education last, after medications, manual

therapy, and surgery. Practitioners must develop and implement strategies to educate patients, employers, insurance systems, policy makers, and the community as a whole. An education-based paradigm should always start with inexpensive communication providing reassuring and evidence-based information to the patient. More in-depth education is currently a component of treatment regimens which employ functional, restorative, preventive and rehabilitative programs. No treatment plan is complete without addressing issues of individual and/or group patient education as a means of facilitating self-management of symptoms and prevention. Facilitation through language interpretation, when necessary, is a priority and part of the medical care treatment protocol.

3. **Informed Decision Making.** Providers should implement informed decision making as a crucial element of a successful treatment plan. Patients, with the assistance of their health care practitioner, should identify their personal and professional functional goals of treatment at the first visit. Progress towards the individual's identified functional goals should be addressed by all members of the health care team at subsequent visits and throughout the established treatment plan. Nurse case managers, physical therapists, and other members of the health care team play an integral role in informed decision-making and achievement of functional goals. Patient education and informed decision-making should facilitate self-management of symptoms and prevention of further injury.

4. **Treatment Parameter Duration—**time frames for specific interventions commence once treatments have been initiated, not on the date of injury. Obviously, duration will be impacted by patient adherence, as well as availability of services. Clinical judgment may substantiate the need to accelerate or decelerate the time frames discussed in this document. Such deviation shall be in accordance with La. R.S. 23:1203.1.

5. **Active interventions emphasizing patient responsibility,** such as therapeutic exercise and/or functional treatment, are generally emphasized over passive modalities, especially as treatment progresses. Generally, passive interventions are viewed as a means to facilitate progress in an active rehabilitation program with concomitant attainment of objective functional gains.

6. **Active Therapeutic Exercise Program.** Exercise program goals should incorporate patient strength, endurance, flexibility, coordination, and education. This includes functional application in vocational or community settings.

7. **Positive Patient Response.** Positive results are defined primarily as functional gains that can be objectively measured.

a. **Objective functional gains** include, but are not limited to, positional tolerances, range-of-motion (ROM), strength, and endurance, activities of daily living, ability to function at work, cognition, psychological behavior, and efficiency/velocity measures that can be quantified. Subjective reports of pain and function should be considered

and given relative weight when the pain has anatomic and physiologic correlation. Anatomic correlation must be based on objective findings.

8. Re-Evaluation of Treatment within Four Weeks. If a given treatment or modality is not producing positive results within four weeks, treatment should be either modified or discontinued. Reconsideration of diagnosis should also occur in the event of poor response to a seemingly rational intervention.

9. Surgical Interventions. Surgery should be contemplated within the context of expected improvement of functional outcome and not purely for the purpose of pain relief. The concept of "cure" with respect to surgical treatment by itself is generally a misnomer. All operative interventions must be based upon positive correlation of clinical findings, clinical course, and diagnostic tests. A comprehensive assimilation of these factors must lead to a specific diagnosis with positive identification of pathologic conditions. The decision and recommendation for operative treatment, and the appropriate informed consent should be made by the operating surgeon. Prior to surgical intervention, the patient and treating physician should identify functional operative goals and the likelihood of achieving improved ability to perform activities of daily living or work activities and the patient should agree to comply with the pre- and post-operative treatment plan and home exercise requirements. The patient should understand the length of partial and full disability expected post-operatively.

10. Pharmacy Louisiana Law and Regulation. All prescribing will be done in accordance with the laws of the state of Louisiana as they pertain respectively to each individual licensee, including, but not limited to: Louisiana State Board of Medical Examiners regulations governing medications used in the treatment of non-cancer-related chronic or intractable pain; Louisiana Board of Pharmacy Prescription Monitoring Program; Louisiana Department of Health and Hospitals licensing and certification standards for pain management clinics; other laws and regulations affecting the prescribing and dispensing of medications in the state of Louisiana.

11. Six Month Time Frame. Injuries resulting in temporary total disability may require maintenance treatment and may not attain return to work in six months.

12. Return to Work. Return to work is therapeutic, assuming the work is not likely to aggravate the basic problem or increase long-term pain. An injured worker's return-to-work status shall not be the sole cause to deny reasonable and medically necessary treatment under these guidelines. Two good practices are: early contact with injured workers and provide modified work positions for short-term injuries. The practitioner must provide specific physical limitations and the patient should never be released to non-specific and vague descriptions such as "sedentary" or "light duty." The following physical limitations should be considered and modified as recommended: lifting, pushing, pulling, crouching, walking, using stairs, bending at the

waist, awkward and/or sustained postures, tolerance for sitting or standing, hot and cold environments, data entry and other repetitive motion tasks, sustained grip, tool usage and vibration factors. Even if there is residual chronic pain, return-to-work is not necessarily contraindicated. The practitioner should understand all of the physical demands of the patient's job position before returning the patient to full duty and should request clarification of the patient's job duties. Clarification should be obtained from the employer or, if necessary, from including, but not limited to, occupational health nurse, physical therapist, occupational therapist, vocational rehabilitation specialist, an industrial hygienist, chiropractor or another professional. American Medical Association clarifies "disability" as "activity limitations and/or participation restrictions in an individual with a health condition, disorder or disease" versus "impairment" as "a significant deviation, loss, or loss of use of any body structure or body function in an individual with a health condition, disorder or disease".

13. Delayed Recovery. Within the discretion of the treating physician, strongly consider a psychological evaluation, if not previously provided, as well as initiating interdisciplinary rehabilitation treatment and vocational goal setting, for those patients who are failing to make expected progress 6 to 12 weeks after initiation of treatment of an injury. The OWCA recognizes that 3 to 10 percent of all industrially injured patients will not recover within the timelines outlined in this document despite optimal care. Such individuals may require treatments beyond the limits discussed within this document, but such treatment requires clear documentation by the authorized treating practitioner focusing on objective functional gains afforded by further treatment and impact upon prognosis.

14. Guideline Recommendations and Inclusion of Medical Evidence. All recommendations are based on available evidence and/or consensus judgment. It is generally recognized that early reports of a positive treatment effect are frequently weakened or overturned by subsequent research. Per R.S. 1203.1, when interpreting medical evidence statements in the guideline, the following apply to the strength of recommendation.

Strong	Level 1 Evidence	We Recommend
Moderate	Level 2 and Level 3 Evidence	We Suggest
Weak	Level 4 Evidence	Treatment is an Option
Inconclusive	Evidence is Either Insufficient or Conflicting	

15. Treatment of Pre-Existing Conditions The conditions that preexisted the work injury/disease will need to be managed under two circumstances: (a) A pre-existing condition exacerbated by a work injury/disease should be treated until the patient has returned to their objectively verified prior level of functioning or Maximum Medical Improvement (MMI); and (b) A pre-existing condition not directly caused by a work injury/disease but which may prevent recovery from that injury should be treated until its objectively verified negative impact has been controlled. The focus of treatment should remain on the work injury/disease.

a. Consensus guidelines are generated by a professional organization that the guidelines are intended to serve. A committee of specialists and experts are selected by the organization to create an unbiased, vetted recommendation for the treatment of specific issues within the realm of their expertise. All recommendations in the guideline are considered to represent reasonable care in appropriately selected cases, regardless of the level of evidence or consensus statement attached to it. Those procedures considered inappropriate, unreasonable, or unnecessary are designated in the guideline as “not recommended.”

B. The remainder of this document should be interpreted within the parameters of these guideline principles that may lead to more optimal medical and functional outcomes for injured workers.

AUTHORITY NOTE: Promulgated in accordance with R.S. 23:1203.1.

HISTORICAL NOTE: Promulgated by the Louisiana Workforce Commission, Office of Workers Compensation Administration, LR 37:1655 (June 2011), amended by the Louisiana Workforce Commission, Office of Workers Compensation, LR 40:1135 (June 2014), LR 46:1244 (September 2020).

**§2017. Initial Diagnostic Procedures**

A. The OWCA recommends the following diagnostic procedures be considered, at least initially, the responsibility of the workers’ compensation carrier to ensure that an accurate diagnosis and treatment plan can be established. Standard procedures, that should be utilized when initially diagnosing a work-related low back pain complaint, are listed below.

1. History-taking and physical examination (Hx and PE) are generally accepted, well-established and widely used procedures that establish the foundation/basis for and dictates subsequent stages of diagnostic and therapeutic procedures. List of medications patient is taking should be included in every history, including over the counter medicines as well as supplements. When findings of clinical evaluations and those of other diagnostic procedures are not complementing each other, the objective clinical findings should have preference. The medical records should reasonably document the following.

a. History of Present Injury—a detailed history, taken in temporal proximity to the time of injury should primarily guide evaluation and treatment. The history should include pertinent positive and negative information regarding the following:

i. mechanism of injury. This includes details of symptom onset and progression. The mechanism of injury should include a detailed description of the incident and the position of the body before, during, and at the end of the incident. Inclusion of normal work body postures, frequency during the workday, and lifting/push/pull requirements should be included in the absence of a known specific incident;

ii. location of pain, nature of symptoms, and alleviating/exacerbating factors (e.g., sitting tolerance). The history should include both the primary and secondary complaints (e.g., primary low back pain, secondary hip, groin). The use of a patient completed pain drawing, such as Visual Analog Scale (VAS), is highly recommended, especially during the first two weeks following injury to assure that all work related symptoms are addressed;

iii. presence and distribution of lower extremity numbness, paresthesias, or weakness, especially if precipitated by coughing or sneezing;

iv. alteration in bowel, bladder, or sexual function; and for female patients, alteration in their menstrual cycle;

v. any treatment for current injuries or results;

vi. ability to perform job duties and activities of daily living.

b. Past History

i. past medical history includes neoplasm, gout, arthritis, hypertension, kidney stones, and diabetes;

ii. review of systems includes symptoms of rheumatologic, neurologic, endocrine, neoplastic, infectious, and other systemic diseases;

iii. smoking history;

iv. vocational and recreational pursuits;

v. history of depression, anxiety, or other psychiatric illness; and

vi. prior occupational and non-occupational injuries to the same area including specific prior treatment, chronic or recurrent symptoms, and any functional limitations; specific history regarding prior motor vehicle accidents may be helpful.

c. Physical Examination—should include accepted tests and exam techniques applicable to the area being examined, including:

i. general and visual inspection, including posture, stance, balance and gait;

ii. palpation of spinous processes, facets, and pelvis; and muscles noting myofascial tightness, tenderness and trigger points

iii. lumbar range of motion, and quality of motion, and presence of muscle spasm. Motion evaluation of specific joints may be indicated;

iv. examination of thoracic spine and pelvis;

v. nerve tension testing;

vi. sensory and motor examination of the lower extremities with specific nerve root focus;

vii. deep tendon reflexes with or without Babinski’s;

viii. if applicable to injury, anal sphincter tone and/or perianal sensation; and

ix. if applicable, abdominal examination, vascular examination, circumferential lower extremity measurements, or evaluation of hip or other lower extremity abnormalities;

x. if applicable, Waddell Signs, which include five categories of clinical signs tenderness; superficial and non-anatomic, pain with simulation: axial loading and rotation; regional findings: sensory and motor, inconsistent with nerve root patterns; distraction/inconsistency in straight leg raising findings, and over-reaction to physical examination maneuvers. Significance may be attached to positive findings in three out of five of these categories, but not to isolated findings. Waddell advocates considering Waddell's signs prior to recommending a surgical procedure. These signs should be measured routinely to identify patients requiring further assessment (i.e., biopsychosocial) prior to undergoing back surgery.

(a). It is generally agreed that Waddell Signs are associated with decreased functional performance and greater subjective pain levels, though they provide no information on the etiology of pain. Waddell Signs cannot be used to predict or diagnose malingering. Their presence of three out of five signs may most appropriately be viewed as a "yellow flag", or screening test, alerting clinicians to those patients who require a more comprehensive approach to their assessment and care plan. Therefore, if three out of five Waddell Signs are positive in a patient with subacute or chronic back pain, a psychosocial evaluation should be part of the total evaluation of the patient. Refer to Personality/Psychological/Psychosocial Evaluation.

d. Relationship to Work. This includes a statement of the probability that the illness or injury is work-related. If further information is necessary to determine work relatedness, the physician should clearly state what additional diagnostic studies or job information is required.

2. Radiographic imaging of the lumbosacral spine is a generally accepted, well-established and widely used diagnostic procedure when specific indications based on history and/or physical examination are present. There is some evidence that early radiographic imaging without clear indications is associated with prolonged care, but no difference in functional outcomes. Therefore, it should not be routinely performed without indications. The mechanism of injury and specific indications for the radiograph should be listed on the request form to aid the radiologist and x-ray technician. Suggested indications include:

a. history of significant trauma, especially blunt trauma or fall from a height; greater than one meter; high impact motor vehicle accident, rollover, ejection, bicycle, or recreational vehicle collision; seatbelt use;

b. age over 55 years;

c. unexplained or persistent low back pain for at least 6 weeks or pain that is worse with rest;

d. localized pain, fever, constitutional symptoms, or history or exam suggestive of intravenous drug abuse, prolonged steroid use, or osteomyelitis;

e. suspected lesion in the lumbosacral spine due to systemic illness such as a rheumatic/rheumatoid disorder or endocrinopathy. Suspected lesions may require special views;

f. past medical history suggestive of pre-existing spinal disease, osteoporosis, spinal instrumentation, or cancer; and

g. prior to high-velocity/low amplitude manipulation or Grade IV to V mobilization.

3. Laboratory Testing. Laboratory tests are generally accepted, well-established and widely used procedures. They are, however, rarely indicated at the time of initial evaluation, unless there is suspicion of systemic illness, infection, neoplasia, or underlying rheumatologic disorder, connective tissue disorder, or based on history and/or physical examination. Laboratory tests can provide useful diagnostic information. Tests include, but are not limited to:

a. complete blood count (CBC) with differential can detect infection, blood dyscrasias, and medication side effects;

b. erythrocyte sedimentation rate (ESR), rheumatoid factor (RF), antinuclear antigen (ANA), human leukocyte antigen (HLA), and C-reactive protein (CRP), can be used to detect evidence of a rheumatologic, infectious, or connective tissue disorder;

c. serum calcium, phosphorous, uric acid, alkaline phosphatase, and acid phosphatase can detect metabolic bone disease;

d. urinalysis for bacteria (usually with culture and sensitivity), calcium, phosphorus, hydroxyproline, or hematuria; and

e. liver and kidney function may be performed for prolonged anti-inflammatory use or other medications requiring monitoring.

AUTHORITY NOTE: Promulgated in accordance with R.S. 23:1203.1.

HISTORICAL NOTE: Promulgated by the Louisiana Workforce Commission, Office of Workers Compensation Administration, LR 37:1656 (June 2011), amended by the Louisiana Workforce Commission, Office of Workers Compensation, LR 40:1136 (June 2014), LR 46:1245 (September 2020).

### **§2019. Follow-Up Diagnostic Imaging and Testing Procedures**

A. One diagnostic imaging or testing procedure may provide the same or distinctive information as does another procedure. Therefore, prudent choice of a single diagnostic procedure, a complement of procedures, or a sequence of procedures will optimize diagnostic accuracy; and maximize cost effectiveness (by avoiding redundancy), and minimize potential adverse effects to patients. All imaging and testing procedures have a degree of specificity and sensitivity for

various diagnoses. No isolated imaging test can assure a correct diagnosis.

B. Clinical information obtained by history taking and physical examination should form the basis for selecting an imaging procedure and interpreting its results. Clinical updates must demonstrate the patient's current status to document the need for diagnostic testing or additional treatment. A brief history, changes in clinical findings such as orthopedic and neurological tests, and measurements of function with emphasis on the current, specific physical limitations will be important when seeking approval of future care. The emphasis of the medical treatment schedule are that the determination of the need to continue treatment is based on functional improvement, and that the patient's ability (current capacity) to return to work is needed to assist in disability management.

C. Magnetic resonance imaging (MRI), myelography, or computed axial tomography (CT) scanning following myelography, and other imaging procedures and testing may provide useful information for many spinal disorders. When a diagnostic procedure, in conjunction with clinical information, can provide sufficient information to establish an accurate diagnosis, the second diagnostic procedure will become a redundant procedure. At the same time, a subsequent diagnostic procedure can be a complementary diagnostic procedure if the first or preceding procedures, in conjunction with clinical information, cannot provide an accurate diagnosis. Usually, preference of a procedure over others depends upon availability, a patient's tolerance, and/or the treating practitioner's familiarity with the procedure. Subsequent MRI may be indicated with a change in neurological exam, change in symptoms or a contemplated surgical intervention.

1. Imaging studies are generally accepted, well-established and widely used diagnostic procedures. In the absence of myelopathy, or neurological changes, or history of cancer, imaging usually is not appropriate until conservative therapy has been tried and failed. Six to eight weeks of treatment are usually an adequate period of time before an imaging procedure is in order, but the clinician should use judgment in this regard. When indicated, imaging studies can be utilized for further evaluation of the low back, based upon the mechanism of injury, symptoms, and patient history. Prudent choice of a single diagnostic procedure, a complementary combination of procedures, or a proper sequential order of complementary procedures will help ensure maximum diagnostic accuracy and minimize adverse effect to the patient. When the findings of the diagnostic imaging and testing procedures are not consistent with the clinical examination, the clinical findings should have preference. There is good evidence that in the asymptomatic population, disc bulges, annular tears, or high intensity zone areas, and disc height loss are prevalent 40 to 60 percent of the time depending on the condition, study, and age of the patient. Therefore, the existence of these anatomic findings should not be considered relevant without physiologic and clinical correlation in an individual patient. The studies below are listed in frequency of use, not importance:

a. Magnetic Resonance Imaging (MRI) is rarely indicated in patients with non-traumatic acute low back pain with no neuropathic signs or symptoms. It is generally the first follow-up imaging study in individuals who respond poorly to proper initial conservative care. MRI is useful in suspected nerve root compression, myelopathy, masses, infections, metastatic disease, disc herniation, annular tear, and cord contusion or severe incapacitating pain. MRI is contraindicated in patients with certain implants.

i. In general, the high field, conventional, MRI provides better resolution. A lower field scan may be indicated when a patient cannot fit into a high field scanner or who is too claustrophobic despite sedation. Inadequate resolution on the first scan may require a second MRI using a different technique. All questions in this regard should be discussed with the MRI center and/or radiologist.

ii. Specialized MRI Scans

(a). MRI with three-dimensional reconstruction. On rare occasions, MRI with three-dimensional reconstruction views may be used as a pre-surgical diagnostic procedure to obtain accurate information of characteristics, location, and spatial relationships among soft tissue and bony structures.

(b). Dynamic-kinetic MRI of the spine. Dynamic-kinetic MRI of the spine uses an MRI unit configured with a top-front open design which enables upright, weight-bearing patient positioning in a variety of postures not obtainable with the recumbent images derived from conventional, closed unit MRI systems. Imaging can be obtained in flexion, extension, and rotation of the spine, as well as in erect positioning. There is a theoretical advantage to imaging sequences obtained under more physiologic conditions than in the supine position. There is currently ongoing research to establish whether the theoretical advantages of positional and kinetic MRI result in improved sensitivity and specificity in detecting spine pathology. Currently it remains investigational and is not recommended until the correlation with clinical syndromes and outcomes is firmly established.

b. Computed Axial Tomography (CT) provides excellent visualization of bone and is used to further evaluate bony masses and suspected fractures not clearly identified on radiographic evaluation. It may sometimes be done as a complement to MRI scanning to better delineate bony osteophyte formation in the neural foramen. Instrument-scatter reduction software provides better resolution when metallic artifact is of concern.

c. Post-Fusion Patients—monitoring of fusion can be done with initial x-rays within the first few weeks after surgery. Then, x-rays every three months up to a year. CT scan or X-rays can be done at one year to assess for fusion.

d. Myelography is the injection of radiopaque material into the spinal subarachnoid space, with x-rays then taken to define anatomy. It may be used as a diagnostic procedure to obtain accurate information of characteristics, location, and spatial relationships among soft tissue and

bony structures. Myelography is an invasive procedure with complications including nausea, vomiting, headache, convulsion, arachnoiditis, cerebral-spinal fluid (CSF) leakage, allergic reactions, bleeding, and infection. Therefore, myelography should only be considered when CT and MRI are unavailable, for morbidly obese patients or those who have undergone multiple operations, and when other tests prove non-diagnostic. The use of small needles and a less toxic, water-soluble, nonionic contrast is recommended.

e. CT Myelogram provides more detailed information about relationships between neural elements and surrounding anatomy and is appropriate in patients with multiple prior operations or tumorous conditions.

f. Single Photon Emission Computerized Tomography (SPECT). A scanning technique which may be helpful to localize facet joint pathology and is useful in determining which patients are likely to have a response to facet injection. SPECT combines bone scans & CT Scans in looking for facet joint pathology.

g. Bone Scan (Radioisotope Bone Scanning) is generally accepted, well-established, and widely used. Bone scanning is more sensitive but less specific than MRI. 99mTechnetium diphosphonate uptake reflects osteoblastic activity and may be useful in diagnosing metastatic/primary bone tumors, stress fractures, osteomyelitis, and inflammatory lesions, but cannot distinguish between these entities.

h. Other Radioisotope Scanning: Indium and gallium scans are generally accepted, well-established, and widely used procedures usually to help diagnose lesions seen on other diagnostic imaging studies. 67Gallium citrate scans are used to localize tumor, infection, and abscesses. 111Indium-labeled leukocyte scanning is utilized for localizing infection or inflammation.

i. Dynamic [Digital] Fluoroscopy: Dynamic [Digital] Fluoroscopy of the lumbar spine measures the motion of intervertebral segments using a videofluoroscopy unit to capture images as the subject performs lumbar flexion and extension, storing the anatomic motion of the spine in a computer. Currently it is not recommended for use in the diagnosis of lumbar instability, since there is limited information on normal segmental motion for the age groups commonly presenting with low back pain, and diagnostic criteria for specific spinal conditions are not yet defined. No studies have yet demonstrated predictive value in terms of standard operative and non-operative therapeutic outcomes.

2. Other Tests. The following diagnostic procedures in this subsection are listed in alphabetical order, not by importance:

a. Electrodiagnostic Testing

i. Electromyography (EMG), Nerve Conduction Studies (NCS) These are generally accepted, well-established and widely used diagnostic procedures. EMG and NCS, when performed and interpreted by a trained physician/electrophysiologist, may be useful for patients

with suspected neural involvement whose symptoms are persistent or unresponsive to initial conservative treatments. They are used to differentiate peripheral neural deficits from radicular and spinal cord neural deficits and to rule out concomitant myopathy. However, F-Wave Latencies are not diagnostic for radiculopathy.

(a). In general, EMG and NCS are complementary to imaging procedures such as CT, MRI, and/or myelography or diagnostic injection procedures. Electrodiagnostic studies may provide useful, correlative neuropathophysiological information that would be otherwise unobtainable from the radiologic studies discussed above.

ii. Portable Automated Electrodiagnostic Device (also known as Surface EMG) is not a substitute for conventional diagnostic testing in clinical decision-making, and therefore, is not recommended.

iii. Somatosensory Evoked Potential (SSEP) is not recommended to identify radiculopathy. It may be used to evaluate myelopathy and other rare neurological disorders such as neurogenic bladder and sexual dysfunction.

iv. Current Perception Threshold (CPT) Evaluation may be useful as a screening tool, but its diagnostic efficacy in the evaluation of industrial low back pain has not been determined. Therefore, CPT is not recommended as a diagnostic tool.

v. Large Array Surface Electromyography measures low back muscle activity using a fixed array of 63 electrodes arranged in nine rows and seven columns between the seventh thoracic spinous process and the iliac crest. The array simultaneously collects myoelectric data from multifidus, iliocostalis, quadratus lumborum, and other lumbar muscles, which is analyzed for patterns of activity in these muscle groups. It is used in researching physiologic changes and adaptations to back pain, but is not recommended as a diagnostic procedure for individuals with back pain due to a lack of interpretive standards.

vi. Surface EMG in combination with Range of Motion and/or Functional Capacity Evaluation. This is designed to detect differences between persons with and without low back pain, measuring signals in lumbar flexion which show that painful paraspinal muscles fail to relax fully. It may show aspects of the pathophysiology of muscle activity which advance the scientific understanding of low back pain. The test also purports to determine the significance of disc pathology and the age of an injury. It has not been evaluated in a setting which tests a spectrum of patients commonly seen in clinical practice, using an interpretation which is tested against a diagnostic reference standard. Therefore, it is not suitable as a diagnostic test for low back pain and its use for this purpose is not recommended.

b. Injections—Diagnostic

i. Spinal Diagnostic Injections. Diagnostic spinal injections are commonly used in patients and they usually have been performed previously in the acute or subacute

stage. They may rarely be necessary for aggravations of low back pain. Refer to the OWCA Low Back Pain Medical Treatment Guideline for indications.

ii. Diagnostic peripheral nerve blocks such as medial branch facet nerves (lumbar), sacral lateral branches of sacroiliac joints, selective nerve root blocks and transforaminal epidural injections and other pure sensory nerves suspected of causing pain, also include diagnostic facet joint injection as a diagnostic block. Images are required to be saved to verify needle placement.

iii. Medial branch facet blocks (lumbar, indicated if there is demonstration of tenderness over the facet joints or pain on the facet loading maneuvers,) and sacral lateral branch blocks, if provide 80 percent or more pain reduction as measured by a numerical pain index scale within one hour of the medial branch blocks up to three levels per side, then rhizotomy of the medial branch nerves, up to four nerves per side, may be done without confirmation block. If the initial set of medial branch blocks provides less than 80 percent but at least 50 percent pain reduction as measured by a numerical pain index scale or documented functional improvement, the medial branch block should be repeated for confirmation before a rhizotomy is performed. If 50 percent or greater pain reduction is achieved as measured by the NPIS with two sets of medial branch blocks for facet joint pain, then rhizotomy may be performed. Images are required to be saved to verify needle placement.

iv. In general, relief should last for at least the duration of the local anesthetic used and should significantly result in functional improvement and relief of pain. Refer to Injections-Spinal Therapeutic for information on other specific therapeutic injections.

(a). Description. Diagnostic spinal injections are generally accepted, well-established procedures. These injections may be useful for localizing the source of pain, and may have added therapeutic value when combined with injection of therapeutic medication(s). Each diagnostic injection has inherent risks, and risk versus benefit should always be evaluated when considering injection therapy.

(b). Indications. Since these procedures are invasive, less invasive or non-invasive procedures should be considered first. Selection of patients, choice of procedure, and localization of the level for injection should be determined by clinical information indicating strong suspicion for pathologic condition(s) and the source of pain symptoms. Because injections are invasive with an inherent risk, the number of diagnostic procedures should be limited in any individual patient to those most likely to be primary pain generators. Patients should not receive all of the diagnostic blocks listed merely in an attempt to identify 100 percent of the pain generators.

(c). The interpretation of the test results are primarily based on functional change, symptom report, and pain response (via a recognized pain scale), before and at an appropriate time period after the injection. The diagnostic significance of the test result should be evaluated in conjunction with clinical information and the results of other

diagnostic procedures. Injections with local anesthetics of differing duration may be used to support a diagnosis. In some cases, injections at multiple levels may be required to accurately diagnose low back pain.

(i). It is obligatory that sufficient data be accumulated by the examiner performing this procedure such that the diagnostic value of the procedure be evident to other reviewers. This entails, at a minimum, documentation of patient response immediately following the procedure with details of any symptoms with a response and the degree of response. Responses must be identified as to specific body part (e.g., low back, leg pain). The practitioner must identify the local anesthetic used and the expected duration of response for diagnostic purposes.

(ii). Multiple injections provided at the same session without staging may seriously dilute the diagnostic value of these procedures. Practitioners must carefully weigh the diagnostic value of the procedure against the possible therapeutic value.

(d). Special Requirements for Diagnostic Injections. Since multi-planar fluoroscopy during procedures is required to document technique and needle placement, an experienced physician should perform the procedure. Permanent images are required to verify needle placement. The subspecialty disciplines of the physicians performing the injections may be varied, including, but not limited to: anesthesiology, radiology, surgery, neurology or psychiatry. The practitioner should document hands-on training through workshops and/or completed fellowship training with interventional training. They must also be knowledgeable in radiation safety.

(e). Complications. General complications of diagnostic injections may include transient neurapraxia, nerve injury, infection, headache, urinary retention, and vasovagal effects, as well as epidural hematoma, permanent neurologic damage, dural perforation, and CSF leakage, and spinal meningeal abscess. Permanent paresis, anaphylaxis, and arachnoiditis have been rarely reported with the use of epidural steroids.

(f). Contraindications

(i). Absolute contraindications to diagnostic injections include: bacterial infection-systemic or localized to region of injection; bleeding diatheses; hematological conditions; and possible pregnancy;

(ii). Relative contraindications to diagnostic injections may include: allergy to contrast, poorly controlled diabetes mellitus and hypertension;

(iii). Drugs affecting coagulation may require restriction from use. Anti-platelet therapy and anti-coagulations should be addressed individually by a knowledgeable specialist. It is recommended to refer to the American Society of Regional Anesthesia for anticoagulation guidelines.

(g). Specific Diagnostic Injections. In general, relief should last for at least the duration of the local



anesthetic used and should significantly relieve pain and result in functional improvement. Refer to “Injections – Therapeutic” for information on specific therapeutic injections.

(i). Lumbar Medial Branch Facet Blocks and Sacral Lateral Branch Blocks. If the block provides 80 percent or more pain reduction as measured by a numerical pain index scale within one hour of the medial branch blocks up to three levels per side, then rhizotomy of the medial branch nerves, up to four nerves per side, may be done without confirmation block. If the initial set of medial branch blocks provides less than 80 percent but at least 50 percent pain reduction as measured by a numerical pain index scale or documented functional improvement, the medial branch block should be repeated for confirmation before a rhizotomy is performed. If 50 percent or greater pain reduction is achieved as measured by the NPIS with two sets of medial branch blocks for facet joint pain, then rhizotomy may be performed.

[a]. Frequency and Maximum Duration: May be repeated once for comparative blocks. Limited to four levels

(ii). Transforaminal injections/spinal selective nerve block (SSNB) are generally accepted and useful in identifying spinal pathology. When performed for diagnosis, small amounts of local anesthetic up to a total volume of 1.0 cc should be used to determine the level of nerve root irritation. A positive diagnostic block should result in a positive diagnostic functional benefit and a 50 percent reduction in nerve-root generated pain appropriate for the anesthetic used as measured by accepted pain scales (such as a VAS).

[a]. Time to Produce Effect: less than 30 minutes for local anesthesia; corticosteroids up to 72 hours for most patients.

[b]. Frequency and Maximum Duration: once per suspected level. Limited to two levels

(iii). Zygapophyseal (Facet) Blocks. Facet blocks are generally accepted but should not be considered diagnostic blocks for the purposes of determining the need for a rhizotomy (radiofrequency medial branch neurotomy), nor should they be done with medial branch blocks. These blocks should not be considered a definitive diagnostic tool. They may be used diagnostically to direct functional rehabilitation programs. A positive diagnostic block should result in a positive diagnostic functional benefit and a 50 percent reduction in pain appropriate for the anesthetic used as measured by accepted pain scales (such as a VAS). They then may be repeated per the therapeutic guidelines when they are accompanied by a functional rehabilitation program. (Refer to Therapeutic Spinal Injections).

[a]. Time to Produce Effect: Less than 30 minutes for local anesthesia; corticosteroids up to 72 hours for most patients;

[b]. Frequency and Maximum Duration: Once per suspected level, limited to two levels.

(iv). Sacroiliac Joint Injection. A generally accepted injection of local anesthetic in an intra-articular fashion into the sacroiliac joint under fluoroscopic guidance. Long-term therapeutic effect has not yet been established. Indications: Primarily diagnostic to rule out sacroiliac joint dysfunction versus other pain generators. Intra-articular injection can be of value in diagnosing the pain generator. There should be documented relief from previously painful maneuvers (e.g., Patrick’s test) and at least 50 percent pain relief on post-injection physical exam (as measured by accepted pain scales such as a VAS) correlated with functional improvement. Sacroiliac joint blocks should facilitate functionally directed rehabilitation programs.

[a]. Time to Produce Effect: Up to 30 minutes for local anesthetic;

[b]. Frequency and Maximum Duration: 1.

c. Personality/ Psychological/ Psychiatric/ Psychosocial Evaluation. These are generally accepted and well-established diagnostic procedures with selective use in the low back population, but have more widespread use in subacute and chronic low back populations. Diagnostic testing procedures may be useful for patients with symptoms of depression, delayed recovery, chronic pain, recurrent painful conditions, disability problems, and for preoperative evaluation. Psychological/psychiatric /psychosocial and measures have been shown to have predictive value for postoperative response, and therefore should be strongly considered for use pre-operatively when the surgeon has concerns about the relationship between symptoms and findings, or when the surgeon is aware of indications of psychological complication or risk factors for psychological complication (e.g. childhood psychological trauma). Psychological testing should provide differentiation between pre-existing conditions versus injury caused psychological conditions, including depression and posttraumatic stress disorder. Psychological testing should incorporate measures that have been shown, empirically, to identify comorbidities or risk factors that are linked to poor outcome or delayed recovery.

i. Formal psychological or psychosocial evaluation should be performed on patients not making expected progress within 6 to 12 weeks following injury and whose subjective symptoms do not correlate with objective signs and test results. In addition to the customary initial exam, the evaluation of the injured worker should specifically address the following areas:

- (a). employment history;
- (b). interpersonal relationships-both social and work;
- (c). patient activities;
- (d). current perception of the medical system;
- (e). current perception/attitudes toward employer/job;
- (f). results of current treatment;

(g). risk factors and psychological comorbidities that may influence outcome and that may require treatment;

(h). childhood history, including history of childhood psychological trauma, abuse and family history of disability.

ii. Personality/ psychological/ psychiatric / psychosocial evaluations consist of two components, clinical interview and psychological testing. Results should help clinicians with a better understanding of the patient in a number of ways. Thus, the evaluation result will determine the need for further psychosocial interventions; and in those cases, Diagnostic and Statistical Manual of Mental Disorders (DSM) diagnosis should be determined and documented. The evaluation should also include examination of both psychological comorbidities and psychological risk factors that are empirically associated with poor outcome and/or delayed recovery. An individual with a Ph.D., Psy.D, or psychiatric M.D./D.O. credentials should perform initial evaluations, which are generally completed within one to two hours. A professional fluent in the primary language of the patient is preferred. When such a provider is not available, services of a professional language interpreter should be provided.

(a). Frequency: one-time visit for the clinical interview. If psychometric testing is indicated as a part of the initial evaluation, time for such testing should not exceed an additional nine hours of professional time.

(b). Clinical Evaluation. At the discretion of the evaluating physician, clinical evaluation may address the following areas:

(i). History of Injury. The history of the injury should be reported in the patient’s words or using similar terminology. Caution must be exercised when using translators.

- [a]. nature of injury;
- [b]. psychosocial circumstances of the injury;
- [c]. current symptomatic complaints;
- [d]. extent of medical corroboration;
- [e]. treatment received and results;
- [f]. compliance with treatment;
- [g]. coping strategies used, including perceived locus of control;
- [h]. perception of medical system and employer;
- [i]. history of response to prescription medications.

(ii). Health History

- [a]. nature of injury;
- [b]. medical history;
- [c]. psychiatric history;

- [d]. history of alcohol or substance abuse;
- [e]. activities of daily living;
- [f]. mental status exam;
- [g]. previous injuries, including disability, impairment, and compensation

(iii). Psychosocial History

- [a]. childhood history, including abuse;
- [b]. educational history;
- [c]. family history, including disability;
- [d]. marital history and other significant adulthood activities and events;
- [e]. legal history, including criminal and civil litigation;
- [f]. employment and military history;
- [g]. signs of pre-injury psychological dysfunction;
- [h]. current interpersonal relations, support, living situation;
- [i]. financial history.

(iv). Psychological test results, if performed.

(v). Danger to self or others.

(vi). Current psychiatric diagnosis consistent with the standards of the American Psychiatric Association’s Diagnostic and Statistical Manual of Mental Disorders.

(vii). Pre-existing psychiatric conditions. Treatment of these conditions is appropriate when the pre-existing condition affects recovery from pain.

(viii). Causality (to address medically probable cause and effect, distinguishing pre-existing psychological symptoms, traits and vulnerabilities from current symptoms).

(ix). Treatment recommendations with respect to specific goals, frequency, timeframes, and expected outcomes.

(c). Tests of Psychological Functioning. Psychometric testing is a valuable component of a consultation to assist the physician in making a more effective treatment plan. Psychometric testing is useful in the assessment of mental conditions, pain conditions, cognitive functioning, treatment planning, vocational planning, and evaluation of treatment effectiveness. There is no general agreement as to which standardized psychometric tests should be specifically recommended for psychological evaluations of pain conditions. It is appropriate for the mental health provider to use their discretion and administer selective psychometric tests within their expertise and within standards of care in the community. Some of these tests are available in Spanish and other languages, and many are written at a sixth grade reading level. Examples of

frequently used psychometric tests performed include, but not limited to, the following.

(i). Comprehensive Inventories for Medical Patients

[a]. Battery for Health Improvement, 2nd Edition (BHI-2). What it measures: depression, anxiety and hostility; violent and suicidal ideation; borderline, dependency, maladjustment, substance abuse, conflicts with work, family and physician, pain preoccupation, somatization, perception of functioning and others. Benefits: when used as a part of a comprehensive evaluation, can contribute substantially to the understanding of psychosocial factors underlying pain reports, perceived disability, somatic preoccupation, and help to design interventions. Serial administrations can track changes in a broad range of variables during the course of treatment, and assess outcome.

[b]. Millon Behavioral Medical Diagnostic (MBMD). What it measures - updated version of the Millon Behavioral Health Inventory (MBHI). Provides information on coping styles (introversive, inhibited, dejected, cooperative, sociable, etc), health habits (smoking, drinking, eating, etc.), psychiatric indications (anxiety, depression, etc), stress moderators (illness apprehension vs. illness tolerance, etc), treatment prognostics (interventional fragility vs. interventional resilience, medication abuse vs. medication competence, etc) and other factors. Benefits: when used as a part of a comprehensive evaluation, can contribute substantially to the understanding of psychosocial factors affecting medical patients. Understanding risk factors and patient personality type can help to optimize treatment protocols for a particular patient.

[c]. Pain Assessment Battery (PAB). What it measures: collection of four separate measures that are administered together. Emphasis on the assessment of pain, coping strategies, degree and frequency of distress, health-related behaviors, coping success, beliefs about pain, quality of pain experience, stress symptoms analysis, and others. Benefits: when used as a part of a comprehensive evaluation, can contribute substantially to the understanding of patient stress, pain reports and pain coping strategies, and help to design interventions. Serial administrations can track changes in measured variables during the course of treatment, and assess outcome.

(d). Comprehensive Psychological Inventories. These tests are designed for detecting various psychiatric syndromes, but in general are more prone to false positive findings when administered to medical patients.

(i). Millon Clinical Multi-axial Inventory, 3rd Edition (MCMI-III). What it measures: has scales based on DSM diagnostic criteria for affective, personality, and psychotic disorders and somatization. Benefits: when used as a part of a part of a comprehensive evaluation, can screen for a broad range of DSM diagnoses.

(ii). Minnesota Multiphasic Personality Inventory, 2nd Edition (MMPI-2). What it measures:

original scale constructs, such as hysteria and psychesthesia are archaic but continue to be useful. Newer content scales include depression, anxiety, health concerns, bizarre mentation, social discomfort, low self-esteem, and almost 100 others. Benefits: when used as a part of a comprehensive evaluation, measure a number of factors that have been associated with poor treatment outcome.

(iii). Personality Assessment Inventory (PAI). What it measures: a good measure of general psychopathology. Measures depression, anxiety, somatic complaints, stress, alcohol and drug use reports, mania, paranoia, schizophrenia, borderline, antisocial, and suicidal ideation and more than 30 others. Benefits: when used as a part of a comprehensive evaluation, can contribute substantially to the identification of a wide variety of risk factors that could potentially affect the medical patient.

(e). Brief Multidimensional Screens for Medical Patients. Treating providers, to assess a variety of psychological and medical conditions, including depression, pain, disability and others, may use brief instruments. These instruments may also be employed as repeated measures to track progress in treatment, or as one test in a more comprehensive evaluation. Brief instruments are valuable in that the test may be administered in the office setting and hand scored by the physician. Results of these tests should help providers distinguish which patients should be referred for a specific type of comprehensive evaluation.

(i). Brief Battery for Health Improvement, 2nd Edition (BBHI-2). What it measures: depression, anxiety, somatization, pain, function, and defensiveness. Benefits: can identify patients needing treatment for depression and anxiety, and identify patients prone to somatization, pain magnification and self-perception of disability. Can compare the level of factors above to other pain patients and community members. Serial administrations can track changes in measured variables during the course of treatment, and assess outcome.

(ii). Multidimensional Pain Inventory (MPI). What it measures: interference, support, pain severity, life-control, affective distress, response of significant other to pain, and self-perception of disability at home and work, and in social and other activities of daily living. Benefits: can identify patients with high levels of disability perceptions, affective distress, or those prone to pain magnification. Serial administrations can track changes in measured variables during the course of treatment, and assess outcome.

(iii). Pain Patient Profile (P3). What it measures: Assesses depression, anxiety, and somatization. Benefits: Can identify patients needing treatment for depression and anxiety, as well as identify patients prone to somatization. Can compare the level of depression, anxiety and somatization to other pain patients and community members. Serial administrations can track changes in measured variables during the course of treatment, and assess outcome.

(iv). SF-36. What it measures: a survey of general health well-being and functional states. Benefits: assesses a broad spectrum of patient disability reports. Serial administrations could be used to track patient perceived functional changes during the course of treatment, and assess outcome.

(v). Sickness Impact Profile (SIP). What it measures: perceived disability in the areas of sleep, eating, home management, recreation, mobility, body care, social interaction, emotional behavior, and communication. Benefits: assesses a broad spectrum of patient disability reports. Serial administrations could be used to track patient perceived functional changes during the course of treatment, and assess outcome.

(vi). McGill Pain Questionnaire (MPQ). What it measures: cognitive, emotional and sensory aspects of pain. Benefits: can identify patients prone to pain magnification. Repeated administrations can track progress in treatment for pain.

(vii). McGill Pain Questionnaire-Short Form (MPQ-SF). What it measures: emotional and sensory aspects of pain. Benefits: can identify patients prone to pain magnification. Repeated administrations can track progress in treatment for pain.

(viii). Oswestry Disability Questionnaire. What it measures: disability secondary to low back pain. Benefits: can measure patients' self-perceptions of disability. Serial administrations could be used to track changes in self-perceptions of functional ability during the course of treatment, and assess outcome.

(ix). Visual Analog Scales (VAS). What it measures: graphical measure of patient's pain report. Benefits: quantifies the patients' pain report. Serial administrations could be used to track changes in pain reports during the course of treatment and assess outcome.

(f). Brief Multidimensional Screens for Psychiatric Patients. These tests are designed for detecting various psychiatric syndromes, but in general are more prone to false positive findings when administered to medical patients.

(i). Brief Symptom Inventory. What it measures: Somatization, obsessive-compulsive, depression, anxiety, phobic anxiety, hostility, paranoia, psychoticism, and interpersonal sensitivity. Benefits: can identify patients needing treatment for depression and anxiety, as well as identify patients prone to somatization. Can compare the level of depression, anxiety, and somatization to community members. Serial administrations could be used to track changes in measured variables during the course of treatment, and assess outcome.

(ii). Brief Symptom Inventory-18 (BSI-18). What it Measures: depression, anxiety, somatization. Benefits: can identify patients needing treatment for depression and anxiety, as well as identify patients prone to somatization. Can compare the level of depression, anxiety, and somatization to community members. Serial

administrations could be used to track patient perceived functional changes during the course of treatment, and assess outcome.

(iii). Symptom Check List 90 (SCL 90). What it measures: Somatization, obsessive-compulsive, depression, anxiety, phobic anxiety, hostility, paranoia, psychoticism, and interpersonal sensitivity. Benefits: Can identify patients needing treatment for depression and anxiety, as well as identify patients prone to somatization. Can compare the level of depression, anxiety and somatization to community members. Serial administrations could be used to track changes in measured variables during the course of treatment, and assess outcome.

(g). Brief Specialized Psychiatric Screening Measures

(i). Beck Depression Inventory (BDI). What it measures: Depression. Benefits: Can identify patients needing referral for further assessment and treatment for depression and anxiety, as well as identify patients prone to somatization. Repeated administrations can track progress in treatment for depression, anxiety, and somatic preoccupation.

(ii). Post Traumatic Stress Diagnostic Scale (PDS). What it Measures: Post Traumatic Stress Disorder (PTSD). Benefits: Helps confirm suspected PTSD diagnosis. Repeated administrations can track treatment progress of PTSD patients.

(iii). Center of Epidemiologic Studies-Depression Questionnaire. What it measures: Depression. Benefits: Brief self-administered screening test. Requires professional evaluation to verify diagnosis.

(iv). Brief Patient Health Questionnaire from PRIME - MD. What it measures: Depression, panic disorder. Benefits: Brief self-administered screening test. Requires professional evaluation to verify diagnosis.

(v). Zung Questionnaire. What it measures: Depression. Benefits: Brief self-administered screening test. Requires professional evaluation to verify diagnosis.

(vi). Diagnostic Studies. Imaging of the spine and/or extremities is a generally accepted, well-established, and widely used diagnostic procedure when specific indications, based on history and physical examination, are present. Physicians should refer to individual OWCA guidelines for specific information about specific testing procedures.

(vii). Radiographic Imaging, MRI, CT, bone scan, radiography, SPECT and other special imaging studies may provide useful information for many musculoskeletal disorders causing pain. Single Photon Emission Computerized Tomography (SPECT). A scanning technique which may be helpful to localize facet joint pathology and is useful in determining which patients are likely to have a response to facet injection. SPECT combines bone scans and CT Scans in looking for facet joint pathology.

(viii). Electrodiagnostic studies may be useful in the evaluation of patients with suspected myopathic or neuropathic disease and may include Nerve Conduction Studies (NCS), Standard Needle Electromyography, or Somatosensory Evoked Potential (SSEP). The evaluation of electrical studies is difficult and should be relegated to specialists who are well trained in the use of this diagnostic procedure.

(ix). Special Testing Procedures may be considered when attempting to confirm the current diagnosis or reveal alternative diagnosis. In doing so, other special tests may be performed at the discretion of the physician.

(x). Testing for complex regional pain syndrome (CRPS-I) or sympathetically maintained pain (SMP) is described in the Complex Regional Pain Syndrome/Reflex Sympathetic Dystrophy Medical Treatment Guidelines.

#### d. Provocation Discography

i. Description. Discography is an accepted, but rarely indicated, invasive diagnostic procedure to identify or refute a discogenic source of pain for patients who are surgical candidates. Discography should only be performed by physicians who are experienced and have been proctored in the technique. Discograms have a significant false positive rate. It is essential that all indications, pre-conditions, special considerations, procedures, reporting requirements, and results are carefully and specifically followed. Results should be interpreted judiciously.

ii. Indications. Discography may be indicated when a patient has a history of functionally limiting, unremitting low back pain of greater than four months duration, with or without leg pain, which has been unresponsive to all conservative interventions. A patient who does not desire operative therapeutic intervention is not a candidate for an invasive non-therapeutic intervention, such as provocation discography.

(a). Discography may prove useful for the evaluation of the pre-surgical spine, such as pseudarthrosis, discogenic pain at levels above or below a prior spinal fusion, annular tear, or internal disc disruption.

(b). Discography may show disc degeneration and annular disruption in the absence of low back pain. Discography may also elicit concordant pain in patients with mild and functionally inconsequential back pain. Because patients with mild back pain should not be considered for invasive treatment, discography should not be performed on these patients. In symptomatic patients with annular tears on discography, the side of the tear does not necessarily correlate with the side on which the symptoms occur. The presence of an annular tear does not necessarily identify the tear as the pain generator.

(c). Discography is not useful in previously operated discs, but may have a limited place in the work-up of pseudarthrosis. Discography may prove useful in evaluating the number of lumbar spine levels that might require fusion. CT-Discography provides further detailed

information about morphological abnormalities of the disc and possible lateral disc herniations.

iii. Pre-conditions for provocation discography include all of the following.

(a). A patient with functionally limiting, unremitting back and/or leg pain of greater than four months duration in whom conservative treatment has been unsuccessful and in whom the specific diagnosis of the pain generator has not been made apparent on the basis of other noninvasive imaging studies (e.g., MRI, CT, plain films, etc.). It is recommended that discography be reserved for use in patients with equivocal MRI findings, especially at levels adjacent to clearly pathological levels. Discography may be more sensitive than MRI or CT in detecting radial annular tears. However, radial tears must always be correlated with clinical presentation.

(b). Psychosocial Evaluation has been completed. There is some evidence that false positives and complaints of long-term pain arising from the procedure itself occur more frequently in patients with somatoform disorders. Therefore, discograms should not be performed on patients with somatoform disorders.

(c). Patients who are considered surgical candidates (e.g., symptoms are of sufficient magnitude and the patient has been informed of the possible surgical options that may be available based upon the results of discography). Discography should never be the sole indication for surgery.

(d). Informed consent regarding the risks and potential diagnostic benefits of discography has been obtained.

iv. Complications-include, but are not limited to, discitis, nerve damage, chemical meningitis, pain exacerbation, and anaphylaxis therefore, prior to consideration of discography, the patient should undergo other diagnostic modalities in an effort to define the etiology of the patient's complaint including psychological evaluation, myelography, CT and MRI.

#### v. Contraindications-include:

(a). active infection of any type or continuing antibiotic treatment for infection; and/or

(b). bleeding diathesis or pharmaceutical anticoagulation with warfarin, etc.; and/or

(c). significant spinal stenosis at the level being studied as visualized by MRI, myelography or CT scan; and/or

(d). presence of clinical myelopathy; and/or

(e). effacement of the cord, thecal sac or circumferential absence of epidural fat; and

(f). known allergic reactions.

#### vi. Special Considerations

## LABOR AND EMPLOYMENT

(a). Discography should not be performed by the physician expected to perform the therapeutic procedure. The procedure should be carried out by an experienced individual who has received specialized training in the technique of provocation discography.

(b). Discography should be performed in a blinded format that avoids leading the patient with anticipated responses. The procedure should always include one or more disc levels thought to be normal or non-painful in order to serve as an internal control. The patient should not know what level is being injected in order to avoid spurious results. Abnormal disc levels may be repeated to confirm concordance.

(c). Sterile technique must be utilized.

(d). Judicious use of light sedation during the procedure is acceptable, represents the most common practice nationally at the current time, and is recommended by most experts in the field. The patient must be awake and able to accurately report pain levels during the provocation portion of the procedure.

(e). The discography should be performed using a manometer to record pressure. Pressure should not exceed 50 pounds per square inch (psi) above opening pressure.

(f). Intradiscal injection of local anesthetic may be carried out after the provocation portion of the examination and the patient's response.

(g). It is recommended that a post-discogram CT be considered as it frequently provides additional useful information about disc morphology or other pathology.

vii. Reporting of Discography. In addition to a narrative report, the discography report should contain a standardized classification of disc morphology the pain response, and the pressure at which pain is produced. All results should be clearly separated in the report from the narrative portion. Asymptomatic annular tears are common and the concordant pain response is an essential finding for a positive discogram.

(a). When discography is performed to identify the source of a patient's low-back pain, both a concordant pain response and morphological abnormalities must be present at the pathological level prior to initiating any treatment directed at that level. The patient must be awake during the provocation phase of the procedure; therefore, sedative medication must be carefully titrated.

(b). Caution should be used when interpreting results from discography. Several studies indicate that a false positive discogram for pain is likely above a pressure reading of 50 psi above opening pressure. The false positive rate appears to drop to approximately 25 percent using a pressure of 20 psi above opening pressure in a population with low back pain.

(i). Reporting disc morphology as visualized by the post-injection CT scan (when available) should follow the Modified Dallas Discogram Scale where:

[a]. Grade 0 = Normal Nucleus

[b]. Grade 1 = Annular tear confined to inner one-third of annulus fibrosis.

[c]. Grade 2 = Annular tear extending to the middle third of the annulus fibrosis.

[d]. Grade 3 = Annular tear extending to the outer one-third of the annulus fibrosis.

[e]. Grade 4 = A grade 3 tear plus dissection within the outer annulus to involve more than 30 degrees of the disc circumference.

[f]. Grade 5 = Full thickness tear with extra-annular leakage of contrast, either focal or diffuse.

(ii). Reporting of pain response should be consistent with the operational criteria of the International Spine Intervention Society (ISIS) Guidelines or American Society of Interventional Pain Physicians (ASIPP) Guidelines. The report must include the level of concordance for back pain and /or leg pain using a 10-point VAS, or similar quantitative assessment. It should be noted that change in the VAS scale before and after provocation is more important than the number reported.

[a]. Unequivocal Discogenic Pain

[i]. stimulation of the target disc reproduces concordant pain

[ii]. the pain should be registered at least 7 on a 10-point VAS.

[iii].the pain is reproduced at a pressure of less than 15 psi above opening pressure; and

[iv].stimulation of two adjacent discs does not produce pain at all

[b]. Definite Discogenic Pain

[i]. stimulation of the target disc reproduces concordant pain

[ii]. the pain should be registered as at least 7 on a 10-point VAS.

[iii].the pain is reproduced at a pressure of less than 15 psi above opening pressure; and

[iv].stimulation of at least one adjacent disc does not produce pain at all

[c]. Highly Probable Discogenic Pain

[i]. stimulation of the target disc reproduces concordant pain

[ii]. that pain should be registered as at least 7 on a 10-point VAS.

[iii].that the pain is reproduced at a pressure of less than 50 psi above opening pressure; and,

[iv].stimulation of two adjacent discs does not produce pain at all

[d]. Probable Discogenic Pain

[i]. stimulation of the target disc reproduces concordant pain;

[ii]. that pain should be registered as at least 7 on a 10-point VAS;

[iii].the pain is reproduced at a pressure of less than 50 psi above opening pressure; and

[iv].stimulation of one adjacent disc does not produce pain at all, and stimulation of another adjacent disc at greater than 50 psi, produces pain, but the pain is not concordant.

[e]. Multiple combinations of factors are possible. However, if the patient does not qualify for at least a 'Probable Discogenic Pain' level, then the discogram should be considered negative. The VAS score prior to the discogram should be taken into account when interpreting the VAS score reported by the patient during the discogram.

[i]. Time Parameters for Provocation Discography are as follows:

aa. Frequency: One time only

bb.Maximum: Repeat Discography

is rarely indicated

3. Special tests are generally well-accepted tests and are performed as part of a skilled assessment of the patients' capacity to return to work, his/her strength capacities, and physical work demand classifications and tolerance. The procedures in this subsection are listed in alphabetical order, not by importance.

a. Computer-Enhanced Evaluations: may include isotonic, isometric, isokinetic and/or isoinertial measurement of movement, range of motion, endurance, or strength. Values obtained can include degrees of motion, torque forces, pressures, or resistance. Indications include determining validity of effort, effectiveness of treatment and demonstrated motivation. These evaluations should not be used alone to determine return to work restrictions.

i. Frequency—one time for evaluation. Can monitor improvements in strength every three to four weeks up to a total of six evaluations.

b. Functional capacity evaluation (FCE) is a comprehensive or modified evaluation of the various aspects of function as they relate to the worker's ability to return to work. FCEs should not be used as the sole criteria to diagnose malingering. Areas such as endurance, lifting (dynamic and static), postural tolerance, specific range of motion (ROM), coordination and strength, worker habits, employability as well as psychosocial, cognitive, and sensory perceptual aspects of competitive employment may be evaluated. Reliability of patient reports and overall effort during testing is also reported. Components of this

evaluation may include: musculoskeletal screen; cardiovascular profile/aerobic capacity; coordination; lift/carrying analysis; job-specific activity tolerance; maximum voluntary effort; pain assessment/psychological screening; and non-material and material handling activities. Standardized national guidelines (such as National Institute for Occupational Safety and Health (NIOSH)) should be used as the basis for FCE recommendations.

i. When an FCE is being used to determine return to a specific jobsite, the provider is responsible for fully understanding the physical demands and the duties of the job that the worker is attempting to perform. A jobsite evaluation is frequently necessary. A job description should be reviewed by the provider and FCE evaluator prior to this evaluation. FCEs cannot be used in isolation to determine work restrictions. It is expected that the FCE may differ from both self-report of abilities and pure clinical exam findings. The length of a return to work evaluation should be based on the judgment of the referring physician and the provider performing the evaluation. Since return to work is a complicated multidimensional issue, multiple factors beyond functional ability and work demands should be considered and measured when attempting determination of readiness or fitness to return to work. The authorized treating physician must interpret the FCE in light of the individual patient's presentation and medical and personal perceptions. FCEs should not be used as the sole criteria to diagnose malingering.

ii. Depth and breadth of FCE should be assessed on a case-by-case basis and should be determined by tester and/or referring medical professional. In many cases, a work tolerance screening or return to work performance will identify the ability to perform the necessary job tasks. There is some evidence that a short form FCE reduced to a few tests produces a similar predictive quality compared to the longer two-day version of the FCE regarding length of disability and recurrence of a claim after return to work.

(a). Frequency. When the patient is unable to return to the pre-injury condition and further information is desired to determine permanent work restrictions. Prior authorization is required for repeat FCEs.

c. Jobsite Evaluation—a comprehensive analysis of the physical, mental, and sensory components of a specific job. The goal of the Jobsite evaluation is to identify any job modification needed to ensure the safety of the employee upon return to work. These components may include, but are not limited to: postural tolerance (static and dynamic); aerobic requirements; range of motion (ROM); torque/force; lifting/carrying; cognitive demands; social interactions; visual perceptual; sensation; coordination; environmental requirements of a job; repetitiveness; essential job functions; and ergonomic set up. Job descriptions provided by the employer are helpful but should not be used as a substitute for direct observation.

i. A jobsite evaluation may include observation and instruction of how work is done, what material changes

(desk, chair) should be made, and determination of readiness to return to work.

ii. Requests for a jobsite evaluation should describe the expected goals for the evaluation. Goals may include, but are not limited to the following:

(a). to determine if there are potential contributing factors to the person’s condition and/or for the physician to assess causality;

(b). to make recommendations for, and to assess the potential for ergonomic changes;

(c). to provide a detailed description of the physical and cognitive job requirements;

(d). to assist the patient in their return to work by educating them on how they may be able to do their job more safely in a bio-mechanically appropriate manner;

(e). to give detailed work/activity restrictions.

(i). Frequency—one time with additional visits as needed for follow-up per jobsite.

iii. Jobsite evaluation and alteration should include input from a health care professional with experience in ergonomics or a certified ergonomist, the employee, and the employer. The employee must be observed performing all job functions in order for the jobsite evaluation to be a valid representation of a typical workday. If the employee is unable to perform the job function for observation, a co-worker in an identical job position may be observed instead. Periodic follow-up is recommended to assess the effectiveness of the intervention and need for additional ergonomic changes.

d. Vocational Assessment. The vocational assessment should provide valuable guidance in the determination of future rehabilitation program goals. It should clarify rehabilitation goals, which optimize both patient motivation and utilization of rehabilitation resources. If prognosis for return to former occupation is determined to be poor, except in the most extenuating circumstances, vocational assessment should be implemented within 3 to 12 months post-injury. Declaration of Maximum Medical Improvement (MMI) should not be delayed solely due to lack of attainment of a vocational assessment.

i. Frequency—one time with additional visits as needed for follow-up

e. Work Tolerance Screening (Fitness for Duty) - a determination of an individual's tolerance for performing a specific job as based on a job activity or task and may be used when a full Functional Capacity Evaluation is not indicated. It may include a test or procedure to specifically identify and quantify work-relevant cardiovascular, physical fitness and postural tolerance. It may also address ergonomic issues affecting the patient’s return-to-work potential.

i. Frequency—one time for initial screen. May monitor improvements in strength every three to four weeks up to a total of six visits.

AUTHORITY NOTE: Promulgated in accordance with R.S. 23:1203.1.

HISTORICAL NOTE: Promulgated by the Louisiana Workforce Commission, Office of Workers Compensation Administration, LR 37:1658 (June 2011), amended by the Louisiana Workforce Commission, Office of Workers Compensation, LR 40:1137 (June 2014), LR 46:1246 (September 2020), LR 49:519 (March 2023).

**§2021. Therapeutic Procedures—Non-Operative**

A. All treatment plans begin with shared decision making with the patient. Before initiation of any therapeutic procedure, an authorized treating healthcare provider, employer, and insurer should consider these important issues in the care of the injured worker.

B. First, patients undergoing therapeutic procedure(s) should be released or returned to modified or restricted duty during their rehabilitation at the earliest appropriate time. Refer to “Return-to-Work” in this section for detailed information.

C. Second, cessation and/or review of treatment modalities should be undertaken when no further significant subjective or objective improvement in the patient’s condition is noted.

1. Reassessment of the patient’s status in terms of functional improvement should be documented after each treatment. If patients are not responding within the recommended time periods, alternative treatment interventions, further diagnostic studies or specialist and/or surgeon consultations should be pursued. Continued treatment should be monitored using objective measures such as:

a. return-to-work or maintaining work status;

b. fewer restrictions at work or performing activities of daily living (ADL);

c. decrease in usage of medications; related to the work injury; and

d. measurable functional gains, such as increased range of motion, documented increase in strength, increased ability to stand, sit or lift, or patient completed functional evaluations.

D. Third, providers should provide and document education to the patient. No treatment plan is complete without addressing issues of individual and/or group patient education as a means of facilitating self-management of symptoms.

E. Lastly, formal psychological or psychosocial evaluation should be performed on patients not making expected progress within 6 to 12 weeks following injury and whose subjective symptoms do not correlate with objective signs and tests.

F. Home therapy is an important component of therapy and may include active and passive therapeutic procedures, as well as, other modalities to assist in alleviating pain, swelling, and abnormal muscle tone.



G. Non-operative treatment procedures for low back pain can be divided into two groups: conservative care and rehabilitation. Conservative care is treatment applied to a problem in which spontaneous improvement is expected in 90 percent of the cases within three months. It is usually provided during the tissue-healing phase and lasts no more than six months, and often considerably less. Rehabilitation is treatment applied to a more chronic and complex problem in a patient with de-conditioning and disability. It is provided during the period after tissue healing to obtain maximal medical recovery. Treatment modalities may be utilized sequentially or concomitantly depending on chronicity and complexity of the problem, and anticipated therapeutic effect. Treatment plans should always be based on a diagnosis utilizing appropriate diagnostic procedures.

H. The following procedures are listed in alphabetical order.

#### 1. Acupuncture

a. Acupuncture: the insertion and removal of filiform needles to stimulate acupoints (acupuncture points). Needles may be inserted, manipulated, and retained for a period of time. Acupuncture can be used to reduce pain, reduce inflammation, increase blood flow, increase range of motion, decrease the side effect of medication-induced nausea, promote relaxation in an anxious patient, and reduce muscle spasm.

i. Indications include joint pain, joint stiffness, soft tissue pain and inflammation, paresthesia, post-surgical pain relief, muscle spasm, and scar tissue pain.

b. Acupuncture with Electrical Stimulation: is the use of electrical current (micro-amperage or milli-amperage) on the needles at the acupuncture site. It is used to increase effectiveness of the needles by continuous stimulation of the acupoint. Physiological effects (depending on location and settings) can include endorphin release for pain relief, reduction of inflammation, increased blood circulation, analgesia through interruption of pain stimulus, and muscle relaxation.

i. It is indicated to treat chronic pain conditions, radiating pain along a nerve pathway, muscle spasm, inflammation, scar tissue pain, and pain located in multiple sites.

c. Total Time Frames for Acupuncture and Acupuncture with Electrical Stimulation: Time frames are not meant to be applied to each of the above sections separately. The time frames are to be applied to all acupuncture treatments regardless of the type or combination of therapies being provided.

- i. time to produce effect: three to six treatments;
- ii. frequency: one to three times per week;
- iii. optimum duration: one to two months;
- iv. maximum duration: 14 treatments within six months.

(a). Any of the above acupuncture treatments may extend longer if objective functional gains can be documented or when symptomatic benefits facilitate progression in the patient's treatment program. Treatment beyond 14 treatments must be documented with respect to need and ability to facilitate positive symptomatic or functional gains. Such care should be re-evaluated and documented with each series of treatments.

2. Biofeedback. A form of behavioral medicine that helps patients learn self-awareness and self-regulation skills for the purpose of gaining greater control of their physiology, such as muscle activity, brain waves, and measures of autonomic nervous system activity. Electronic instrumentation is used to monitor the targeted physiology and then displayed or fed back to the patient visually, auditorially, or tactilely, with coaching by a biofeedback specialist. Biofeedback is provided by clinicians certified in biofeedback and/or who have documented specialized education, advanced training, or direct or supervised experience qualifying them to provide the specialized treatment needed (e.g., surface EMG, EEG, or other). There is good evidence that biofeedback or relaxation therapy is equal in effect to cognitive behavioral therapy for low back pain. There is good evidence that cognitive behavioral therapy, but not behavioral therapy (e.g., biofeedback), shows weak to small effects in reducing pain and small effects on improving disability, mood, and catastrophizing in patients.

a. Treatment is individualized to the patient's work-related diagnosis and needs. Home practice of skills is required for mastery and may be facilitated by the use of home training tapes. The ultimate goal of biofeedback treatment is to normalize physiology to the pre-injury status to the extent possible, and involves transfer of learned skills to the workplace and daily life. Candidates for biofeedback therapy or training must be motivated to learn and practice biofeedback and self-regulation techniques.

b. Indications for biofeedback include individuals who are suffering from musculoskeletal injury in which muscle dysfunction or other physiological indicators of excessive or prolonged stress response affects and/or delays recovery. Other applications include training to improve self-management of emotional stress/pain responses such as anxiety, depression, anger, sleep disturbance, and other central and autonomic nervous system imbalances. Biofeedback is often used in conjunction with other treatment modalities.

- i. time to produce effect: three to four sessions;
  - ii. frequency: one to two times per week;
  - iii. optimum duration: five to six sessions;
  - iv. maximum duration: 10 to 12 sessions.
- Treatment beyond 12 sessions must be documented with respect to need, expectation, and ability to facilitate functional gains.

#### 3. Injections—Therapeutic

a. Therapeutic Spinal Injections.

Description—Therapeutic spinal injections may be used after initial conservative treatments, such as physical and occupational therapy, medication, manual therapy, exercise, acupuncture, etc., have been undertaken. Therapeutic injections should be used only after imaging studies and diagnostic injections have established pathology. Injections are invasive procedures that can cause serious complications; thus clinical indications and contraindications should be closely adhered to. The purpose of spinal injections is to facilitate active therapy by providing short-term relief through reduction of pain and inflammation. All patients should continue appropriate exercise with functionally directed rehabilitation. Active treatment, which patients should have had prior to injections, will frequently require a repeat of the sessions previously ordered (Refer to Active Therapy). Injections, by themselves, are not likely to provide long-term relief. Rather, active rehabilitation with modified work achieves long-term relief by increasing active ROM, strength, and stability. Subjective reports of pain response (via a recognized pain scale) and function should be considered and given relative weight when the pain has anatomic and physiologic correlation. Anatomic correlation must be based on objective findings.

i. Special Considerations. For all injections (excluding trigger point), multi-planar fluoroscopic guidance during procedures is required to document technique and needle placement, and should be performed by a physician experienced in the procedure. Permanent images are required to verify needle replacement.

ii. Complications. General complications of spinal injections may include transient neurapraxia, local pain, nerve injury, infection, headache, urinary retention, and vasovagal effects. Epidural hematoma, permanent neurologic damage, dural perforation and CSF leakage; and/or spinal meningeal abscess may also occur. Permanent paresis, anaphylaxis, and arachnoiditis have been rarely reported with the use of epidural steroids. With steroid injections, there may be a dose-dependent suppression of the hypothalamic-pituitary-adrenal axis lasting between one and three months.

iii. Contraindications. Absolute contraindications to therapeutic injections include: bacterial infection—systemic or localized to region of injection; bleeding diatheses; hematological conditions, and possible pregnancy.

(a). Relative contraindications to diagnostic injections may include: allergy to contrast, poorly controlled Diabetes Mellitus, and hypertension. Drugs affecting coagulation may require restriction from use. Anti-platelet therapy and anti-coagulations should be addressed individually by a knowledgeable specialist. It is recommended to refer to Am Society of Regional Anesthesia for anticoagulation guidelines.

b. Epidural Steroid Injection (ESI)

i. Description. Epidural steroid injections are injections of corticosteroid into the epidural space. The purpose of ESI is to reduce pain and inflammation in the

acute or sub-acute phases of injury, restoring range of motion and, thereby, facilitating progress in more active treatment programs. ESI uses three approaches: transforaminal/Spinal Selective Nerve Block (SNRB), interlaminar (midline), and caudal. The transforaminal/Spinal Selective Nerve Root Block approach is the preferred method for unilateral, single-level pathology and for post-surgical patients. There is good evidence that the transforaminal/Spinal Selective Nerve Root Block approach can deliver medication to the target tissue with few complications and can be used to identify the specific site of pathology. The interlaminar approach is the preferred approach for multi-level pathology or spinal stenosis. Caudal therapeutic injections may be used, but it is difficult to target the exact treatment area, due to diffuse distribution.

ii. Needle Placement. Multi-planar fluoroscopic imaging is required for all epidural steroid injections. Contrast epidurograms allow one to verify the flow of medication into the epidural space. Permanent images are required to verify needle replacement.

iii. Indications

(a). There is some evidence that epidural steroid injections are effective for patients with radicular pain or radiculopathy (sensory or motor loss in a specific dermatome or myotome). Up to 80 percent of patients with radicular pain may have initial relief. However, only 25-57 percent are likely to have excellent long-term relief.

(b). Although there is no evidence regarding the effectiveness of ESI for non-radicular disc herniation, it is an accepted intervention. Only patients who have pain affected by activity and annular tears verified by appropriate imaging may have injections for axial pain.

(c). There is some evidence that ESI injections are not effective for spinal stenosis without radicular findings. Additionally, there is some evidence that patients who smoke or who have pain unaffected by rest or activity are less likely to have a successful outcome from ESIs.

iv. Timing/Frequency/Duration

(a). Epidural injections may be used for radicular pain or radiculopathy. If an injection provides at least 50 percent relief, a repeat of the same pain relieving injection may be given at least two weeks apart with fluoroscopic guidance. No more than two levels may be injected in one session. If there is not a minimum of 50 percent pain reduction as measured by a numerical pain index scale and documented functional improvement, similar injections should not be repeated, although the practitioner may want to consider a different approach or different level depending on the pathology. Maximum of two series (six months apart) of three effective pain relieving injections may be done in one year based upon the patient's response to pain and function.

(b). Spinal Stenosis Patients

(i). Patients with claudication: The patient has documented spinal stenosis, has attempted active therapy,

has persistent claudication symptoms and difficulty with some activities, thus meeting criteria for surgical intervention. The patient may have diagnostic injection as indicated. Patients who have any objective neurologic findings should proceed as the above patient with radicular findings for whom an early surgical consultation is recommended including indirect or direct decompression. Refer to C.1. Those who have mild claudication, or moderate or severe claudication and who do not desire surgery, may continue to receive additional injections if the original diagnostic intervention was successful per guideline standards.

c. Zygapophyseal (Facet) Injection

i. Description—an accepted intra-articular or pericapsular injection of local anesthetic and corticosteroid with very limited uses. Up to three joints. Either unilaterally or bilaterally. Injections may be repeated only when there is 50 percent initial improvement in pain scales as measured by accepted pain scales (such as VAS), and a functional documented response lasts for three months. An example of a positive result would include a return to baseline function as established at MMI, return to increased work duties, or a measurable improvement in physical activity goals including return to baseline after an exacerbation. Injections may only be repeated when these functional and time goals are met and verified. May be repeated up to two times a year. There is no justification for a combined facet and medial branch block. Monitored Anesthesia Care is accepted for diagnostic and therapeutic procedures.

ii. Indications—patients with pain suspected to be facet in origin based on exam findings and affecting activity; or, patients who have refused a rhizotomy; or, patients who have facet findings with a thoracic component. In these patients, facet injections may be occasionally useful in facilitating a functionally-directed rehabilitation program and to aid in identifying pain generators. Patients with recurrent pain should be evaluated with more definitive diagnostic injections, such as medial nerve branch injections, to determine the need for a rhizotomy. Facet injections are not likely to produce long-term benefit by themselves and are not the most accurate diagnostic tool.

d. Sacroiliac Joint Injection

i. Description—a generally accepted injection of local anesthetic in an intra-articular fashion into the sacroiliac joint under fluoroscopic guidance. May include the use of corticosteroids. Sacroiliac joint injections may be considered either unilaterally or bilaterally. The injection may only be repeated with 50 percent improvement in Visual Analog Scale with documented functional improvement. For Sacroiliac Joint (lateral Branch Neurotomy), the diagnostic S1-S3 lateral branch blocks would need to be documented with 80 percent to 100 percent improvement in symptoms for the duration of the local anesthetic. Should the diagnostic lateral branch nerve blocks only result in 50 percent to 80 percent improvement in symptoms then the confirmatory nerve blocks are recommended. In the event that the diagnostic lateral nerve blocks result in less than 50 percent

improvement, then the lateral branch neurotomy is not recommended. SI Joint fusion can be considered if multiple SI joint injections or RF Sacral Lateral Branches are ineffective to maintain function. Monitored Anesthesia Care is accepted for diagnostic and therapeutic procedures.

ii. Indications—primarily diagnostic to rule out sacroiliac joint dysfunction vs. other pain generators. Intra-articular injection can be of value in diagnosing the pain generator. There should be documented relief from previously painful maneuvers (e.g., Patrick's test) on post-injection physical exam. These injections may be repeated if they result in increased documented functional benefit for at least 6 weeks and at least a 50 percent initial improvement in pain scales as measured by accepted pain scales (such as VAS). Sacroiliac joint blocks should facilitate a functionally directed rehabilitation program.

iii. Timing/Frequency/Duration

(a). Frequency and optimum duration: two to three injections per year. If the first injection does not provide a diagnostic response of temporary and sustained pain relief substantiated by accepted pain scales, (i.e., 50 percent pain reduction substantiated by tools such as VAS), and improvement in function, similar injections should not be repeated. At least six weeks of functional benefit should be obtained with each therapeutic injection. If there is a 50 percent reduction in pain that lasts less than six weeks, the injection can be considered as part of the series of two injections used for the purpose of confirming the sacroiliac pain generator prior to sacroiliac fusion.

(b). Maximum duration: three injections per year.

e. Intradiscal Steroid Therapy

i. Intradiscal Steroid Therapy consists of injection of a steroid preparation into the intervertebral disc under fluoroscopic guidance at the time of discography. There is good evidence that it is not effective in the treatment of suspected discogenic back pain and its use is not recommended.

f. Radio Frequency (RF)—Medial Branch Neurotomy/Facet Denervation

i. Description—a procedure designed to denervate the facet joint (Thoracic and Lumbar) by ablating the corresponding sensory medial branches. Percutaneous radiofrequency is the method generally used. Pulsed radiofrequency at 42 degrees C should not be used as it may result in incomplete denervation. Cooled radiofrequency is generally not recommended due to current lack of evidence.

(a). If the medial branch blocks provide 80 percent or more pain reduction as measured by a numerical pain index scale within one hour of the medial branch blocks, then rhizotomy of the medial branch nerves, up to four nerves per side, may be done. If the first medial branch block provides less than 80 percent but at least 50 percent pain reduction as measured by a numerical pain index scale or documented functional improvement, the medial branch block should be repeated before a rhizotomy is performed. If

50 percent or greater pain reduction is achieved with two sets of medial branch blocks for facet joint pain, then rhizotomy may be performed.

(b). Generally, RF pain relief lasts at least six months and repeat radiofrequency neurotomy can be successful and last longer. RF neurotomy is the procedure of choice over alcohol, phenol, or cryoablation. Permanent images should be recorded to verify placement of the needles.

ii. Needle placement: multi-planar fluoroscopic imaging is required for all injections.

iii. Indications—those patients with proven, significant, facetogenic pain by medial branch block (as defined previously). This procedure is not recommended for patients with multiple pain generators except in those cases where the facet pain is deemed to be greater than 50 percent of the total pain in the given area.

iv. All patients should continue appropriate exercise with functionally directed rehabilitation. Active treatment, which patients will have had prior to the procedure, will frequently require a repeat of the sessions that may have been previously ordered prior to the facet treatment (Refer to Therapy-Active).

v. Complications—bleeding, infection, or neural injury. The clinician must be aware of the risk of developing a localized neuritis, or rarely, a deafferentation centralized pain syndrome as a complication of this and other neuroablative procedures.

vi. Post-Procedure Therapy—active therapy. Implementation of a gentle aerobic reconditioning program (e.g., walking) and back education within the first post-procedure week, barring complications. Instruction and participation in a long-term home-based program of ROM, core strengthening, postural or neuromuscular re-education, endurance, and stability exercises should be accomplished over a period of four to ten visits post-procedure.

vii. Requirements for Repeat Radiofrequency Medial Branch Neurotomy (or other peripheral nerve ablation). In some cases pain may recur. Successful RF neurotomy usually provides from six to eighteen months of relief.

(a). Before a repeat RF neurotomy is done, a confirmatory medial branch injection or diagnostic nerve block should be performed if the patient's pain pattern presents differently than the initial evaluation. In occasional patients, additional levels of medial branch blocks and RF neurotomy may be necessary. The same indications and limitations apply.

g. Radio Frequency Denervation—Sacro-iliac (SI) joint. This procedure requires neurotomy of multiple nerves, such as L5 dorsal ramus, and/or lateral branches of S1-S3 under C-arm fluoroscopy.

i. Needle Placement: Multi-planar fluoroscopic imaging is required. Permanent images are suggested to verify needle placement.

## ii. Indications

(a). The patient has physical exam findings of at least three positive physical exam maneuvers (e.g., Patrick's sign, Faber's test, Gaenslen distraction or gapping, or compression test). Insufficient functional progress during an appropriate program that includes active therapy and/or manual therapy.

(b). For sacroiliac joint (lateral branch neurotomy), the diagnostic S1-S3 lateral branch blocks would need to be documented with 80 percent to 100 percent improvement in symptoms for the duration of the local anesthetic. Should the diagnostic lateral branch nerve blocks only result in 50 percent to 80 percent improvement in symptoms then the confirmatory nerve blocks are recommended. In the event that the diagnostic lateral nerve blocks result in less than 50 percent improvement, then the lateral branch neurotomy is not recommended. SI Joint fusion can be considered for those unable to return to function due to with SI injections or RF sacral lateral branches.

iii. Complications: damage to sacral nerve roots—issues with bladder dysfunction etc. Bleeding, infection, or neural injury. The clinician must be aware of the risk of developing a localized neuritis, or rarely, a deafferentation centralized pain syndrome as a complication of this and other neuroablative procedures.

iv. Post-Procedure Therapy—active therapy: implementation of a gentle aerobic reconditioning program (e.g., walking) and back education within the first post-procedure week, barring complications. Instruction and participation in a long-term home-based program of ROM, core strengthening, postural or neuromuscular re-education, endurance, and stability exercises should be accomplished over a period of 4 to 10 visits post-procedure.

v. Requirements for Repeat Radiofrequency SI Joint Neurotomy. In some cases, pain may recur. Successful RF neurotomy usually provides from 6 to 18 months of relief. Repeat neurotomy should only be performed if the initial procedure resulted in improved function for six months. There is no need for repeat Sacroiliac joint or lateral branch injection before RF. SI Joint fusion can be considered for those unable to return to function due to RF Sacral Lateral Branches that no longer last for six months.

## h. Trigger Point Injections

i. Description. Trigger point injections are generally accepted treatment. Trigger point treatment can consist of injection of local anesthetic, with or without corticosteroid, into highly localized, extremely sensitive bands of skeletal muscle fibers. These muscle fibers produce local and referred pain when activated. Medication is injected in a four-quadrant manner in the area of maximum tenderness. Injection can be enhanced if treatments are immediately followed by myofascial therapeutic interventions, such as vapo-coolant spray and stretch, ischemic pressure massage (myotherapy), specific soft tissue mobilization and physical modalities. There is conflicting

evidence regarding the benefit of trigger point injections. There is no evidence that injection of medications improves the results of trigger-point injections. Needling alone may account for some of the therapeutic response of injections. Needling must be performed by practitioners with the appropriate credentials in accordance with state and other applicable regulations.

(a). Conscious sedation for patients receiving trigger point injections may be considered. However, the patient must be alert to help identify the site of the injection.

ii. Indications. Trigger point injections may be used to relieve myofascial pain and facilitate active therapy and stretching of the affected areas. They are to be used as an adjunctive treatment in combination with other treatment modalities such as active therapy programs. Trigger point injections should be utilized primarily for the purpose of facilitating functional progress. Patients should continue in an aggressive aerobic and stretching therapeutic exercise program, as tolerated, while undergoing intensive myofascial interventions. Myofascial pain is often associated with other underlying structural problems. Any abnormalities need to be ruled out prior to injection.

iii. Trigger point injections are indicated in patients with consistently observed, well circumscribed trigger points. This demonstrates a local twitch response, characteristic radiation of pain pattern and local autonomic reaction, such as persistent hyperemia following palpation. Generally, trigger point injections are not necessary unless consistently observed trigger points are not responding to specific, noninvasive, myofascial interventions within approximately a six-week time frame. However, trigger point injections may be occasionally effective when utilized in the patient with immediate, acute onset of pain or in a post-operative patient with persistent muscle spasm or myofascial pain.

iv. Complications. Potential but rare complications of trigger point injections include infection, pneumothorax, anaphylaxis, penetration of viscera, neurapraxia, and neuropathy. If corticosteroids are injected in addition to local anesthetic, there is a risk of local myopathy. Severe pain on injection suggests the possibility of an intraneural injection, and the needle should be immediately repositioned.

v. Timing/Frequency/Duration

(a). Time to produce effect: Local anesthetic 30 minutes; 24 to 48 hours for no anesthesia;

(b). Frequency: no more than four injection sites per session per week for acute exacerbations only to avoid significant post-injection soreness;

(c). Optimum duration/Maximum duration: four sessions per year. Injections may only be repeated when the above functional and time goals are met.

i. Prolotherapy. Also known as sclerotherapy consists of a series of injections of hypertonic dextrose, with or without glycerine and phenol, into the ligamentous structures of the low back. Its proponents claim that the

inflammatory response to the injections will recruit cytokine growth factors involved in the proliferation of connective tissue, stabilizing the ligaments of the low back when these structures have been damaged by mechanical insults.

i. There are conflicting studies concerning the effectiveness of Prolotherapy in the low back. Lasting functional improvement has not been shown. The injections are invasive, may be painful to the patient, and are not generally accepted or widely used. Therefore, the use of Prolotherapy for low back pain is not recommended.

j. Basivertebral Nerve Ablation (BVN). This procedure is approved for a subgroup of chronic low back pain patients who have vertebrogenic-related symptomology.

i. Procedure is indicated if all of the following are met:

(a). Main symptom is low back pain, has had chronic low back pain for a minimum of 6 months, and patient is mature skeletally;

(b). Despite attempts at nonsurgical management, the patient has failed to satisfactorily improve; and

(c). Type 1 (hypointensity) or Type 2 (hyperintensity) Modic changes are reported at the endplates that are the suspected pain generators by the reading radiologist and/or treating physician. If MRI is contraindicated in the patient, a CT/SPET merge with increased uptake at the suspected endplate is acceptable.

ii. Procedure is not indicated if any of the following occurs:

(a). Patients has implantable pulse generators (pacemakers, defibrillators) or other electronic implants unless specific precautions are taken to maintain safety;

(b). Active systemic infection or spine infection;

(c). Severe cardiac or pulmonary compromise;

(d). Lumbar radiculopathy or radicular pain due to neurocompression (for example, HNP, stenosis), neurogenic claudication, as primary symptoms;

(e). Metabolic bone disease (for example, osteoporosis), trauma/compression fracture or spinal cancer, treatment of spine fragility fracture; or

(f). Evidence on imaging implies another cause for the patient's low back pain symptoms, including but not limited to degenerative scoliosis or facet arthropathy or effusion with clinically suspected facet joint pain, disc herniation, segmental instability, lumbar stenosis.

(g). Prior basivertebral denervation at the suspected level.

4. Epiduroscopy and Epidural Lysis of Adhesions: An investigational treatment of low back pain. It involves the introduction of a fiberoptic endoscope into the epidural space via the sacral hiatus. With cephalad advancement of the endoscope under direct visualization, the epidural space is irrigated with saline. Adhesiolysis may be done

mechanically with a fiberoptic endoscope. The saline irrigation is performed with or without epiduroscopy and is intended to distend the epidural space in order to obtain an adequate visual field. It is designed to produce lysis of adhesions, which are conjectured to produce symptoms due to traction on painful nerve roots. Saline irrigation is associated with risks of elevated pressures which may impede blood flow and venous return, possibly causing ischemia of the cauda equina and retinal hemorrhage.

a. Other complications associated with instrumented lysis include catheter shearing, need for catheter surgical removal, infection (including meningitis), hematoma, and possible severe hemodynamic instability during application. Although epidural adhesions have been postulated to cause chronic low back pain, studies have failed to find a significant correlation between the level of fibrosis and pain or difficulty functioning. Studies of epidural lysis demonstrate no transient pain relief from the procedure. Given the low likelihood of a positive response, the additional costs and time requirement, and the possible complications from the procedure, epidural injection, or mechanical lysis, is not recommended.

b. Epiduroscopy—directed steroid injections are also not recommended as there is no evidence to support an advantage for using an epiduroscope with steroid injections.

5. Medications/Pharmacy. Medication use in the treatment of low back injuries is appropriate for controlling acute and chronic pain and inflammation. Use of medications will vary widely due to the spectrum of injuries from simple strains to post-surgical healing. All drugs should be used according to patient needs. A thorough medication history, including use of alternative and over the counter medications, should be performed at the time of the initial visit and updated periodically. Treatment for pain control is initially accomplished with acetaminophen and/or NSAIDs. The patient should be educated regarding the interaction with prescription and over-the-counter medications as well as the contents of over-the-counter herbal products. The following are listed in alphabetical order:

a. Acetaminophen: is an effective analgesic with antipyretic but not anti-inflammatory activity. Acetaminophen is generally well tolerated, causes little or no gastrointestinal irritation, and is not associated with ulcer formation. Acetaminophen has been associated with liver toxicity in overdose situations or in chronic alcohol use. Patients may not realize that many over-the-counter preparations may contain acetaminophen. The total daily dose of acetaminophen is recommended not to exceed 2250 mg per 24-hour period, from all sources, including narcotic-acetaminophen combination preparations:

- i. optimum duration: 7 to 10 days;
- ii. maximum duration: chronic use as indicated on a case-by-case basis. Use of this substance long-term for 3 days per week or greater may be associated with rebound pain upon cessation.

b. Muscle Relaxants: are appropriate for muscle spasm with pain. There is strong evidence that muscle relaxants are more effective than placebo for providing short-term pain relief in acute low back pain. When prescribing these agents, physicians must seriously consider side effects of drowsiness or dizziness and the fact that benzodiazepines may be habit-forming.

- i. optimum duration: one week;
- ii. maximum duration: two weeks (or longer if used only at night).

c. Narcotics: should be primarily reserved for the treatment of severe low back pain. In mild to moderate cases of low back pain, narcotic medication should be used cautiously on a case-by-case basis. Adverse effects include respiratory depression, the development of physical and psychological dependence, and impaired alertness.

i. Narcotic medications should be prescribed with strict time, quantity, and duration guidelines, and with definitive cessation parameters. Pain is subjective in nature and should be evaluated using a scale to rate effectiveness of the narcotic prescribed. Any use beyond the maximum should be documented and justified based on the diagnosis and/or invasive procedures:

- (a). optimum duration: three to seven days;
- (b). maximum duration: two weeks. Use beyond two weeks is acceptable in appropriate cases. Refer to Chronic Pain Guidelines which gives a detailed discussion regarding medication use in chronic pain management.

(c). Nonsteroidal Anti-Inflammatory Drugs (NSAIDs) are useful for pain and inflammation. In mild cases, they may be the only drugs required for analgesia. There are several classes of NSAIDs, and the response of the individual injured worker to a specific medication is unpredictable. For this reason, a range of NSAIDs may be tried in each case with the most effective preparation being continued. Patients should be closely monitored for adverse reactions. The US Food and Drug Administration advise that many NSAIDs may cause an increased risk of serious cardiovascular thrombotic events, myocardial infarction, and stroke, which can be fatal. Naproxen sodium does not appear to be associated with increased risk of vascular events. Administration of proton pump inhibitors, Histamine 2 Blockers or prostaglandin analog misoprostol along with these NSAIDs may reduce the risk of duodenal and gastric ulceration but do not impact possible cardiovascular complications. Due to the cross-reactivity between aspirin and NSAIDs, NSAIDs should not be used in aspirin-sensitive patients, and should be used with caution in all asthma patients. NSAIDs are associated with abnormal renal function, including renal failure, as well as, abnormal liver function. Certain NSAIDs may have interactions with various other medications. Individuals may have adverse events not listed above. Intervals for metabolic screening are dependent upon the patient's age, general health status and should be within parameters listed for each specific medication. Complete Blood Count (CBC), and liver and

renal function should be monitored at least every six months in patients on chronic NSAIDs and initially when indicated.

(i). Non-Selective Nonsteroidal Anti-Inflammatory Drugs

[a]. Includes NSAIDs and acetylsalicylic acid (aspirin). Serious GI toxicity, such as bleeding, perforation, and ulceration can occur at any time, with or without warning symptoms in patients treated with traditional NSAIDs. Physicians should inform patients about the signs and/or symptoms of serious gastrointestinal toxicity and what steps to take if they occur. Anaphylactoid reactions may occur in patients taking NSAIDs. NSAIDs may interfere with platelet function. Fluid retention and edema have been observed in some patients taking NSAIDs.

[i]. optimal duration: one week;

[ii]. maximum duration: one year. Use of these substances long-term (three days per week or greater) is associated with rebound pain upon cessation.

[iii]. Selective Cyclo-oxygenase-2 (COX-2) Inhibitors

[b]. COX-2 inhibitors are more recent NSAIDs and differ in adverse side effect profiles from the traditional NSAIDs. The major advantages of selective COX-2 inhibitors over traditional NSAIDs are that they have less gastrointestinal toxicity and no platelet effects. COX-2 inhibitors can worsen renal function in patients with renal insufficiency, thus renal function may need monitoring.

[c]. COX-2 inhibitors should not be first-line for low risk patients who will be using an NSAID short term but are indicated in select patients for whom traditional NSAIDs are not tolerated. Serious upper GI adverse events can occur even in asymptomatic patients. Patients at high risk for GI bleed include those who use alcohol, smoke, are older than 65, take corticosteroids or anti-coagulants, or have a longer duration of therapy. Celecoxib is contraindicated in sulfonamide allergic patients.

[i]. Optimal Duration: 7 to 10 days.

[ii]. Maximum Duration: Chronic use is appropriate in individual cases. Use of these substances long-term (three days per week or greater) is associated with rebound pain upon cessation.

d. Oral Steroids: have limited use but are accepted in cases requiring potent anti-inflammatory drug effect. There is no evidence supporting oral steroids for patients with low back pain with or without radiculopathy and are not recommended.

e. Intravenous Steroids: the risks of permanent neurological damage from acute spinal cord compression generally outweigh the risks of pharmacologic side effects of steroids in an emergent situation.

f. Psychotropic/anti-anxiety/hypnotic agents may be useful for treatment of mild and chronic pain, dysesthesias, sleep disorders, and depression. Antidepressant medications, such as tricyclics and, Selective Serotonin

reuptake inhibitors (SSRIs) and norepinephrine reuptake inhibitors (SSNRIs) are useful for affective disorder and chronic pain management. Tricyclic antidepressants, in low dose, are useful for chronic pain but have more frequent side effects. Anti-anxiety medications should generally be limited to short-term use. Combinations of the above agents may be useful. As a general rule, providers (i.e., physician or medical psychologist) should access the patient's prior history of substance abuse or depression prior to prescribing any of these agents. Due to the habit-forming potential of the benzodiazepines and other drugs found in this class, they are not routinely recommended. Refer to the Chronic Pain Guidelines which give a detailed discussion regarding medication use in chronic pain management:

i. optimum duration: one to six months;

ii. maximum duration: 6 to 12 months, with monitoring.

g. Tramadol is useful in relief of low back pain and has been shown to provide pain relief equivalent to that of commonly prescribed NSAIDs. Although Tramadol may cause impaired alertness, it is generally well tolerated, does not cause gastrointestinal ulceration, or exacerbate hypertension or congestive heart failure. Tramadol should be used cautiously in patients who have a history of seizures or who are taking medication that may lower the seizure threshold, such as monoamine oxidase (MAO) inhibitors, SSRIs, and tricyclic antidepressants. This medication has physically addictive properties and withdrawal may follow abrupt discontinuation and is not recommended for those with prior opioid addiction.

i. optimum duration: three to seven days;

ii. maximum duration: two weeks. Use beyond two weeks is acceptable in appropriate cases.

h. Lofexidine (Lucremyra)

i. Description: Central Alpha 2 Agonist.

ii. Indications: mitigation of opioid withdrawal symptoms to facilitate abrupt opioid discontinuation in adults.

iii. Major Contraindications: severe coronary insufficiency, recent myocardial infarction, cerebrovascular disease, renal failure, marked bradycardia, or prolonged QT Syndrome.

iv. Dosing and Time to Therapeutic Effect: three 0.18mg tablets 4 times a day for 7 days.

v. Major Side Effects: insomnia, orthostatic hypotension, bradycardia, hypotension, dizziness, somnolence, sedation, dry mouth.

vi. Drug Interactions. Any medications that decrease pulse or blood pressure to avoid the risk of excessive bradycardia and hypotension.

vii. Laboratory Monitoring. Monitor ECG in patients with congestive heart failure, bradyarrhythmias,

hepatic impairment, renal impairment, or patients taking other medicinal products that lead to QT Prolongation.

## 6. Occupational Rehabilitation Programs

a. **Non-Interdisciplinary.** These generally accepted programs are work-related, outcome-focused, individualized treatment programs. Objectives of the program include, but are not limited to, improvement of cardiopulmonary and neuromusculoskeletal functions (strength, endurance, movement, flexibility, stability, and motor control functions), patient education, and symptom relief. The goal is for patients to gain full or optimal function and return to work. The service may include the time-limited use of passive modalities with progression to active treatment and/or simulated/real work.

### i. Work Conditioning

(a). These programs are usually initiated once reconditioning has been completed but may be offered at any time throughout the recovery phase. Work conditioning should be initiated when imminent return of a patient to modified or full duty is not an option, but the prognosis for returning the patient to work at completion of the program is at least fair to good:

- (i). length of visit: one to two hours per day;
- (ii). frequency: two to five visits per week;
- (iii). optimum duration: two to four weeks
- (iv). maximum duration: six weeks.

Participation in a program beyond six weeks must be documented with respect to need and the ability to facilitate positive symptomatic or functional gains.

### ii. Work Simulation

(a). Work simulation is a program where an individual completes specific work-related tasks for a particular job and return to work. Use of this program is appropriate when modified duty can only be partially accommodated in the work place, when modified duty in the work place is unavailable, or when the patient requires more structured supervision. The need for work place simulation should be based upon the results of a Functional Capacity Evaluation and/or Jobsite Analysis.

- (i). length of visit: two to six hours per day;
- (ii). frequency: two to five visits per week;
- (iii). optimum duration: two to four weeks;
- (iv). maximum duration: six weeks.

Participation in a program beyond six weeks must be documented with respect to need and the ability to facilitate positive symptomatic or functional gains.

(b). **Interdisciplinary:** programs are well-established treatment for patients with sub-acute and functionally impairing low back pain. They are characterized by a variety of disciplines that participate in the assessment, planning, and/or implementation of an injured worker's program with the goal for patients to gain full or optimal

function and return to work. There should be close interaction and integration among the disciplines to ensure that all members of the team interact to achieve team goals. Programs should include cognitive-behavioral therapy as there is good evidence for its effectiveness in patients with chronic low back pain. These programs are for patients with greater levels of disability, dysfunction, de-conditioning and psychological involvement. For patients with chronic pain, refer to the OWCA's Chronic Pain Disorder Medical Treatment Guidelines.

### (i). Work Hardening

[a]. Work Hardening is an interdisciplinary program addressing a patient's employability and return to work. It includes a progressive increase in the number of hours per day that a patient completes work simulation tasks until the patient can tolerate a full workday. This is accomplished by addressing the medical, psychological, behavioral, physical, functional, and vocational components of employability and return-to-work.

[b]. This can include a highly structured program involving a team approach or can involve any of the components thereof. The interdisciplinary team should, at a minimum, be comprised of a qualified medical director who is board certified with documented training in occupational rehabilitation; team physicians having experience in occupational rehabilitation; occupational therapist; physical therapist; case manager; and psychologist. As appropriate, the team may also include: chiropractor, RN, vocational specialist or Certified Biofeedback Therapist:

- [i]. length of visit: Up to 8 hours/day;
- [ii]. frequency: two to five visits per week;
- [iii]. optimum duration: two to four weeks;
- [iv]. maximum duration: six weeks.

Participation in a program beyond six weeks must be documented with respect to need and the ability to facilitate positive symptomatic or functional gains.

### (ii). Spinal Cord Programs

[a]. Spinal Cord Systems of Care provide coordinated, case-managed, and integrated service for people with spinal cord dysfunction, whether due to trauma or disease. The system includes an inpatient component in an organization licensed as a hospital and an outpatient component. Each component endorses the active participation and choice of the persons served throughout the entire program. The Spinal Cord System of Care also provides or formally links with key components of care that address the lifelong needs of the persons served.

[b]. This can include a highly structured program involving a team approach or can involve any of the components thereof. The interdisciplinary team should, at a minimum, be comprised of a qualified medical director who is board certified and trained in rehabilitation, a case manager, occupational therapist, physical therapist,



psychologist, rehabilitation RN and MD, and therapeutic recreation specialist. As appropriate, the team may also include: rehabilitation counselor, respiratory therapist, social worker, or speech-language pathologist.

[c]. Timeframe durations for any spinal cord program should be determined based upon the extent of the patient's injury and at the discretion of the rehabilitation physician in charge.

#### 7. Orthotics

a. Foot Orthoses and Inserts are accepted interventions for spinal disorders that are due to aggravated mechanical abnormalities, such as leg length discrepancy, scoliosis, or lower extremity misalignment. Shoe insoles or inserts may be effective for patients with acute low back problems who stand for prolonged periods of time.

b. Lumbar support devices include backrests for chairs and car seats. Lumbar supports may provide symptomatic relief of pain and movement reduction in cases of chronic low back problems.

c. Lumbar Corsets and Back Belts. There is insufficient evidence to support their use

d. Lumbosacral Bracing. Rigid bracing devices are well accepted and commonly used for post-fusion, scoliosis, and vertebral fractures.

8. Patient Education. No treatment plan is complete without addressing issues of individual and/or group patient education as a means of prolonging the beneficial effects of treatment, as well as facilitating self-management of symptoms and injury prevention. The patient should be encouraged to take an active role in the establishment of functional outcome goals. They should be educated on their specific injury, assessment findings, and plan of treatment. Instruction on proper body mechanics and posture, positions to avoid, self-care for exacerbation of symptoms, and home exercise should also be addressed:

a. time to produce effect: varies with individual patient;

b. frequency: should occur at every visit.

9. Personality/Psychological/Psychiatric/ Psychosocial Intervention. Psychosocial treatment is generally accepted, widely used, and well-established Intervention. This group of therapeutic and diagnostic modalities includes, but is not limited to, individual counseling, group therapy, stress management, psychosocial crises intervention, hypnosis, and meditation. Any evaluation or diagnostic workup should clarify and distinguish between pre-existing versus aggravated versus purely causative psychological conditions. Psychosocial intervention is recommended as an important component in the total management program that should be implemented as soon as the problem is identified. There is some evidence that early cognitive-behavioral treatment reduces health care use in comparison to written information alone. This can be used alone, or in conjunction with other treatment modalities. Providers treating patients with chronic

pain should refer to the OWCA's Chronic Pain Disorder Medical Treatment Guidelines:

a. time to produce effect: two to four weeks;

b. frequency: one to three times weekly for the first four weeks (excluding hospitalization, if required), decreasing to one to two times per week for the second month. Thereafter, two to four times monthly;

c. optimum duration: six weeks to three months;

d. maximum duration: 3 to 12 months. Counseling is not intended to delay but to enhance functional recovery. For select patients, longer supervised treatment may be required and if further counseling beyond three months is indicated, extensive documentation addressing which pertinent issues are pre-existing versus aggravated versus causative, as well as projecting a realistic functional prognosis, should be provided by the authorized treating provider every four to six weeks during treatment.

10. Restriction of Activities. Continuation of normal daily activities is the recommendation for acute and chronic low back pain without neurologic symptoms. There is good evidence against the use of bed rest in cases without neurologic symptoms. Bed rest may lead to de-conditioning and impair rehabilitation. Complete work cessation should be avoided, if possible, since it often further aggravates the pain presentation. Modified return-to-work is almost always more efficacious and rarely contraindicated in the vast majority of injured workers with low back pain.

11. Return-to-Work. Early return-to-work should be a prime goal in treating occupational injuries given the poor return-to-work prognosis for an injured worker who has been out of work for more than six months. It is imperative that the patient be educated regarding the benefits of return-to-work, work restrictions, and follow-up if problems arise. When attempting to return a patient to work after a specific injury, clear objective restrictions of activity level should be made. An accurate job description with detailed physical duty restrictions is often necessary to assist the physician in making return-to-work recommendations. This may require a jobsite evaluation.

a. Employers should be prepared to offer transitional work. This may consist of temporary work in a less demanding position, return to the regular job with restrictions, or gradual return to the regular job. Company policies which encourage return-to-work with positive communication are most likely to have decreased worker disability.

b. Return-to-work is defined as any work or duty that the patient is able to perform safely. It may not be the patient's regular work. Due to the large spectrum of injuries of varying severity and varying physical demands in the work place, it is not possible to make specific return-to-work guidelines for each injury. Therefore, the OWCA recommends the following.

c. Establishment of a Return-To-Work Status: Ascertaining a return-to-work status is part of medical care,

should be included in the treatment and rehabilitation plan, and addressed at every visit. A description of daily activity limitations is part of any treatment plan and should be the basis for restriction of work activities. In most non-surgical cases, the patient should be able to return-to-work in some capacity or in an alternate position consistent with medical treatment within several days unless there are extenuating circumstances. Injuries requiring more than two weeks off work should be thoroughly documented.

d. Establishment of Activity Level Restrictions. Communication is essential between the patient, employer, and provider to determine appropriate restrictions and return-to-work dates. It is the responsibility of the physician to provide clear concise restrictions, and it is the employer's responsibility to determine if temporary duties can be provided within the restrictions. For low back pain injuries, the following should be addressed when describing the patient's activity level:

i. lifting limits with the maximum amount of weight to be lifted. This may vary depending on the frequency of the lifting and/or the object height level. Pushing, pulling, as well as bending and twisting at the waist should be considered as well;

ii. lower body postures such as squatting, kneeling, crawling, stooping, awkward or static positions, and climbing ladders or stairs should include duration and frequency;

iii. ambulatory level for distance, frequency, and terrain should be specified;

iv. duration and frequency of sitting, standing, and walking should be delineated. Balance issues should also be considered in these determinations;

v. use of adaptive devices or equipment for proper office ergonomics to enhance capacities can be included;

vi. the effect of any medications that may pose a safety risk to the patient, co-workers or the general public should be considered with regard to the workplace and home.

e. Compliance with Activity Restrictions: In some cases, compliance with restriction of activity levels may require a complete jobsite evaluation, a functional capacity evaluation (FCE) or other special testing. Refer to the "Special Tests" section of this guideline.

12. Therapy—Active. The following active therapies are widely used and accepted methods of care for a variety of work-related injuries. They are based on the philosophy that therapeutic exercise and/or activity are beneficial for restoring flexibility, strength, endurance, function, range of motion, and can alleviate discomfort. Active therapy requires an internal effort by the individual to complete a specific exercise or task. This form of therapy requires supervision from a therapist or medical provider such as verbal, visual, and/or tactile instruction(s). At times, the provider may help stabilize the patient or guide the movement pattern but the

energy required to complete the task is predominately executed by the patient.

a. On occasion, specific diagnoses and post-surgical conditions may warrant durations of treatment beyond those listed as "maximum". Factors such as exacerbation of symptoms, re-injury, interrupted continuity of care and comorbidities may also extend durations of care. Specific goals with objectively measured functional improvement during treatment must be cited to justify extended durations of care. It is recommended that, if no functional gain is observed after the number of treatments under "time to produce effect" has been completed alternative treatment interventions, further diagnostic studies or further consultations should be pursued.

b. Patients should be instructed to continue active therapies at home as an extension of the treatment process in order to maintain improvement levels. Follow-up visits to reinforce and monitor progress and proper technique are recommended. Home exercise can include exercise with or without mechanical assistance or resistance and functional activities with assistive devices. The following active therapies are listed in alphabetical order:

c. Activities of daily living (ADL) are well-established interventions which involve instruction, active-assisted training, and/or adaptation of activities or equipment to improve a person's capacity in normal daily activities such as self-care, work re-integration training, homemaking, and driving.

i. time to produce effect: four to five treatments;

ii. frequency: three to five times per week;

iii. optimum duration: four to six weeks;

iv. maximum duration: six weeks.

d. Aquatic Therapy is a well-accepted treatment which consists of the therapeutic use of aquatic immersion for therapeutic exercise to promote strengthening, core stabilization, endurance, range of motion, flexibility, body mechanics, and pain management. Aquatic therapy includes the implementation of active therapeutic procedures in a swimming or therapeutic pool. The water provides a buoyancy force that lessens the amount of force gravity applies to the body. The decreased gravity effect allows the patient to have a mechanical advantage and more likely have a successful trial of therapeutic exercise. The therapy may be indicated for individuals who:

i. cannot tolerate active land-based or full-weight bearing therapeutic procedures;

ii. require increased support in the presence of proprioceptive deficit;

iii. are at risk of compression fracture due to decreased bone density;

iv. have symptoms that are exacerbated in a dry environment;

v. would have a higher probability of meeting active therapeutic goals than in a dry environment.

(a). The pool should be large enough to allow full extremity range of motion and fully erect posture. Aquatic vests, belts and other devices can be used to provide stability, balance, buoyancy, and resistance:

- (i). time to produce effect: four to five treatments;
- (ii). frequency: three to five times per week;
- (iii). optimum duration: four to six weeks;
- (iv). maximum duration: eight weeks;

(b). A self-directed program is recommended after the supervised aquatics program has been established, or, alternatively a transition to a self-directed dry environment exercise program.

e. Functional activities are well-established interventions which involve the use of therapeutic activity to enhance mobility, body mechanics, employability, coordination, balance, and sensory motor integration.

- i. time to produce effect: four to five treatments;
- ii. frequency: three to five times per week;
- iii. optimum duration: four to six weeks;
- iv. maximum duration: six weeks.

f. Functional electrical stimulation is an accepted treatment in which the application of electrical current to elicit involuntary or assisted contractions of atrophied and/or impaired muscles. It may be indicated for muscle atrophy due to radiculopathy:

- i. time to produce effect: two to six treatments;
- ii. frequency: three times per week;
- iii. optimum duration: eight weeks;
- iv. maximum duration: eight weeks. If beneficial, provide with home unit.

g. Neuromuscular re-education is a generally accepted treatment. It is the skilled application of exercise with manual, mechanical, or electrical facilitation to enhance strength; movement patterns; neuromuscular response; proprioception, kinesthetic sense, coordination; education of movement, balance, and posture. Indications include the need to promote neuromuscular responses through carefully timed proprioceptive stimuli, to elicit and improve motor activity in patterns similar to normal neurologically developed sequences, and improve neuromotor response with independent control:

- i. time to produce effect: two to six treatments;
- ii. frequency: three times per week;
- iii. optimum duration: four to eight weeks;
- iv. maximum duration: eight weeks.

h. Spinal stabilization is a generally well-accepted treatment. The goal of this therapeutic program is to strengthen the spine in its neural and anatomic position. The stabilization is dynamic which allows whole body movements while maintaining a stabilized spine. It is the ability to move and function normally through postures and activities without creating undue vertebral stress:

- i. time to produce effect: four to eight treatments;
- ii. frequency: three to five times per week;
- iii. optimum duration: four to eight weeks;
- iv. maximum duration: eight weeks.

i. Therapeutic exercise is a generally well-accepted treatment. There is some evidence to support the effectiveness of yoga therapy in alleviating symptoms and decreasing medication use in uncomplicated low back pain. Therapeutic exercise, with or without mechanical assistance or resistance, may include isoinertial, isotonic, isometric and isokinetic types of exercises. Indications include the need for cardiovascular fitness, reduced edema, improved muscle strength, improved connective tissue strength and integrity, increased bone density, promotion of circulation to enhance soft tissue healing, improvement of muscle recruitment, improved proprioception, and coordination, increased range of motion. Therapeutic exercises are used to promote normal movement patterns, and can also include complementary/alternative exercise movement therapy (with oversight of a physician or appropriate healthcare professional):

- i. time to produce effect: two to six treatments;
- ii. frequency: three to five times per week;
- iii. optimum duration: four to eight weeks;
- iv. maximum duration: eight weeks.

13. Therapy—passive. Most of the following passive therapies and modalities are generally accepted methods of care for a variety of work-related injuries. Passive therapy includes those treatment modalities that do not require energy expenditure on the part of the patient. They are principally effective during the early phases of treatment and are directed at controlling symptoms such as pain, inflammation and swelling and to improve the rate of healing soft tissue injuries. They should be used adjunctively with active therapies such as postural stabilization and exercise programs to help control swelling, pain, and inflammation during the active rehabilitation process. Please refer to General Guideline Principles, Active Interventions. Passive therapies may be used intermittently as a therapist deems appropriate or regularly if there are specific goals with objectively measured functional improvements during treatment.

a. On occasion, specific diagnoses and post-surgical conditions may warrant durations of treatment beyond those listed as "maximum." factors such as exacerbation of symptoms, re-injury, interrupted continuity of care, and comorbidities may also extend durations of care. Specific

goals with objectively measured functional improvement during treatment must be cited to justify extended durations of care. It is recommended that, if no functional gain is observed after the number of treatments under “time to produce effect” have been completed, alternative treatment interventions, further diagnostic studies, or further consultations should be pursued.

b. The following passive therapies are listed in alphabetical order.

i. Electrical stimulation (unattended) is an accepted treatment. Once applied, unattended electrical stimulation requires minimal on-site supervision by the physical therapist, occupational therapist, or other provider. Indications include pain, inflammation, muscle spasm, atrophy, decreased circulation, and the need for osteogenic stimulation. A home unit should be purchased if treatment is effective and frequent use is recommended:

(a). time to produce effect: two to four treatments;

(b). frequency: Varies, depending upon indication, between two to three times/day to one time/week. Home unit should be purchased if treatment is effective and frequent use is recommended;

(c). optimum duration: four treatments for clinic use;

(d). maximum duration: eight treatments for clinic use.

ii. Iontophoresis is an accepted treatment which consists of the transfer of medication, including, but not limited to, steroidal anti-inflammatories and anesthetics, through the use of electrical stimulation. Indications include pain (Lidocaine), inflammation (hydrocortisone, salicylate), edema (mecholy, hyaluronidase, salicylate), ischemia (magnesium, mecholy, iodine), muscle spasm (magnesium, calcium), calcific deposits (acetate), scars, and keloids (sodium chloride, iodine, acetate). There is no proven benefit for this therapy in the low back:

(a). time to produce effect: one to four treatments;

(b). frequency: three times per week with at least 48 hours between treatments;

(c). optimum duration: four to six weeks;

(d). maximum duration: six weeks.

iii. Manipulation is generally accepted, well-established and widely used therapeutic intervention for low back pain. Manipulative Treatment (not therapy) is defined as the therapeutic application of manually guided forces by an operator to improve physiologic function and/or support homeostasis that has been altered by the injury or occupational disease, and has associated clinical significance.

(a). High velocity, low amplitude (HVLA) technique, chiropractic manipulation, osteopathic

manipulation, muscle energy techniques, counter strain, and non-force techniques are all types of manipulative treatment. This may be applied by osteopathic physicians (D.O.), chiropractors (D.C.), properly trained physical therapists (P.T.), properly trained occupational therapists (O.T.), or properly trained medical physicians. Under these different types of manipulation exist many subsets of different techniques that can be described as direct- a forceful engagement of a restrictive/pathologic barrier; indirect- a gentle/non-forceful disengagement of a restrictive/pathologic barrier; the patient actively assists in the treatment; and the patient relaxing, allowing the practitioner to move the body tissues. When the proper diagnosis is made and coupled with the appropriate technique, manipulation has no contraindications and can be applied to all tissues of the body. Pre-treatment assessment should be performed as part of each manipulative treatment visit to ensure that the correct diagnosis and correct treatment is employed.

(b). High velocity, low amplitude (HVLA) manipulation is performed by taking a joint to its end range of motion and moving the articulation into the zone of accessory joint movement, well within the limits of anatomical integrity. There is good scientific evidence to suggest that HVLA manipulation can be helpful for patients with acute low back pain problems without radiculopathy when used within the first four to six weeks of symptoms. Although the evidence for sub-acute and chronic low back pain and low back pain with radiculopathy is less convincing, it is a generally accepted and well-established intervention for these conditions. Indications for manipulation include joint pain, decreased joint motion, and joint adhesions. Contraindications to HVLA manipulation include joint instability, fractures, severe osteoporosis, infection, metastatic cancer, active inflammatory arthritides, aortic aneurysm, and signs of progressive neurologic deficits.

(c.). Manipulation/Grade I - V:

(i). time to produce effect for all types of manipulative treatment: one to six treatments;

(ii). frequency: Up to three times per week for the first four weeks as indicated by the severity of involvement and the desired effect, then up to two treatments per week for the next four weeks. For further treatments, twice per week or less to maintain function;

(iii). optimum duration: 8 to 12 weeks;

(iv). maximum duration: three months. Extended durations of care beyond what is considered “maximum” may be necessary in cases of re-injury, interrupted continuity of care, exacerbation of symptoms, and in those patients with comorbidities. Refer to the Chronic Pain Guidelines for care beyond three months.

(d). Manipulation under general anesthesia (MUA) refers to manual manipulation of the lumbar spine in combination with the use of a general anesthetic or conscious sedation. It is intended to improve the success of

manipulation when pain, muscle spasm, guarding, and fibrosis appear to be limiting its application in patients otherwise suitable for their use. There have been no high quality studies to justify its benefits given the risks of general anesthetic and conscious sedation. It is not recommended.

(e). Manipulation under joint anesthesia (MUJA) refers to manipulation of the lumbar spine in combination with a fluoroscopically guided injection of anesthetic with or without corticosteroid agents into the facet joint at the level being manipulated. There are no controlled clinical trials to support its use. It is not recommended.

iv. Massage—Manual or Mechanical. Massage is manipulation of soft tissue with broad ranging relaxation and circulatory benefits. This may include stimulation of acupuncture points and acupuncture channels (acupressure), application of suction cups and techniques that include pressing, lifting, rubbing, pinching of soft tissues by, or with, the practitioner's hands. Indications include edema (peripheral or hard and non-pliable edema), muscle spasm, adhesions, the need to improve peripheral circulation and range of motion, or to increase muscle relaxation and flexibility prior to exercise.

(a). In sub-acute low back pain populations there is good evidence that massage can increase function when combined with exercise and patient education. Some studies have demonstrated a decrease in provider visits and pain medication use with combined therapy. One study indicated improved results with acupressure massage. It is recommended that all massage be performed by trained, experienced therapists and be accompanied by an active exercise program and patient education. In contrast to the sub-acute population, massage is a generally accepted treatment for the acute low back pain population, although no studies have demonstrated its efficacy for this set of patients:

- (i). time to produce effect: immediate;
- (ii). frequency: one to two times per week;
- (iii). optimum duration: six weeks;
- (iv). maximum duration: two months.

v. Mobilization (joint) is a generally well-accepted treatment. Mobilization is passive movement involving oscillatory motions to the vertebral segment(s). The passive mobility is performed in a graded manner (I, II, III, IV, or V), which depicts the speed and depth of joint motion during the maneuver. For further discussion on Level V joint mobilization please see section on HVLA manipulation [Refer to Clause 12.c.ii.]. It may include skilled manual joint tissue stretching. Indications include the need to improve joint play, segmental alignment, improve intracapsular arthrokinematics, or reduce pain associated with tissue impingement. Mobilization should be accompanied by active therapy. For Level V mobilization contraindications include joint instability, fractures, severe osteoporosis, infection, metastatic cancer, active inflammatory arthritides, aortic aneurysm, and signs of progressive neurologic deficits:

- (a). time to produce effect: six to nine treatments;
- (b). frequency: up to three times per week;
- (c). optimum duration: four to six weeks;
- (d). maximum duration: six weeks.

vi. Mobilization (soft tissue): is a generally well-accepted treatment. Mobilization of soft tissue is the skilled application of muscle energy, strain/counter strain, myofascial release, manual trigger point release, and manual therapy techniques designed to improve or normalize movement patterns through the reduction of soft tissue pain and restrictions. These can be interactive with the patient participating or can be with the patient relaxing and letting the practitioner move the body tissues. Indications include muscle spasm around a joint, trigger points, adhesions, and neural compression. Mobilization should be accompanied by active therapy:

- (a). time to produce effect: four to nine treatments;
- (b). frequency: up to three times per week;
- (c). optimum duration: four to six weeks;
- (d). maximum duration: six weeks.

vii. Intramuscular Manual Therapy: Dry Needling. IMT involves using filament needles to treat "trigger points" within muscle. It may require multiple advances of a filament needle to achieve a local twitch response to release muscle tension and pain. Dry needling is an effective treatment for acute and chronic pain of neuropathic origin with very few side effects. Dry needling is a technique to treat the neuro-musculoskeletal system based on pain patterns, muscular dysfunction and other orthopedic signs and symptoms:

- (a). time to produce effect: immediate
- (b). frequency: one to two times a week
- (c). optimum duration: six weeks
- (d). maximum duration: two months

viii. Short-wave diathermy is an accepted treatment which involves the use of equipment that exposes soft tissue to a magnetic or electrical field. Indications include enhanced collagen extensibility before stretching, reduced muscle guarding, reduced inflammatory response, and enhanced re-absorption of hemorrhage/hematoma or edema.

- (a). time to produce effect: two to four treatments;
- (b). frequency: two to three times per week up to three weeks;
- (c). optimum duration: three to five weeks;
- (d). maximum duration: five weeks.

ix. Superficial Heat and Cold Therapy (excluding Infrared Therapy) is a generally accepted treatment.

Superficial heat and cold are thermal agents applied in various manners that lower or raise the body tissue temperature for the reduction of pain, inflammation, and/or effusion resulting from injury or induced by exercise. It includes application of heat just above the surface of the skin at acupuncture points. Indications include acute pain, edema and hemorrhage, need to increase pain threshold, reduce muscle spasm, and promote stretching/flexibility. Cold and heat packs can be used at home as an extension of therapy in the clinic setting. Continuous cryotherapy units with compression are allowable in post-surgical orthopedic patients.

- (a). time to produce effect: Immediate;
- (b). frequency: two to five times per week;
- (c). maximum duration: thirty days

x. Traction—manual is an accepted treatment and an integral part of manual manipulation or joint mobilization. Indications include decreased joint space, muscle spasm around joints, and the need for increased synovial nutrition and response. Manual traction is contraindicated in patients with tumor, infection, fracture, or fracture dislocation:

- (a). time to produce effect: one to three sessions;
- (b). frequency: two to three times per week;
- (c). optimum duration: 30 days;
- (d). maximum duration: one month.

xi. Traction—Mechanical. There is no evidence that mechanical traction is useful for low back pain patients without radicular symptoms. Therefore, it is not recommended in this population. It may be trialed in patients with radicular findings, and if successful, should be shifted to home traction. Traction modalities are contraindicated in patients with tumor, infections, fracture, or fracture dislocation. Non-oscillating inversion traction methods are contraindicated in patients with glaucoma or hypertension. A home lumbar traction unit can be purchased if therapy proves effective:

- (a). time to produce effect: one to three sessions up to 30 minutes. If response is negative after three treatments, discontinue this modality;
- (b). frequency: two to three times per week. A home lumbar traction unit can be purchased if therapy proves effective;
- (c). optimum duration: four weeks;
- (d). maximum duration: four weeks.

xii. Transcutaneous electrical nerve stimulation (TENS) is a generally accepted treatment. TENS should include at least one instructional session for proper application and use. Indications include muscle spasm, atrophy, and decreased circulation and pain control. Minimal TENS unit parameters should include pulse rate, pulse width and amplitude modulation. Consistent, measurable

functional improvement must be documented prior to the purchase of a home unit:

- (a). time to produce effect: immediate;
- (b). frequency: variable;
- (c). optimum duration: three sessions;
- (d). maximum duration: three sessions. If beneficial, provide with home unit or purchase if effective.

xiii. Ultrasound (including phonophoresis) is an accepted treatment. Ultrasound uses sonic generators to deliver acoustic energy for therapeutic thermal and/or non-thermal soft tissue effects. Indications include scar tissue, adhesions, collagen fiber and muscle spasm, and the need to extend muscle tissue or accelerate the soft tissue healing. Ultrasound with electrical stimulation is concurrent delivery of electrical energy that involves dispersive electrode placement. Indications include muscle spasm, scar tissue, pain modulation, and muscle facilitation.

(a). Phonophoresis is the transfer of medication to the target tissue to control inflammation and pain through the use of sonic generators. These topical medications include, but are not limited to, steroidal anti-inflammatory and anesthetics:

- (i). time to produce effect: 6 to 15 treatments;
- (ii). frequency: three times per week;
- (iii). optimum duration: four to eight weeks;
- (iv). maximum duration: eight weeks.

xiv. Vertebral axial decompression (VAX-D)/DRX, 9000 Motorized traction devices which purport to produce non-surgical disc decompression by creating negative intradiscal pressure in the disc space include devices with the trade names of VAX-D and DRX 9000. There are no good studies to support their use. They are not recommended.

xv. Whirlpool/hubbard tank is a generally accepted treatment in which conductive exposure to water at varied temperatures that best elicits the desired effect. It generally includes massage by water propelled by a turbine or Jacuzzi jet system and has the same thermal effects as hot packs, if water temperature exceeds tissue temperature. It has the same thermal effects as cold application, if comparable temperature water is used. Indications include the need for analgesia, relaxing muscle spasm, reducing joint stiffness, and facilitating and preparing for exercise:

- (a). time to produce effect: two to four treatments
- (b). frequency: three to five times per week
- (c). optimum duration: three weeks as primary, or intermittently as an adjunct to other therapeutic procedures up to two months;
- (d). maximum duration: two months.

14. Vocational rehabilitation is a generally accepted intervention. Initiation of vocational rehabilitation requires adequate evaluation of patients for quantification highest functional level, motivation, and achievement of maximum medical improvement. Vocational rehabilitation may be as simple as returning to the original job or as complicated as being retrained for a new occupation.

a. It may also be beneficial for full vocational rehabilitation to be started before MMI if it is evident that the injured worker will be unable to return to his/her previous occupation. A positive goal and direction may aid the patient in decreasing stress and depression and promote optimum rehabilitation.

AUTHORITY NOTE: Promulgated in accordance with R.S. 23:1203.1.

HISTORICAL NOTE: Promulgated by the Louisiana Workforce Commission, Office of Workers Compensation Administration, LR 37:1664 (June 2011), amended by the Louisiana Workforce Commission, Office of Workers Compensation, LR 40:1140 (June 2014), LR 46:1452 (September 2020), LR 49:520 (March 2023), LR 50:692 (May 2024).

### **§2023. Therapeutic Procedures—Operative**

A. All operative interventions must be based upon positive correlation of clinical findings, clinical course, and diagnostic tests. A comprehensive assimilation of these factors must lead to a specific diagnosis with positive identification of pathologic condition(s). It is imperative to rule out non-physiologic modifiers of pain presentation or non-operative conditions mimicking radiculopathy or instability (e.g., peripheral neuropathy, piriformis syndrome, myofascial pain, scleratogenous or sympathetically mediated pain syndromes, sacroiliac dysfunction, psychological conditions, etc.) prior to consideration of elective surgical intervention.

B. Operative treatment is indicated when the natural history of surgically treated lesions is better than the natural history for non-operatively treated lesions. All patients being considered for surgical intervention should first undergo a comprehensive neuro-musculoskeletal examination to identify mechanical pain generators that may respond to non-surgical techniques or may be refractory to surgical intervention.

C. While sufficient time allowances for non-operative treatment are required to determine the natural cause and response to non-operative treatment of low back pain disorders, timely decision making for operative intervention is critical to avoid de-conditioning and increased disability (exclusive of "emergent" or urgent pathology such as cauda equina syndrome or associated rapidly progressive neurologic loss).

1. In general, if the program of non-operative treatment fails, operative treatment is indicated when:

a. Improvement of the symptoms has plateaued and the residual symptoms of pain and functional disability are unacceptable at the end of 6 to 12 weeks of active treatment, or at the end of longer duration of non-operative programs for debilitated patients with complex problems; and/or

b. Frequent recurrences of symptoms cause serious functional limitations even if a non-operative active treatment program provides satisfactory relief of symptoms, and restoration of function on each recurrence.

c. Mere passage of time with poorly guided treatment is not considered an active treatment program.

2. Referral for surgical evaluation and treatment. Consultation should be made to an appropriate surgical specialist for surgical evaluation and treatment when operative treatment is considered.

a. The decision and recommendation for operative treatment, and the appropriate informed consent should be made by the operating surgeon.

b. Prior to surgical intervention, the patient and treating physician should identify functional operative goals and the likelihood of achieving improved ability to perform activities of daily living or work activities and the patient should agree to comply with the pre- and post-operative treatment plan and home exercise requirements. The patient should understand the length of partial and full disability expected post-operatively.

D. Surgical workup and implementation for simple decompression of patients with herniated nucleus pulposus and sciatica should occur within 6 to 12 weeks after injury at the latest, within the above stated contingencies. For patients with true, refractory mechanical low back pain in whom fusion is being considered, it is recommended that a decisive commitment to surgical or non-surgical interventions occur within 5 months following injury, at the latest.

E. Spinal decompression surgeries and fusion have re-operation rates of approximately 10 percent or more over the following five years. Re-operation is indicated only when the functional outcome following the re-operation is expected to be better, within a reasonable degree of certainty, than the outcome of other non-invasive or less invasive treatment procedures. "Functional outcomes" refer to the patient's ability to improve functional tolerances such as sitting, standing, walking, strength, endurance, and/or vocational status. While timely surgical decision-making is critical to avoid de-conditioning and increased disability, a time limited trial of reconditioning should be tried prior to re-operation. Re-operation has a high rate of complications and failure and may lead to disproportionately increased disability.

F. Every post-operative patient should be involved in an active treatment program. (Refer to Therapeutic Procedures-Non-Operative. Interdisciplinary interventions should be strongly considered post-operatively in any patient not making functional progress within expected time frames. (Refer to Interdisciplinary Programs) Return to work restrictions should be specific according to the recommendations in Return to Work. Most non-fusion surgical patients can return to a limited level of duty between 3 to 6 weeks. Full activity is generally achieved between 6 weeks to 6 months depending on the procedure and healing of the individual.

## G. Lumbar Operative Procedures and Conditions

### 1. Discectomy

a. Description: To enter into and partially remove the disc.

b. Complications. Appropriate medical disclosures should be provided to the patient as deemed necessary by the physician.

c. Surgical Indications. To include all of the following: Primary radicular symptoms, radiculopathy on exam, correlating imaging study, and failure of non-surgical care. There is good evidence that surgery provides initial improvement of radicular symptoms with respect to chronic low back pain. There is conflicting evidence that the long-term outcome differs from that of the natural history of healing.

d. Operative Treatment: Partial Discectomy and Root Decompression

e. Post-Operative Therapy. A formal physical therapy program should be implemented post-operatively. Active treatment, which patients should have had prior to surgery, will frequently require a repeat of the sessions previously ordered.

### 2. Percutaneous Discectomy

a. Description. Percutaneous discectomy is an invasive operative procedure to accomplish partial removal of the disc through a needle which allows aspiration of a portion of the disc trocar under imaging control.

b. Complications. Appropriate medical disclosures should be provided to the patient as deemed necessary by the treating physician.

c. Surgical Indications. Percutaneous discectomy is indicated only in cases of suspected septic discitis in order to obtain diagnostic tissue. The procedure is not recommended for contained disc herniations or bulges with associated radiculopathy due to lack of evidence to support long-term improvement.

d. Operative Treatment: Partial Discectomy

### 3. Laminotomy/Laminectomy/Foramenotomy/Facetectomy

a. Description. These procedures provide access to produce neural decompression by partial or total removal of various parts of vertebral bone.

b. Complications. Appropriate medical disclosures should be provided to the patient as deemed necessary by the treating physician.

c. Surgical Indications include all of the following: Primary radicular symptoms, radiculopathy and radiculitis on exam, correlating imaging study, and failure of non-surgical care.

d. Operative Treatment. Laminotomy, and/or partial discectomy and root decompression.

e. Post-Operative Therapy. A formal physical therapy program should be implemented post-operatively. Active treatment, which patients should have had prior to surgery, will frequently require a repeat of the sessions previously ordered. The implementation of a gentle aerobic reconditioning program (e.g., walking) and back education within the first post-operative week is appropriate in uncomplicated post-surgical cases. Some patients may benefit from several occupational therapy visits to improve performance of ADLs. Participation in an active therapy program which includes restoration of ROM, core stabilization, strengthening, and endurance is recommended to be initiated 3-6 weeks post-operatively. The goals of the therapy program should include instruction in a long-term home based exercise program. (Refer to Active Therapy.)

### 4. Laminotomy/Laminectomy/Foramenotomy/Facetectomy for Central or Lateral Spinal Stenosis

a. Description - these procedures provide access to produce neural decompression by partial or total removal of various parts of spinous elements.

b. Complications—appropriate medical disclosures should be provided to the patient as deemed necessary by the treating physician.

c. Surgical indications include all of the following: radicular symptoms or symptoms of neurogenic claudication on exam, and failure of non-surgical care.

i. The non-operative improvement appears to be less likely for stenosis than for herniated discs.

d. Operative Treatment—laminotomy, laminectomy root decompression, and excision of synovial cyst.

e. Post-Operative Therapy—a formal physical therapy program should be implemented post-operatively. Active treatment, which patients should have had prior to surgery, will frequently require a repeat of the sessions previously ordered. The implementation of a gentle aerobic reconditioning program (e.g., walking) and back education within the first post-operative week is appropriate in uncomplicated post-surgical cases. Some patients may benefit from several occupational therapy visits to improve performance of ADLs. Participation in an active therapy program which includes restoration of ROM, core stabilization, strengthening, and endurance is recommended to be initiated three to six weeks post-operatively. The goals of the therapy program should include instruction in a long-term home based exercise program. (Refer to Therapy-Active).

### 5. Spinal Fusion

a. Description. Use of bone grafts, sometimes combined with metal devices, to produce a rigid connection between two or more adjacent vertebrae.

b. Complications. Appropriate medical disclosures should be provided to the patient as deemed necessary by the treating physician.



c. **Surgical Indications.** A timely decision-making process is recommended when considering patients for possible fusion. For chronic low back problems, fusion should not be considered within the first five months of symptoms, except for fracture or dislocation.

i. Although there is a statistical correlation between successful radiographic fusion and a good functional outcome, the relationship is not strong in the first two years. However, a recent observational study appears to indicate clinical deterioration in patients with unsuccessful radiographic fusion at an average of seven years post-operatively. There is good evidence that instrumented fusion, compared to non-instrumented fusion, produces a slightly better radiographically-confirmed bony union, with small to moderate functional advantages. Studies of surgical procedures report higher rates of complications with instrumented fusion.

ii. There is good evidence that intensive exercise for approximately 25 hours per week for four weeks combined with cognitive interventions emphasizing the benefits of maintaining usual activity, produces functional results similar to those of posterolateral fusion after one year. There is some evidence that lumbar fusion produces better symptomatic and functional results in patients with chronic non-radicular pain when several months of conservative treatment have not produced a satisfactory outcome. Fusions associated with decompression are more likely to reduce leg pain.

iii. Recombinant human bone morphogenetic protein (rhBMP-2) is a member of a family of cytokines capable of inducing bone formation. It is produced from genetically modified cell lines using molecular cloning techniques. At the time of this guideline writing, rhBMP-2 is FDA approved for use in anterior lumbar interbody fusion (ALIF) and is used with a carrier such as a collagen sponge or other matrix, and a cage. There is some evidence that anterior interbody cage fusion using rhBMP-2 results in shorter operative time compared with the use of iliac crest bone autograft. Minor pain at the iliac crest donor site may persist for 24 months or longer in approximately 30 percent of patients who undergo an autograft procedure. RhBMP-2 avoids the need for harvesting iliac crest donor bone and can therefore, avoid this complication of persistent pain. There is a potential for patients to develop sensitizing or blocking antibodies to rhBMP-2 or to the absorbable collagen sponge. The long-term effects are unknown. The rhBMP-2 used with the interbody fusion device is contraindicated for patients with a known hypersensitivity to Recombinant Human Bone Morphogenetic Protein -2, bovine type 1 collagen, or to other components of the formulation. Use of rhBMP-2 outside the anterior cage may carry a risk of swelling and ectopic bone formation which can encroach on neurovascular structures. At the time of this guideline writing, it is still investigational. Information concerning safe and effective dosing and application are being submitted to the FDA. All other applications are considered off-label and not FDA approved. There is insufficient information to form a recommendation with instrumentation other than the

cage specifically designed for anterior procedures. If the FDA approves its use for other operative approaches, prior authorization is required. The patient must meet all indications on the device manufacturer's list and have no contraindications. The formation of exuberant or ectopic bone growth at the upper levels (L2-L4) may have a deleterious impact on certain neurovascular structures, such as the aorta and sympathetic nerve chain. There are also reports of osteoclastic activity with the use of rhBMP-2.

d. Indications for spinal fusion may include:

i. neural arch defect—spondylolytic spondylolisthesis, congenital unilateral neural arch hypoplasia;

ii. segmental instability—excessive motion, as in degenerative spondylolisthesis, surgically induced segmental instability;

iii. primary mechanical back pain/functional spinal unit failure—multiple pain generators objectively involving two or more of the following:

(a). internal disc disruption (poor success rate if more than one disc involved);

(b). painful motion segment, as in annular tears;

(c). disc resorption;

(d). facet syndrome; and/or

(e). ligamentous tear;

iv. revision surgery for failed previous operation(s) if significant functional gains are anticipated;

v. infection, tumor, or deformity of the lumbosacral spine that cause intractable pain, neurological deficit, and/or functional disability.

e. **Pre-operative Surgical Indications:** Required pre-operative clinical surgical indications for spinal fusion include all of the following:

i. all pain generators are adequately defined and treated; and

ii. all physical medicine and manual therapy interventions are completed; and

iii. x-ray, MRI, or CT/Discography demonstrate disc pathology or spinal instability; and

iv. spine pathology is limited to two levels; and

v. psychosocial evaluation with confounding issues addressed;

vi. for any potential fusion surgery, it is recommended that the injured worker refrain from smoking for at least six weeks prior to surgery and during the period of fusion healing. Because smokers have a higher risk of non-union and higher post-operative costs, it is recommended that insurers cover a smoking cessation program peri-operatively.

f. Operative Therapy. Operative procedures may include:

- i. intertransverse fusion;
- ii. anterior fusion (with or without rhBMP-2)—generally used for component of discogenic pain where there is no significant radicular component requiring decompression;
- iii. posterior interbody fusion—generally used for component of discogenic pain where posterior decompression for radicular symptoms also performed; or
- iv. anterior/posterior (360°) Fusion—most commonly seen in unstable or potentially unstable situations or non-union of a previous fusion.

g. Post-Operative Therapy. A formal physical therapy program should be implemented post-operatively. Active treatment, which patients should have had prior to surgery, will frequently require a repeat of the sessions previously ordered. The implementation of a gentle aerobic reconditioning program (e.g., walking), and back education within the first post-operative week is appropriate in uncomplicated post-surgical cases. Some patients may benefit from several occupational therapy visits to improve performance of ADLs. Participation in an active therapy program which includes core stabilization, strengthening, and endurance is recommended to be initiated once the fusion is solid and without complication. The goals of the therapy program should include instruction in a long-term home based exercise program. (Refer to Active Therapy).

h. Return-to-Work. Barring complications, patients responding favorably to spinal fusion may be able to return to sedentary-to-light work within 6 to 12 weeks post-operatively, light-to-medium work within six to nine months post-operatively and medium-to-medium/heavy work within 6 to 12 months post-operatively. Patients requiring fusion whose previous occupation involved heavy-to-very-heavy labor should be considered for vocational assessment as soon as reasonable restrictions can be predicted. The practitioner should release the patient with specific physical restrictions and should obtain a clear job description from the employer, if necessary. Once an injured worker is off work greater than six months, the functional prognosis with or without fusion becomes guarded for that individual.

## 6. Sacroiliac Joint Fusion

a. Description. Use of bone grafts, sometimes combined with metal devices, to produce a rigid connection between two or more adjacent vertebrae providing symptomatic instability as a part of major pelvic ring disruption.

i. Identifying the SI joint as the pain generator is challenging due to the multifactorial nature of low back pain. Once confirmed, management may include physical or manual therapy with a focus on core and pelvic stability, external orthotics, periodic intra-articular injections, anti-inflammatory medications, and life style changes including smoking cessation and weight loss.

b. Complications. Instrumentation failure, bone graft donor site pain, in-hospital mortality, deep infection, superficial infection, and graft extrusion.

### c. General Requirements

i. Conservative management should include all of the following:

- (a). activity modification;
- (b). active therapeutic exercise program, physical therapy, or manual therapy;
- (c). anti-inflammatory medications and analgesics; and
- (d). corticosteroid injection.

ii. Tobacco cessation. a tobacco-cessation program resulting in abstinence from tobacco for at least six weeks prior to surgery is recommended.

iii. Body Mass Index (BMI). Patient with a BMI equal to or greater than 40 should attempt weight loss prior to surgery.

### d. Indications and Criteria

i. Percutaneous/Minimally Invasive SI Joint Fusion may be considered medically necessary when all of the following criteria are met:

(a). persistent pain with a VAS of 5 or greater for more than six months' duration that interferes with functional activities;

(b). failure of conservative management for at least six months;

(c). confirmation of the SI joint as a pain generator as demonstrated by all of the following:

- (i). pain pattern consistent with SI joint pain;
- (ii). positive finger Fortin test (tenderness over the sacral sulcus);

(iii).lack of tenderness elsewhere in the pelvic region;

(iv).positive result from at least three provocative tests:

[a].long ligament test;

[b].Faber's test/Patrick's sign;

[c].active straight leg raise;

[d].compression test;

[e].distraction test;

[f].thigh thrust test; or

[g].Gaenslen's test;

(v). and other sources of pain have been excluded as a cause;

(d). diagnostic studies that include all of the following:

(i). imaging (plain radiographs and a CT) or MRI of the SI joint;

(ii). AP plain radiograph of the pelvis to exclude hip pathology;

(iii). CT or MRI of the lumbar spine to rule out neural compression or other degenerative condition;

(iv). imaging of SI joint that indicates evidence of injury and/or degeneration;

(e). and confirmation of the SI joint as the pain generator. This can be demonstrated by at least 50 percent reduction of pain for the expected duration of the anesthetic utilized following an intra-articular SI joint injection. This must be done on two separate occasions.

e. Exclusions

i. Indications other than those addresses in this section are considered not medically necessary, including but not limited to the following:

(a). presence of infection, tumor, or fracture;

(b). acute, traumatic instability of the SI joint;

(c). presence of compression that correlates with symptoms or other more likely source of pain;

(d). generalized pain behavior such as somatoform disorder or generalized pain disorders like fibromyalgia; or

(e). ankylosing spondylitis or rheumatoid arthritis.

7. Implantable spinal cord stimulators are reserved for those low back pain patients with pain of greater than six months duration who have not responded to the standard non-operative or operative interventions previously discussed within this document. Refer to OWCA's Chronic Pain Disorder Medical Treatment Guidelines.

8. Laser discectomy involves the delivery of laser energy into the center of the nucleus pulposus using a fluoroscopically guided laser fiber under local anesthesia. The energy denatures protein in the nucleus, causing a structural change which is intended to reduce intradiscal pressure. Its effectiveness has not been shown. Laser discectomy is not recommended.

9. Artificial Lumbar Disc Replacement

a. Description. This involves the insertion of a prosthetic device into an intervertebral space from which a degenerated disc has been removed, sparing only the peripheral annulus. The endplates are positioned under intraoperative fluoroscopic guidance for optimal placement in the sagittal and frontal planes. The prosthetic device is designed to distribute the mechanical load of the vertebrae in a physiologic manner and maintain range of motion.

i. General selection criteria for lumbar disc replacement includes symptomatic one-level degenerative disc disease. The patient must also meet fusion surgery criteria, and if the patient is not a candidate for fusion, a disc replacement procedure should not be considered. Additionally, the patient should be able to comply with pre- and post-surgery protocol.

ii. The theoretical advantage of total disc arthroplasty is that it preserves range of motion and physiologic loading of the disc. This could be an advantage for adults who are physically active. Studies do not demonstrate a long-term advantage of measured function or pain over comparison groups undergoing fusion. The longevity of this prosthetic device has not yet been determined. Significant technical training and experience is required to perform this procedure successfully. Surgeons must be well-versed in anterior spinal techniques and should have attended appropriate training courses, or have undergone training during a fellowship. Mentoring and proctoring of procedures is highly recommended. Reasonable pre-operative evaluation may include an angiogram to identify great vessel location. The angiogram may be either with contrast or with magnetic resonance imaging. An assistant surgeon with anterior access experience is required.

b. Complications:

i. nerve and vascular injury;

ii. dural tears;

iii. sexual dysfunction (retrograde ejaculation);

iv. mal-positioning of the prosthesis;

v. suboptimal positioning of the prosthetic may compromise the long-term clinical result;

vi. Complex Regional Pain Syndrome (CRPS);

vii. complications from Abdominal Surgery, (e.g., hernia or adhesions);

viii. re-operation due to complications;

ix. appropriate medical disclosures should be provided to the patient as deemed necessary by the treating physician.

c. Surgical Indications:

i. symptomatic one-level degenerative disc disease established by objective testing (CT or MRI scan followed by positive provocation discogram);

ii. symptoms unrelieved after six months of active non-surgical treatment;

iii. all pain generators are adequately defined and treated;

iv. all physical medicine and manual therapy interventions are completed;

v. spine pathology limited to one level;

vi. psychosocial evaluation with confounding issues addressed.

d. Contraindications:

- i. significant spinal deformity/scoliosis;
- ii. facet joint arthrosis;
- iii. spinal instability;
- iv. deficient posterior elements;
- v. infection;
- vi. any contraindications to an anterior abdominal approach (including multiple prior abdominal procedures);
- vii. evidence of nerve root compression, depending on the device used;
- viii. previous compression or burst fracture ;
- ix. multiple-level degenerative disc disease (DDD);
- x. spondylolysis;
- xi. spondylolisthesis greater than 3 mm;
- xii. osteoporosis or any metabolic bone disease;
- xiii. chronic steroid use or use of other medication known to interfere with bone or soft tissue healing;
- xiv. autoimmune disorder;
- xv. allergy to device components/materials;
- xvi. depending on the device selected, pregnancy or desire to become pregnant;
- xvii. morbid obesity (e.g., body/mass index [BMI] of greater than 40, over 100 pounds overweight);
- xviii. active malignancy.

e. Post-Operative Therapy. Bracing may be appropriate. A formal physical therapy program should be implemented post-operatively. Active treatment, which patients should have had prior to surgery, will frequently require a repeat of the sessions previously ordered. The implementation of a gentle aerobic reconditioning program (e.g., walking) and back education within the first post-operative week is appropriate in uncomplicated post-surgical cases. Some patients may benefit from several occupational therapy visits to improve performance of ADLs. Participation in an active therapy program which includes restoration of ROM, core stabilization, strengthening, and endurance is recommended to be initiated at the discretion of the surgeon. Lifting and bending are usually limited for several months at least. Sedentary duty may be able to begin within six weeks in uncomplicated cases. The goals of the therapy program should include instruction in a long-term home based exercise program. (Refer to Active Therapy.)

10. Kyphoplasty

a. Description. A surgical procedure for the treatment of symptomatic thoracic or lumbar vertebral

compression fractures, most commonly due to osteoporosis or other metabolic bone disease, and occasionally with post-traumatic compression fractures and minor burst fractures that do not significantly compromise the posterior cortex of the vertebral body. Pain relief can be expected in approximately 90 percent of patients. Vertebral height correction is inconsistent, with approximately 35 percent to 40 percent of procedures failing to restore height or kyphotic angle.

b. Complications. Cement leakage occurs in approximately nine percent of kyphoplasties and may cause complications. New vertebral compression fracture may occur following kyphoplasty, but their occurrence does not appear to exceed that of osteoporotic patients who did not receive treatment.

c. Operative Treatment. Kyphoplasty involves the percutaneous insertion of a trocar and inflatable balloon or expanding polymer into the vertebral body, which re-expands the body, elevating the endplates and reducing the compression deformity. Polymethylmethacrylate (PMMA) bone cement is injected under low pressure into the cavity created by the balloon inflation. In contrast to vertebroplasty, which introduces PMMA cement under high pressure, the space created by balloon inflation allows a higher viscosity PMMA to be injected under lower pressure, which may reduce the risks associated with extravertebral extravasation of the material. There may be an advantage to performing the procedure within one month of the fracture, since the elevation of the endplates may be more readily achieved than when the procedure is delayed.

d. Surgical Indications. Kyphoplasty is an accepted treatment for the following indications:

- i. compression fracture;
- ii. vertebral height loss between 20 percent and 85 percent;
- iii. vertebral height restoration. Kyphoplasty is more likely to increase vertebral height if performed within 30 days of fracture occurrence.

e. Contraindications:

- i. the presence of neurologic compromise related to fracture;
- ii. high-velocity fractures with a significant burst component;
- iii. significant posterior vertebral body wall fracture;
- iv. severe vertebral collapse (vertebra plana);
- v. infection, and
- vi. coagulopathy.

11. Vertebroplasty

a. Description vertebroplasty is a procedure for the treatment of painful thoracic and lumbar vertebral compression fractures caused by osteoporosis or other

metabolic bone disease. Polymethylmethacrylate (PMMA) bone cement is injected with high pressure into the vertebral body via an 11- to 13-gauge needle, with the goal of stabilizing the spine and relieving pain. The procedure does not correct spinal deformity. Pain relief can be expected in approximately 90 percent of patients. Vertebral height correction is inconsistent, with approximately 35 percent to 40 percent of procedures failing to restore height or kyphotic angle.

b. Complications

i. Because the bone cement is of low viscosity, its injection under pressure frequently results in extravertebral extravasation of the material, with rare serious complications such as pulmonary embolism. Cement leakage alone occurs in approximately 40 percent of vertebroplasties.

ii. New vertebral compression fractures may occur following vertebroplasty, but their occurrence does not appear to exceed that of osteoporotic patients who did not receive treatment.

c. Indications:

i. compression fracture of preferably less than 30 days;

ii. vertebral height loss between 20 percent and 85 percent;

iii. intact posterior wall.

d. Contraindications:

i. the presence of neurologic compromise related to the fracture;

ii. high velocity fractures with a significant burst component;

iii. posterior vertebral body wall fracture;

iv. severe vertebral collapse (vertebra plana); and

v. infection; and

vi. coagulopathy.

12. Percutaneous radiofrequency disc decompression is an investigational procedure which introduces a 17 gauge cannula under local anesthesia and fluoroscopic guidance into the nucleus pulposus of the contained herniated disc, using radiofrequency energy to dissolve and remove disc material. Pressure inside the disc is lowered as a result. There have been no randomized clinical trials of this procedure at this time. Percutaneous radiofrequency disc decompression is not recommended.

13. Nucleus pulposus replacement involves the introduction of a prosthetic implant into the intervertebral disc, replacing the nucleus while preserving the annulus fibrosus. It is limited to investigational use in the United States at this time. It is not recommended.

14. Epiduroscopy and Epidural Lysis of Adhesions (Refer to Injections-Therapeutic).

15. Intraoperative neurophysiologic monitoring (IONM) is a battery of neurophysiologic tests used to assess the functional integrity of the spinal cord, nerve roots, and other peripheral nervous system structures (eg, brachial plexus) during spinal surgery. The underlying principle of IONM is to identify emerging insult to nervous system structures, pathways, and/or related vascular supply and to provide feedback regarding correlative changes in neural function before development of irreversible neural injury. IONM data provide an opportunity for intervention to prevent or minimize postoperative neurologic deficit. Current multimodality monitoring techniques permit intraoperative assessment of the functional integrity of afferent dorsal sensory spinal cord tracts, efferent ventral spinal cord tracts, and nerve roots. Combined use of these techniques is useful during complex spinal surgery because these monitoring modalities provide important complementary information to the surgery team. Intraoperative neurophysiologic monitoring should be used during spinal surgery when information regarding spinal cord and nerve root function is desired. The appropriate diagnostic modality for the proposed surgical intervention should be utilized at the discretion of the surgeon.

16. Non-invasive electrical bone growth stimulators may be considered:

a. as an adjunct to spinal fusion surgery for those at high risk for pseudoarthrosis, including one or more of the following fusion failure risk factors:

i. one or more previous failed spinal fusion(s);

ii. grade II or worse spondylolisthesis;

iii. fusion to be performed at more than one level;

iv. presence of other risk factors that may contribute to non-healing:

(a). current smoking;

(b). diabetes;

(c). renal disease;

(d). other metabolic diseases where bone healing is likely to be compromised (e.g.: significant osteoporosis);

(e). active alcoholism;

(f). morbid obesity BMI >40;

b. as treatment for individuals with failed spinal fusion. Failed spinal fusion is defined as a spinal fusion that has not healed at a minimum of six months after the original surgery, as evidenced by serial x-rays over a course of three months during the latter portion of the six-month period;

c. no strict criteria for device removal are suggested in the literature. Implanted devices are generally removed only when the patient complains of discomfort, when there is device malfunction, or to allow for future ability to use MRI. Removal of batteries is not recommended unless there is a device malfunction or other complication

**AUTHORITY NOTE:** Promulgated in accordance with R.S. 23:1203.1.

**HISTORICAL NOTE:** Promulgated by the Louisiana Workforce Commission, Office of Workers Compensation Administration, LR 37:1676 (June 2011), amended by the Louisiana Workforce Commission, Office of Workers Compensation, LR 40:1151 (June 2014), LR 46:1256 (September 2020).

## **Chapter 21. Pain Medical Treatment Guidelines**

### **Subchapter A. Chronic Pain Disorder Medical Treatment Guidelines**

Editor's Note: Form LWC-WC 1009. Disputed Claim for Medical Treatment has been moved to §2328 of this Part.

#### **§2101. Introduction**

A. This document has been prepared by the Louisiana Workforce Commission, Office of Workers' Compensation (OWCA) and should be interpreted within the context of guidelines for physicians/providers treating individuals qualifying under Louisiana Workers' Compensation Act as injured workers with chronic pain. Although the primary purpose of this document is advisory and educational, the guidelines are enforceable under the Louisiana Workers Compensation Act. All medical care, services, and treatment owed by the employer to the employee in accordance with the Louisiana Workers' Compensation Act shall mean care, services, and treatment in accordance with these guidelines. Medical care, services, and treatment that varies from these guidelines shall also be due by the employer when it is demonstrated to the medical director of the office by a preponderance of the scientific medical evidence, that a variance from these guidelines is reasonably required to cure or relieve the injured worker from the effects of the injury or occupational disease given the circumstances. Therefore, these guidelines are not relevant as evidence of a provider's legal standard of professional care. To properly utilize this document, the reader should not skip nor overlook any sections.

**AUTHORITY NOTE:** Promulgated in accordance with R.S. 23:1203.1.

**HISTORICAL NOTE:** Promulgated by the Louisiana Workforce Commission, Office of Workers Compensation Administration, LR 37:1681 (June 2011), amended LR 46:194 (February 2020).

#### **§2103. General Guideline Principles**

A. The principles summarized in this Section are key to the intended implementation of all Office of Workers' Compensation medical treatment guidelines and critical to the reader's application of the guidelines in this document.

1. **Application of Guidelines.** The OWCA provides procedures to implement medical treatment guidelines and to foster communication to resolve disputes among the provider, payer, and patient through the Workers Compensation Act.

2. **Education.** Education of the patient and family, as well as the employer, insurer, policy makers and the

community should be the primary emphasis in the treatment of chronic pain and disability. Currently, practitioners often think of education last, after medications, manual therapy, and surgery. Practitioners must implement strategies to educate patients, employers, insurance systems, policy makers, and the community as a whole. An education-based paradigm should always start with inexpensive communication providing reassuring and evidence-based information to the patient. More in-depth education is currently a component of treatment regimens which employ functional, restorative, preventive and rehabilitative programs. No treatment plan is complete without addressing issues of individual and/or group patient education as a means of facilitating self-management of symptoms and prevention. Facilitation through language interpretation, when necessary, is a priority and part of the medical care treatment protocol.

3. **Informed Decision Making.** Providers should implement informed decision making as a crucial element of a successful treatment plan. Patients, with the assistance of their health care practitioner, should identify their personal and professional functional goals of treatment at the first visit when a chronic pain condition allows functional improvement. Progress towards the individual's identified functional goals should be addressed by all members of the health care team at subsequent visits and throughout the established treatment plan when a chronic pain condition allows attainment of functional goals. Injured workers may not reach functional goals to return to work and therefore they will require a significantly different plan. Nurse case managers, physical therapists, and other members of the health care team play an integral role in informed decision-making and achievement of functional goals. Patient education and informed decision-making should facilitate self-management of symptoms and prevention of further injury.

4. **Treatment Parameter Duration.** Time frames for specific interventions commence once treatments have been initiated, not on the date of injury. Obviously, duration will be impacted by patient adherence, as well as availability of services. Clinical judgment may substantiate the need to accelerate or decelerate the time frames discussed in this document. Such deviation shall be in accordance with R.S. 23:1203.1.

5. **Active Interventions.** Active interventions emphasizing patient responsibility, such as therapeutic exercise and/or functional treatment, are generally emphasized over passive modalities, especially as treatment progresses. Generally, passive interventions are viewed as a means to facilitate progress in an active rehabilitation program with concomitant attainment of objective functional gains when chronic pain conditions allow attainment of functional goals because some chronic pain patients require active interventions as well maintenance procedures and medications.

6. **Active Therapeutic Exercise Program.** Exercise program goals should incorporate patient strength, endurance, flexibility, coordination, and education. This

includes functional application in vocational or community settings.

7. Positive Patient Response. Positive results are defined primarily as functional gains that can be objectively measured.

a. Objective functional gains include, but are not limited to, positional tolerances, range-of-motion (ROM), strength, endurance, activities of daily living, ability to function at work, cognition, psychological behavior, and efficiency/velocity measures that can be quantified. Not all chronic pain patients will reach any functional goals and may only improve ADL's and or pain complaints due to severity of the injury. Subjective reports of pain and function should be considered and given relative weight when the pain has anatomic and physiologic correlation. Anatomic correlation must be based on objective findings.

8. Re-Evaluation of Treatment Every Three to Four Weeks. If a given treatment or modality is not producing positive results within three to four weeks or within the time to produce effect in the non-chronic pain guidelines, the physical therapist must consult with the treating physician for consideration for a referral to a pain specialist or surgeon or other appropriate specialist for other treatment options. Reconsideration of diagnosis should also occur in the event of poor response to a seemingly rational intervention.

9. Surgical Interventions. Surgery should be contemplated within the context of expected functional outcome and not purely for the purpose of pain relief. The concept of "cure" with respect to surgical treatment by itself is generally a misnomer. All operative interventions must be based upon positive correlation of clinical findings, clinical course, and diagnostic tests. A comprehensive assimilation of these factors must lead to a specific diagnosis with positive identification of pathologic conditions.

10. Pharmacy-Louisiana Law and Regulation. All prescribing will be done in accordance with the laws of the state of Louisiana as they pertain respectively to each individual licensee, including, but not limited to: Louisiana State Board of Medical Examiners regulations governing medications used in the treatment of non-cancer-related chronic or intractable pain; Louisiana Board of Pharmacy Prescription Monitoring Program; Louisiana Department of Health and Hospitals licensing and certification standards for pain management clinics; other laws and regulations affecting the prescribing and dispensing of medications in the state of Louisiana.

11. Six Month-Time Frame. Injuries resulting in temporary total disability require maintenance treatment and may not attain return to work in six months.

12. Return to Work. Return-to-work is therapeutic, assuming the work is not likely to aggravate the basic problem or increase long-term pain. An injured worker's return-to-work status shall not be the sole cause to deny reasonable and medically necessary treatment under these guidelines. Two good practices are: early contact with injured workers and provide modified work positions for

short-term injuries. The practitioner may provide specific physical limitations and the patient should never be released to non-specific and vague descriptions such as "sedentary" or "light duty." The following physical limitations should be considered and modified as recommended: lifting, pushing, pulling, crouching, walking, using stairs, bending at the waist, awkward and/or sustained postures, tolerance for sitting or standing, hot and cold environments, data entry and other repetitive motion tasks, sustained grip, tool usage and vibration factors. Even if there is residual chronic pain, return-to-work is not necessarily contraindicated. The practitioner should understand all of the physical demands of the patient's job position before returning the patient to full duty and should request clarification of the patient's job duties. Clarification should be obtained from the employer or, if necessary, from including, but not limited to, occupational health nurse, physical therapist, occupational therapist, vocational rehabilitation specialist, or an industrial hygienist, chiropractor or another professional. American Medical Association clarifies "disability" as "activity limitations and/or participation restrictions in an individual with a health condition, disorder or disease" versus "impairment" as "a significant deviation, loss, or loss of use of any body structure or body function in an individual with a health condition, disorder or disease".

13. Delayed Recovery. Within the discretion of the treating physician, strongly consider a psychological evaluation, if not previously provided, as well as initiating interdisciplinary rehabilitation treatment and vocational goal setting, for those patients who are failing to make expected progress 6 to 12 weeks after initiation of treatment of an injury. The OWCA recognizes that 3 to 10 percent of all industrially injured patients will not recover within the timelines outlined in this document despite optimal care. Such individuals may require treatments beyond the limits discussed within this document, but such treatment requires clear documentation by the authorized treating practitioner focusing on objective functional gains afforded by further treatment and impact upon prognosis.

14. Guideline Recommendations and Inclusion of Medical Evidence. All recommendations are based on available evidence and/or consensus judgment. It is generally recognized that early reports of a positive treatment effect are frequently weakened or overturned by subsequent research. Per R.S. 1203.1, when interpreting medical evidence statements in the guideline, the following apply to the strength of recommendation.

Strong	Level 1 Evidence	We Recommend
Moderate	Level 2 and Level 3 Evidence	We Suggest
Weak	Level 4 Evidence	Treatment is an Option
Inconclusive	Evidence is Either Insufficient or Conflicting	

a. Consensus guidelines are generated by a professional organization that the guidelines are intended to serve. A committee of specialists and experts are selected by the organization to create an unbiased, vetted recommendation for the treatment of specific issues within the realm of their expertise. All recommendations in the

guideline are considered to represent reasonable care in appropriately selected cases, regardless of the level of evidence or consensus statement attached to it. Those procedures considered inappropriate, unreasonable, or unnecessary are designated in the guideline as “not recommended.”

15. Treatment of Pre-Existing Conditions. The conditions that preexisted the work injury/disease will need to be managed under two circumstances: (a) A pre-existing condition exacerbated by a work injury/disease should be treated until the patient has returned to their objectively verified prior level of functioning or Maximum Medical Improvement (MMI); and (b) A pre-existing condition not directly caused by a work injury/disease but which may prevent recovery from that injury should be treated until its objectively verified negative impact has been controlled. The focus of treatment should remain on the work injury/disease.

B. The remainder of this document should be interpreted within the parameters of these guideline principles that may lead to more optimal medical and functional outcomes for injured workers.

AUTHORITY NOTE: Promulgated in accordance with R.S. 23:1203.1.

HISTORICAL NOTE: Promulgated by the Louisiana Workforce Commission, Office of Workers Compensation Administration, LR 37:1682 (June 2011), amended by the Louisiana Workforce Commission, Office of Workers Compensation, LR 40:1155 (June 2014), amended LR 46:194 (February 2020).

#### **§2104. Overview of Chronic Pain Management**

A. It is estimated by the Institute of Medicine that approximately 100 million adults suffer from chronic pain in the United States. The World Health Organization’s survey found that 37 percent of adults in 10 developed countries have chronic pain conditions. This overview covers the biopsychosocial nature of chronic pain and a comprehensive plan of care including: functional assessment and goal setting, psychological assessment, medication management, sleep considerations, and active therapy assisted by international pain management procedures with continued therapy afterwards as well as indicated surgery.

B. Chronic pain may develop from persistent acute pain due to neuroplastic changes occurring in the central nervous system. All chronic pain appears to involve a central sensitization which changes the perception of pain. Thus, treatment patterns are aimed at a number of mechanisms contributing to chronic pain.

C. Chronic pain is recognized as a biopsychosocial disease process. Each treatment plan should be individualized with a patient-centered approach addressing the many available treatment combinations. Therefore, all areas of the chronic pain guideline should be considered when developing a treatment plan. This includes: the mandatory psychological evaluation; an active therapy plan; medications specific to the pain process for that patient; continuing functional assessment; complementary

medication alternatives, when appropriate; and continued return to work/regular daily activity.

D. Once a patient has been identified as a chronic pain patient, usually three months after an injury when pain persists or when pain persists beyond a reasonable post-operative period, the physician should perform a complete re-evaluation or may refer the patient to a pain specialist or surgeon for consultation. This will assist both the patient and the provider in developing an appropriate treatment plan. Although it is unusual to identify an unknown pathology at this point in the treatment, it is recommended that the provider acknowledge the full complement of patient symptoms and concerns. Repeating or ordering new imaging may be necessary.

E. It is essential that the patient and provider understand the type of pain the patient is experiencing and how the pain affects day-to-day activities. Identifying the presence of neuropathic pain, as well as any sources of nociceptive pain, will assist the patient and provider when choosing medication and other forms of treatment recommended in the guideline.

F. During the chronic pain assessment, it is suggested that all physicians review with the patient their usual activities over several different typical 24-hour periods. This will assist both parties in understanding what functions are not able to be performed by the patient, how significantly sleep is impacted, and whether pain is affecting social and family relationships. This information is also essential for establishing agreed upon functional goals.

G. All chronic pain patients should have psychological evaluations. Patients may merely need assistance with coping mechanisms, and/or anxiety or depression may be caused or exacerbated by chronic pain. Treatment in this area is essential for the chronic pain patient. Cognitive behavioral sessions are frequently effective for these conditions.

H. Review of the current prescribed and over-the-counter medications is an important part of this initial chronic pain evaluation. If the patient has been chronically on opioids, a pain specialist referral should be considered to identify the necessity of the opioids and the proper dose. It is also reasonable to taper opioids in order to determine the patient’s baseline and how other medications are actually affecting the pain.

1. The following is a general summary of the required elements. A number of other guidelines, including the Centers for Disease Control and Prevention (CDC) for Primary Care Practitioners and Board of Medical Examiners, have confirmed these steps.

a. An opioid trial shall be performed before chronic opioids are determined to be useful for patients. About 50 percent of patients will not be able to tolerate the side effects and/or not show a sufficient increase in function with opioid use. Patients should be aware that this is a trial and like any other medication trial, it will not be continued unless there is sufficient benefit. The average benefit is about a 30 percent



decrease in pain. Thus, all other required treatment must be continued during the time period of the chronic opioid trial.

b. Long acting opioids should never be used for acute pain, post-operative pain, or before an opioid trial has been completed. There is no evidence they are more beneficial than short acting opioids, and the trial should begin with short acting opioids.

c. A risk assessment tool, such as the Opioid Risk Tool (ORT) or Screener and Opioid Assessment for Patients with Pain (SOAPP) should be completed to assure the provider that there are no prior elements suggesting substance abuse or, when such elements are present, the physician may choose to refer to a provider with more expertise in substance abuse.

d. Urine drug testing should be done prior to initiating controlled substance.

e. Check the Prescription Monitoring Program (PMP). Follow Louisiana Revised Statutes 40:973, 40:978 and 40:978.3.

f. The psychological evaluation should have been completed and hopefully treatment as appropriate is being continued.

g. A functional history should be taken and functional goals should be set. This needs to be followed throughout all chronic pain treatment to determine if the patient is increasing or decreasing in function.

h. A provider physician agreement must be completed. This is extremely helpful as it reviews for the patient the expectations regarding his/her behavior as well as the expectations regarding when a physician would choose to taper or remove the patient from opioids and what other treatment is expected to continue during an opioid trial.

2. If the opioid trial is successful, the physician should continue to monitor with random drug testing and PMP checks. "Random drug testing" should be four times a year or possibly more with documented suspicion of abuse or diversion. Quantitative testing is appropriate in cases of inconsistent findings, suspicions, or for particular medications that patient is utilizing that is not in the qualitative testing. In addition, the Current Opioid Misuse Measure (COMM) is an example of a tool that can be used for patients on opioids to screen for possible abuse. It should be noted that current estimates suggest approximately 14 to 19 percent of chronic opioid users may become addicted to opioids.

I. The patient will need to be monitored for side effects. Constipation is anticipated. There may also be problems with sexual dysfunction. Opioids may increase or cause sleep apnea problems, and this should be monitored. At all visits, the functional status of the patient should be recorded. This can be accomplished with reliable, patient-reported functional status tools. Function is preferably validated by physical exam or by other objective measures from the provider.

J. Lack of sleep is a significant problem for patients with uncontrolled chronic pain. Taking a good history in this area and promoting an appropriate sleep regime is essential for patients, if they are to establish a productive life-style.

K. Active therapy is one of the most important components. Regular exercise is shown to decrease depression as well as decrease chronic pain. Helping the patient choose appropriate physical activities and cognitive activities will be important for recovery. Physician directed exercise, home stretching exercise, does not have to be formal course of physical therapy (as long as the patient has previously undergone a formal course of physical therapy).

L. Although treating chronic pain patients is challenging due to the many disciplines and treatment patterns available, the rewards are great when a patient with chronic pain is able to resume work and engage in satisfying life activities.

AUTHORITY NOTE: Promulgated in accordance with R.S. 23:1203.1.

HISTORICAL NOTE: Promulgated by the Louisiana Workforce Commission, Office of Workers Compensation Administration, LR 46:196 (February 2020).

### **§2105. Introduction to Chronic Pain**

A. The International Association for the Study of Pain (IASP) defines pain as "an unpleasant sensory and emotional experience with actual or potential tissue damage." Pain is a complex experience embracing physical, mental, social, and behavioral processes that often compromises the quality of life of many individuals. Pain is an unpleasant subjective perception usually in the context of tissue damage.

B. Pain is subjective and cannot be measured or indicated objectively. Pain evokes negative emotional reactions such as fear, anxiety, anger, and depression. People usually regard pain as an indicator of physical harm, despite the fact that pain can exist without tissue damage and tissue damage can exist without pain. Many people report pain in the absence of tissue damage or any likely pathophysiologic cause. There is no way to distinguish their experience from that due to actual tissue damage. If they regard their experience as pain and they report it the same way as pain caused by tissue damage, it should be accepted as pain.

C. Pain can generally be classified as:

1. Nociceptive which includes pain from visceral origins or damage to other tissues. Myofascial pain is a nociceptive type of pain characterized by myofascial trigger points limited to a specific muscle or muscles.

2. neuropathic including pain originating from brain, peripheral nerves or both; and

3. psychogenic which originates in mood, characterological, social, or psychophysiological processes.

D. Recent advances in the neurosciences reveal additional mechanisms involved in chronic pain. In the past, pain was seen as a sensation arising from the stimulation of pain receptors by damaged tissue, initiating a sequence of nerve signals ending in the brain and there recognized as pain. A consequence of this model was that ongoing pain

following resolution of tissue damage was seen as less physiological and more psychological than acute pain with identifiable tissue injury. Current research indicates that chronic pain involves additional mechanisms that cause: neural remodeling at the level of the spinal cord and higher levels of the central nervous system; changes in membrane responsiveness and connectivity leading to activation of larger pain pathways; and recruitment of distinct neurotransmitters.

E. Changes in gene function and expression may occur, with lasting functional consequences. These physiologic functional changes cause chronic pain to be experienced in body regions beyond the original injury and to be exacerbated by little or no stimulation. The chronic pain experience clearly represents both psychologic and complex physiologic mechanisms, many of which are just beginning to be understood.

F. *Chronic pain* is defined as "pain that persists for at least 30 days beyond the usual course of an acute disease or a reasonable time for an injury to heal or that is associated with a chronic pathological process that causes continuous pain (e.g., Complex Regional Pain Syndrome)." The very definition of chronic pain describes a delay or outright failure to relieve pain associated with some specific illness or accident. Delayed recovery should prompt a clinical review of the case and a psychological evaluation by the health care provider. Referral to a specialist with experience in pain management is recommended.

G. The term "chronic pain syndrome" has been incorrectly used and defined in a variety of ways that generally indicate a belief on the part of the health care provider that the patient's pain is inappropriate or out of proportion to existing problems or illness. Use of the term "chronic pain syndrome" should be discontinued because the term ceases to have meaning due to the many different physical and psychosocial issues associated with it. The IASP offers taxonomy of pain, which underscores the wide variety of pathological conditions associated with chronic pain. This classification system may not address the psychological and psychosocial issues that occur in the perception of pain, suffering, and disability and may require referral to psychiatric or psychological clinicians. Practitioners should use the nationally accepted terminology indicated in the most current ICD system. Chronic pain can be diagnosed as F45.42 "Pain disorder with related psychological factors" when the associated body part code is also provided. Alternately, chronic pain can also be diagnosed as F54 "Psychological factors affecting physical conditions," and this code should also be accompanied by the associated body part. G89.4 "chronic pain associated with significant psychosocial dysfunction" may also be utilized.

H. Injured patients generally initiate treatment with complaints of pain, which is generally attributable to a specific injurious event, but occasionally to an ostensible injury. Thus, the physician should not automatically assume that complaints of acute pain are directly attributable to pathophysiology at the tissue level. Pain is known to be

associated with sensory, affective, cognitive, social, and other processes. The pain sensory system itself is organized into two parts, often called first and second pain. A-Delta nerve fibers conduct first pain via the neospinalthalamic tract to the somatosensory cortex and provide information about pain location and quality. In contrast, unmyelinated C fibers conduct second pain via the paleospinalthalamic tract and provide information about pain intensity. Second pain is more closely associated with emotion and memory neural systems than it is with sensory systems.

I. As a patient's condition transitions through the acute, subacute, and chronic phases, the central nervous system (CNS) is reorganized. The temporal summation of second pain produces a sensitization or "windup" of the spinal cord, and the connections between the brain regions involved in pain perception, emotion, arousal, and judgment are changed by persistent pain. These changes cause the CNS's "pain neuromatrix" to become sensitized to pain. This CNS reorganization is also associated with changes in the volume of brain areas, decreased grey matter in the prefrontal cortex, and the brain appearing to age more rapidly. As pain continues over time, the CNS remodels itself so that pain becomes less closely associated with sensation, and more closely associated with arousal, emotion, memory, and beliefs. Because of these CNS processes, all clinicians should be aware that as the patient enters the subacute phase, it becomes increasingly important to consider the psychosocial context of the disorder being treated, including the patient's social circumstances, arousal level, emotional state, and beliefs about the disorder. However, behavioral complications and physiological changes associated with chronicity and central sensitization may also be present in the acute phase, and within hours of the initial injury. It is the intent of many of the treatments in this guideline to assist in remodeling these CNS changes.

J. Chronic pain is a phenomenon not specifically relegated to anatomical or physiologic parameters. The prevailing biomedical model (which focuses on identified disease pathology as the sole cause of pain) cannot capture all of the important variables in pain behavior. While diagnostic labels may pinpoint contributory physical and/or psychological factors and lead to specific treatment interventions that are helpful, a large number of patients defy precise taxonomic classification. Furthermore, such diagnostic labeling often overlooks important social contributions to the chronic pain experience. Failure to address these operational parameters of the chronic pain experience may lead to incomplete or faulty treatment plans. The concept of a "pain disorder" is perhaps the most useful term, in that it captures the multi-factorial nature of the chronic pain experience.

K. It is recognized that some health care practitioners, by virtue of their experience, additional training, and/or accreditation by pain specialty organizations, have much greater expertise in the area of chronic pain evaluation and treatment than others. Referrals for the treatment of chronic pain should be to such recognized specialists. Chronic pain treatment plans should be monitored and coordinated by

physicians with expertise in pain management including specialty training, and/or certification.

L. Most acute and some chronic pain problems are adequately addressed in other OWCA medical treatment guidelines, and are generally not within the scope of this guideline. However, because chronic pain is more often than not multi-factorial, involving more than one pathophysiologic or mental disorder, some overlap with other guidelines is inevitable. This guideline is meant to apply to any patient who fits the operational definition of chronic pain discussed at the beginning of this Section.

AUTHORITY NOTE: Promulgated in accordance with R.S. 23:1203.1.

HISTORICAL NOTE: Promulgated by the Louisiana Workforce Commission, Office of Workers Compensation Administration, LR 37:1683 (June 2011), amended LR 46:197 (February 2020).

### §2107. Definitions

A. Aftersensation refers to the abnormal persistence of a sensory perception, provoked by a stimulus even though the stimulus has ceased.

B. Allodynia is pain due to a non-noxious stimulus that does not normally provoke pain.

1. Mechanical Allodynia—refers to the abnormal perception of pain from usually non-painful mechanical stimulation.

2. Static Mechanical Allodynia—refers to pain obtained by applying a single stimulus such as light pressure to a defined area.

3. Dynamic Mechanical Allodynia—obtained by moving the stimulus such as a brush or cotton tip across the abnormal hypersensitive area.

4. Thermal Allodynia—refers to the abnormal sensation of pain from usually non-painful thermal stimulation such as cold or warmth.

C. Analgesia. Absence of pain in response to stimulation that would normally be painful.

D. Biopsychosocial. A term that reflects the multiple facets of any clinical situation; namely, the biological, psychological, and social situation of the patient.

E. Central Pain. Pain initiated or caused by a primary lesion or dysfunction in the central nervous system.

F. Central Sensitization. The experience of pain evoked by the excitation of non-nociceptive neurons or of nerve fibers that normally relay non-painful sensations to the spinal cord. This results when non-nociceptive afferent neurons act on a sensitized central nervous system (CNS). Experimental data suggest that pathways normally carrying pain signals themselves become overstimulated and/or fail to respond to inhibitory influences causing increased pain. An example is ‘wind-up’ which occurs when cells in the dorsal horn of the spinal cord increase their rate of action potential discharge in response to repeated stimulation by nociceptors.

G. Dysesthesia. An abnormal sensation described by the patient as unpleasant. As with paresthesia, dysesthesia may be spontaneous or evoked by maneuvers on physical examination.

H. Hyperalgesia. Refers to an exaggerated pain response from a usually painful stimulation.

I. Hyperesthesia (positive sensory phenomenon). Includes allodynia, hyperalgesia, and hyperpathia. Elicited by light touch, pin prick, cold, warm, vibration, joint position sensation or two-point discrimination, which is perceived as increased or more.

J. Hyperpathia. A condition of altered perception such that stimuli which would normally be innocuous, if repeated or prolonged, result in severe explosive persistent pain.

K. Hypoalgesia. Diminished pain perception in response to a normally painful stimulus.

L. Hypoesthesia/Hypesthesia (negative sensory phenomena). diminished sensitivity to stimulation.

M. Malingering. Intentional feigning of illness or disability in order to achieve external incentives such as recreational drugs or money.

N. Myofascial Pain. A regional pain characterized by tender points in taut bands of muscle that produce pain in a characteristic reference zone.

O. Myofascial Trigger Point. A physical sign in a muscle which includes, exquisite tenderness in a taut muscle band; and referred pain elicited by mechanical stimulation of the trigger point. The following findings may be associated with myofascial trigger points: Local twitch or contraction of the taut band when the trigger point is mechanically stimulated; Reproduction of the patient’s spontaneous pain pattern when the trigger point is mechanically stimulated; Weakness without muscle atrophy; and restricted range of motion of the affected muscle; and Autonomic dysfunction associated with the trigger point such as changes in skin or limb temperature.

P. Neuralgia. Pain in the distribution of a nerve or nerves.

Q. Neuritis. Inflammation of a nerve or nerves.

R. Neurogenic Pain. Pain initiated or caused by a primary lesion, dysfunction, or transitory perturbation in the peripheral or central nervous system.

S. Neuropathic Pain. Pain due to an injured or dysfunctional central or peripheral nervous system.

T. Neuropathy. A disturbance of function or pathological change in a nerve: in one nerve (mononeuropathy); in several nerves (mononeuropathy multiplex); or diffuse and bilateral (polyneuropathy). Neuropathy should be associated with objective findings such as consistent sensory abnormalities, consistent motor findings (e.g., weakness, atrophy, fasciculation’s, muscle cramping), and/or neuropathic abnormalities on EMG/nerve conduction testing.

U. **Nociceptor.** A receptor preferentially sensitive to a noxious stimulus or to a stimulus which would become noxious if prolonged.

V. **Pain Behavior.** The non-verbal actions (such as grimacing, groaning, limping, using visible pain relieving or support devices and requisition of pain medications, among others) that are outward manifestations of pain, and through which a person may communicate that pain is being experienced.

W. **Pain Threshold.** The smallest stimulus perceived by a subject as painful during laboratory testing. The term also loosely applies to the biological variation among human beings in sensing and coping with pain.

X. **Paresthesia.** An abnormal sensation that is not described as pain. It can be either a spontaneous sensation (such as pins and needles) or a sensation evoked from non-painful or painful stimulation, such as light touch, thermal, or pinprick stimulus on physical examination.

Y. **Peripheral Neuropathic Pain.** Pain initiated or caused by a primary lesion or dysfunction in the peripheral nervous system.

Z. **Somatic Dysfunction:** impaired or altered function of related components of the somatic (body framework) system which includes skeletal, arthroal, and myofascial structures.

AA. **Summation.** Refers to abnormally painful sensation to a repeated stimulus although the actual stimulus remains constant. The patient describes the pain as growing and growing as the same intensity stimulus continues.

BB. **Sympathetically Maintained Pain (smp).** A pain that is maintained by sympathetic efferent pathways and is eliminated by blockade of these pathways. It is intensified by circulating catecholamines.

CC. **Tender Points.** Tenderness on palpation at a tendon insertion, muscle belly or over bone. Palpation should be done with the thumb or forefinger, applying pressure approximately equal to a force of 4 kilograms (blanching of the entire nail bed).

**AUTHORITY NOTE:** Promulgated in accordance with R.S. 23:1203.1.

**HISTORICAL NOTE:** Promulgated by the Louisiana Workforce Commission, Office of Workers Compensation Administration, LR 37:1684 (June 2011), amended LR 46:198 (February 2020).

### **§2109. Initial Evaluation and Diagnostic Procedures**

A. The OWCA recommends the following diagnostic procedures be considered, at least initially, the responsibility of the workers' compensation carrier to ensure that an accurate diagnosis and treatment plan can be established. Standard procedures that should be utilized when initially diagnosing a work-related chronic pain complaint are listed below.

1. **History and Physical Examination (Hx and PE).** These are generally accepted, well-established, and widely

used procedures that establish the foundation/basis for and dictate subsequent stages of diagnostic and therapeutic procedures. When findings of clinical evaluations and those of other diagnostic procedures are not complementing each other, the objective clinical findings should have preference. The medical records should reasonably document the following.

a. **Medical history**—as in other fields of medicine, a thorough patient history is an important part of the evaluation of chronic pain. In taking such a history, factors influencing a patient's current status can be made clear and taken into account when planning diagnostic evaluation and treatment. It may be necessary to acquire previous medical records. One efficient manner in which to obtain historical information and patient reported functional status is by using a questionnaire. The questionnaire may be sent to the patient prior to the initial visit or administered at the time of the office visit. History should ascertain the following elements:

i. **general information**—general items requested are name, sex, age, birth date, etc;

ii. **level of education**—the level of patient's education may influence response to treatment;

iii. **work history/occupation**—to include both impact of injury on job duties and impact on ability to perform job duties, work history, job description, mechanical requirements of the job, duration of employment, and job satisfaction;

iv. **current employment status;**

v. **marital status;**

vi. **family environment**—Is the patient living in a nuclear family or with friends? Is there or were there, any family members with chronic illness or pain problems? Responses to such questions reveal the nature of the support system or the possibility of conditioning toward chronicity;

vii. **ethnic origin**—Ethnicity of the patient, including any existing language barriers, may influence the patient's perception of and response to pain. There is evidence that providers may under-treat patients of certain ethnic backgrounds due to underestimation of their pain;

viii. **belief system**—Patients should be asked about their value systems, including spiritual and cultural beliefs, in order to determine how these may influence the patient's and family's response to illness and treatment recommendations.

ix. **functional assessment**—Functional ability should be assessed and documented at the beginning of treatment. Periodic assessment should be recorded throughout the course of care to follow the trajectory of recovery. Functional measures are likely to be more reliable over time than pain measures.

(a). **Patient-reported outcomes**, whether of pain or function, are susceptible to a phenomenon called response shift. This refers to changes in self-evaluation, which may accompany changes in health status. Patient self-reports may

not coincide with objective measures of outcome, due to reconceptualization of the impact of pain on daily function and internal recalibration of pain scales. Response shift may obscure treatment effects in clinical trials and clinical practice, and it may lead to apparent discrepancies in patient-reported outcomes following treatment interventions. While methods of measuring and accounting for response shift are not yet fully developed, understanding that the phenomenon exists can help clinicians understand what is happening when some measures of patient progress appear inconsistent with other measures of progress.

x. activities of daily living (ADLs)—Pain has a multidimensional effect on the patient that is reflected in changes in usual daily vocational, social, recreational, and sexual activities;

xi. past and present psychological problems;

xii. history of abuse—physical, emotional, sexual;

xiii. history of disability in the family;

xiv. sleep disturbances: poor sleep has been shown to increase patient's self-perceived pain scores. Pre-injury and post-injury sleep should be recorded.

xv. causality—How did this injury occur? Was the problem initiated by a work-related injury or exposure? Patient's perception of causality (e.g., was it their fault or the fault of another).

b. Pain History. Characterization of the patient's pain and of the patient's response to pain is one of the key elements in treatment.

i. site of pain—localization and distribution of the pain help determine the type of pain the patient has (i.e., central versus peripheral);

ii. pain diagram drawings to document the distribution of pain.

iii. Visual Analog Scale (VAS)—Current pain, highest pain level, and usual pain level may be recorded. Include a discussion of the range of pain during the day and how activities, use of modalities, and other actions affect the intensity of pain.

iv. duration—including intermittent pain, activity related pain;

v. place of onset—circumstances during which the pain began (e.g., an accident, an illness, a stressful incident, or spontaneous onset);

vi. pain characteristics—such as burning, shooting, stabbing, and aching. Time of pain occurrence, as well as intensity, quality, and radiation, give clues to the diagnosis and potential treatment. Quality of pain can be helpful in identifying neuropathic pain which is normally present most of the day, at night, and is often described as burning;

vii. list of activities which aggravate or exacerbate, ameliorate, decrease, or have no effect on the level of pain;

viii. associated symptoms—Does the patient have numbness or paresthesia, dysesthesia, weakness, bowel or bladder dysfunction, altered temperature, increased sweating, cyanosis or edema? Is there local tenderness, allodynia, hyperesthesia, or hyperalgesia? Does the patient have constitutional symptoms such as fevers, chills, night sweats, unexplained weight loss, or pain that awakes them from a deep sleep at night?

c. Medical management history:

i. prior treatment—chronological review of medical records including previous medical evaluations and response to treatment interventions. In other words, what has been tried and which treatments have helped?;

ii. prior surgery—If the patient has had prior surgery specifically for the pain, he/she is less likely to have a positive outcome;

iii. medications—history of and current use of medications, including opioids, over the counter medications and herbal/dietary supplements, to determine drug usage (or abuse) interactions and efficacy of treatment. Drug allergies and other side effects experienced with previous or current medication therapy and adherence to currently prescribed medications should be documented. Ideally, this includes dosing schedules as reported by the patient or patient representative. Information should be checked against the Louisiana Prescription Monitoring Program (PMP), offered by the Louisiana Pharmacy Board;

iv. review of systems check list—Determine if there is any interplay between the pain complaint and other medical conditions;

v. psychosocial functioning—determine if the following are present: current symptoms of depression or anxiety; evidence of stressors in the workplace or at home, and past history of psychological problems. Other confounding psychosocial issues may be present, including the presence of psychiatric disease. Due to the high incidence of co-morbid problems in populations that develop chronic pain, it is recommended that patients diagnosed with Chronic Pain be referred for a full psychosocial evaluation;

vi. diagnostic tests—All previous radiological and laboratory investigations should be reviewed;

vii. pre-existing conditions—Treatment of these conditions is appropriate when the pre-existing condition affects recovery from chronic pain;

viii. family history pertaining to similar disorders.

d. Substance use/abuse

i. alcohol use;

ii. smoking history and use of nicotine replacements;

iii. history of current and prior prescription and recreational drug use and abuse;

iv. the use of caffeine or caffeine-containing beverages;

v. substance abuse information may be only fully obtainable from multiple sources over time. Patient self-reports may be unreliable. Patient self-reports should always be checked against medical records.

e. Other factors affecting treatment outcome:

i. compensation/disability/litigation;

ii. treatment expectations—what does the patient expect from treatment: complete relief of pain or reduction to a more tolerable level?

iii. Other scales may be used to identify cases which are likely to require more complex care. Examples include:

(a). fear avoidance beliefs questionnaire;

(b). tampa scale of kinesiophobia;

(c). pain catastrophizing scale.

f. Physical Examination

i. neurologic evaluation—includes cranial nerves survey, muscle tone and strength, atrophy, detailed sensory examination (see ii-below), motor evaluation (station, gait, coordination), reflexes (normal tendon reflexes and presence or absence of abnormal reflexes such as frontal lobe release signs or upper motor neuron signs), cerebellar testing, signs suggestive of a sensory ataxia (positive Romberg, impaired proprioception, etc.), and provocative neurological maneuvers.

ii. sensory evaluation—A detailed sensory examination is crucial in evaluating a patient with chronic pain complaints. Quantitative sensory testing, such as Semmes-Weinstein, may be useful tools in determining sensory abnormalities. Ideally, the examination should determine if the following sensory signs are present and consistent on repeated examination:

(a). Hyperalgesia;

(b). Hyperpathia;

(c). Paresthesia;

(d). Dysesthesia;

(e). Mechanical Allodynia—static versus dynamic;

(f). Thermal Allodynia;

(g). Hypoesthesia;

(h). Hyperesthesia;

(i). Summation.

iii. musculoskeletal evaluation—range of motion, segmental mobility, musculoskeletal provocative maneuvers, palpation, observation, and functional activities. All joints, muscles, ligaments, and tendons should be examined for asymmetry, swelling, laxity, and tenderness. A portion of the musculoskeletal evaluation is the myofascial examination.

The myofascial examination includes palpating soft tissues for evidence of tightness and trigger points.

iv. evaluation of non-physiologic findings:

(a). Waddell’s Signs cannot be used to predict or diagnose malingering. It is not an appropriate test for assessing non-physiologic causes of low back pain. The sole purpose of the Waddell’s signs is to identify low back pain patients who may need further psychosocial assessment prior to surgery. Refer to Personality/Psychological/Psychosocial Evaluation.

(b). Variabilities on formal exam including variable sensory exam, inconsistent tenderness, and/or swelling secondary to extrinsic sources.

(c). Inconsistencies between formal exam and observed abilities of range-of-motion, motor strength, gait and cognitive/emotional state should be noted in the assessment.

2. Personality /Psychosocial/ Psychiatric/  
Psychological Evaluation

a. These are generally accepted and well-established and widely used diagnostic procedures not only with selected use in acute pain problems, but also with more widespread use in subacute and chronic pain populations.

i. Diagnostic evaluations should distinguish between conditions that are pre-existing, aggravated by the current injury, or work related.

b. Psychosocial evaluations should determine if further psychosocial or behavioral interventions are indicated for patients diagnosed with chronic pain. The interpretations of the evaluation should provide clinicians with a better understanding of the patient in his or her social environment, thus allowing for more effective rehabilitation. Psychosocial assessment requires consideration of variations in pain experience and expression resulting from affective, cognitive, motivational and coping processes, and other influences such as gender, age, race, ethnicity, national origin, religion, sexual orientation, disability, language, or socioeconomic status.

c. While there is some agreement about which psychological factors need to be assessed in patients with chronic pain, a comprehensive psychological evaluation should attempt to identify both primary psychiatric risk factors or “red flags” (e.g., psychosis, active suicidality) as well as secondary risk factors or “yellow flags” (e.g., moderate depression, job dissatisfaction). Significant personality disorders must be taken into account when considering a patient for spinal cord stimulation and other major procedures.

d. Psychometric testing is a valuable component of a consultation to assist the physician in making a more effective treatment plan. There is good evidence that psychometric testing can have significant ability to predict medical treatment outcome. For example, one study found that psychometric testing exceeded the ability of discography to predict disability in patients with low back

pain. Pre-procedure psychiatric/psychological evaluation must be done prior to diagnostic confirmatory testing for a number of procedures. Examples include discography for fusion, spinal cord stimulation, or intrathecal drug delivery systems, and a psychologist employed by the physician planning to perform the procedure should not do them and they should not be done by a psychologist employed by the physician planning to perform the procedure.

e. In many instances, psychological testing has validity comparable to that of commonly used medical tests; for example, the correlation between high trait anger and blood pressure is equal to the correlation between reduced blood flow and the failure of a synthetic hemodialysis graft. Thus, psychometric testing may be of comparable validity to medical tests and may provide unique and useful diagnostic information.

f. All patients who are diagnosed as having chronic pain should be referred for a psychosocial evaluation, as well as concomitant interdisciplinary rehabilitation treatment. This referral should be performed in a way so as to not imply that the patient's claims are invalid or that the patient is malingering or mentally ill. Even in cases where no diagnosable mental condition is present, these evaluations can identify social, cultural, coping, and other variables that may be influencing the patient's recovery process and may be amenable to various treatments including behavioral therapy. As pain is understood to be a biopsychosocial phenomenon, these evaluations should be regarded as an integral part of the assessment of chronic pain conditions.

i. Qualifications

(a). A psychologist with a PhD, PsyD, or EdD credentials or a physician with Psychiatric MD/DO credentials may perform the initial comprehensive evaluations. It is preferable that these professionals have experience in diagnosing and treating chronic pain disorders and/or working with patients with physical impairments.

(b). Psychometric tests should be administered by psychologists with a PhD, PsyD, or EdD or health professionals working under the supervision of a doctorate level psychologist. Physicians with appropriate training may also administer such testing, but interpretation of the tests should be done by properly credentialed mental health professionals.

ii. Clinical Evaluation. Special note to health care providers: most providers are required to adhere to the federal regulations under the Health Insurance Portability and Accountability Act (HIPAA). Unlike general health insurers, workers' compensation insurers are not required to adhere to HIPAA standards. Thus, providers should assume that sensitive information included in a report sent to the insurer could be forwarded to the employer. It is recommended that the health care provider either obtain a full release from the patient regarding information that may go to the employer or not include sensitive health information not directly related to the work related conditions in reports sent to the insurer.

(a). All chronic pain patients should have a clinical evaluation that addresses the following areas recalling that not all details should be included in the report sent to the insurer due to the HIPAA issue noted above:

(i).history of injury—The history of the injury should be reported in the patient's words or using similar terminology. Caution must be exercised when using translators.

- [a].nature of injury;
- [b].psychosocial circumstances of the injury;
- [c].current symptomatic complaints;
- [d].extent of medical corroboration;
- [e].treatment received and results;
- [f].adherence with treatment;

[g].coping strategies used, including perceived locus of control, catastrophizing, and risk aversion;

[h].perception of medical system and employer;

[i].history of response to prescription medications.

(ii). health history

- [a].nature of injury;
- [b].medical history;

[c].psychiatric history: to include past diagnoses, counseling, medications, and response to treatment;

[d].history of substance related and addictive disorders to include: alcohol, opioids, medications (sedative, hypnotic, and anxiolytic), stimulants, prescriptions drug abuse, nicotine use and other substances of abuse/dependence;

- [e].activities of daily living;
- [f].past, recent, and concurrent stressors.

[g].previous injuries, including disability, impairment, and compensation

(iii).psychosocial history

[a]. childhood history, including abuse/neglect;

[b].educational history;

[c].family history, including disability;

[d].marital history and other significant adulthood activities and events;

[e]. legal history, including but not limited to substance use related, domestic violence, criminal and civil litigation;

[f].employment history;

[g].military duty: Because post-traumatic stress disorder (PTSD) might be an unacceptable condition for many military personnel to acknowledge, it may be prudent to screen initially for signs of depression or anxiety—both of which may be present in PTSD;

[h].signs of pre-injury psychological dysfunction;

[i].financial history.

[j].current living situation including roommates, family, intimate partners, and financial support;

[k].prior level of function including self-care, community, recreational, and employment activities.

(iv).Psychological test results, if performed

(v). assessment of any danger posed to self or others.

(vi).Current psychiatric diagnosis consistent with the standards of the American Psychiatric Association’s Diagnostic and Statistical Manual of Mental Disorders.

(vii). Pre-existing psychiatric conditions. Treatment of these conditions is appropriate when the pre-existing condition affects recovery from chronic pain.

(viii). causality—to address medically probable cause and effect, and to distinguish pre-existing psychological symptoms, traits, and vulnerabilities from current symptoms.

(ix).Treatment recommendations with respect to specific goals, frequency, timeframes, and expected outcomes.

(x). mental status exam including orientation, cognition, activity, speech, thinking, affect, mood, and perception. May include screening tests such as the mini mental status exam or frontal assessment battery if appropriate.

iii. Tests of Psychological Functioning. Psychometric Testing is a valuable component of a consultation to assist the physician in making a more effective treatment plan. Psychometric testing is useful in the assessment of mental conditions, pain conditions, cognitive functioning, treatment planning, vocational planning, and evaluation of treatment effectiveness. While there is no general agreement as to which psychometric tests should be specifically recommended for psychological evaluations of chronic pain conditions, standardized tests are preferred over those which are not for assessing diagnosis. Generally, it is helpful if tests consider the following issues: validity, physical symptoms, affective disorders, character disorders and traits, and psychosocial history. Character strengths that support the healing/rehabilitative process should also be evaluated and considered with any dysfunctional behavior patterns or pathology to more accurately assess the patient’s prognosis and likely response to a proposed intervention. In contrast, non-standardized tests can be useful for “ipsative” outcome assessment, in which a test is administered more

than once and a patient’s current and past reports are compared. It is appropriate for the mental health provider to use their discretion and administer selective psychometric tests within their expertise and within standards of care in the community. Use of screening psychometrics by non-mental health providers is encouraged, but mental health provider consultation should always be utilized for chronic pain patients in which invasive palliative pain procedures or chronic opiate treatment is being contemplated. Some of these tests are available in Spanish and other languages, and many are written at a sixth grade reading level. Examples of frequently used psychometric tests performed include, but not limited to, the following.

(a). Comprehensive Inventories for Medical Patients

(i). Battery for Health Improvement, 2nd Edition (BHI-2);

(ii).Millon Behavioral Medical Diagnostic (MBMD);

(b). Comprehensive Psychological Inventories.

(i). Millon Clinical Multiaxial Inventory;

(ii). Minnesota Multiphasic Personality Inventory, 2nd Edition (MMPI-2).

(iii).Personality Assessment Inventory (PAI).

(c). Brief Multidimensional Screens for Medical Patients. Treating providers, to assess a variety of psychological and medical conditions, including depression, pain, disability and others, may use brief instruments. These instruments may also be employed as repeated measures to track progress in treatment, or as one test in a more comprehensive evaluation. Brief instruments are valuable in that the test may be administered in the office setting and hand scored by the physician. Results of these tests should help providers distinguish which patients should be referred for a specific type of comprehensive evaluation.

(i). Brief Battery for Health Improvement, 2nd Edition (BBHI-2);

(ii). Pain Patient Profile (P-3);

(iii). SF-36®;

(iv). Sickness Impact Profile (SIP);

(v). McGill Pain Questionnaire (MPQ);

(vi). McGill Pain Questionnaire—Short Form (MPQ-SF);

(vii). Oswestry Disability Questionnaire;

(viii). Visual Analog Scales (VAS);

(ix). Numerical Rating Scale (NRS);

(x). Chronic Pain Grade Scale (CPGS);

(xi). Pain Catastrophizing Scale (PCS).



(d). Brief Multidimensional Screens for Psychiatric Patients. These tests are designed for detecting various psychiatric syndromes, but in general are more prone to false positive findings when administered to medical patients.

- (i). Brief Symptom Inventory (BSI);
- (ii). Brief Symptom Inventory—18 (BSI-18);
- (iii). Symptom Check List -90 Revised (SCL 90 R).

(e). Brief Specialized Psychiatric Screening Measures:

- (i). Beck Depression Inventory (BDI);
- (ii). Center of Epidemiologic Studies—Depression Questionnaire (CES-D);

NOTE: Designed for assessment of psychiatric patients, not pain patients, which can bias results, and this should be a consideration when using.

(iii). Brief Patient Health Questionnaire from PRIME - MD. (The PHQ-9 may also be used as a depression screen.);

- (iv). Zung Depression Questionnaire;

NOTE: The Zung Depression Scale must be distinguished from the Modified Zung Depression scale used by the DRAM (a QPOP measure). The Zung Depression Scale has different items and a different scoring system than the Modified Zung Depression scale, making the cutoff scores markedly different. The cutoff scores for one measure cannot be used for the other.

(v). General Anxiety Disorder 7-item scale (GAD-7).

3. Diagnostic Studies. Imaging of the spine and/or extremities is a generally accepted, well-established, and widely used diagnostic procedure when specific indications, based on history and physical examination, are present. Practitioners should be aware of the radiation doses associated with various procedures and provide appropriate warnings to patients. Unnecessary CT scans or X-rays increase the lifetime risk of cancer death. Physicians should refer to individual OWCA guidelines for specific information about specific testing procedures. Tests should be performed to rule in or out specific diagnoses especially cases that are difficult to diagnose or fail to progress.

a. Radiographic Imaging, MRI, CT, bone scan, radiography, and other special imaging studies may provide useful information for many musculoskeletal disorders causing chronic pain. It is probably most helpful in ruling out rare, significant diagnoses that may present with pain, such as metastatic cancer. Most imaging is likely to demonstrate aging changes which are usually not pathologic. However, it is good to remember every medical condition can be exacerbated. Refer to specific OWCA Medical Treatment Guidelines for details. Before the test is performed, patients should be informed of the purpose of the exam (e.g., to rule out unsuspected cancer) and the likelihood of finding non-pathologic changes that are part of the normal aging process.

b. Electrodiagnostic studies may be useful in the evaluation of patients with suspected myopathic or neuropathic disease and may include Nerve Conduction Studies (NCS), Standard Needle Electromyography, or Somatosensory Evoked Potential (SSEP). The evaluation of electrical studies is complex and should be performed by specialists who are well trained in the use of this diagnostic procedure.

c. Special testing procedures may be considered when attempting to confirm the current diagnosis or reveal alternative diagnosis. Additional special tests may be performed at the discretion of the physician.

d. Testing for Complex Regional Pain Syndrome (CRPS-I) or Sympathetically Maintained Pain (SMP) is described in the OWCA's Complex Regional Pain Syndrome/Reflex Sympathetic Dystrophy Medical Treatment Guidelines.

4. Laboratory testing is a generally accepted, well-established and widely used procedure.

a. Patients should be carefully screened at the initial exam for signs or symptoms of diabetes, hypothyroidism, arthritis, and related inflammatory diseases. For patients at risk for sleep apnea, testing may be appropriate depending on medication use and issues with insomnia. The presence of concurrent disease does not refute work-relatedness of any specific case. This frequently requires laboratory testing. When a patient's history and physical examination suggest infection, metabolic or endocrinologic disorders, tumorous conditions, systemic musculoskeletal disorders (e.g., rheumatoid arthritis or ankylosing spondylitis), or problems potentially related to medication (e.g., renal disease and non-steroidal anti-inflammatory medications), then laboratory tests, including, but not limited to the following can provide useful diagnostic information:

i. thyroid stimulating hormone (TSH) for hypothyroidism;

ii. diabetic screening: recommended for men and women with a BMI over 30, patients with a family history of diabetes, those from high risk ethnic groups, and patients with a previous history of impaired glucose tolerance. There is some evidence that diabetic patients with upper extremity disorders have sub-optimal control of their diabetes;

iii. serum protein electrophoresis;

iv. sedimentation rate and C-reactive protein (CRP) are nonspecific but elevated in infection, neoplastic conditions, and rheumatoid arthritis. Other screening tests to rule out inflammatory or autoimmune disease may be added when appropriate;

v. serum calcium, phosphorus, uric acid, alkaline, and acid phosphatase for metabolic, endocrine and neoplastic conditions;

vi. complete blood count (CBC), liver, and kidney function profiles for metabolic or endocrine disorders or for adverse effects of various medications;

vii. bacteriological (microorganism) work-up for wound, blood, and tissue;

viii. vitamin B12 levels may be appropriate for some patients.

b. The OWCA recommends that the workers' compensation carrier cover initial lab diagnostic procedures to ensure that an accurate diagnosis and treatment plan is established. When an authorized treating provider has justification for the test, insurers should cover the costs. Laboratory testing may be required periodically to monitor patients on chronic medications.

#### 5. Injections-Diagnostic

a. Spinal Diagnostic Injections. Diagnostic spinal injections are commonly used in chronic pain patients and they usually have been performed previously in the acute or subacute stage. They may rarely be necessary for aggravations of low back pain. Refer to the OWCA Low Back Pain Medical Treatment Guideline for indications.

b. Diagnostic Peripheral nerve blocks such as Genicular Nerves, 3rd Occipital, nerves, Greater and Lesser Occipital nerves, intercostal nerves, Ilioinguinal nerves, iliohypogastric nerves, lateral femoral cutaneous nerves, medial branch facet nerves (cervical, thoracic and lumbar), sacral lateral branches of Sacroiliac joints, Selective nerve root blocks and transforaminal epidural injections and other pure sensory nerves suspected of causing pain. Also include diagnostic facet joint injection as a diagnostic block.

c. Medial Branch Facet Blocks (Cervical, Thoracic and Lumbar) and Sacral Lateral Branch Blocks. If provide 80 percent or more pain reduction as measured by a numerical pain index scale within one hour of the medial branch blocks up to three levels per side, then rhizotomy of the medial branch nerves, up to four nerves per side, may be done without confirmation block. If the initial set of medial branch blocks provides less than 80 percent but at least 50 percent pain reduction as measured by a numerical pain index scale or documented functional improvement, the medial branch block should be repeated for confirmation before a rhizotomy is performed. If 50 percent or greater pain reduction is achieved as measured by the NPIS with two sets of medial branch blocks for facet joint pain, then rhizotomy may be performed.

d. In general, relief should last for at least the duration of the local anesthetic used and should significantly result in functional improvement and relief of pain. Refer to Injections- Spinal Therapeutic for information on other specific therapeutic injections.

6. Special tests are generally well-accepted tests and are performed as part of a skilled assessment of the patient's capacity to return to work, his/her strength capacities, and/or physical work demand classifications and tolerance. The procedures in this Subsection are listed in alphabetical order.

a. Computer-enhanced evaluations. These may include isotonic, isometric, isokinetic and/or isoinertial measurement of movement, range of motion (ROM),

endurance, or strength. Values obtained can include degrees of motion, torque forces, pressures, or resistance. Indications include determining validity of effort, effectiveness of treatment and demonstrated motivation. These evaluations should not be used alone to determine return to work restrictions.

i. Frequency. One time for evaluation, one for mid-treatment assessment, and one at final evaluation.

b. Functional Capacity Evaluation (FCE): This is a comprehensive or modified evaluation of the various aspects of function as they relate to the worker's ability to return-to-work. FCEs should not be used as the sole criteria to diagnose malingering. Areas such as endurance, lifting (dynamic and static), postural tolerance, specific range of motion (ROM), coordination and strength, worker habits, employability as well as psychosocial aspects of competitive employment may be evaluated. Reliability of patient reports and overall effort during testing is also reported. Components of this evaluation may include: musculoskeletal screen; cardiovascular profile/aerobic capacity; coordination; lift/carrying analysis; job-specific activity tolerance; maximum voluntary effort; pain assessment/psychological screening; non-material and material handling activities. Standardized national guidelines (such as National Institute for Occupational Safety and Health (NIOSH)) should be used as the basis for FCE recommendations.

i. Frequency: Once when the patient is unable to return to the pre-injury position and further information is desired to determine permanent work restrictions. Prior authorization is required for repeat FCEs.

ii. Most studies of FCEs were performed on chronic low back cases. There is some evidence that an FCE fails to predict which injured workers with chronic low back pain will have sustained return to work. Another cohort study concluded that there was a significant relation between FCE information and return to work, but the predictive efficiency was poor. There is some evidence that time off work and gender are important predictors for return to work, and floor-to-waist lifting may also help predict return to work; however, the strength of that relationship has not been determined.

iii. A full review of the literature reveals no evidence to support the use of FCEs to prevent future injuries. There is some evidence in chronic low back pain patients that FCE task performance is weakly related to time on disability and time for claim closure, and even claimants who fail on numerous physical performance FCE tasks may be able to return to work. These same issues may exist for lower extremity issues.

iv. Depth and breadth of FCE should be assessed on a case-by-case basis and should be determined by tester and/or referring medical professional. In many cases, a work tolerance screening or return to work performance will identify the ability to perform the necessary job tasks. There is some evidence that a short form FCE reduced to a few tests produces a similar predictive quality compared to the

longer two-day version of the FCE regarding length of disability and recurrence of a claim after return to work.

v. When an FCE is being used to determine return to a specific jobsite, the provider is responsible for fully understanding the physical demands and the duties of the job that the worker is attempting to perform. A jobsite evaluation is usually necessary. A job description should be reviewed by the provider and FCE evaluator prior to this evaluation. FCEs cannot be used in isolation to determine work restrictions. It is expected that the FCE may differ from both self-report of abilities and pure clinical exam findings in chronic pain patients. The length of a return to work evaluation should be based on the judgment of the referring physician and the provider performing the evaluation. Since return to work is a complicated multidimensional issue, multiple factors beyond functional ability and work demands should be considered and measured when attempting determination of readiness or fitness to return to work. FCEs should not be used as the sole criteria to diagnose malingering.

c. Job site evaluation is a comprehensive analysis of the physical, mental, and sensory components of a specific job. The goal of the Job Site evaluation is to identify any job modification needed to ensure the safety of the employee upon return to work. These components may include, but are not limited to: postural tolerance (static and dynamic); aerobic requirements; range of motion; torque/force; lifting/carrying; cognitive demands; social interactions; visual perceptual; environmental requirements of a job; repetitiveness; essential functions of a job; and ergonomic set up. Job descriptions provided by the employer are helpful but should not be used as a substitute for direct observation.

i. Frequency: One time with additional visits as needed for follow-up per job site.

ii. Jobsite evaluation and alteration should include input from a health care professional with experience in ergonomics or a certified ergonomist, the employee, and the employer. The employee must be observed performing all job functions in order for the jobsite evaluation to be a valid representation of a typical workday. If the employee is unable to perform the job function for observation, a co-worker in an identical job position may be observed instead. Periodic follow-up is recommended to assess the effectiveness of the intervention and need for additional ergonomic changes.

iii. A jobsite evaluation may include observation and instruction of how work is done, what material changes (desk, chair) should be made, and determination of readiness to return to work.

iv. Requests for a jobsite evaluation should describe the expected goals for the evaluation. Goals may include but are not limited to the following:

(a). to determine if there are potential contributing factors to the person's condition and/or for the physician to assess causality;

(b). to make recommendations for and to assess the potential for ergonomic changes;

(c). to provide a detailed description of the physical and cognitive job requirements;

(d). to assist patients in their return to work by educating them on how they may be able to do their job more safely in a bio-mechanically appropriate manner;

(e). to give detailed work/activity restrictions.

d. Vocational Assessment. Once an authorized practitioner has reasonably determined and objectively documented that a patient will not be able to return to his/her former employment and can reasonably prognosticate final restrictions, implementation of a timely vocational assessment can be performed. The vocational assessment should provide valuable guidance in the determination of future rehabilitation program goals. It should clarify rehabilitation goals, which optimize both patient motivation and utilization of rehabilitation resources. If prognosis for return to former occupation is determined to be poor, except in the most extenuating circumstances, vocational assessment should be implemented within 3 to 12 months post-injury. Declaration of Maximum Medical Improvement (MMI) should not be delayed solely due to lack of attainment of a vocational assessment.

i. Frequency: One time with additional visits as needed for follow-up

e. Work tolerance screening (Fitness for Duty) is a determination of an individual's tolerance for performing a specific job based on a job activity or task. It may include a test or procedure to specifically identify and quantify work-relevant cardiovascular, physical fitness and postural tolerance. It may also address ergonomic issues affecting the patient's return-to-work potential. May be used when a full FCE is not indicated. In order for a work tolerance to be performed in place of a FCE, an updated job description must be provided to the tester.

i. Frequency. One time for initial screen. May monitor improvements in strength every three to four weeks up to a total of six visits.

AUTHORITY NOTE: Promulgated in accordance with R.S. 23:1203.1.

HISTORICAL NOTE: Promulgated by the Louisiana Workforce Commission, Office of Workers Compensation Administration, LR 37:1685 (June 2011), amended LR 46:199 (February 2020).

### **§2111. Therapeutic Procedures—Non-Operative**

A. Non-operative therapeutic rehabilitation is applied to patients with chronic and complex problems of de-conditioning and functional disability. Treatment modalities may be utilized sequentially or concomitantly depending on chronicity and complexity of the problem, and anticipated therapeutic effect. Treatment plans should always be based on a diagnosis utilizing appropriate diagnostic procedures.

B. All treatment plans begin with shared decision making with the patient. Before initiation of any therapeutic

procedure, an authorized treating physician, employer, and insurer should consider these important issues in the care of the injured worker:

1. Patients undergoing therapeutic procedure(s) should be released or returned to modified or restricted duty during their rehabilitation at the earliest appropriate time. Refer to Return-to-Work in this Section for detailed information.

2. Reassessment of the patient's status in terms of functional improvement should be documented after each treatment. If patients are not responding within the recommended time periods, alternative treatment interventions, further diagnostic studies or specialist and/or surgeon consultations should be pursued. Continued treatment should be monitored using objective measures such as:

- a. return-to-work or maintaining work status;
- b. fewer restrictions at work or performing activities of daily living (ADL);
- c. decrease in usage of medications related to the work injury; and
- d. measurable functional gains, such as increased range of motion, documented increase in strength, increased ability to stand, sit or lift, or patient completed functional evaluations.

3. Clinicians should provide and document education to the patient. No treatment plan is complete without addressing issues of individual and/or group patient education as a means of facilitating self-management of symptoms.

4. Psychological or psychosocial screening should be performed on all chronic pain patients.

C. The following procedures are listed in alphabetical order.

#### 1. Acupuncture

a. Overview. When acupuncture has been studied in randomized clinical trials, it is often compared with sham acupuncture and/or no acupuncture (usual care). The differences between true acupuncture and usual care have been moderate but clinically important. These differences can be partitioned into two components: non-specific effects and specific effects. Non-specific effects include patient beliefs and expectations, attention from the acupuncturist, administration of acupuncture in a relaxing setting, and other components of what is often called the placebo effect. Specific effects refer to any additional effects which occur in the same setting of expectations and attention, but they are attributable to the penetration of the skin in the specific, classic acupuncture points on the surface of the body by the needles themselves.

i. A sham procedure is intended as a non-therapeutic procedure that appears similar to the patient as the purported therapeutic procedure being tested. In most controlled studies, sham and classic acupuncture have produced similar effects. However, the sham controlled

studies have shown consistent advantages of both true and sham acupuncture over no acupuncture when the studies have included a third comparison group that was randomized to usual medical care. Having this third comparison group has been advantageous in the interpretation of the non-specific effects of acupuncture since the third comparison group controls for some influences on study outcome. These influences include: more frequent contact with providers; the natural history of the condition; regression to the mean; the effect of being observed in a clinical trial; and for biased reporting of outcomes if the follow-up observations are done consistently in all three treatment groups. Controlling for these factors enables researchers to more closely estimate the contextual and personal interactive effects of acupuncture as it is generally practiced.

ii. There is some evidence that in the setting of chronic joint pain arising from aromatase inhibitor treatment of non-metastatic breast cancer, the symptomatic relief from acupuncture is strongly influenced by the expectations with which patients approach treatment, and a patient who expects significant benefits from acupuncture is more likely to derive benefits from sham acupuncture than a patient with low expectations is to derive benefits from real acupuncture. On average, real and sham acupuncture do not lead to significantly different symptom responses, but different treatment expectations do lead to different symptom responses.

iii. Clinical trials of acupuncture typically enroll participants who are interested in acupuncture and who may respond to some of the non-specific aspects of the intervention more than patients who have no interest in or desire for acupuncture. The non-specific effects of acupuncture may not be produced in patients who have no wish to be referred for it.

iv. There is a high quality study which does not support good evidence that true acupuncture is meaningfully superior to sham acupuncture with blunt needles in relieving the bothersomeness of nonspecific low back pain. The overall evidence from similar high quality studies does not support evidence of a treatment difference between true and sham acupuncture. In these studies, 5 to 15 treatments were provided. Comparisons of acupuncture and sham acupuncture have been inconsistent, and the advantage of true over sham acupuncture has been small in relation to the advantage of sham over no acupuncture.

v. Acupuncture is recommended for subacute or chronic pain patients who are trying to increase function and/or decrease medication usage and have an expressed interest in this modality. It is also recommended for subacute or acute pain for patients who cannot tolerate NSAIDs or other medications.

vi. Acupuncture is not the same procedure as dry needling for coding purposes; however, some acupuncturists may use acupuncture treatment for myofascial trigger points. Dry needling is performed specifically on myofascial trigger points. Refer to Trigger Point Injections, and Dry Needling Treatment.

vii. Acupuncture should generally be used in conjunction with manipulative and physical therapy/rehabilitation.

viii. Credentialed practitioners with experience in evaluation and treatment of chronic pain patients must perform evaluations prior to acupuncture treatments. The exact mode of action is only partially understood. Western medicine studies suggest that acupuncture stimulates the nervous system at the level of the brain, promotes deep relaxation, and affects the release of neurotransmitters. Acupuncture is commonly used as an alternative or in addition to traditional Western pharmaceuticals. It may be used when pain medication is reduced or not tolerated; as an adjunct to physical rehabilitation and surgical intervention; and/or as part of multidisciplinary treatment to hasten the return of functional activity. Acupuncture must be performed by practitioners with the appropriate credentials in accordance with state and other applicable regulations. Therefore, if not otherwise within their professional scope of practice and licensure, those performing acupuncture must have the appropriate credentials, such as L.A.c. R.A.c, or Dipl. Ac.

ix. There is good evidence that the small therapeutic effects of needle acupuncture, active laser acupuncture, and sham acupuncture for reducing pain or improving function among patients older than 50 years with moderate to severe chronic knee pain from symptoms of osteoarthritis are due to non-specific effects similar to placebo.

x. The Agency for Healthcare Research and Quality (AHRQ) supports acupuncture as effective for chronic low back pain. There is good evidence that acupuncture is effective in the treatment of low back pain in patients with positive expectations of acupuncture. There is good evidence that acupuncture, true or sham, is superior to usual care for the reduction of disability and pain in patients with chronic nonspecific low back pain, but true and sham acupuncture are likely to be equally effective. There is some evidence that acupuncture is better than no acupuncture for axial chronic low back pain. In summary, there is strong evidence that true or sham acupuncture may be useful for chronic low back pain in patients with high expectations, and it should be used accordingly.

xi. Indications. All patients being considered for acupuncture treatment should have subacute or chronic pain (lasting approximately three to four weeks depending on the condition) and meet the following criteria:

(a). they should have participated in an initial active therapy program; and

(b). they should show a preference for this type of care or previously have benefited from acupuncture; and

(c). they must continue to be actively engaged in physical rehabilitation therapy and return to work.

xii. It is less likely to be successful in patients who are more focused on pain than return to function. Time to produce effect should clearly be adhered to.

b. Acupuncture is the insertion and removal of filiform needles to stimulate acupoints (acupuncture points). Needles may be inserted, manipulated, and retained for a period of time. Acupuncture can be used to reduce pain, reduce inflammation, increase blood flow, increase range-of-motion, decrease the side effect of medication-induced nausea, promote relaxation in an anxious patient, and reduce muscle spasm. Indications include joint pain, joint stiffness, soft tissue pain and inflammation, paresthesia, post-surgical pain relief, muscle spasm, and scar tissue pain.

c. Acupuncture with electrical stimulation is the use of electrical current (micro- amperage or milli-amperage) on the needles at the acupuncture site. It is used to increase effectiveness of the needles by continuous stimulation of the acupoint. Physiological effects (depending on location and settings) can include endorphin release for pain relief, reduction of inflammation, increased blood circulation, analgesia through interruption of pain stimulus, and muscle relaxation. It is indicated to treat chronic pain conditions, radiating pain along a nerve pathway, muscle spasm, inflammation, scar tissue pain, and pain located in multiple sites.

d. Other acupuncture modalities may include a combination of procedures to enhance treatment effect. Other procedures may include the use of heat, and soft tissue manipulation/massage. Refer to Therapy- Active (Therapeutic Exercise) and Therapy-Passive sections (Massage and Superficial Heat and Cold Therapy) for a description of these adjunctive acupuncture modalities and time frames.

e. Total time frames for acupuncture and acupuncture with electrical stimulation are not meant to be applied to acupuncture and acupuncture with electrical stimulation separately. The time frames are to be applied to all acupuncture treatments regardless of the type or combination of therapies being provided.

i. time to produce effect: three to six treatments;

ii. frequency: one to three times per week;

iii. optimum duration: one to two months;

iv. maximum duration: 14 treatments within six months.

f. Any of the above acupuncture treatments may extend longer if objective functional gains can be documented or when symptomatic benefits facilitate progression in the patient's treatment program. Treatment beyond 14 treatments must be documented with respect to need and ability to facilitate positive symptomatic or functional gains. Such care should be re-evaluated and documented with each series of treatments.

2. Biofeedback is a form of behavioral medicine that helps patients learn self-awareness and self-regulation skills for the purpose of gaining greater control of their physiology, such as muscle activity, brain waves, and measures of autonomic nervous system activity. Stress-related psycho-physiological reactions may arise as a

reaction to organic pain and in some cases may cause pain. Electronic instrumentation is used to monitor the targeted physiology and then displayed or fed back to the patient visually, auditorily, or tactilely with coaching by a biofeedback specialist. There is good evidence that biofeedback or relaxation therapy is equal in effect to cognitive behavioral therapy for chronic low back pain. There is good evidence that cognitive behavioral therapy, but not behavioral therapy (e.g., biofeedback), shows weak to small effects in reducing pain and small effects on improving disability, mood, and catastrophizing in patients with chronic pain.

a. Indications for biofeedback include cases of musculoskeletal injury in which muscle dysfunction or other physiological indicators of excessive or prolonged stress response affects and/or delays recovery. Other applications include training to improve self-management of pain, anxiety, panic, anger or emotional distress, opioid withdrawal, insomnia/ sleep disturbance, and other central and autonomic nervous system imbalances. Biofeedback is often utilized for relaxation training. Mental health professionals may also utilize it as a component of psychotherapy, where biofeedback and other behavioral techniques are integrated with psychotherapeutic interventions. Biofeedback is often used in conjunction with physical therapy or medical treatment.

b. Recognized types of biofeedback include the following:

i. Electromyogram (EMG): Used for self-management of pain and stress reactions involving muscle tension.

ii. Skin Temperature: Used for self-management of pain and stress reactions, especially vascular headaches.

iii. Respiration Feedback (RFB): Used for self-management of pain and stress reactions via breathing control.

iv. Respiratory Sinus Arrhythmia (RSA): Used for self-management of pain and stress reactions via synchronous control of heart rate and respiration. Respiratory sinus arrhythmia is a benign phenomena which consists of a small rise in heart rate during inhalation, and a corresponding decrease during exhalation. This phenomenon has been observed in meditators and athletes, and is thought to be a psychophysiological indicator of health.

v. Heart Rate Variability (HRV): Used for self-management of stress via managing cardiac reactivity.

vi. Electrodermal Response (EDR,): Used for self-management of stress involving palmar sweating or galvanic skin response.

vii. Electroencephalograph (EEG, QEEG): Used for self-management of various psychological states by controlling brainwaves.

c. The goal in biofeedback treatment is normalizing the physiology to the pre-injury status to the extent possible and involves transfer of learned skills to the workplace and

daily life. Candidates for biofeedback therapy or training must be motivated to learn and practice biofeedback and self-regulation techniques. In the course of biofeedback treatment, patient stressors are discussed and self-management strategies are devised. If the patient has not been previously evaluated, a psychological evaluation should be performed prior to beginning biofeedback treatment for chronic pain. The psychological evaluation may reveal cognitive difficulties, belief system conflicts, somatic delusions, secondary gain issues, hypochondriasis, and possible biases in patient self-reports, which can affect biofeedback. Home practice of skills is often helpful for mastery and may be facilitated by the use of home training tapes.

d. Psychologists or psychiatrists, who provide psycho-physiological therapy which integrates biofeedback with psychotherapy, should be either Biofeedback Certification Institute of America (BCIA) certified or practicing within the scope of their training. All non-licensed health care providers of Biofeedback for chronic pain patients must be BCIA certified and shall have their biofeedback treatment plan approved by the authorized treating psychologist or psychiatrist. Biofeedback treatment must be done in conjunction with the patient's psychosocial intervention. Biofeedback may also be provided by licensed health care providers, who follow a set treatment and educational protocol. Such treatment may utilize standardized material, relaxation tapes, or smart phone apps.

i. time to produce effect: three to four sessions;

ii. frequency: one to two times per week;

iii. optimum duration: five to six sessions;

iv. maximum duration: 10 to 12 sessions.

Treatment beyond 12 sessions must be documented with respect to need, expectation, and ability to facilitate functional gains.

### 3. Complementary Medicine

a. Overview. Complementary Medicine, termed Complementary Alternative Medicine (CAM) in some systems, is a term used to describe a broad range of treatment modalities, a number of which are generally accepted and supported by some scientific literature and others which still remain outside the generally accepted practice of conventional Western Medicine. In many of these approaches, there is attention given to the relationship between physical, emotional, and spiritual well-being. While CAM may be performed by a myriad of both licensed and non-licensed health practitioners with training in one or more forms of therapy, credentialed practitioners should be used when available or applicable.

b. Although CAM practices are diverse and too numerous to list, they can be generally classified into five domains.

i. Alternative Medical Systems. These are defined as medical practices that have developed their own systems of theory, diagnosis, and treatment and have

evolved independent of and usually prior to conventional Western Medicine. Some examples are Traditional Chinese Medicine, Ayurvedic Medicine, Homeopathy, and Naturopathy.<sup>1</sup>

ii. **Mind-Body Interventions.** These include practices such as hypnosis, meditation, bioenergetics, and prayer. Reflexology does not appear to relieve low back pain.

iii. **Biological-Based Practices.** These include herbal and dietary therapy as well as the use of nutritional supplements. To avoid potential drug interactions, supplements should be used in consultation with an authorized treating physician.

iv. **Body-Based Therapy.** This category includes Rolwing bodywork. For information on yoga, please refer to Therapeutic Exercise.

v. **Energy-Based Practices.** Energy-based practices include a wide range of modalities that support physical as well as spiritual and/or emotional healing. Some of the more well-known energy practices include Qi Gong, Tai Chi, Healing Touch, and Reiki. Practices such as Qi Gong and Tai Chi are taught to the patient and are based on exercises the patient can practice independently at home. Other energy-based practices such as Healing Touch and Reiki that involve a practitioner/patient relationship may provide some pain relief. Tai Chi may improve range-of-motion in those with rheumatoid arthritis. There is some evidence that a 10-week tai chi program was effective for improving pain symptoms and disability compared with usual care controls for those who have chronic low back pain symptoms. There is insufficient evidence that the results from Qi Gong are equivalent to exercise therapy.

c. Methods used to evaluate chronic pain patients for participation in CAM will differ with various approaches and with the training and experience of individual practitioners. A patient may be referred for CAM therapy when the patient's cultural background, religious beliefs, or personal concepts of health suggest that an unconventional medical approach might assist in the patient's recovery or when the physician's experience and clinical judgment support a CAM approach. The patient must demonstrate a high degree of motivation to return to work and improve his or her functional activity level while participating in therapy. Other more traditional conservative treatments should generally be attempted before referral to CAM. Treatment with CAM requires prior authorization.

d. All CAM treatments require prior authorization and must include agreed upon number of visits for time to produce functional effects.

e. **Time Frames for Complementary Medicine:**

i. **time to produce effect**—Functional treatment goals and number of treatments for time to produce effect should be set with the practitioner and the patient before the beginning of treatment.

ii. **frequency**—per CAM therapy selected.

iii. **optimum duration**—should be based upon the physician's clinical judgment and demonstration by the patient of positive symptomatic and functional gains. Practitioner provided CAM therapy is not recommended on a maintenance basis.

4. **Direct Cortical Stimulation.** There are several types of cortical stimulation to relieve pain. All of these are undergoing further investigation and are considered experimental at this time. The limited studies available do not allow translation to the workers' compensation chronic pain population. An invasive option is implantation in the epidural motor cortex. Given the invasive nature and lack of evidence applying to the working population, direct cortical stimulation is not recommended.

#### 5. Disturbances of Sleep

a. **Overview.** Disturbances of sleep are common in chronic pain. An essential element of chronic pain treatment is restoration of normal sleep cycles. Although primary insomnia may accompany pain as an independent co-morbid condition, it more commonly occurs secondary to the pain condition itself. Exacerbations of pain often are accompanied by exacerbations of insomnia; the reverse can also occur. Sleep laboratory studies have shown disturbances of sleep architecture in pain patients. Loss of deep slow-wave sleep and increase in light sleep occur and sleep efficiency, the proportion of time in bed spent asleep, is decreased. These changes are associated with patient reports of non-restorative sleep. Sleep apnea may also occur as a primary diagnosis or be caused or exacerbated by opioid and hypnotic use. This should be investigated diagnostically. (Refer to Medications and Medical Management, Opioids).

i. A recent systematic review explored the relationship between sleep and pain. It noted that studies of healthy individuals and those in pain from medical conditions both showed decreased pain thresholds after sleep deprivation. In this report some studies focusing on sleep continuity disruption showed a disruption of the natural pain inhibitory function. Sleep continuity disruption may be one of the most common sleep problems associated with pain. Thus, clinicians should strongly focus on assuring functional sleep for patients.

ii. Many chronic pain patients develop behavioral habits that exacerbate and maintain sleep disturbances. Excessive time in bed, irregular sleep routine, napping, low activity, and worrying in bed are all maladaptive responses that can arise in the absence of any psychopathology. Relaxation training such as progressive relaxation, biofeedback, mindfulness meditation, or imagery training, and other forms of cognitive therapy can reduce dysfunctional beliefs and attitudes about sleep.

iii. There is some evidence that behavioral modification, such as patient education and group or individual counseling with cognitive behavioral therapy, can be effective in reversing the effects of insomnia. Cognitive and behavioral interventions should be undertaken before prescribing medication solely for insomnia. Behavioral modifications are easily implemented and can include:

(a). maintaining a regular sleep schedule, retiring and rising at approximately the same time on weekdays and weekends, regardless of the number of hours slept;

(b). limiting naps to 30 minutes twice per day or less;

(c). avoiding caffeinated beverages after lunchtime;

(d). making the bedroom quiet and comfortable, eliminating disruptive lights, sounds, television sets, pets, and keeping a bedroom temperature of about 65°F;

(e). avoiding alcohol or nicotine within two hours of bedtime;

(f). avoiding large meals within two hours of bedtime;

(g). avoiding exposure to TV screens or computers within two hours of bedtime.

(h). exercising vigorously during the day, but not within two hours of bedtime, since this may raise core temperature and activate the nervous system;

(i). associating the bed with sleep and sexual activity only, using other parts of the home for television, reading and talking on the telephone;

(j). leaving the bedroom when unable to sleep for more than 20 minutes, and returning to the bedroom when ready to sleep again;

(k). reducing time in bed to estimated typical sleeping time;

(l). engaging in relaxing activities until drowsy.

b. Behavioral modifications should be trialed before the use of hypnotics. Reinforcing these behaviors may also decrease hypnotic use and overall medication costs. Some patients may use other medications to assist in sleep, such as: trazadone, amitriptyline, doxepin, or low doses of melatonin. There is some evidence that group cognitive behavioral therapy reduces the severity and daytime consequences of insomnia for at least six months. There is some evidence that Ramelteon, while producing a small amount of reduction in sleep latency, does not appreciably increase total sleep time or daytime function. There is some evidence that a dietary supplement containing melatonin, magnesium, and zinc, conveyed in pear pulp, taken one hour before bedtime, results in significantly better quality of sleep and quality of life than a placebo treatment in long-term care facility residents aged 70 and older with primary insomnia.

c. Many medications used in chronic pain can affect the sleep cycle. There is some evidence that the following medications exert different effects with respect to sleep variables. Total sleep time and REM sleep duration are likely to be greater with pregabalin than with duloxetine or amitriptyline. However, pregabalin is likely to lead to dizziness and fatigue more frequently than the other drugs, and oxygen desaturation during sleep also appears to be greater with pregabalin.

d. Insomnia requires difficulty initiating or maintaining sleep, waking up early, or insufficient restorative sleep despite adequate opportunity for sleep, as well as, daytime symptoms of sleep deprivation. In general, recommendations for treatment of insomnia include Cognitive Behavioral Therapy.

6. Education/Informed/Shared decision making of the patient and family, as well as the employer, insurer, policy makers, and the community should be the primary emphasis to prevent disability. Unfortunately, practitioners often think of education and informed decision making last, after medications, manual therapy, and surgery.

a. Informed decision making is the hallmark of a successful treatment plan. In most cases, the continuum of treatment from the least invasive to the most invasive (e.g., surgery) should be discussed. The intention is to find the treatment along this continuum which most completely addresses the condition. Patients should identify their personal values and functional goals of treatment at the first visit. It is recommended that specific individual goals are articulated at the beginning of treatment as this is likely to lead to increased patient satisfaction above that achieved from improvement in pain or other physical function. Progress toward the individual functional goals identified should be addressed at follow-up visits and throughout treatment by other members of the health care team as well as an authorized physician.

b. Documentation of the informed decision process should occur whenever diagnostic tests or referrals from an authorized treating physician are contemplated. The informed decision making process asks the patients to set their personal functional goals of treatment and describe their current health status and any concerns they have regarding adhering to the diagnostic or treatment plan proposed. The provider should clearly describe the following as appropriate to the patient:

i. the expected functional outcomes from the proposed treatment or the expected results and plan of action if diagnostic tests are involved;

ii. expected course of illness/injury without the proposed intervention;

iii. any side effects and risks to the patient;

iv. required post-treatment rehabilitation time and impact on work, if any;

v. alternative therapies or diagnostic testing.

c. Before diagnostic tests or referrals for invasive treatment take place, the patient should be able to clearly articulate the goals of the intervention, the general side effects and risks associated with it and his/her decision regarding compliance with the suggested plan. There is some evidence that information provided only by video is not sufficient education.

d. Practitioners must develop and implement an effective strategy and skills to educate patients, employers, insurance systems, policy makers, and the community as a



whole. An education-based paradigm should always start with providing reassuring information to the patient and informed decision making. More in-depth education currently exists within a treatment regimen employing functional restoration, prevention, and cognitive behavioral techniques. Patient education and informed decision making should facilitate self-management of symptoms and prevention.

e. Time Frames for Education/Informed Decision Making

i. Time to produce effect—varies with individual patient.

ii. Frequency—should occur at every visit.

7. Injections—Spinal Therapeutic

a. General Description. The following injections are considered to be reasonable treatment for chronic pain exacerbations when therapy is continuing and specific indications are met. Refer to the OWCA's appropriate Medical Treatment Guideline for indications. Monitored Anesthesia Care is acceptable for diagnostic and therapeutic procedures. For post-MMI care, refer to Injection Therapy Maintenance Management, in this guideline.

b. Steroid Associated Issues

i. The majority of diabetic patients will experience an increase in glucose following steroid injections. Average increases in one study were 125 mg/dL and returned to normal in 48 hours, whereas in other studies, the increased glucose levels remained elevated up to seven days, especially after multiple injections. All diabetic patients should be told to follow their glucose levels carefully over the seven days after a steroid injection. For patients who have not been diagnosed with diabetes, one can expect some increase in glucose due to insulin depression for a few days after a steroid injection. Clinicians may consider diabetic screening tests for those who appear to be at risk for type 2 diabetes.

ii. Intra-articular or epidural injections cause rapid drops in plasma cortisol levels which usually resolve in one to four weeks. There is some evidence that an intra-articular injection of 80 mg of methylprednisolone acetate into the knee has about a 25 percent probability of suppressing the adrenal gland response to exogenous adrenocorticotrophic hormone (ACTH) for four or more weeks after injection, but complete recovery of the adrenal response is seen by week eight after injection. This adrenal suppression could require treatment if surgery or other physiologically stressful events occur.

iii. There is good evidence that there are no significant differences between epidural injections with corticosteroid plus local anesthetic versus local anesthetic alone; however, there are measureable differences with respect to morning cortisol levels at three and six weeks after the injection, suggesting that the corticosteroid injection is capable of inducing suppression of the hypothalamic-pituitary-adrenal axis.

iv. Case reports of Cushing's syndrome, hypopituitarism, and growth hormone deficiency have been reported uncommonly and have been tied to systemic absorption of intra-articular and epidural steroid injections. Cushing's syndrome has also been reported from serial occipital nerve injections and paraspinous injections.

v. Morning cortisol measurements may be ordered prior to repeating steroid injections or prior to the initial steroid injection when the patient has received multiple previous steroid injections.

vi. The effect of steroid injections on bone mineral density (BMD) and any contribution to osteoporotic fractures is less clear. Patients on long-term steroids are clearly more likely to suffer from fractures than those who do not take steroids. However, the contribution from steroid injections to this phenomenon does not appear to be large. A well-controlled, large retrospective cohort study found that individuals with the same risk factors for osteoporotic fractures were 20 percent more likely to suffer a lumbar fracture if they had an epidural steroid injection. The risk increased with multiple injections. Other studies have shown inconsistent findings regarding BMD changes. Thus, the risk of epidural injections must be carefully discussed with the patient, particularly for patients over 60, and repeat injections should generally be avoided unless the functional goals to be reached outweigh the risk for future fracture. Patients with existing osteoporosis or other risk factors for osteoporosis should rarely receive epidural steroid injections.

c. Time Frames for Intra-Articular and Epidural Injections

i. Maximum Duration. Given this information regarding increase in blood glucose levels, effects on the endocrine system, and possible osteoporotic influence, it is suggested that the total dose of corticosteroid for intra-articular and epidural injections be limited to a total of 320 mg per 80 kg patient or 3-4 mg/kg per person per year [all joints or injections combined]

d. Epidural steroid injections (ESI) may include caudal, transforaminal, or interlaminar injections (cervical, thoracic or lumbar).

i. Epidural injections may be used for radicular pain or radiculopathy. If an injection provides at least 50 percent relief, a repeat of the same pain relieving injection may be given at least two weeks apart with fluoroscopic guidance. No more than two levels may be injected in one session. If there is not a minimum of 50 percent pain reduction as measured by a numerical pain index scale or documented functional improvement, similar injections should not be repeated, although the practitioner may want to consider a different approach or different level depending on the pathology. Maximum of two series of three effective pain relieving injections may be done in one year based upon the patient's response to pain and function.

ii. Spinal Stenosis Patients. Refer to the OWCA's Low Back Pain Medical Treatment Guideline for patients with radicular findings and claudication for indications.

iii. For chronic radiculopathy, injections may be repeated. Patients should be reassessed after each injection session for a 50 percent improvement in pain (as measured by accepted pain scales) and/or evidence of functional improvement. A positive result could include a return toward baseline function, return to increased work duties, and a measurable improvement in physical activity goals including return to baseline after an exacerbation.

e. Intradiscal Steroid Injections. There is some evidence that intradiscal steroid injection is unlikely to relieve pain or provide functional benefit in patients with non-radicular back pain; therefore, they are not recommended.

i. Intradiscal injections of other substances such as bone marrow, stem cells, are not recommended at this time due to lack of evidence and possible complications.

f. Transforaminal Injection with Etanercept. Transforaminal injection with a tumor necrosis factor alpha inhibitor is thought to decrease the inflammatory agents which may be associated with the pathophysiology of lumbar radicular pain from a herniated disc.

i. It is not recommended due to the results of a study which showed no advantage over steroids or saline injections.

g. Zygapophyseal (Facet) Injection

i. Description—an accepted intra-articular or pericapsular injection of local anesthetic and corticosteroid with very limited uses. Up to three joints, either unilaterally or bilaterally. Injections may be repeated only when a functional documented response lasts for three months. A positive result would include a return to baseline function as established at MMI, return to increased work duties, and a measurable improvement in physical activity goals including return to baseline after an exacerbation. Injections may only be repeated when these functional and time goals are met and verified by the designated primary physician. May be repeated up to three times a year. There is no justification for a combined facet and medial branch block.

h. Sacroiliac Joint Injection

i. Description—A generally accepted injection of local anesthetic in an intra-articular fashion into the sacroiliac joint under fluoroscopic guidance. May include the use of corticosteroids. Sacroiliac joint injections may be considered either unilaterally or bilaterally. The injection may only be repeated with 50 percent improvement in Visual Analog Scale with documented functional improvement. Should the designated primary physician consider Sacroiliac Joint (lateral Branch Neurotomy), the diagnostic S1-S3 lateral branch blocks would need to be documented with 80 percent to 100 percent improvement in symptoms for the duration of the local anesthetic. Should the diagnostic lateral branch nerve blocks only result in 50 percent to 80 percent

improvement in symptoms then the confirmatory nerve blocks are recommended. In the event that the diagnostic lateral nerve blocks result in less than 50 percent improvement, then the lateral branch neurotomy is not recommended.

ii. Time Frames for Sacroiliac Joint Injections

(a). Maintenance Duration. Four Sacroiliac joint injections and/ or three lateral branch levels four times per year either unilaterally or bilaterally. Injections may be repeated only when a functional documented response lasts for three months. After three Sacroiliac joint injections or three sessions of three lateral branch blocks within one 12-month period, RF Ablation of lateral branches should be considered.

8. Injections—Other (Including Radio Frequency): The following are in alphabetical order.

a. Botulinum Toxin Injection

i. Description—Used to temporarily weaken or paralyze muscles. May reduce muscle pain in conditions associated with spasticity, or dystonia. Neutralizing antibodies develop in at least four percent of patients treated with botulinum toxin type A, rendering it ineffective. Several antigenic types of botulinum toxin have been described. Botulinum toxin type B, first approved by the Food and Drug Administration (FDA) in 2001, is similar pharmacologically to botulinum toxin type A. It appears to be effective in patients who have become resistant to the type A toxin. The immune responses to botulinum toxins type A and B are not cross-reactive, allowing type B toxin to be used when type A action is blocked by antibody. Experimental work with healthy human volunteers suggests that muscle paralysis from type B toxin is not as complete or as long lasting as that resulting from type A. The duration of treatment effect of botulinum toxin type B for cervical dystonia has been estimated to be 12 to 16 weeks. EMG needle guidance may permit more precise delivery of botulinum toxin to the target area.

(a). There is strong evidence that botulinum toxin A has objective and asymptomatic benefits over placebo for cervical dystonia. There is good evidence that a single injection of botulinum toxin type B is more effective than placebo in alleviating the severity and pain of idiopathic cervical dystonia. The duration of effect of botulinum toxin type B is not certain but appears to be approximately 12 to 18 weeks.

(b). There is a lack of adequate evidence supporting the use of these injections to lumbar musculature for the relief of isolated low back pain. There is insufficient evidence to support its use for longer-term pain relief of other myofascial trigger points and it is likely to cause muscle weakness or atrophy if used repeatedly. Examples of such consequences include subacromial impingement, as the stabilizers of the shoulder are weakened by repeated injections of trigger points in the upper trapezii. Therefore, it is not recommended for use for low back pain or other myofascial trigger points.

(c). They may be used for chronic piriformis syndrome. There is some evidence to support injections for electromyographically proven piriformis syndrome. Prior to consideration of botulinum toxin injection for piriformis syndrome, patients should have had marked (80 percent or better) but temporary improvement, verified with demonstrated improvement in functional activities, from three separate trigger point injections. To be a candidate for botulinum toxin injection for piriformis syndrome, patients should have had symptoms return to baseline or near baseline despite an appropriate stretching program after trigger point injections. Botulinum toxin injections of the piriformis muscle should be performed by a physician experienced in this procedure and utilize either ultrasound, fluoroscopy, or EMG needle guidance. Botulinum toxin should be followed by limb strengthening and reactivation.

ii. Indications—for conditions which produce dystonia or piriformis syndrome. It is important to note that dystonia, torticollis, and spasticity are centrally mediated processes that are distinct from spasm, tightness, or myofascial pain. True dystonia is uncommon and consists of a severe involuntary contraction which results in abnormal postures or movements. Cervical dystonia or torticollis is the most common dystonia seen in the work related population. There should be evidence of limited range of motion prior to the injection.

(a). There is insufficient evidence to support its use in myofascial trigger points for longer-term pain relief, and it is likely to cause muscle weakness or atrophy if used repeatedly. Examples of such consequences include subacromial impingement, as the stabilizers of the shoulder are weakened by repeated injections of trigger points in the upper trapezii. Therefore, it is not recommended for use for other myofascial trigger points.

iii. Complications—There is good evidence that cervical botulinum toxin A injections cause transient dysphagia and neck weakness. Allergic reaction to medications, dry mouth, and vocal hoarseness may also occur. Dry mouth and dysphagia occur 15 percent of the time after one injection. Rare systemic effects include flu-like syndrome, weakening of distant muscle. There is an increased risk of systemic effects in patients with motor neuropathy or disorders of the neuromuscular junction.

#### iv. Time Frames for Botulinum Toxin Injections

(a). Time to produce effect: 24 to 72 hours post injection with peak effect by four to six weeks.

(b). Frequency. No less than three months between re-administration. Patients should be reassessed after each injection session for approximately an 80 percent improvement in pain (as measured by accepted pain scales) and evidence of functional improvement for three months. A positive result would include a return to baseline function, return to increased work duties, and measurable improvement in physical activity goals including return to baseline after an exacerbation.

(c). Optimum duration: three to four months.

(d). Maximum duration. Currently unknown. Repeat injections should be based upon functional improvement and therefore used sparingly in order to avoid development of antibodies that might render future injections ineffective. In most cases, not more than four injections are appropriate due accompanying muscle atrophy.

b. Medial Branch Facet Blocks (Cervical, Thoracic and Lumbar). If provide 80 percent or more pain reduction as measured by a numerical pain index scale within one hour of the medial branch blocks up to three levels per side, then rhizotomy of the medial branch nerves, up to four nerves per side, may be done without confirmation block. If the initial set of medial branch blocks provides less than 80 percent but at least 50 percent pain reduction as measured by a numerical pain index scale or documented functional improvement, the medial branch block should be repeated for confirmation before a rhizotomy is performed. If 50 percent or greater pain reduction is achieved with two sets of medial branch blocks for facet joint pain, then rhizotomy may be performed.

c. Peripheral Nerve Blocks. Used to diagnose and treat pain causers such as Genicular Nerves, 3rd Occipital nerves, Greater and Lesser Occipital nerves, intercostal nerves, ilioinguinal nerves, iliohypogastric nerves, lateral femoral cutaneous nerves, medial branch facet nerves (cervical, thoracic and lumbar), sacral lateral branches of Sacroiliac joints, Selective nerve root blocks and other pure sensory nerves suspected of causing pain. A positive diagnostic nerve block that provides at least 50 percent pain reduction and with possible functional improvement is confirmation that Radiofrequency Ablation of said nerve is indicated. This treatment usually provides relief for 6 to 18 months. Maintenance retreatment with RF is indicated after six months if the same pain returns.

d. Prolotherapy. Also known as sclerotherapy, prolotherapy consists of a series of injections of hypertonic dextrose, with or without glycerine and phenol, into the ligamentous structures of the low back. Its proponents claim that the inflammatory response to the injections will recruit cytokine growth factors involved in the proliferation of connective tissue, stabilizing the ligaments of the low back when these structures have been damaged by mechanical insults.

i. There is good evidence that prolotherapy alone is not an effective treatment for chronic low back pain. There is some evidence that prolotherapy of the sacroiliac (SI) joint is longer lasting, up to 15 months, than intra-articular steroid injections. The study was relatively small and long-term blinding was unclear; however, all injections were done under fluoroscopic guidance. Indications included an 80 percent reduction in pain from an SI joint injection with local anesthetic, as well as physical findings of SI joint dysfunction. Lasting functional improvement has not been shown and approximately three injections were required. The injections are invasive, and may be painful to the patient. The use of prolotherapy for low back pain is generally not recommended, as the majority of patients with

SI joint dysfunction will do well with a combination of active therapy and manipulation and not require prolotherapy. However, it may be used in select patients. Prolotherapy is not recommended for other non-specific back pain.

ii. Indications: insufficient functional progress after six months of an appropriate program that includes a combination of active therapy, manual therapy and psychological evaluation and treatment. There should be documented relief from previously painful maneuvers (e.g., Patrick's or Faber's test, Gaenslen, distraction or gapping, and compression test). A positive result from SI joint diagnostic block including improvement in at least three previously identified physical functions. Standards of evaluation should follow those noted in the diagnostic section. Refer to §2109.A.5, Injections-Diagnostic.

iii. At the minimum, manual therapy, performed on a weekly basis per guideline limits by a professional specializing in manual therapy (such as a doctor of osteopathy, physical therapist, or chiropractor) would address any musculoskeletal imbalance causing sacroiliac joint pain such as lumbosacral or sacroiliac dysfunction, pelvic imbalance, or sacral base unleveling. This thorough evaluation would include identification and treatment to resolution of all causal conditions such as iliopsoas, piriformis, gluteal or hamstring tonal imbalance, leg length inequality, loss of motion of the sacrum, lumbar spine or pelvic bones, and ligamentous, visceral or fascial restrictions.

iv. An active therapy program would consist of a functionally appropriate rehabilitation program which is advanced in a customized fashion as appropriate commensurate with the patient's level of strength and core spinal stability. Such a program would include stretching and strengthening to address areas of muscular imbalance as noted above and neuromuscular re-education to address maintenance of neutral spine via core stabilization with concomitant inhibition of lumbar paravertebral muscles. Patients who demonstrate a directional preference are usually not candidates for this procedure and should receive a trial of directional preference therapy.

v. Informed decision making must be documented including a discussion of possible complications and the likelihood of success. It is suggested that a non-injection specialist determine whether all reasonable treatment has been attempted and to verify the physical findings evaluate the individual. Procedures should not be performed in patients who are unwilling to engage in the active therapy and manual therapy necessary to recover.

e. Radio Frequency Ablation—Dorsal Nerve Root Ganglion. Due to the combination of possible adverse side effects, time limited effectiveness, and mixed study results, this treatment is not recommended.

f. Radio Frequency Ablation—Genicular Nerves and other peripheral sensory nerves: genicular nerves are peripheral sensory nerves on the surface of the knee. After total knee arthroplasty, it is believed that peripheral

neuromas or injury occurs in the genicular nerves causing disabling pain. Diagnostic genicular nerve blocks diagnose this problem and must provide at least 50 percent reduction of pain and demonstrated objective functional improvement to warrant Radiofrequency ablation of genicular nerves. This RF Ablation treatment usually provides 6 to 18 months or more of relief. Radiofrequency Ablation of other peripheral sensory nerves listed in Subparagraph 8.c of this Subsection must also follow diagnostic nerve blocks which provide at least 50 percent reduction of pain and possible functional improvement of said nerve.

g. Radio Frequency (RF) Denervation—Medial Branch Neurotomy/Facet Denervation

i. Description. A procedure designed to denervate the facet joint (Cervical, Thoracic and Lumbar) by ablating the corresponding sensory medial branches. Percutaneous radiofrequency is the method generally used. Pulsed radiofrequency at 42 degrees C should not be used as it may result in incomplete denervation. Cooled radiofrequency is generally not recommended due to current lack of evidence.

(a). If the medial branch blocks provide 80 percent or more pain reduction as measured by a numerical pain index scale within one hour of the medial branch blocks, then rhizotomy of the medial branch nerves, up to four nerves per side, may be done. If the first medial branch block provides less than 80 percent but at least 50 percent pain reduction as measured by a numerical pain index scale or documented functional improvement, the medial branch block should be repeated before a rhizotomy is performed. If 50 percent or greater pain reduction is achieved with two sets of medial branch blocks for facet joint pain, then rhizotomy may be performed.

(b). Generally, RF pain relief lasts at least six months and repeat radiofrequency neurotomy can be successful and last longer. RF neurotomy is the procedure of choice over alcohol, phenol, or cryoablation. Permanent images should be recorded to verify placement of the needles.

ii. Needle Placement. Multi-planar fluoroscopic imaging is required for all injections.

iii. Indications—those patients with proven, significant, facetogenic pain. This procedure is not recommended for patients with multiple pain generators, except in those cases where the facet pain is deemed to be greater than 50 percent of the total pain in the given area. Treatment is limited to no more than 3 facet joint levels or four medial branch nerves unilateral or bilateral at any one-treatment session. After RF ablation is completed additional levels adjacent to the original levels may require additional medial branch blocks to identify if there are additional levels requiring RF ablation. The same rules apply to the additional levels, as if the first levels did not exist.

iv. All patients should continue appropriate exercise with functionally directed rehabilitation. Active treatment, which patients will have had prior to the procedure, will frequently require a repeat of the sessions

that may have been previously ordered prior to the facet treatment (Refer to Therapy-Active).

v. Complications: bleeding, infection, or neural injury. The clinician must be aware of the risk of developing a localized neuritis, or rarely, a deafferentation centralized pain syndrome as a complication of this and other neuroablative procedures.

vi. Post-Procedure Therapy—Active Therapy: implementation of a gentle aerobic reconditioning program (e.g., walking) and back education within the first post-procedure week, barring complications. Instruction and participation in a long-term, home-based program of ROM, core strengthening, postural or neuromuscular re-education, endurance, and stability exercises should be accomplished over a period of 4 to 10 visits post-procedure. Patients who are unwilling to engage in this therapy should not receive this procedure.

vii. Requirements for repeat radiofrequency medial branch neurotomy or other peripheral nerve ablation: In some cases, pain may recur. Successful RF neurotomy usually provides from 6 to 18 months or more of relief.

(a). Before a repeat RF neurotomy is done, a confirmatory medial branch injection or diagnostic nerve block should only be performed if the patient's pain pattern presents differently than the initial evaluation. In occasional patients, additional levels of medial branch blocks and RF neurotomy may be necessary. The same indications and limitations apply.

h. Radio Frequency Denervation—Sacroiliac (SI) Joint: This procedure requires neurotomy of multiple nerves, such as L5 dorsal ramus, and/or lateral branches of S1-S3 under C-arm fluoroscopy.

i. Needle Placement: Multi-planar fluoroscopic imaging is required for all steroid injections. Permanent images are suggested to verify needle placement.

ii. Indications: The following three requirements must be fulfilled:

(a). the patient has physical exam findings of at least three positive physical exam maneuvers (e.g., Patrick's sign, Faber's test, Gaenslen distraction or gapping, or compression test). Insufficient functional progress during or after six months of an appropriate program that includes a combination of active therapy, manual therapy, and psychological evaluation and treatment;

(b). at the minimum, manual therapy, performed on a weekly basis per guideline limits by a professional specializing in manual therapy (such as a doctor of osteopathy, physical therapist, or chiropractor) would address any musculoskeletal imbalance causing sacroiliac joint pain such as lumbosacral or sacroiliac dysfunction, pelvic imbalance, or sacral base unleveling<sup>1</sup>. This thorough evaluation would include identification and treatment to resolution of all causal conditions such as iliopsoas, piriformis, gluteal or hamstring tonal imbalance, leg length inequality, loss of motion of the sacrum, lumbar spine or

pelvic bones, and ligamentous, visceral or fascial restrictions; and

(c). an active therapy program would consist of a functionally appropriate rehabilitation program which is advanced in a customized fashion as appropriate commensurate with the patient's level of strength and stability. Such a program would include stretching and strengthening to address areas of muscular imbalance as noted above and neuromuscular re-education to address maintenance of neutral spine via core stabilization with concomitant inhibition of lumbar paravertebral muscles. Patients who demonstrate a directional preference are usually not candidates for this procedure and should receive a trial of directional preference therapy. Patients with confounding findings suggesting zygapophyseal joint or intervertebral disc pain generators should be excluded.

(i). Two fluoroscopically guided blocks of the Sacroiliac joint or appropriate three lateral branches with anesthetics and/or steroid, with relief of pain for the appropriate time periods, and functional improvement must be documented. If the above block provides less than 80 percent but at least 50 percent pain reduction as measured by a numerical pain index scale or documented functional improvement, the sacral peripheral nerve injection or SI joint block should be repeated before a rhizotomy is done. If 50 percent or greater pain reduction is achieved with two sets of blocks (as outlined above) for the SI joint, then rhizotomy may be performed. Pain relief from RF Ablation must last a minimum of six months in order to repeat the RF treatment. There is no need to repeat the SI joint Injection or lateral branch injection after the first RF treatment if the pain that returns is the same as the original pain that required the first RF. It is well known that 67 percent of those with lumbar facet pain also suffer with Sacroiliac joint pain and do also require treatment with SI joint blocks and or SI Joint or Sacral nerve RF Ablation to reach Maximal Medical Improvement. (Implanted Stimulators or Pumps do not usually treat SI joint or facet pain.)

iii. Complications: damage to sacral nerve roots—issues with bladder dysfunction etc. Bleeding, infection, or neural injury. The clinician must be aware of the risk of developing a localized neuritis, or rarely, a deafferentation centralized pain syndrome as a complication of this and other neuroablative procedures.

iv. Post-Procedure Therapy—Active Therapy: implementation of a gentle aerobic reconditioning program (e.g., walking) and back education within the first post-procedure week, barring complications. Instruction and participation in a long-term home-based program of ROM, core strengthening, postural or neuromuscular re-education, endurance, and stability exercises should be accomplished over a period of 4 to 10 visits post-procedure. Patients who are unwilling to engage in this therapy should not receive this procedure.

v. Requirements for Repeat Radiofrequency SI Joint Neurotomy. In some cases, pain may recur. Successful RF neurotomy usually provides from 6 to 18 months of

relief. Repeat neurotomy should only be performed if the initial procedure resulted in improved function for six months. There is no need for repeat Sacroiliac joint or lateral branch injection before RF.

i. Transdiscal Biacuplasty

i. Description: cooled radiofrequency procedure intended to coagulate fissures in the disc and surrounding nerves which could be pain generators.

ii. It is not recommended due to lack of published data demonstrating effectiveness.

j. Trigger Point Injections

i. Description. Trigger point injections are generally accepted treatments. Trigger point treatments can consist of the injection of local anesthetic, with or without corticosteroid, into highly localized, extremely sensitive bands of skeletal muscle fibers. These muscle fibers produce local and referred pain when activated. Medication is injected in a four-quadrant manner in the area of maximum tenderness. Injection can be enhanced if treatments are immediately followed by myofascial therapeutic interventions, such as vapo-coolant spray and stretch, ischemic pressure massage (myotherapy), specific soft tissue mobilization and physical modalities. There is conflicting evidence regarding the benefit of trigger point injections. There is no evidence that injection of medications improves the results of trigger-point injections. Needling alone may account for some of the therapeutic response of injections. Needling must be performed by practitioners with the appropriate credentials in accordance with state and other applicable regulations.

(a). Conscious sedation for patients receiving trigger point injections may be considered. However, the patient must be alert to help identify the site of the injection.

ii. Indications: Trigger point injections may be used to relieve myofascial pain and facilitate active therapy and stretching of the affected areas. They are to be used as an adjunctive treatment in combination with other treatment modalities such as active therapy programs. Trigger point injections should be utilized primarily for the purpose of facilitating functional progress. Patients should continue in an aggressive aerobic and stretching therapeutic exercise program, as tolerated, while undergoing intensive myofascial interventions. Myofascial pain is often associated with other underlying structural problems. Any abnormalities need to be ruled out prior to injection.

iii. Trigger point injections are indicated in patients with consistently observed, well-circumscribed trigger points. This demonstrates a local twitch response, characteristic radiation of pain pattern, and local autonomic reaction such as persistent hyperemia following palpation. Generally, trigger point injections are not necessary unless consistently observed trigger points are not responding to specific, noninvasive, myofascial interventions within approximately a six-week time frame. However, trigger point injections may be occasionally effective when utilized in the patient with immediate, acute onset of pain or in a

post-operative patient with persistent muscle spasm or myofascial pain.

iv. Complications: Potential but rare complications of trigger point injections include infection, pneumothorax, anaphylaxis, penetration of viscera, neurapraxia, and neuropathy. If corticosteroids are injected in addition to local anesthetic, there is a risk of local myopathy. Severe pain on injection suggests the possibility of an intraneural injection, and the needle should be immediately repositioned.

v. Time Frames for Trigger Point Injections

(a). time to produce effect—local anesthetic 30 minutes; 24 to 48 hours for no anesthesia.

(b). frequency—No more than four injection sites per session per week for acute exacerbations only, to avoid significant post-injection soreness.

(c). optimum/maximum duration—four sessions per year. Injections may only be repeated when the above functional and time goals are met.

9. Interdisciplinary rehabilitation programs are the gold standard of treatment for individuals with chronic pain who have not responded to less intensive modes of treatment, except for those determined to be temporarily totally disabled. There is good evidence that interdisciplinary programs that include screening for psychological issues, identification of fear-avoidance beliefs and treatment barriers, and establishment of individual functional and work goals will improve function and decrease disability. There is good evidence that multidisciplinary rehabilitation (physical therapy and either psychological, social, or occupational therapy) shows small effects in reducing pain and improving disability compared to usual care and that multidisciplinary biopsychosocial rehabilitation is more effective than physical treatment for disability improvement after 12 months of treatment in patients with chronic low back pain. Patients with a significant psychosocial impact are most likely to benefit.

a. The International Classification of Functioning, Disability and Health (ICF) model should be considered in patient program planning. The following factors should be addressed: body function and structures, activity expectations, participation barriers, and environmental and personal factors. In general, interdisciplinary programs evaluate and treat multiple and sometimes irreversible conditions, including but not limited to: painful musculoskeletal, neurological, and other chronic painful disorders and psychological issues, drug dependence, abuse, or addiction; high levels of stress and anxiety, failed surgery and pre-existing or latent psychopathology. The number of professions involved on the team in a chronic pain program may vary due to the complexity of the needs of the person served. The OWCA recommends consideration of referral to an interdisciplinary program within six months post-injury in patients with delayed recovery unless surgical interventions or other medical and/or psychological treatment complications intervene.

b. Chronic pain patients need to be treated as outpatients within a continuum of treatment intensity. Outpatient chronic pain programs are available with services provided by a coordinated interdisciplinary team within the same facility (formal) or as coordinated among practices by an authorized treating physician (informal). Formal programs are able to provide coordinated, high intensity level of services and are recommended for most chronic pain patients who have received multiple therapies during acute management.

c. Patients with addiction problems, high-dose opioid use, or abuse of other drugs may require inpatient and/or outpatient chemical dependency treatment programs before or in conjunction with other interdisciplinary rehabilitation. Guidelines from the American Society of Addiction Medicine are available and may be consulted relating to the intensity of services required for different classes of patients in order to achieve successful treatment.

d. Informal interdisciplinary pain programs may be considered for patients who are currently employed, those who cannot attend all-day programs, those with language barriers, or those living in areas not offering formal programs. Before treatment has been initiated, the patient, physician, and insurer should agree on treatment approach, methods, and goals. Generally, the type of outpatient program needed will depend on the degree of impact the pain has had on the patient's medical, physical, psychological, social, and/or vocational functioning.

e. Inpatient pain rehabilitation programs are rarely needed but may be necessary for patients with any of the following conditions: High risk for medical instability; Moderate to severe impairment of physical/functional status; Moderate to severe pain behaviors; Moderate impairment of cognitive and/or emotional status; Dependence on medications from which he or she needs to be withdrawn; and the need for 24-hour supervised nursing and for those temporarily totally disabled. Whether formal or informal, should be comprised of the following dimensions.

i. Communication. To ensure positive functional outcomes, communication between the patient, insurer and all professionals involved must be coordinated and consistent. Any exchange of information must be provided to all parties, including the patient. Care decisions would be communicated to all parties and should include the family and/or support system.

ii. Documentation. Thorough documentation by all professionals involved and/or discussions with the patient. It should be clear that functional goals are being actively pursued and measured on a regular basis to determine their achievement or need for modification. It is advisable to have the patient undergo objective functional measures.

iii. Treatment Modalities. Use of modalities may be necessary early in the process to facilitate compliance with and tolerance to therapeutic exercise, physical conditioning, and increasing functional activities. Active treatments should be emphasized over passive treatments.

Active and self-monitored passive treatments should encourage self-coping skills and management of pain, which can be continued independently at home or at work. Treatments that can foster a sense of dependency by the patient on the caregiver should be avoided. Treatment length should be decided based upon observed functional improvement. For a complete list of Active and Passive Therapies, refer to Therapy - Active, and Therapy - Passive. All treatment timeframes may be extended based upon the patient's positive functional improvement.

iv. Therapeutic Exercise Programs. There is good evidence that exercise alone or as part of a multi-disciplinary program results in decreased disability for workers with non-acute low back pain. There is no sufficient evidence to support the recommendation of any particular exercise regimen over any other exercise regimen. A therapeutic exercise program should be initiated at the start of any treatment rehabilitation. Such programs should emphasize education, independence, and the importance of an on-going exercise regime.

v. Return-to-Work. An authorized treating physician should continually evaluate the patient for their potential to return to work. For patients currently employed, efforts should be aimed at keeping them employed. Formal rehabilitation programs should provide assistance in creating work profiles. For more specific information regarding return-to-work, refer to the Return-to-work section in this guideline.

vi. Patient Education. Patients with pain need to re-establish a healthy balance in lifestyle. All providers should educate patients on how to overcome barriers to resuming daily activity, including pain management, decreased energy levels, financial constraints, decreased physical ability, and change in family dynamics.

vii. Psychosocial Evaluation and Treatment. Psychosocial evaluation should be initiated, if not previously done. Providers of care should have a thorough understanding of the patient's personality profile; especially if dependency issues are involved. Psychosocial treatment may enhance the patient's ability to participate in pain treatment rehabilitation, manage stress, and increase their problem-solving and self-management skills.

viii. Risk Assessments. The following should be incorporated into the overall assessment process, individual program planning, and discharge planning: aberrant medication related behavior, addiction, suicide, and other maladaptive behavior.

ix. Family/Support System Services as Appropriate. The following should be considered in the initial assessment and program planning for the individual: ability and willingness to participate in the plan, coping, expectations, educational needs, insight, interpersonal dynamics, learning style, problem solving, responsibilities, and cultural and financial factors. Support would include counseling, education, assistive technology, and ongoing communication.

x. Discharge Planning. Follow-up visits will be necessary to assure adherence to treatment plan. Programs should have community and/or patient support networks available to patients on discharge.

f. Interdisciplinary programs are characterized by a variety of disciplines that participate in the assessment, planning, and/or implementation of the treatment program. These programs are for patients with greater levels of perceived disability, dysfunction, de-conditioning and psychological involvement. Programs should have sufficient personnel to work with the individual in the following areas: behavioral, functional, medical, cognitive, communication, pain management, physical, psychological, social, spiritual, recreation and leisure, and vocational. Services should address impairments, activity limitations, participation restrictions, environmental needs, and personal preferences of the worker. The following programs are listed in order of decreasing intensity.

i. Formal Interdisciplinary Rehabilitation Programs

(a). Interdisciplinary Pain Rehabilitation. An interdisciplinary pain rehabilitation program provides outcome-focused, coordinated, goal-oriented interdisciplinary team services to measure and improve the functioning of persons with pain and encourage their appropriate use of health care system and services. The program can benefit persons who have limitations that interfere with their physical, psychological, social, and/or vocational functioning. The program shares information about the scope of the services and the outcomes achieved with patients, authorized providers, and insurers.

(i). The interdisciplinary team maintains consistent integration and communication to ensure that all interdisciplinary team members are aware of the plan of care for the patient, are exchanging information, and implement the plan of care. The team members make interdisciplinary team decisions with the patient and then ensure that decisions are communicated to the entire care team.

(ii). Teams that assist in the accomplishment of functional, physical, psychological, social, and vocational goals must include: a medical director, pain team physician(s) who should preferably be board certified in an appropriate specialty, and a pain team psychologist. The medical director of the pain program and each pain team physician should be board certified in pain management or be board certified in his/her specialty area and have completed a one-year fellowship in interdisciplinary pain medicine or palliative care recognized by a national board, or two years of experience in an interdisciplinary pain rehabilitation program, or if less than two years of experience, participate in a mentorship program with an experienced pain team physician. The pain team psychologist should have one year's full-time experience in an interdisciplinary pain program, or if less than two years of experience, participate in a mentorship program with an experienced pain team psychologist. Other disciplines on the team may include, but are not limited to, biofeedback

therapist, occupational therapist, physical therapist, registered nurse (RN), case manager, exercise physiologist, psychiatrist, and/or nutritionist. A recent French interdisciplinary functional spine restoration program demonstrated increased return to work at 12 months:

[a]. time to produce effect: three to four weeks;

[b]. frequency: Full time programs—no less than five hours/day, five days/week; part-time programs—four hours per day, two to three days per week;

[c]. optimum duration: 3 to 12 weeks at least two to three times a week. Follow-up visits weekly or every other week during the first one to two months after the initial program is completed;

[d]. maximum duration: four months for full-time programs and up to six months for part-time programs. Periodic review and monitoring thereafter for one year, and additional follow-up based on the documented maintenance of functional gains.

(b). Occupational Rehabilitation. This is a formal interdisciplinary program addressing a patient's employability and return to work. It includes a progressive increase in the number of hours per day in which a patient completes work simulation tasks until the patient can tolerate a full work day. A full work day is case specific and is defined by the previous employment of the patient. Safe workplace practices and education of the employer and family and/or social support system regarding the person's status should be included. This is accomplished by addressing the medical, psychological, behavioral, physical, functional, and vocational components of employability and return to work.

(i). The following are best practice recommendations for an occupational rehabilitation program:

[a]. work assessments including a work-site evaluation when possible (Refer to Return-To-Work);

[b]. practice of component tasks with modifications as needed;

[c]. development of strength and endurance for work tasks;

[d]. education on safe work practices;

[e]. education of the employer regarding functional implications of the worker when possible;

[f]. involvement of family members and/or support system for the worker;

[g]. promotion of responsibility and self-management;

[h]. assessment of the worker in relationship to productivity, safety, and worker behaviors;

[i]. identification of transferable skills of the worker;



[j]. development of behaviors to improve the ability of the worker to return to work or benefit from other rehabilitation; and

[k]. discharge includes functional/work status, functional abilities as related to available jobs in the community, and a progressive plan for return to work if needed.

(ii). There is some evidence that an integrated care program, consisting of workplace interventions and graded activity teaching that pain need not limit activity, is effective in returning patients with chronic low back pain to work, even with minimal reported reduction of pain. The occupational medicine rehabilitation interdisciplinary team should, at a minimum, be comprised of a qualified medical director who is board certified with documented training in occupational rehabilitation, team physicians having experience in occupational rehabilitation, an occupational therapist, and a physical therapist. As appropriate, the team may also include any of the following: a chiropractor, an RN, a case manager, a psychologist, a vocational specialist, or a certified biofeedback therapist.

(iii). Time frames for occupational rehabilitation:

[a]. time to produce effect: two weeks;

[b]. frequency: two to five visits per week; up to eight hours per day;

[c]. optimum duration: two to four weeks;

[d]. maximum duration: six weeks.

Participation in a program beyond six weeks must be documented with respect to need and the ability to facilitate positive symptomatic and functional gains.

(c). Opioid/Chemical Treatment Programs: Refer to the OWCA's Chronic Pain Disorder Medical Treatment Guideline. Recent programs which incorporate both weaning from opioids and interdisciplinary therapy appear to demonstrate positive long-term results.

ii. Informal Rehabilitation Program. A coordinated interdisciplinary pain rehabilitation program is one in which the authorized treating physician coordinates all aspects of care. This type of program is similar to the formal programs in that it is goal-oriented and provides interdisciplinary rehabilitation services to manage the needs of the patient in the following areas: functional; medical; physical; psychological; social; and vocational.

(a). This program is different from a formal program in that it involves lower frequency and intensity of services/treatment. Informal rehabilitation is geared toward those patients who do not need the intensity of service offered in a formal program or who cannot attend an all-day program due to employment, daycare, language or other barriers.

(b). Patients should be referred to professionals experienced in outpatient treatment of chronic pain. The OWCA recommends the authorized treating physician

consult with physicians experienced in the treatment of chronic pain to develop the plan of care. Communication among care providers regarding clear objective goals and progress toward the goals is essential. Employers should be involved in return to work and work restrictions, and the family and/or social support system should be included in the treatment plan. Professionals from other disciplines likely to be involved include a biofeedback therapist, an occupational therapist, a physical therapist, an RN, a psychologist, a case manager, an exercise physiologist, a psychiatrist, and/or a nutritionist.

(c). Time frames for informal interdisciplinary rehabilitation program:

(i). time to produce effect: three to four weeks;

(ii). frequency: full-time programs—no less than five hours per day, five days per week; part-time programs—four hours per day for two to three days per week;

(iii). optimum duration: 3 to 12 weeks at least two to three times a week. Follow-up visits weekly or every other week during the first one to two months after the initial program is completed;

(iv). maximum duration: four months for full-time programs and up to six months for part-time programs. Periodic review and monitoring thereafter for one year, and additional follow-up based upon the documented maintenance of functional gains.

10. Medications and Medical Management. A thorough medication history, including use of alternative and over the counter medications, should be performed at the time of the initial visit and updated periodically. The medication history may consist of evaluating patient refill records through pharmacies and the Prescription Monitoring Program (PMP) to determine if the patient is receiving their prescribed regimen. Appropriate application of pharmacological agents depends on the patient's age, past history (including history of substance abuse), drug allergies and the nature of all medical problems. It is incumbent upon the healthcare provider to thoroughly understand pharmacological principles when dealing with the different drug families, their respective side effects, drug interactions and primary reason for each medication's usage. Healthcare providers should be aware that Interventional procedures can reduce or stop the need for medications while also improving functional capabilities. Patients should be aware that medications alone are unlikely to provide complete pain relief. In addition to pain relief, a primary goal of drug treatment is to improve the patient's function as measured behaviorally. Besides taking medications, continuing participation in exercise programs and using self-management techniques such as biofeedback, cognitive behavioral therapy, and other individualized physical and psychological practices are required elements for successful chronic pain management. Management must begin with establishing goals and expectations, including shared decision making about risks and benefits of medications.

a. Medication reconciliation is the process of comparing the medications that the patient is currently taking with those for which the patient has orders. This needs to include drug name, dosage, frequency, and route. The reconciliation can assist in avoiding medications errors such as omissions, duplications, dosing errors, or drug interactions. The results can also be used to assist discussion with the patient regarding prescribing or changing medications and the likelihood of side effects, drug interactions, and achieving expected goals. At a minimum, medication reconciliation should be performed for all patients upon the initial visit and whenever refilling or prescribing new medications.

b. Control of chronic non-malignant pain is expected to frequently involve the use of medication. Strategies for pharmacological control of pain cannot be precisely specified in advance. Rather, drug treatment requires close monitoring of the patient's response to therapy, flexibility on the part of the prescriber and a willingness to change treatment when circumstances change. Many of the drugs discussed in the medication section were licensed for indications other than analgesia, but are effective in the control of many types of chronic pain.

c. It is generally wise to begin management with lower cost non-opioid medications whose efficacy equals higher cost medications and medications with a greater safety profile. At practitioner's discretion, decisions to progress to more expensive, non-generic, and/or riskier products are made based on the drug profile, patient feedback, and improvement in function. The provider must carefully balance the untoward side effects of the different drugs with therapeutic benefits, as well as monitor for any drug interactions.

d. All medications should be given an appropriate trial in order to test for therapeutic effect. The length of an appropriate trial varies widely depending on the individual drug. Certain medications may take several months to determine the efficacy, while others require only a few doses. It is recommended that patients with chronic nonmalignant pain be maintained on drugs that have the least serious side effects. For example, patients need to be tried or continued on acetaminophen and/or antidepressant medications whenever feasible as part of their overall treatment for chronic pain. Patients with renal or hepatic disease may need increased dosing intervals with chronic acetaminophen use. Chronic use of NSAIDs is a concern due to increased risk of cardiovascular events and GI bleeding.

e. The use of sedatives and hypnotics is not generally recommended for chronic pain patients. It is strongly recommended that such pharmacological management be monitored or managed by an experienced pain medicine physician, medical psychologist or psychiatrist. Multimodal therapy is the preferred mode of treatment for chronic pain patients whether or not these drugs were used acutely or sub-acutely.

f. Pharmaceutical neuropathic pain studies are limited. Diabetic peripheral neuropathy (DPN) and post-

herpetic neuralgia (PHN) are the two most frequently studied noncancerous neuropathic pain conditions in randomized clinical trials of drug treatment. Some studies enroll only DPN or PHN patients, while other studies may enroll both kinds of patients. There appear to be consistent differences between DPN and PHN with respect to placebo responses, with DPN showing greater placebo response than PHN. Thus, there is an increased likelihood of a "positive" trial result for clinical trials of drug treatment for PHN than for DPN.

g. Although many studies focus on mean change in pain, this may not be the most reliable result. It does not necessarily allow for subgroups that may have improved significantly. Furthermore, the DPN and PHN studies do not represent the type of neurologic pain usually seen in workers' compensation.

h. For these reasons, few pharmaceutical agents listed in this guideline are supported by high levels of evidence, but the paucity of evidence statements should not be construed as meaning that medication is not to be encouraged in managing chronic pain patients.

i. It is advisable to begin with the lowest effective dose proven to be useful for neuropathic pain in the literature. If the patient is tolerating the medication and clinical benefit is appreciated, maximize the dose for that medication or add another second line medication with another mechanism of action. If a medication is not effective, taper off the medication and start another agent. Maintain goal dosing for up to eight weeks before determining its effectiveness. Many patients will utilize several medications from different classes to achieve maximum benefit.

j. The preceding principles do not apply to chronic headache or trigeminal neuralgia patients. These patients should be referred to a physician specializing in the diagnosis and treatment of headache and facial pain.

k. For the clinician to interpret the following material, it should be noted that: drug profiles listed are not complete; dosing of drugs will depend upon the specific drug, especially for off-label use; and not all drugs within each class are listed, and other drugs within the class may be appropriate for individual cases. Clinicians should refer to informational texts or consult a pharmacist before prescribing unfamiliar medications or when there is a concern for drug interactions.

l. The following drug classes are listed in alphabetical order, not in order of suggested use, which is outlined above for neuropathic pain.

i. Alpha-Acting Agents. Noradrenergic pain-modulating systems are present in the central nervous system, and the Alpha-2 adrenergic receptor may be involved in the functioning of these pathways. Alpha-2 agonists may act by stimulating receptors in the substantia gelatinosa of the dorsal horn of the spinal cord, inhibiting the transmission of nociceptive signals. Spasticity may be reduced by presynaptic inhibition of motor neurons. Given

limited experience with their use, they cannot be considered first-line analgesics or second-line analgesics for neurogenic pain, but a trial of their use may be warranted in many cases of refractory pain.

(a). Clonidine (Catapres, Kapvay, Nexiclon):

(i). description—Central Alpha 2 agonist;

(ii). indications—sympathetically mediated pain, treatment of withdrawal from opioids;

[a]. as of the time of this guideline writing, formulations of clonidine have been FDA approved for hypertension;

(iii). major contraindications—severe coronary insufficiency, renal impairment;

(iv). dosing and time to therapeutic effect—increase dosage weekly to therapeutic effect;

(v). major side effects—sedation, orthostatic hypotension, sexual dysfunction, thrombocytopenia, weight gain, agitation, rebound hypertension with cessation;

(vi). drug interactions—beta adrenergics, tricyclic antidepressants;

(vii). laboratory monitoring—renal function, blood pressure.

ii. Anticonvulsants. Although the mechanism of action of anticonvulsant drugs in neuropathic pain states remains to be fully defined, they appear to act as channel blocking agents. A large variety of sodium channels are present in nervous tissue, and some of these are important mediators of nociception, as they are found primarily in unmyelinated fibers and their density increases following nerve injury. While the pharmacodynamic effects of the various anticonvulsant drugs are similar, the pharmacokinetic effects differ significantly. Gabapentin and pregabalin, by contrast, are relatively non-significant enzyme inducers, creating fewer drug interactions. All patients on these medications should be monitored for suicidal ideation. Many of these medications are not recommended for women of child bearing age due to possible teratogenic effects.

(a). Gabapentin and pregabalin are commonly prescribed for neuropathic pain. There is an association between older anticonvulsants including gabapentin and non-traumatic fractures for patients older than 50; this should be taken into account when prescribing these medications.

(b). Gabapentin and pregabalin have indirect (not GABA A or GABA B receptor mediated) GABA-mimetic qualities rather than receptor mediated actions. This can potentially result in euphoria, relaxation, and sedation. It is likely that they also affect the dopaminergic “reward” system related to addictive disorders. Misuse of these medications usually involves doses 3 to 20 times that of the usual therapeutic dose. The medication is commonly used with alcohol or other drugs of abuse. Providers should be aware of the possibility and preferably screen patients for abuse before prescribing these medications. Withdrawal

symptoms, such as insomnia, nausea, headache, or diarrhea, are likely when high doses of pregabalin have been used. Tolerance can also develop.

(c). Gabapentin (Fanatrex, Gabarone, Gralise, Horizant, Neurontin)

(i). Description. Structurally related to gamma-aminobutyric acid (GABA) but does not interact with GABA receptors. Gabapentin affects the alpha-2-delta-1 ligand of voltage gated calcium channels, thus inhibiting neurotransmitter containing intra-cellular vesicles from fusing with the pre-synaptic membranes and reducing primary afferent neuronal release of neurotransmitters (glutamate, CGRP, and substance P). It may also modulate transient receptor potential channels, NMDA receptors, protein kinase C and inflammatory cytokines, as well as possibly stimulating descending norepinephrine mediated pain inhibition.

(ii). Indications. As of the time of this guideline writing, formulations of gabapentin have been FDA approved for post-herpetic neuralgia and partial onset seizures.

[a]. There is strong evidence that gabapentin is more effective than placebo in the relief of painful diabetic neuropathy and post-herpetic neuralgia.

[b]. There is some evidence that gabapentin may benefit some patients with post-traumatic neuropathic pain. There is good evidence that gabapentin is not superior to amitriptyline. There is some evidence that nortriptyline (Aventyl, Pamelor) and gabapentin are equally effective for pain relief of postherpetic neuralgia. There is some evidence that the combination of gabapentin and morphine may allow lower doses with greater analgesic effect than the drugs given separately. There is strong evidence that gabapentin is more effective than placebo for neuropathic pain, even though it provides complete pain relief to a minority of patients. There is some evidence that a combination of gabapentin and nortriptyline provides more effective pain relief than monotherapy with either drug.

(iii).Relative Contraindications—renal insufficiency. Dosage may be adjusted to accommodate renal dysfunction.

(iv).Dosing and Time to Therapeutic Effect. Dosage should be initiated at a low dose in order to avoid somnolence and may require four to eight weeks for titration. Dosage should be adjusted individually. It is taken three to four times per day, and the target dose is 1800 mg.

(v). Major Side Effects—confusion, sedation, dizziness, peripheral edema. Patients should also be monitored for suicidal ideation and drug abuse.

(vi).Drug Interactions—antacids.

(vii). Laboratory Monitoring—renal function.

(d). Pregabalin (Lyrica)

(i). Description: structural derivative of the inhibitory neuro transmitter gamma aminobutyric acid which inhibits calcium influx at the alpha-2-subunit of voltage-gated calcium channels of neurons. By inhibiting calcium influx, there is inhibition of release for excitatory neurotransmitters.

(ii). Indications. As of the time of this guideline writing, pregabalin is FDA approved for the treatment of neuropathic pain, post-herpetic neuralgia, fibromyalgia, diabetic peripheral neuropathy, and partial-onset seizure in adults with epilepsy.

[a]. There is an adequate meta-analysis supporting strong evidence that in the setting of painful diabetic neuropathy, pregabalin as a stand-alone treatment is more effective than placebo in producing a 50 percent pain reduction, but this goal is realized in only 36 percent of patients treated with pregabalin compared with 24 percent of patients treated with placebo. There is an absence of published evidence regarding its effectiveness in improving physical function in this condition. There is also some evidence that pregabalin may be effective in treating neuropathic pain due to spinal cord injury. Unfortunately, most of the studies reviewed used pain as the primary outcome. Only one study considered function and found no improvement.

[b]. When pregabalin is compared with other first line medications for the treatment of neuropathic pain and diabetic peripheral neuropathy, such as amitriptyline and duloxetine, there is good evidence that it is not superior to these medications. Additionally, amitriptyline was found more effective compared to pregabalin for reducing pain scores and disability. Side effects were similar for the two medications. Therefore, amitriptyline is recommended for patients without contraindications, followed by duloxetine or pregabalin. This is based on improved effectiveness in treating neuropathic pain and a favorable side effect profile compared to pregabalin. Pregabalin may be added to amitriptyline therapy.

[c]. Pregabalin seems to be not effective and/or not well tolerated in a large percentage of patients. This is evident in several of the studies using run-in phases, enrichment, and partial enrichment techniques to strengthen the results. This analysis technique excludes placebo responders, non-responders, and adverse events prior to the treatment part of the study. This was done in the large meta-analysis, and one study had 60 percent of participants excluded in the run-in phase.

[d]. Duloxetine, pregabalin, and amitriptyline are approximately of equal benefit with respect to pain relief in the setting of diabetic peripheral neuropathy. There is some evidence that they exert different effects with respect to sleep variables. Total sleep time and REM sleep duration are likely to be greater with pregabalin than with duloxetine or amitriptyline. However, amitriptyline and pregabalin are likely to lead to dizziness and fatigue more frequently than the other drugs, and oxygen desaturation during sleep also appears to be greater with pregabalin.

(iii). Relative Contraindications. Avoid use with hypersensitivity to pregabalin or other similar class of drugs, avoid abrupt withdrawal, avoid use with a CNS depressant or alcohol, and exercise caution when using:

- [a]. in the elderly;
- [b]. with renal impairment;
- [c]. with CHF class III/IV;
- [d]. with a history of angioedema;
- [e]. with depression.

(iv). Dosing and Time to Therapeutic Effect. Pregabalin comes in dosages ranging from 25 mg to 300 mg in 25 mg and 50 mg increments. For neuropathic pain, start at 75 mg twice daily for one week and then increase to 150 mg twice daily for two to three weeks if needed, with a possible final increase to 300 mg twice daily with a max dose of 600 mg/day. The full benefit may be achieved as quickly as 1 week, but it may take six to eight weeks. To discontinue, taper the dose down for at least one week.

(v). Major Side Effects: dizziness (less than 45 percent), somnolence (less than 36 percent), peripheral edema (less than 16 percent), weight gain (less than 16 percent), xerostomia (less than 15 percent), headache (less than 14 percent), fatigue (less than 11 percent), tremor (less than 11 percent), blurred vision/diplopia (less than 12 percent), constipation (less than 10 percent), confusion (less than seven percent), euphoria (less than seven percent), impaired coordination (less than six percent), thrombocytopenia (less than one percent). Patients should be monitored for hypersensitivity reactions, angioedema, suicidality, withdrawal symptoms, and seizures during abrupt discontinuation.

(vi). In regards to euphoria, pregabalin has higher rates compared to gabapentin in patients with history of substance misuse. Thus, prescribers should be aware that there is a potential for misuse.

(vii). Drug Interactions. Avoid use with antiepileptic agents and any CNS depression medications. Specifically avoid use with carbinoxamine, doxylamine, and ginkgo. Monitor closely when pregabalin is use with opioids.

(viii). Laboratory Monitoring: creatinine at baseline.

(e.) Other Anticonvulsants with Limited Third Line Use. It is recommended that a physician experienced in pain management be involved in the care when these medications are used.

(i). Topiramate (Topamax, Topiragen): sulfamate substitute monosacchride. FDA approved for epilepsy or prophylaxis for migraines. Topiramate is without evidence of efficacy in diabetic neuropathic pain, the only neuropathic condition in which it has been adequately tested. The data we have includes the likelihood of major bias due to last observation carried forward imputation, where adverse event withdrawals are much higher with active

treatment than placebo control. Despite the strong potential for bias, no difference in efficacy between topiramate and placebo was apparent. There is good evidence that topiramate demonstrates minimal effect on chronic lumbar radiculopathy or other neuropathic pain. If it is utilized, this would be done as a third or fourth line medication in appropriate patients.

(ii). Lamotrigine (Lamictal). This anti-convulsant drug is not FDA approved for use with neuropathic pain. Due to reported deaths from toxic epidermal necrolysis and Stevens Johnson syndrome, increased suicide risk, and incidents of aseptic meningitis, it is used with caution for patients with seizure or mood disorders. There is insufficient evidence that lamotrigine is effective in treating neuropathic pain and fibromyalgia at doses of about 200 to 400 mg daily. Given the availability of more effective treatments including antiepileptics and antidepressant medicines, lamotrigine does not have a significant place in therapy based on the available evidence. The adverse effect profile of lamotrigine is also of concern. If it is utilized, this would be done as a third or fourth line medication in appropriate patients.

(iii). Zonisamide. There is insufficient evidence that zonisamide provides pain relief in any neuropathic pain condition. There are a number of drug interactions and other issues with its use. If it is utilized, this would be done as a third or fourth line medication in appropriate patients.

(iv). Carbamazepine (Tegretol) has important effects as an inducer of hepatic enzymes and may influence the metabolism of other drugs enough to present problems in patients taking interacting drugs. Dose escalation must be done carefully, since there is good evidence that rapid dose titration produces side-effects greater than the analgesic benefits. Carbamazepine is likely effective in some people with chronic neuropathic pain but with caveats. No trial was longer than four weeks, had good reporting quality, nor used outcomes equivalent to substantial clinical benefit. In these circumstances, caution is needed in interpretation, and meaningful comparison with other interventions is not possible. Carbamazepine is generally not recommended; however, it may be used as a third or fourth line medication. It may be useful for trigeminal neuralgia.

(v). Valproic Acid. There is insufficient evidence to support the use of valproic acid or sodium valproate as a first-line treatment for neuropathic pain. It should be avoided in women of child bearing age. There is more robust evidence of greater efficacy for other medications. However, some guidelines continue to recommend it. If it is utilized, this would be done as a third or fourth line medication in appropriate patients.

(vi). Levetiracetam. There is no evidence that levetiracetam is effective in reducing neuropathic pain. It is associated with an increase in participants who experienced adverse events and who withdrew due to adverse events. Therefore, this is not recommended.

(vii). Lacosamide has limited efficacy in the treatment of peripheral diabetic neuropathy. Higher

doses did not give consistently better efficacy but were associated with significantly more adverse event withdrawals. Where adverse event withdrawals are high with active treatment compared with placebo and when last observation carried forward imputation is used, as in some of these studies, significant overestimation of treatment efficacy can result. It is likely, therefore, that lacosamide is without any useful benefit in treating neuropathic pain; any positive interpretation of the evidence should be made with caution if at all. Therefore, this is not recommended.

iii. Antidepressants are classified into a number of categories based on their chemical structure and their effects on neurotransmitter systems. Their effects on depression are attributed to their actions on disposition of norepinephrine and serotonin at the level of the synapse; although these synaptic actions are immediate, the symptomatic response in depression is delayed by several weeks. When used for chronic pain, the effects may in part arise from treatment of underlying depression, but may also involve additional neuromodulatory effects on endogenous opioid systems, raising pain thresholds at the level of the spinal cord.

(a). Pain responses may occur at lower drug doses with shorter times to symptomatic response than are observed when the same compounds are used in the treatment of mood disorders. Neuropathic pain, diabetic neuropathy, post-herpetic neuralgia, and cancer-related pain may respond to antidepressant doses low enough to avoid adverse effects that often complicate the treatment of depression. First line drugs for neuropathic pain are the tricyclics with the newer formulations having better side effect profiles. SNRIs are considered second line drugs due to their costs and the number needed to treat for a response. Duloxetine may be considered for first line use in a patient who is a candidate for pharmacologic treatment of both chronic pain and depression. SSRIs are used generally for depression rather than neuropathic pain and should not be combined with moderate to high-dose tricyclics.

(b). All patients being considered for antidepressant therapy should be evaluated and continually monitored for suicidal ideation and mood swings.

(i). Tricyclics and Older Agents (e.g., amitriptyline, nortriptyline, doxepin [Silenor, Sinequan, Adapin], desipramine [Norpramin, Pertofrane], imipramine [Tofranil], trazodone [Desyrel, Oleptro])

[a]. Description. Serotonergics, typically tricyclic antidepressants (TCAs), are utilized for their serotonergic properties as increasing CNS serotonergic tone can help decrease pain perception in non-antidepressant dosages. TCAs decrease reabsorption of both serotonin and norepinephrine. They also impact Na channels. Amitriptyline is known for its ability to repair Stage 4 sleep architecture, a frequent problem found in chronic pain patients and to treat depression, frequently associated with chronic pain. However, higher doses may produce more cholinergic side effects than newer tricyclics such as nortriptyline and desipramine. Doxepin and trimipramine also have sedative effects.

[i]. There is some evidence that in the setting of chronic low back pain with or without radiculopathy, amitriptyline is more effective than pregabalin at reducing pain and disability after 14 weeks of treatment. There is some evidence that in the setting of neuropathic pain, a combination of morphine plus nortriptyline produces better pain relief than either monotherapy alone, but morphine monotherapy is not superior to nortriptyline monotherapy, and it is possible that it is actually less effective than nortriptyline. There is insufficient low quality evidence supporting the use of desipramine to treat neuropathic pain. Effective medicines with much greater supportive evidence are available. There may be a role for desipramine in patients who have not obtained pain relief from other treatments. There is no good evidence of a lack of effect; therefore, amitriptyline should continue to be used as part of the treatment of neuropathic pain. Only a minority of people will achieve satisfactory pain relief. Limited information suggests that failure with one antidepressant does not mean failure with all. There is insufficient evidence to support the use of nortriptyline as a first line treatment. However, nortriptyline has a lower incidence of anticholinergic side effects than amitriptyline. It may be considered for patients who are intolerant to the anticholinergic effects of amitriptyline. Effective medicines with greater supportive evidence are available, such as duloxetine and pregabalin.

[ii]. There is some evidence that a combination of some gabapentin and nortriptyline provides more effective pain relief than monotherapy with either drug, without increasing side effects of either drug.

[b]. Indications. Some formulations are FDA approved for depression and anxiety. For the purposes of this guideline, they are recommended for neuropathic pain and insomnia. They are not recommended as a first line drug treatment for depression.

[c]. Major Contraindications: cardiac disease or dysrhythmia, glaucoma, prostatic hypertrophy, seizures, high suicide risk, uncontrolled hypertension and orthostatic hypotension. A screening cardiogram may be done for those 40 years of age or older, especially if higher doses are used. Caution should be utilized in prescribing TCAs. They are not recommended for use in elderly patients 65 years of age or older, particularly if they are at fall risk.

[d]. Dosing and Time to Therapeutic Effect varies by specific tricyclic. Low dosages, less than 100 mg, are commonly used for chronic pain and/or insomnia. Lower doses decrease side effects and cardiovascular risks.

[e]. Major Side Effects. Side effects vary according to the medication used; however, the side effect profile for all of these medications is generally higher in all areas except GI distress, which is more common among the SSRIs and SNRIs. Anticholinergic side effects including, but not limited to, dry mouth, sedation, orthostatic hypotension, cardiac arrhythmia, urinary retention, and weight gain. Dry mouth leads to dental and periodontal conditions (e.g., increased cavities). Patients should also be monitored for suicidal ideation and drug abuse. Anticholinergic side effects

are more common with tertiary amines (amitriptyline, imipramine, doxepin) than with secondary amines (nortriptyline and desipramine).

[f]. Drug Interactions: Tramadol (may cause seizures, both also increase serotonin/norepinephrine, so serotonin syndrome is a concern), clonidine, cimetidine (Tagamet), sympathomimetics, valproic acid (Depakene, Depakote, Epilim, Stavzor), warfarin (Coumadin, Jantoven, Marfarin), carbamazepine, bupropion (Aplezin, Budeprion, Buproban, Forfivo, Wellbutrin, Zyban), anticholinergics, quinolones.

[g]. Recommended Laboratory Monitoring; renal and hepatic function. EKG for those on high dosages or with cardiac risk.

(ii). Selective serotonin reuptake inhibitors (SSRIs) (e.g., citalopram (Celexa), fluoxetine (Prozac, Rapiflux, Sarafem, Selfemra), paroxetine (Paxil, Pexeva), sertraline (Zoloft)) are not recommended for neuropathic pain. They may be used for depression.

(iii). Selective Serotonin Nor-epinephrine Reuptakes Inhibitor (SSNRI)/Serotonin Nor-epinephrine Reuptake Inhibitors (SNRI).

[a]. Description: Venlafaxine (Effexor), desvenlafaxine (Pristiq), duloxetine, and milnacipran (Savella).

[i]. There is strong evidence that duloxetine monotherapy is more effective than placebo in relieving the pain of diabetic peripheral neuropathy; however, monotherapy leads to a 50 percent pain reduction in only half of patients who receive a therapeutic dose.

[ii]. AHRQ supports the use of duloxetine for chronic low back pain.

[iii] There is good evidence that in patients with painful diabetic neuropathy who have not had good responses to monotherapy with 60 mg of duloxetine or 300 mg of pregabalin, a clinically important benefit can be achieved by either of two strategies: doubling the dose of either drug, or combining both drugs at the same dose. It is likely that the strategy of combining the two drugs at doses of 60 and 300 mg respectively is more beneficial overall.

[iv]. There was no evidence to support the use of milnacipran to treat neuropathic pain conditions, although it is used for fibromyalgia. It is not generally recommended but may be used if patients cannot tolerate other medications.

[v]. There is insufficient evidence to support the use of venlafaxine in neuropathic pain. However, it may be useful for some patients who fail initial recommended treatments. Venlafaxine is generally reasonably well tolerated, but it can precipitate fatigue, somnolence, nausea, and dizziness in a minority of people. The sustained release formulations are generally more tolerable as inter-dose withdrawal symptoms can be avoided. They should be trialed if the patient cannot tolerate the immediate release formulation.

[b]. Indications. At the time of writing this guideline, duloxetine has been FDA approved for treatment of diabetic neuropathic pain and chronic musculoskeletal pain. Therefore, best evidence supports the use of duloxetine alone or with pregabalin.

[c]. Relative Contraindications: seizures, eating disorders.

[d]. Major side effects depends on the drug, but commonly includes dry mouth, nausea, fatigue, constipation, and abnormal bleeding. Serotonin syndrome is also a risk. Gastrointestinal (GI) distress, drowsiness, sexual dysfunction less than other classes. Hypertension and glaucoma with venlafaxine. Cardiac issues with venlafaxine and withdrawal symptoms unless tapered. Studies show increased suicidal ideation and attempts in adolescents and young adults. Patients should also be monitored for suicidal ideation and drug abuse.

[e]. Drug Interactions: drug specific.

[f]. Laboratory Monitoring: renal and hepatic monitoring, venlafaxine may cause cholesterol or triglyceride increases.

(iv). Atypical antidepressants/other agents may be used for depression; however, are not appropriate for neuropathic pain.

iv. Cannabinoid Products. At the time of writing, marijuana use is illegal under federal law and cannot be recommended for use in this guideline.

v. Nonsteroidal Anti-Inflammatory Drugs (NSAIDs). NSAIDs are useful for pain and inflammation. In mild cases, they may be the only drugs required for analgesia. There are several classes of NSAIDs. The response of the individual injured worker to a specific medication is unpredictable. For this reason, a range of NSAIDs may be tried in each case, with the most effective preparation being continued. Patients should be closely monitored for adverse reactions. The FDA advises that many NSAIDs may cause an increased risk of serious cardiovascular thrombotic events, myocardial infarction, and stroke, which can be fatal. Administration of proton pump inhibitors, Histamine 2 Blockers, or prostaglandin analog misoprostol along with these NSAIDs may reduce the risk of duodenal and gastric ulceration in patients at higher risk for this adverse event (e.g., age > 60, concurrent antiplatelet or corticosteroid therapy). They do not impact possible cardiovascular complications. Due to the cross-reactivity between aspirin and NSAIDs, NSAIDs should not be used in aspirin-sensitive patients, and they should be used with caution in all asthma patients. NSAIDs are associated with abnormal renal function, including renal failure, as well as abnormal liver function. Patients with renal or hepatic disease may need increased dosing intervals with chronic use. Chronic use of NSAIDs is generally not recommended due to increased risk of cardiovascular events and GI bleeding.

(a). Topical NSAIDs may be more appropriate for some patients as there is some evidence that topical

NSAIDs are associated with fewer systemic adverse events than oral NSAIDs.

(b). NSAIDs may be associated with non-unions. Thus, their use with fractures is questionable.

(c). Certain NSAIDs may have interactions with various other medications. Individuals may have adverse events not listed above. Intervals for metabolic screening are dependent on the patient's age and general health status and should be within parameters listed for each specific medication. Complete Blood Count (CBC) and liver and renal function should be monitored at least every six months in patients on chronic NSAIDs and initially when indicated.

(d). There is no evidence to support or refute the use of oral NSAIDs to treat neuropathic pain conditions.

(e). AHRQ supports the use of NSAIDs for chronic low back pain.

(i). Non-selective non-steroidal anti-inflammatory drugs includes NSAIDs and acetylsalicylic acid. Serious GI toxicity, such as bleeding, perforation, and ulceration can occur at any time, with or without warning symptoms, in patients treated with traditional NSAIDs. Physicians should inform patients about the signs and/or symptoms of serious GI toxicity and what steps to take if they occur. Anaphylactoid reactions may occur in patients taking NSAIDs. NSAIDs may interfere with platelet function. Fluid retention and edema have been observed in some patients taking NSAIDs.

[a]. Time frames for non-selective non-steroidal anti-inflammatory drugs:

[i]. optimum duration: one week;

[ii]. maximum continuous duration (not interment): one year. Use of these substances long-term (three days per week or greater) is associated with rebound pain upon cessation.

(ii). Selective Cyclo-oxygenase-2 (COX-2) Inhibitors. COX-2 inhibitors differ from the traditional NSAIDs in adverse side effect profiles. The major advantages of selective COX-2 inhibitors over traditional NSAIDs are that they have less GI toxicity and no platelet effects. COX-2 inhibitors can worsen renal function in patients with renal insufficiency; thus, renal function may need monitoring.

[a]. There is good evidence that celecoxib (Celebrex) in a dose of 200 mg per day, administered over a long period, does not have a worse cardiovascular risk profile than naproxen at a dose of up to 1000 mg per day or ibuprofen at a dose of up to 2400 mg per day. There is good evidence that celecoxib has a more favorable safety profile than ibuprofen or naproxen with respect to serious GI adverse events, and it has a more favorable safety profile than ibuprofen with respect to renal adverse events. There is an absence of evidence concerning the relative safety of celecoxib at doses greater than 200 mg per day.

[b]. COX-2 inhibitors should not be first-line for low risk patients who will be using an NSAID short-term. COX-2 inhibitors are indicated in select patients who do not tolerate traditional NSAIDs. Serious upper GI adverse events can occur even in asymptomatic patients. Patients at high risk for GI bleed include those who use alcohol, smoke, are older than 65 years of age, take corticosteroids or anti-coagulants, or have a longer duration of therapy. Celecoxib is contraindicated in sulfonamide allergic patients.

[c]. Time frames for selective cyclooxygenase-2 (COX-2) inhibitors:

[i]. optimum duration: 7 to 10 days;

[ii]. maximum duration: Chronic use is appropriate in individual cases. Use of these substances long-term (three days per week or greater) is associated with rebound pain upon cessation.

vi. Opioids. Opioids are the most powerful analgesics. Their use in acute pain and moderate-to-severe cancer pain is well accepted. Their use in chronic nonmalignant pain, however, is fraught with controversy and lack of scientific research. Deaths in the United States from opioids have escalated in the last 15 years. The CDC states the following in their 2016 Primary Care guideline for prescribing opioids. Opioid pain medication use presents serious risk, including overdose and opioid use disorder. From 1999 to 2014, more than 165,000 persons died from overdose related to opioid pain medication in the United States. In the past decade, while the death rates for the top leading causes of death such as heart disease and cancer have decreased substantially, the death rate associated with opioid pain medication has increased markedly. Sales of opioid pain medication have increased in parallel with opioid-related overdose deaths. The Drug Abuse Warning Network estimated that less than 420,000 emergency department visits were related to the misuse or abuse of narcotic pain relievers in 2011, the most recent year for which data are available. Opioid poisoning has also been identified in work-related populations.

(a). Effectiveness and Side Effects. Opioids include some of the oldest and most effective drugs used in the control of severe pain. The discovery of opioid receptors and their endogenous peptide ligands has led to an understanding of effects at the binding sites of these naturally occurring substances. Most of their analgesic effects have been attributed to their modification of activity in pain pathways within the central nervous system; however, it has become evident that they also are active in the peripheral nervous system. Activation of receptors on the peripheral terminals of primary afferent nerves can mediate anti-nociceptive effects, including inhibition of neuronal excitability and release of inflammatory peptides. Some of their undesirable effects on inhibiting gastrointestinal motility are peripherally mediated by receptors in the bowel wall.

(i). Most studies show that only around 50 percent of patients tolerate opioid side effects and receive an acceptable level of pain relief. Depending on the diagnosis

and other agents available for treatment, the incremental benefit can be small.

(ii). There is strong evidence that in the setting of chronic nonspecific low back pain, the short and intermediate term reduction in pain intensity of opioids, compared with placebo, falls short of a clinically important level of effectiveness. There is an absence of evidence that opioids have any beneficial effects on function or reduction of disability in the setting of chronic nonspecific low back pain. AHRQ found that opioids are effective for treating chronic low back pain. However, the report noted no evidence regarding the long-term effectiveness or safety for chronic opioids.

(iii). There is good evidence that opioids are more efficient than placebo in reducing neuropathic pain by clinically significant amounts. There is a lack of evidence that opioids improve function and quality of life more effectively than placebo. There is good evidence that opioids produce significantly more adverse effects than placebo such as constipation, drowsiness, dizziness, nausea, and vomiting. There is a lack of evidence that they are superior to gabapentin or nortriptyline for neuropathic pain reduction.

(iv). Patients should have a thorough understanding of the need to pursue many other pain management techniques in addition to medication use in order to function with chronic pain. They should also be thoroughly aware of the side effects and how to manage them. There is strong evidence that adverse events such as constipation, dizziness, and drowsiness are more frequent with opioids than with placebo. Common side effects are drowsiness, constipation, nausea, and possible testosterone decrease with longer term use.

(v). There is some evidence that in the setting of chronic low back pain with disc pathology, a high degree of anxiety or depressive symptomatology is associated with relatively less pain relief in spite of higher opioid dosage than when these symptoms are absent. A study comparing Arkansas Medicaid and a national commercial insurance population found that the top five percent of opioid users accounted for 48 to 70 percent of total opioid use. Utilization was increased among those with mental health and substance use disorders and those with multiple pain conditions. Psychological issues should always be screened for and treated in chronic pain patients. Therefore, for the majority of chronic pain patients, chronic opioids are unlikely to provide meaningful increase in function in daily activities. However, a subpopulation of patients may benefit from chronic opioids when properly prescribed and all requirements from medical management are followed.

(b). Hyperalgesia. Administration of opioid analgesics leads not only to analgesia, but may also lead to a paradoxical sensitization to noxious stimuli. Opioid induced hyperalgesia has been demonstrated in animals and humans using electrical or mechanical pain stimuli. This increased sensitivity to mildly painful stimuli does not occur in all patients and appears to be less likely in those with cancer, clear inflammatory pathology, or clear neuropathic pain.



When hyperalgesia is suspected, opioid tapering is appropriate.

(c). Opioid Induced Constipation (OIC). Some level of constipation is likely ubiquitous among chronic opioid users. An observational study of chronic opioid users who also used some type of laxative at least four times per week noted that approximately 50 percent of the patients were dissatisfied and they continue to report stool symptoms. 71 percent used a combination of natural and dietary treatment, 64.3 percent used over-the-counter laxatives, and 30 percent used prescription laxatives. Other studies report similar percentages. There are insufficient quality studies to recommend one specific type of laxative over others.

(i). The easiest method for identifying constipation, which is also recommended by a consensus, multidisciplinary group, is the Bowel Function Index. It assesses the patient's impression over the last seven days for ease of defecation, feeling of incomplete bowel evacuation, and personal judgment re-constipation.

(ii). Stepwise treatment for OIC is recommended, and all patients on chronic opioids should receive information on treatment for constipation. Dietary changes increasing soluble fibers are less likely to decrease OIC and may cause further problems if GI motility is decreased. Stool softeners may be tried, but stimulant and osmotic laxatives are likely to be more successful. Osmotic laxatives include lactulose and polyethylene glycol. Stimulants include bisacodyl, sennosides, and sodium picosulfate, although there may be some concern regarding use of stimulants on a regular basis.

(iii). Opioid rotation or change in opioids may be helpful for some patients. It is possible that sustained release opioid products cause more constipation than short acting agents due to their prolonged effect on the bowel opioid receptors. Tapentadol is a u-opioid agonist and norepinephrine reuptake inhibitor. It is expected to cause less bowel impairment than oxycodone or other traditional opioids. Tapentadol may be the preferred opioid choice for patients with OIC.

(iv). Other prescription medications may be used if constipation cannot adequately be controlled with the previous measures. Naloxegol is a pegylated naloxone molecule that does not pass the blood brain barrier and thus can be given with opioid therapy. There is good evidence that it can alleviate OIC and that 12.5 mg starting dose has an acceptable side effect profile.

(v). Methylnaltrexone does not cross the blood brain barrier and can be given subcutaneously or orally. It is specifically recommended for opioid induced constipation for patients with chronic non-cancer pain.

(vi). Misoprostol is a synthetic prostaglandin E1 agonist and has the side effect of diarrhea in some patients. It also has been tried for opioid induced constipation, although it is not FDA approved for this use.

(vii). Naldemedine is an opioid antagonist indicated for the treatment of opioid induced constipation in adult patients with chronic pain.

(viii). Lubiprostone is a prostaglandin E1 approved for use in opioid constipation.

(ix). Most patients will require some therapeutic control for their constipation. The stepwise treatment discussed should be followed initially. If that has failed and the patient continues to have recurrent problems with experiencing severe straining, hard or lumpy stool with incomplete evacuation, or infrequent stools for 25 percent of the time despite the more conservative measures, it may be appropriate to use a pharmaceutical agent.

(d). Physiologic Responses to Opioids. Physiologic responses to opioids are influenced by variations in genes which code for opiate receptors, cytochrome P450 enzymes, and catecholamine metabolism. Interactions between these gene products significantly affect opiate absorption, distribution, and excretion. Hydromorphone, oxycodone, and morphine are metabolized through the glucuronide system. Other opioids generally use the cytochrome P450 system. Allelic variants in the mu opiate receptor may cause increased analgesic responsiveness to lower drug doses in some patients. The genetic type can predict either lower or higher needs for opioids. For example, at least 10 percent of Caucasians lack the CYP450 2D6 enzyme that converts codeine to morphine. In some cases, genetic testing for cytochrome P450 type may be helpful. When switching patients from codeine to other medications, assume the patient has little or no tolerance to opioids. Many gene-drug associations are poorly understood and of uncertain clinical significance. The treating physician needs to be aware of the fact that the patient's genetic makeup may influence both the therapeutic response to drugs and the occurrence of adverse effects. A Comprehensive genetic testing panel may be ordered by treating physician for these multiple P450 genes once in a lifetime and utilized whenever there is a question of metabolism or unusual response of any drugs used to treat pain conditions, because multiple drugs and associated genes can cause problems with opioid metabolism.

(e). Adverse Events. Physicians should be aware that deaths from unintentional drug overdoses exceed the number of deaths from motor vehicle accidents in the US. Most of these deaths are due to the use of opioids, usually in combination with other respiratory depressants such as alcohol or benzodiazepines. The risk for out of hospital deaths not involving suicide was also high. The prevalence of drug abuse in the population of patients undergoing pain management varies according to region and other issues. One study indicated that one-fourth of patients being monitored for chronic opioid use have abused drugs occasionally, and one-half of those have frequent episodes of drug abuse. 80 percent of patients admitted to a large addiction program reported that their first use of opioids was from prescribed medication.

(i). There is good evidence that in generally healthy patients with chronic musculoskeletal pain, treatment with long-acting opioids, compared to treatments with anticonvulsants or antidepressants, is associated with an increased risk of death of approximately 69 percent, most of which arises from non-overdose causes, principally cardiovascular in nature. The excess cardiovascular mortality principally occurs in the first 180 days from starting opioid treatment.

(ii). There is some evidence that compared to an opioid dose under 20 MED per day, a dose of 20-50 mg nearly doubles the risk of death, a dose of 50 to 100 mg may increase the risk more than fourfold, and a dose greater than 100 mg per day may increase the risk as much as sevenfold. However, the absolute risk of fatal overdose in chronic pain patients is fairly low and may be as low as 0.04 percent. There is good evidence that prescription opioids in excess of 200 MED average daily doses are associated with a near tripling of the risk of opioid-related death, compared to average daily doses of 20 MED. Average daily doses of 100-200 mg and doses of 50-99 mg per day may be associated with a doubling of mortality risk, but these risk estimates need to be replicated with larger studies.

(iii). Doses of opioids in excess of 120 MED have been observed to be associated with increased duration of disability, even when adjusted for injury severity in injured workers with acute low back pain. Higher doses are more likely to be associated with hypo-gonadism, and the patient should be informed of this risk. Higher doses of opioids also appear to contribute to the euphoric effect. The CDC recommends Primary Care Practitioners limiting to 90 MED per day to avoid increasing risk of overdose or referral to a pain specialist.

(iv). In summary, there is strong evidence that any dose above 50 MED per day is associated with a higher risk of death and 100 mg or greater appears to significantly increase the risk. Interventional techniques such as Spinal Cord Stimulation or Intrathecal Catheters and Programmable pumps should be considered in order to stop oral opioids usage.

(v). Workers who eventually are diagnosed with opioid abuse after an injury are also more likely to have higher claims cost. A retrospective observational cohort study of workers' compensation and short-term disability cases found that those with at least one diagnosis of opioid abuse cost significantly more in days lost from work for both groups and in overall healthcare costs for the short-term disability groups. About 0.5 percent of eligible workers were diagnosed with opioid abuse.

(f). Dependence versus Addiction. The central nervous system actions of these drugs account for much of their analgesic effect and for many of their other actions, such as respiratory depression, drowsiness, mental clouding, reward effects, and habit formation. With respect to the latter, it is crucial to distinguish between two distinct phenomena: dependence and addiction.

(i). Dependence is a physiological tolerance and refers to a set of disturbances in body homeostasis that leads to withdrawal symptoms, which can be produced with abrupt discontinuation, rapid reduction, decreasing blood levels, and/or by administration of an antagonist.

(ii). Addiction is a primary, chronic, neurobiological disease, with genetic, psychological, and environmental factors influencing its development and manifestations. It is a behavioral pattern of drug craving and seeking which leads to a preoccupation with drug procurement and an aberrant pattern of use. The drug use is frequently associated with negative consequences.

(iii). Dependence is a physiological phenomenon, which is expected with the continued administration of opioids, and need not deter physicians from their appropriate use. Before increasing the opioid dose, the physician should review other possible causes for the decline in analgesic effect. Increasing the dose may not result in improved function or decreased pain. Remember that it is recommended for total morphine milligram equivalents (MME) per day to remain at 50 or below. Consideration should be given to possible new psychological stressors or an increase in the activity of the nociceptive pathways. Other possibilities include new pathology, low testosterone level that impedes delivery of opioids to the central nervous system, drug diversion, hyperalgesia, or abusive use of the medication.

(g). Choice of Opioids. No long-term studies establish the efficacy of opioids over one year of use or superior performance by one type. There is no evidence that one long-acting opioid is more effective than another, or more effective than other types of medications, in improving function or pain. There is some evidence that long-acting oxycodone (Dazidox, Endocodone, ETH-oxycodone, Oxycontin, Oxyfast, OxyIR, Percolone, Roxycodone) and oxymorphone have equal analgesic effects and side effects, although the milligram dose of oxymorphone (Opana) is one-half that of oxycodone. There is no evidence that long-acting opioids are superior to short-acting opioids for improving function or pain or causing less addiction. A number of studies have been done assessing relief of pain in cancer patients. A recent systematic review concludes that oxycodone does not result in better pain relief than other strong opioids including morphine and oxymorphone. It also found no difference between controlled release and immediate release oxycodone. There is some evidence that extended release hydrocodone has a small and clinically unimportant advantage over placebo for relief of chronic low back pain among patients who are able to tolerate the drug and that 40 percent of patients who begin taking the drug do not attain a dose which provides pain relief without unacceptable adverse effects. Hydrocodone ER does not appear to improve function in comparison with placebo. A Cochrane review of oxycodone in cancer pain also found no evidence in favor of the longer acting opioid. There does not appear to be any significant difference in efficacy between once daily hydromorphone and sustained release oxycodone. Nausea and constipation are common for both medications

between 26 to 32 percent. November 21, 2017, the FDA Commissioner, Scott Gottlieb, M.D., issued a Statement to promote development of generic versions of opioids formulated to deter abuse. One year earlier the FDA issued a statement encouraging development of Abuse Deterrent Formulations for opioids as a meaningful health benefit designed to reduce opioid abuse in the U.S. and to potentially and eventually remove conventional non deterrent opioids from the market if found to be unsafe.

(i). There is some evidence that in the setting of neuropathic pain, a combination of morphine plus nortriptyline produces better pain relief than either monotherapy alone, but morphine monotherapy is not superior to nortriptyline monotherapy, and it is possible that it is actually less effective than nortriptyline.

(ii). Long-acting opioids should not be used for the treatment of acute, sub-acute, or post-operative pain, as this is likely to lead to drug dependence and difficulty tapering the medication. Additionally, there is a potential for respiratory depression to occur. The FDA requires that manufacturers develop Risk Evaluation and Mitigation Strategies (REMS) for most opioids. Physicians should carefully review the plans or educational materials provided under this program. Clinical considerations should determine the need for long-acting opioids given their lack of evidence noted above.

(iii). Addiction and abuse potentials of commonly prescribed opioid drugs may be estimated in a variety of ways, and their relative ranking may depend on the measure which is used. One systematic study of prescribed opioids estimated rates of drug misuse were estimated at 21 to 29 percent and addiction at 8 to 12 percent. There is good evidence that in the setting of new onset chronic non-cancer pain, there is a clinically important relationship between opioid prescription and subsequent opioid use disorder. Compared to no opioid use, short-term opioid use approximately triples the risk of opioid use disorder in the next 18 months. Use of opioids for over 90 days is associated with very pronounced increased risks of the subsequent development of an opioid use disorder, which may be as much as one hundredfold when doses greater than 120 MED are taken for more than 90 days. The absolute risk of these disorders is very uncertain but is likely to be greater than 6.1 percent for long duration treatment with a high opioid dose. Pain physicians should be consulted when the MED reaches 100 to develop an updated treatment plan.

(iv). Hydrocodone is the most commonly prescribed opioid in the general population and is one of the most commonly abused opioids in the population. However, the abuse rate per 1000 prescriptions is lower than the corresponding rates for extended release oxycodone, hydromorphone (Dilaudid, Palladone), and methadone. Extended release oxycodone appears to be the most commonly abused opioid, both in the general population and in the abuse rate per 1000 prescriptions. Tramadol, by contrast, appears to have a lower abuse rate than for other opioids.

(v). Types of opioids are listed below.

[a]. Buprenorphine (various formulations) is prescribed as an intravenous injection, transdermal patch, buccal film, or sublingual tablet due to lack of bioavailability of oral agents. Depending upon the formulation, buprenorphine may be indicated for the treatment of pain or for the treatment of opioid dependence (addiction).

[i]. Buprenorphine for Opioid Dependence (addiction). FDA has approved a number of buccal films including those with naloxone and a sublingual tablet to treat opioid dependence (addiction).

[ii]. Buprenorphine for Pain. The FDA has approved specific forms of an intravenous and subcutaneous injectable, transdermal patch, and a buprenorphine buccal film to treat pain. However, by law, the transdermal patch and the injectable forms cannot be used to treat opioid dependence (addiction), even by DATA-2000 waived physicians authorized to prescribe buprenorphine for addiction. Transdermal forms may cause significant skin reaction. Buprenorphine is not recommended for most chronic pain patients due to methods of administration, reports of euphoria in some patients, and lack of proof for improved efficacy in comparison with other opioids. 1

[iii]. There is insufficient evidence to support or refute the suggestion that buprenorphine has any efficacy in any neuropathic pain condition.

[iv]. There is good evidence transdermal buprenorphine is not inferior to oral tramadol in the treatment of moderate to severe musculoskeletal pain arising from conditions like osteoarthritis and low back pain. The population of patients for whom it is more appropriate than tramadol is not established but would need to be determined on an individual patient basis if there are clear reasons not to use oral tramadol.

[v]. In a well done study, 63 percent of those on buccal buprenorphine achieved a 30 percent or more decrease in pain at 12 weeks compared to a 47 percent placebo response. Approximately 40 percent of the initial groups eligible for the study dropped out during the initial phase when all patients received the drug to test for incompatibility.

[vi]. There is strong evidence that in patients being treated with opioid agonists for heroin addiction, methadone is more successful than buprenorphine at retaining patients in treatment. The rates of opiate use, as evidenced by positive urines, are equivalent between methadone and buprenorphine. There is strong evidence that buprenorphine is superior to placebo with respect to retention in treatment, and good evidence that buprenorphine is superior to placebo with respect to positive urine testing for opiates.

[vii]. There is an adequate meta-analysis supporting good evidence that transdermal fentanyl and transdermal buprenorphine are similar with respect to

analgesia and sleep quality, and they are similar with respect to some common adverse effects such as constipation and discontinuation due to lack of effect. However, buprenorphine probably causes significantly less nausea than fentanyl, and it probably carries a lower risk of treatment discontinuation due to adverse events. It is also likely that both transdermal medications cause less constipation than oral morphine.

[viii]. Overall, due to cost and lack of superiority, buprenorphine is not a front line opioid choice. However, it may be used in those with a history of addiction or at high risk for addiction who otherwise qualify for chronic opioid use. It is also appropriate to consider buprenorphine products for tapering strategies and those on high dose morphine of 90 MED or more.

[b]. Codeine with Acetaminophen. Some patients cannot genetically metabolize codeine and therefore have no response. Codeine is not generally used on a daily basis for chronic pain. Acetaminophen dose per day should be limited to 2 grams.

[c]. Fentanyl (Actiq, Duragesic, Fentora, Sublimazem, Subsys) is not recommended for use with musculoskeletal chronic pain patients. It has been associated with a number of deaths and has high addiction potential. Fentanyl should never be used transbuccally in this population. If Fentanyl it is being considered for a very specific patient population, it requires support from a pain specialist. Subsys is only indicated for Cancer Pain.

[d]. Meperidine (Demerol) is not recommended for chronic pain. It and its active metabolite, normeperidine, present a serious risk of seizure and hallucinations. It is not a preferred medication for acute pain as its analgesic effect is similar to codeine.

[e]. Methadone requires special precautions given its unpredictably long half-life and non-linear conversion from other opioids such as morphine. It may also cause cardiac arrhythmias due to QT prolongation and has been linked with a greater number of deaths due to its prolonged half-life. No conclusions can be made regarding differences in efficacy or safety between methadone and placebo, other opioids, or other treatments. There is strong evidence that in patients being treated with opioid agonists for heroin addiction, methadone is more successful than buprenorphine at retaining patients in treatment. The rates of opiate use, as evidenced by positive urines, are equivalent between methadone and buprenorphine. Methadone should only be prescribed by those with experience in managing this medication. Conversion from another opioid to methadone (or the other way around) can be very challenging, and dosing titration must be done very slowly (no more than every seven days). Unlike many other opioids, it should not be used on an "as needed" basis, as decreased respiratory drive may occur before the full analgesic effect of methadone is appreciated. If methadone is being considered, genetic screening is appropriate. CYP2B6 polymorphism appears to metabolize methadone more

slowly than the usual population and may cause more frequent deaths.

[f]. Morphine may be used in the non-cancer pain population. A study in chronic low back pain suggested that individuals with a greater amount of endogenous opioids will have a lower pain relief response to morphine.

[g]. Oxycodone and Hydromorphone. There is no evidence that oxycodone (as oxycodone CR) is of value in treating people with painful diabetic neuropathy, postherpetic neuralgia, or other neuropathic conditions. There was insufficient evidence to support or refute the suggestion that hydromorphone has any efficacy in any neuropathic pain condition. Oxycodone was not associated with greater pain relief in cancer patients when compared to morphine or oxymorphone.

[h]. Propoxyphene (Darvon, Davon-N, PP-Cap) has been withdrawn from the market due to cardiac effects including arrhythmias.

[i]. Tapentadol (Nucynta) is a mu opioid agonist which also inhibits serotonin and norepinephrine reuptake activity. It is currently available in an intermediate release formulation and may be available as extended release if FDA approved. Due to its dual activity, it can cause seizures or serotonin syndrome, particularly when taken with other SSRIs, SNRIs, tricyclics, or MAO inhibitors. It has not been tested in patients with severe renal or hepatic damage. It has similar opioid abuse issues as other opioid medication; however, it is promoted as having fewer GI side effects, such as constipation. There is good evidence that extended release tapentadol is more effective than placebo and comparable to oxycodone. In that study, the percent of patients who achieved 50 percent or greater pain relief was: placebo, 18.9 percent, tapentadol, 27.0 percent, and oxycodone, 23.3 percent. There is some evidence that tapentadol can reduce pain to a moderate degree in diabetic neuropathy, average difference 1.4/10 pain scale, with tolerable adverse effects. However, a high quality systematic review found inadequate evidence to support tapentadol to treat chronic pain. Tapentadol is not recommended as a first line opioid for chronic, subacute, or acute pain due to the cost and lack of superiority over other analgesics. There is some evidence that tapentadol causes less constipation than oxycodone. Therefore, it may be appropriate for patients who cannot tolerate other opioids due to GI side effects.

[j]. Tramadol (Rybix, Ryzolt, Ultram)

[i]. Description: an opioid partial agonist that does not cause GI ulceration or exacerbate hypertension or congestive heart failure. It also inhibits the reuptake of norepinephrine and serotonin which may contribute to its pain relief mechanism. There are side effects similar to opioid side effects and may limit its use. They include nausea, sedation, and dry mouth. 1

[ii]. Indications: mild to moderate pain relief. As of the time of this guideline writing, formulations of tramadol have been FDA approved for management of

moderate to moderately severe pain in adults. This drug has been shown to provide pain relief equivalent to that of commonly prescribed NSAIDs. Unlike other pure opioid agonists, there is a ceiling dose to tramadol due to its serotonin activity (usually 300-400 mg per day). There is some evidence that it alleviates neuropathic pain following spinal cord injury. There is inadequate evidence that extended-release tramadol/acetaminophen in a fixed-dose combination of 75mg/650 mg is more effective than placebo in relieving chronic low back pain; it is not more effective in improving function compared to placebo. There is some evidence that tramadol yields a short-term analgesic response of little clinical importance relative to placebo in post-herpetic neuralgia which has been symptomatic for approximately six months. However, given the effectiveness of other drug classes for neuropathic pain, tramadol should not be considered a first line medication. It may be useful for patients who cannot tolerate tricyclic antidepressants or other medications.

[iii]. Contraindications. Use cautiously in patients who have a history of seizures, who are taking medication that may lower the seizure threshold, or taking medications that impact serotonin reuptake and could increase the risk for serotonin syndrome, such as monoamine oxidase inhibitors (MAO) inhibitors, SSRIs, TCAs, and alcohol. Use with caution in patients taking other potential QT prolonging agents. Not recommended in those with prior opioid addiction. Has been associated with deaths in those with an emotional disturbance or concurrent use of alcohol or other opioids. Significant renal and hepatic dysfunction requires dosage adjustment.

[iv]. Side Effects. May cause impaired alertness or nausea. This medication has physically addictive properties, and withdrawal may follow abrupt discontinuation.

[v]. Drug Interactions: opioids, sedating medications, any drug that affects serotonin and/or norepinephrine (e.g., SNRIs, SSRIs, MAOs, and TCAs).

[vi]. Laboratory Monitoring: renal and hepatic function.

(vi). Health care professionals and their patients must be particularly conscientious regarding the potential dangers of combining over-the-counter acetaminophen with prescription medications that also contain acetaminophen. Opioid and acetaminophen combination medication are limited due to the acetaminophen component. Total acetaminophen dose per day should not exceed 4 grams per any 24-hour period and is preferably limited to 2 grams per day to avoid possible liver damage.

(vii). Indications. The use of opioids is well accepted in treating cancer pain, where nociceptive mechanisms are generally present due to ongoing tissue destruction, expected survival may be short, and symptomatic relief is emphasized more than functional outcomes. In chronic non-malignant pain, by contrast, tissue destruction has generally ceased, meaning that central and

neuropathic mechanisms frequently overshadow nociceptive processes. Expected survival in chronic pain is relatively long, and return to a high-level of function is a major goal of treatment. Therefore, approaches to pain developed in the context of malignant pain may not be transferable to chronic non-malignant pain. Opioids are generally not the best choice of medication for controlling neuropathic pain. Tricyclics, SNRIs, and anticonvulsants should be tried before considering opioids for neuropathic pain.

[a]. In most cases, analgesic treatment should begin with acetaminophen, aspirin, NSAIDs, and possibly Baclofen or Tizanidine. While maximum efficacy is modest, they may reduce pain sufficiently to permit adequate function. When these drugs do not satisfactorily reduce pain, medications specific to the diagnosis should be used (e.g., neuropathic pain medications as outlined in Medications and Medical Management).

[b]. There is good evidence from a prospective cohort study that in the setting of common low back injuries, when baseline pain and injury severity are taken into account, a prescription for more than seven days of opioids in the first six weeks is associated with an approximate doubling of disability one year after the injury. Therefore, prescribing after two weeks in a non-surgical case requires a risk assessment. If prescribing beyond four weeks, a full opioid trial is suggested including toxicology screen. Best practice suggests that whenever there is use of opioids for more than seven days, providers should follow all recommendations for screening and follow-ups of chronic pain use.

[c]. Consultation or referral to a pain specialist behavioral therapist should be considered when the pain persists but the underlying tissue pathology is minimal or absent and correlation between the original injury and the severity of impairment is not clear. Consider consultation if suffering and pain behaviors are present and the patient manifests risk behaviors described below, or when standard treatment measures have not been successful or are not indicated.

[d]. A psychological consultation including psychological testing (with validity measures) is indicated for all chronic pain patients as these patients are at high risk for unnecessary procedures and treatment and prolonged recovery.

[e]. Many behaviors have been found related to prescription-drug abuse patients. None of these are predictive alone, and some can be seen in patients whose pain is not under reasonable control; however, the behaviors should be considered warning signs for higher risk of abuse or addiction by physicians prescribing chronic opioids. Refer to Subsection, High Risk Behavior, below.

(ix). Recommendations for Opioid Use: When considering opioid use for moderate to moderately severe chronic pain, a trial of opioids must be accomplished as described below and the patient must have failed other chronic pain management regimens. Physicians should complete the education recommended by the FDA, risk

evaluation and mitigation strategies (REMS) provided by drug manufacturing companies.

[a]. General Indications. There must be a clear understanding that opioids are to be used for a limited term in the first instance (see trial indications below). The patient should have a thorough understanding of all of the expectations for opioid use. The level of pain relief is expected to be relatively small, two to three points on a VAS pain scale, although in some individual patients it may be higher. For patients with a high response to opioid use, care should be taken to assure that there is no abuse or diversion occurring. The physician and patient must agree upon defined functional goals as well as pain goals. If functional goals are not being met, the opioid trial should be reassessed. The full spectrum of side effects should be reviewed. The shared decision making agreement signed by the patient must clarify under what term the opioids will be tapered. Refer to Subsection on the shared decision making agreement, below.

[b]. Therapeutic Trial Indications. A therapeutic trial of opioids should not be employed unless the patient has begun multi-disciplinary pain management. The trial shall last one month. If there is no functional effect, the drug should be tapered. Chronic use of opioids should not be prescribed until the following have been met:

[i]. the failure of pain management alternatives, including active therapies, cognitive behavioral therapy, pain self-management techniques, and other appropriate medical techniques;

[ii]. physical and psychological and/or psychiatric assessment including a full evaluation for alcohol or drug addiction, dependence or abuse, performed by two specialists including the authorized treating physician and a physician or psychologist specialist with expertise in chronic pain. The patient should be stratified as to low, medium, or high risk for abuse based on behaviors and prior history of abuse. High risk patients are those with active substance abuse of any type or a history of opioid abuse. These patients should generally not be placed on chronic opioids. If it is deemed appropriate to do so, physician addiction specialists should be monitoring the care. Moderate risk factors include a history of non-opioid substance abuse disorder, prior trauma particularly sexual abuse, tobacco use, widespread pain, poor pain coping, depression, and dysfunctional cognitions about pain and analgesic medications (see below). Pre-existing respiratory or memory problems should also be considered. Patients with a past history of substance abuse or other psychosocial risk factors should be co-managed with a physician addiction specialist;

[iii]. risk factors to consider: history of severe post-operative pain, opioid analgesic tolerance (daily use for months), current mixed opioid agonist/antagonist treatment (e.g., buprenorphine, naltrexone), chronic pain (either related or unrelated to the surgical site), psychological comorbidities (e.g., depression, anxiety, catastrophizing), history of substance use disorder, history of "all over body pain", history of significant opioid

sensitivities (e.g., nausea, sedation), and history of intrathecal pump use or nerve stimulator implanted for pain control;

[iv]. employment requirements are outlined. The patient's employment requirements should also be discussed as well as the need to drive. It is generally not recommended to allow workers in safety sensitive positions to take opioids. Opioid naïve patients or those changing doses are likely to have decreased driving ability. Some patients on chronic opioids may have nominal interference with driving ability; however, effects are specific to individuals. Providers may choose to order certified driver rehabilitation assessment;

[v]. urine drug screening for substances of abuse and substances currently prescribed. Clinicians should keep in mind that there are an increasing number of deaths due to the toxic misuse of opioids with other medications and alcohol. Drug screening is a mandatory component of chronic opioid management. It is appropriate to screen for alcohol and marijuana use and have a contractual policy regarding both alcohol and marijuana use during chronic opioid management. Alcohol use in combination with opioids is likely to contribute to death;

[vi]. review of the prescription monitoring program, Louisiana Revised Statutes 40:978 and 40:1001-1014. Informed, written, witnessed consent by the patient including the aspects noted above. Patients should also be counseled on safe storage and disposal of opioids;

[vii]. the trial, with a short-acting agent, should document sustained improvement of pain control, at least a 30 percent reduction, and of functional status, including return-to-work, and/or increase in activities of daily living. It is necessary to establish goals which are specific, measurable, achievable, and relevant prior to opioid trial or adjustment to measure changes in activity/function. Measurement of functional goals may include patient completed validated functional tools. Frequent follow-up at least every two to four weeks may be necessary to titrate dosage and assess clinical efficacy.

[c]. On-going, long-term management after a successful trial should include:

[i]. prescriptions from a single practitioner;

[ii]. ongoing review and documentation of pain relief, functional status, appropriate medication use, and side effects; full review at least every three months;

[iii]. ongoing effort to gain improvement of social and physical function as a result of pain relief;

[iv]. review of the Prescription Monitoring Program (PMP);

[v]. shared decision making agreement detailing the following:

{a}. side effects anticipated from the medication;

{b}. requirement to continue active therapy;

{c}. need to achieve functional goals including return to work for most cases;

{d}. reasons for termination of opioid management, referral to addiction treatment, or for tapering opioids (tapering is usually for use longer than 30 days). Examples to be included in the contract include, but are not limited to:

{i}. diversion of medication;

{ii}. lack of functional effect at higher doses;

{iii}. non-compliance with other drug use;

{iv}. drug screening showing use of drugs outside of the prescribed treatment or evidence of non-compliant use of prescribed medication;

{v}. requests for prescriptions outside of the defined time frames;

{vi}. lack of adherence identified by pill count, excessive sedation, or lack of functional gains;

{vii}. excessive dose escalation with no decrease in use of short-term medications;

{viii}. apparent hyperalgesia;

{ix}. shows signs of substance use disorder (including but not limited to work or family problems related to opioid use, difficulty controlling use, craving);

{x}. experiences overdose or other serious adverse event;

{xi}. shows warning signs for overdose risk such as confusion, sedation, or slurred speech.

{e}. patient agreements should be written at a sixth grade reading level to accommodate the majority of patients;

{f}. use of random drug screening, initially, four times a year or possibly more with documented suspicion of abuse or diversion or for stabilization or maintenance phase of treatment. In addition to those four or more random urine drug screens, quantitative testing is appropriate in cases of inconsistent findings, suspicions, or for particular medications that patient is utilizing that is not in the qualitative testing;

{i}. drugs or drug classes for which screening is performed should only reflect those likely to be present based on the patient's medical history or current clinical presentation, illicit substances, the practitioner's suspicion, and without duplication;

{ii}. qualitative urine drug testing (UDT) (i.e., immunoassay to evaluate, indicates the drug is present) that is utilized for pain management or substance

abuse monitoring, may be considered medically necessary for: baseline screening/Induction phase before initiating treatment or at time treatment is initiated, stabilization phase of treatment with targeted weekly qualitative screening for a maximum of four weeks. (This type of monitoring is done to identify those patients who are expected to be on a stable dose of opioid medication within a four-week timeframe.) Maintenance phase of treatment with targeted qualitative screening once every one to three months. Subsequent monitoring phase of treatment at a frequency appropriate for the risk level of the individual patient. (This type of monitoring is done to identify those patients who are noncompliant or abusing prescription drugs or illicit drugs.) Note: In general, qualitative urine drug testing should not require more than four tests in a 12-month period. Additional testing, as listed above, would require clinical justification of medical necessity;

{iii}. quantitative UDT (i.e., gas chromatography and or mass spectrometry [GCMS] as confirmatory, indicates the amount of drug is present) that is utilized for pain management or substance abuse monitoring, may be considered medically necessary under the following circumstances: When immunoassays for the relevant drug(s) are not commercially available, or in specific situations when qualitative urine drug levels are required for clinical decision making. The following qualitative urine drug screen results must be present and documented: positive for a prescription drug that is not prescribed to the patient; or negative for a prescription drug that is prescribed to the patient; or Positive for an illicit drug;

{iv}. quantitative testing is not appropriate for every specimen and should not be done routinely. This type of test should be performed in a setting of unexpected results and not on all specimens. The rationale for each quantitative test must be supported by the ordering clinician's documentation. The record must show that an inconsistent positive finding was noted on the qualitative testing or that there was not an available qualitative test to evaluate the presence of semisynthetic or synthetic opioid, illicit drugs or other medications used for pain management in a patient. Simultaneous blood and urine drug screening or testing is not appropriate and should not be done;

{v}. urine testing, when included as one part of a structured program for pain management, has been observed to reduce abuse behaviors in patients with a history of drug misuse. Clinicians should keep in mind that there are an increasing number of deaths due to the toxic misuse of opioids with other medications and alcohol. Drug screening is a mandatory component of chronic opioid management. Clinicians should determine before drug screening how they will use knowledge of marijuana use. It is appropriate to screen for alcohol and marijuana use and have a contractual policy regarding both alcohol and marijuana use during chronic opioid management. Alcohol use in combination with opioids is likely to contribute to death. From a safety standpoint, it is more important to screen for alcohol use than marijuana use as alcohol is more likely to contribute to unintended overdose;

{vi}. physicians should recognize that occasionally patients may use non-prescribed substances because they have not obtained sufficient relief on the prescribed regime;

[vi]. chronic use limited to two oral opioids;

[vii]. transdermal medication use, other than buprenorphine, is generally not recommended;

[viii]. use of acetaminophen-containing medications in patients with liver disease should be limited; including over-the-counter medications. Acetaminophen dose should not exceed 4 grams per day for short-term use or 2 to 3 grams/day for long-term use in healthy patients. A safer chronic dose may be 1800 mg/day;

[ix]. continuing review of overall therapy plan with regard to non-opioid means of pain control and functional status;

[x]. tapering of opioids may be necessary for many reasons including the development of hyperalgesia, decreased effects from an opioid, lack of compliance with the opioid contract, or intolerance of side effects. Some patients appear to experience allodynia or hyperalgesia on chronic opioids. This premise is supported by a study of normal volunteers who received opioid infusions and demonstrated an increase in secondary hyperalgesia. Options for treating hyperalgesia include withdrawing the patient from opioids and reassessing their condition. In some cases, the patient will improve when off of the opioid. In other cases, another opioid may be substituted:

{a}. tapering may also be appropriate by patient choice, to accommodate “fit-for-duty” demands, prior to major surgery to assist with post-operative pain control, to alleviate the effects of chronic use including hypogonadism, medication side effects, or in the instance of a breach of drug agreement, overdose, other drug use aberrancies, or lack of functional benefit. It is also appropriate for any of the tapering criteria listed in Section E above;

{b}. generally, tapering can be accomplished by decreasing the dose 10 percent per week. This will generally take 6 to 12 weeks and may need to be done one drug class at a time. Behavioral support is required during this service. Tapering may occur prior to MMI or in some cases during maintenance treatment.

[xi]. medication assisted treatment with buprenorphine or methadone may be considered for opioid abuse disorder, in addition to behavioral therapy. Refer to Opioid Addiction Treatment;

[xii]. inpatient treatment may be required for addiction or opioid tapering in complex cases. Refer to Interdisciplinary Rehabilitation Programs for detailed information on inpatient criteria.

[d]. Relative Contraindications. Extreme caution should be used in prescribing controlled substances for workers with one or more “relative contraindications”:

Consultation with a pain or addiction specialist may be useful in these cases:

[i]. history of alcohol or other substance abuse, or a history of chronic, benzodiazepine use;

[ii]. sleep apnea: If patient has symptoms of sleep apnea, diagnostic tests should be pursued prior to chronic opioid use;

[iii]. off work for more than six months with minimal improvement in function from other active therapy;

[iv]. severe personality disorder or other known severe psychiatric disease per psychiatrist or psychologist;

[v]. monitoring of behavior for signs of possible substance abuse indicating an increased risk for addiction and possible need for consultation with an addiction specialist.

[e]. High Risk Behavior. The following are high risk warning signs for possible drug abuse or addiction. Patients with these findings may need a consultation by a physician experienced in pain management and/or addiction. Behaviors in the first list are warning signs, not automatic grounds for dismissal, and should be followed up by a reevaluation with the provider:

[i]. repeated behaviors in the first list may be more indicative of addiction and behaviors in the second list should be followed by a substance abuse evaluation:

{a}. first list: less suggestive for addiction but are increased in depressed patients—Frequent requests for early refills; claiming lost or stolen prescriptions; Opioid(s) used more frequently, or at higher doses than prescribed; Using opioids to treat non-pain symptoms; Borrowing or hoarding opioids; Using alcohol or tobacco to relieve pain; Requesting more or specific opioids; Recurring emergency room visits for pain; Concerns expressed by family member(s); Unexpected drug test results; Inconsistencies in the patient’s history.

{b}. second list: more suggestive of addiction and are more prevalent in patients with substance use disorder—Buying opioids on the street; stealing or selling drugs; Multiple prescribers (“doctor shopping”); Trading sex for opioids; Using illicit drugs; Positive urine drug tests for illicit drugs; Forging prescriptions; Aggressive demands for opioids; Injecting oral/topical opioids; Signs of intoxication (ETOH odor, sedation, slurred speech, motor instability, etc.);

[ii]. both daily and monthly users of nicotine were at least three times more likely to report non-medical use of opioid in the prior year. At least one study has demonstrated a prevalence of smokers and former smokers among those using opioids and at higher doses compared to the general population. It also appeared that smokers and former smokers used opioids more frequently and in higher doses than never smokers. Thus, tobacco use history may be a helpful prognosticator;



[iii].in one study, four specific behaviors appeared to identify patients at risk for current substance abuse: increasing doses on their own, feeling intoxicated, early refills, and oversedating oneself. A positive test for cocaine also appeared to be related;

[iv].One study found that half of patients receiving 90 days of continuous opioids remained on opioids several years later and that factors associated with continual use included daily opioid greater than 120 MED prior opioid exposure, and likely opioid misuse;

[v]. One study suggested that those scoring at higher risk on the Screener and Opioid Assessment for Patients with Pain-Revised (SOAPP-R), also had greater reductions in sensory low back pain and a greater desire to take morphine. It is unclear how this should be viewed in practice.

[f]. Dosing and Time to Therapeutic Effect. Oral route is the preferred route of analgesic administration because it is the most convenient and cost-effective method of administration. Transbuccal administration should be avoided other than for buprenorphine. A daily dosage above 50 MED may be appropriate for certain patients. However, when the patient's dosage exceeds 50 MED per day and/or the patient is sedentary with minimal function, consideration should be given to lowering the dosage. Some patients may require dosages above 90 MED per day. However, if the patient reaches a dosage above 90 MED per day, it is appropriate to taper or refer to a pain or addiction specialist. The provider should also adhere to all requirements in this guideline and closely monitor the patient as this is considered a high risk dosage. In some cases, buprenorphine may be a preferred medication for pain control in those patients. Consultation may be necessary.

[g]. Major Side Effects. There is great individual variation in susceptibility to opioid-induced side effects and clinicians should monitor for these potential side effects. Common initial side effects include nausea, vomiting, drowsiness, unsteadiness, and confusion. Occasional side effects include dry mouth, sweating, pruritus, hallucinations, and myoclonus. Rare side effects include respiratory depression and psychological dependence. Constipation and nausea/vomiting are common problems associated with long-term opioid administration and should be anticipated, treated prophylactically, and monitored constantly. Stool softeners, laxatives, and increased dietary fluid may be prescribed. Refer to Opioid Induced Constipation. Chronic sustained release opioid use is associated with decreased testosterone in males and females and estradiol in pre-menopausal females. Patients should be asked about changes in libido, sexual function, and fatigue. Appropriate lab testing and replacement treatment should be completed.

[h]. Naloxone or oral and injection Naltrexone may be prescribed when any risk factors are present. The correct use of Naloxone and Naltrexone should be discussed with the patient and family.

[i]. Benzodiazepine: should not be prescribed when opioids are used.

[j]. Sedation: driving and other tasks. Although some studies have shown that patients on chronic opioids do not function worse than patients not on medication, caution should be exerted, and patients should be counseled never to mix opioids with the use of alcohol or other sedating medication. When medication is increased or trials are begun, patients should not drive for at least five days. Chronic untreated pain, sedatives especially when mixed with opiates or alcohol, and disordered sleep can also impair driving abilities.

[k]. Drug Interactions. Patients receiving opioid agonists should not be given a mixed agonist-antagonist such as pentazocine [Talacen, Talwin] or butorphanol [Stadol] because doing so may precipitate a withdrawal syndrome and increase pain.

[l]. All sedating medication, especially benzodiazepines, should be avoided or limited to very low doses. Over-the-counter medications such as antihistamines, diphenhydramine, and prescription medications such as hydroxyzine (Anx, Atarax, Atazine, Hypam, Rezine, Vistaril) should be avoided except when being used to manage withdrawal during tapering of opioids. Alcohol should not be used.

[m]. Recommended Laboratory Monitoring. Primary laboratory monitoring is recommended for acetaminophen/aspirin/NSAIDs combinations (renal and liver function, blood dyscrasias) although combination opioids are not recommended for long-term use. Morphine and other medication may require renal testing and other screening. A comprehensive genetic testing panel may be ordered by treating physician for these multiple P450 genes once in a lifetime and utilized whenever there is a question of metabolism or unusual response of any drugs used to treat pain conditions, because multiple drugs and associated genes can cause problems with opioid metabolism.

[n]. Sleep Apnea Testing. Both obstructive and central sleep apnea are likely to be exaggerated by opioid use or may occur secondary to higher dose chronic opioid use and combination medication use, especially benzodiazepines and sedative hypnotics. Patients should be questioned about sleep disturbance and family members or sleeping partners questioned about loud snoring or gasping during sleep. If present, qualified sleep studies and sleep medicine consultation should be obtained. Portable sleep monitoring units are generally not acceptable for diagnosing primary central sleep apnea. Type 3 portable units with two airflow samples and an O2 saturation device may be useful for monitoring respiratory depression secondary to opioids, although there are no studies on this topic.

[o]. Regular Consultation of the Prescription Monitoring Program (PMP). Physicians should review their patients on the system whenever drug screens are done. This information should be used in combination with the drug screening results, functional status of the patient, and other

laboratory findings to review the need for treatment and level of treatment appropriate for the patient.

[o]. Addiction. If addiction occurs, patients will require treatment. Refer to Opioid Addiction Treatment. After detoxification, they may need long-term treatment with naltrexone (Depade, ReVia, Vivitrol), an antagonist which can be administered in a long-acting form or buprenorphine which requires specific education per the Drug Enforcement Agency (DEA).

[p]. Potentiating Agents. There is some evidence that dextromethorphan does not potentiate the effect of morphine opioids and therefore is not recommended to be used with opioids.

vii. Post-Operative Pain Management. Proper post-operative pain management may avoid overuse and misuse of opioids. A recent practice guideline strongly recommends a multi-modal approach to post-operative pain. Suggestions include use of TENS, cognitive behavioral therapy, use of oral medication over parenteral medication and patient controlled analgesia when parenteral medication is used, use of NSAIDS (for appropriate procedures) or acetaminophen, gabapentin or pregabalin may also be used, and peripheral regional anesthesia when appropriate. Ketamine is also suggested for major surgeries, patients with high opioid tolerance or those who have difficulty tolerating opioids. However, ketamine does have side effects such as hallucination and nightmares. It is not recommended as a first line medication for most patients. A Comprehensive genetic testing panel may be ordered by treating physician for these multiple P450 genes once in a lifetime and utilized whenever there is a question of metabolism or unusual response of any drugs used to treat pain conditions, because multiple drugs and associated genes can cause problems with opioid metabolism.

(a). Pre-operative psychological preparation or neuroscience education may improve post-operative pain management. Pre-operative cognitive-behavioral therapy or other psychological intervention likely improves in-hospital mobilization and analgesic use for lumbar spinal fusion patients and for other surgical patients. One randomized study compared patients who received one session of pre-operative pain neuroscience education from physical therapist prior to lumbar discectomy and those who did not. There was no change in the primary outcomes from surgery. However, significant changes occurred in secondary outcomes which included preparation for surgery, surgery meeting their expectations, and a 45 percent decrease in health expenditure for the follow up year. Thus, pre-operative pain neuroscience education may prove a useful addition for any patient prior to surgical decisions. Refer to Therapy-Active, for a description of Pain Neuroscience Education. Optimal surgical outcomes are more likely when the patient commits to a post-operative active therapy program.

(b). Generally, post-operative pain management is under the supervision of the surgeon and hospitalist with the goal of returning to the pre-operative level of

pharmaceutical management. For a specific procedure's post-operative management, refer to the related medical treatment guideline.

(c). Surgical procedures may be necessary for patients already taking chronic opioids, and they may encounter difficulty with pain control post-operatively. These patients will usually require higher doses of opioids during their post-operative phase and may benefit the most from multimodal therapy and/or ketamine as described in Topical Drug Delivery. It is strongly advised that physicians consult a pain specialist or addiction specialist when caring for post-operative patients with a history of substance abuse or previous addiction. Refer to Post-Operative Pain Management.

viii. Skeletal muscle relaxants are most useful for acute musculoskeletal injury or exacerbation of injury. Chronic use of benzodiazepines or any muscle relaxant is not recommended due to their habit-forming potential, seizure risk following abrupt withdrawal, and documented contribution to deaths of patients on chronic opioids due to respiratory depression.

(a). Baclofen (intrathecal or oral):

(i). description: may be effective due to stimulation of Gamma Aminobutyric Acid (GABA) receptors;

(ii). Indications: pain from muscle rigidity. As of the time of this guideline writing, formulations of baclofen injection have been FDA approved for the management of severe spasticity of a spinal cord or cerebral origin;

(iii). side effects: exacerbation of psychotic disorders, may precipitate seizures in epileptics, dry mouth, and sexual dysfunction;

(iv). recommended laboratory monitoring: renal and hepatic function;

(v). caution: abrupt discontinuation of baclofen can precipitate a withdrawal syndrome and has been seen with both low and high doses. The most common side effects of baclofen withdrawal include pruritis, tremor, and mood disturbance. In extreme circumstances, seizures, muscle rigidity (resembling neuroleptic malignant syndrome), and even death can occur.

(b). Cyclobenzaprine (Amrix, Fexmid, Flexeril):

(i). description: structurally related to tricyclics;

(ii). indications—acute exacerbated chronic pain associated with muscle spasm. As of the time of this guideline writing, formulations of this drug are FDA approved as an adjunct to rest and physical therapy for relief of muscle spasm associated with acute, painful musculoskeletal conditions. It should only be used for short periods (less than two weeks) because of lack of evidence for effectiveness with prolonged use;

(iii). major contraindications: cardiac dysrhythmias;

(iv). dosing and time to therapeutic effect: variable, onset of action is one hour;

(v). major side effects: sedation, anticholinergic, blurred vision. Patients should also be monitored for suicidal ideation and drug abuse;

(vi). drug interactions: contraindicated for use with MAO inhibitors; interacts with tramadol, duloxetine, escitalopram, and fluoxetine. Likely interactions with other SSRIs and SNRIs. Drug interactions are similar to those for tricyclics. Refer also to information on tricyclics in Medications and Medical Management;

(vii). recommended laboratory monitoring: hepatic and renal function.

(c). Carisoprodol (Soma, Soprodal, Vanadom): This medication should not be used in chronic pain patients due to its addictive nature secondary to the active metabolite meprobamate.

(d). Metaxalone (Skelaxin):

(i). description: central acting muscle relaxant;

(ii). indications: acute exacerbated chronic pain associated with muscle spasm. As of the time of this guideline writing, formulations of this drug are FDA approved as an adjunct to rest and physical therapy for relief of muscle spasm associated with acute, painful musculoskeletal conditions. It should only be used for short periods (less than two weeks) because of lack of evidence for effectiveness with prolonged use;

(iii). major contraindications: significantly impaired renal or hepatic disease, pregnancy, and disposition to drug induced hemolytic anemia;

(iv). dosing and time to therapeutic effect: 800 mg, three to four times per day, onset of action one hour;

(v). major side effects: sedation, hematologic abnormalities;

(vi). drug interactions: other sedating drugs (e.g., opioids, benzodiazepines);

(vii). recommended laboratory monitoring: hepatic function, CBC.

(e). Methocarbamol:

(i). description: central action muscle relaxant;

(ii). indications: muscle spasm;

(iii).major contraindications: hypersensitivity, possible renal compromise;

(iv).dosing and time to therapeutic effect: 1500 mg. four times per day. Longer dosing 4000 to 4500 mg per day;

(v). major side effects: decreased cognition, light headedness, GI effects among other;

(vii). drug interactions: alcohol and other CNS depressants.

(f). Tizanidine (Zanaflex):

(i). description: alpha 2 adrenergic agonist;

(ii). indications: true centrally mediated spasticity, musculoskeletal disorders. As of the time of this guideline writing, formulations of tizanidine have been FDA approved for the management of spasticity in spinal cord injury and multiple sclerosis;

(iii). major contraindications: concurrent use with ciprofloxacin (Cipro, Proquin) or fluvoxamine (Luvox); or hepatic disease;

(iv). dosing and time to therapeutic effect: 4 mg/day orally and gradually increase in 2 to 4 mg increments on an individual basis over two to four weeks; maintenance, 8 mg orally every six to eight hours (max dose 36 mg/day);

(v). major side effects: hypotension, sedation, hepatotoxicity, hallucinations and psychosis, dry mouth;

(vi). drug interactions. Alcohol can increase sedation, and concurrent use with ciprofloxacin or fluvoxamine is contraindicated. Several other medications increase tizanidine plasma concentrations (e.g., oral contraceptives, verapamil, and cimetidine). Use with caution with other alpha agonists and other antihypertensives as they may increase the risk of hypotension;

(vii). laboratory monitoring: hepatic function, blood pressure.

ix. Smoking Cessation Medications and Treatment. Tobacco dependence is chronic and may require repeated attempts to quit. All smoking cessation programs should be accompanied by behavioral support which may include practical counseling sessions and social support, which usually includes telephone follow-up. A variety of medications have been used including Bupropion SR, nicotine patches, gum, inhaler, lozenges or nasal spray, and varenicline. When nicotine supplements are used, cotinine testing will be positive. Urine anabasine or exhaled carbon monoxide 5 ppm or less may be used to check tobacco abstinence.

(a). There is some evidence that among adults motivated to quit smoking, 12 weeks of open-label treatment including counseling and one of the following: nicotine patch, varenicline, or combination nicotine replacement therapy (nicotine patch and nicotine lozenge) are equally effective in assisting motivated smokers to quit smoking over a period of one year.

(b). There is some evidence that among adults motivated to quit smoking, abrupt smoking cessation is the more effective method that leads to lasting abstinence over a period of four weeks to six months compared to gradual

cessation, even for smokers who initially prefer to quit by gradual reduction.

x. Topical Drug Delivery

(a). Description. Topical creams and patches may be an alternative treatment of localized musculoskeletal and neuropathic disorders and can be especially helpful in avoiding opioid use.

(b). Indications: neuropathic pain for many agents; episodic use of NSAIDs and salicylates for joint pain or musculoskeletal disorders. All topical agents should be used with strict instructions for application as well as maximum number of applications per day to obtain the desired benefit and avoid potential toxicity.

(c). Dosing and time to therapeutic effect: all topical agents should be prescribed with clear instructions for application and maximum number of applications per day to obtain the desired benefit and avoid potential toxicity. For most patients, the effects of long-term use are unknown. Thus, episodic use may be preferred for some agents.

(d). Side Effects. localized skin reactions may occur, depending on the medication agent used.

(e). Topical Agents

(i). Capsaicin. As of the time of this guideline writing, formulations of capsaicin have been FDA approved for management of pain associated with post-herpetic neuralgia. Capsaicin offers a safe and effective alternative to systemic NSAID therapy. Although it is quite safe, the local stinging or burning sensation that typically dissipates with regular use, usually after the first 7 to 10 days of treatment, limits effective use of capsaicin. Patients should be advised to apply the cream on the affected area with a plastic glove or cotton applicator and to avoid inadvertent contact with eyes and mucous membranes.

[a]. There is good evidence that low dose capsaicin (0.075 percent) applied four times per day will decrease pain up to 50 percent. There is strong evidence that a single application of eight percent capsaicin is more effective than a control preparation of 0.04 percent capsaicin for up to 12 weeks. However, there may be a need for frequent application, and it is not known whether subsequent applications of capsaicin are likely to be as effective as the first application. There is some evidence that in patients who are being treated with capsaicin 8 percent patches, two methods of pre-treatment are equally effective in controlling application pain and in enabling patients to tolerate the patch: topical four percent lidocaine cream applied to the area for one hour before placement of the capsaicin patch and 50 mg oral tramadol taken 30 minutes before patch placement.

(ii). Clonidine. There is good evidence that topical clonidine gel 0.1 percent is likely to alleviate pain from diabetic peripheral neuropathy in patients who display a nociceptive response to the application of 0.1 percent capsaicin applied to the pretibial area. It is likely that patients who do not display a pain response to pretibial

capsaicin are not likely to have a clinically meaningful analgesic response to clonidine gel. It is unknown if this screening test applies to other types of neuropathic pain. Clonidine gel may be used for neuropathic pain.

[a]. Lofexidine (Lucemyra) is now available and indicated for mitigation of opioid withdrawal symptoms to facilitate abrupt discontinuation in adults. This is necessary to block or reduce life threatening side effects of opioid withdrawal. This drug will be beneficial in drug treatment centers and for physicians finding necessity to abruptly stop opioid medication.

(iii). Ketamine and Tricyclics. Topical medications, such as the combination of ketamine and amitriptyline, have been proposed as an alternative treatment for neuropathic disorders including CRPS. A study using a 10 percent concentration showed no signs of systemic absorption. This low-quality study demonstrated decreased allodynia at 30 minutes for some CRPS patients. However, as of the time of this guideline writing, neither tricyclic nor ketamine topicals are FDA approved for topical use in neuropathic pain. Furthermore, there is good evidence that neither two percent topical amitriptyline nor 1 percent topical ketamine reduces neuropathic pain syndromes. Despite the lack of evidence, it is physiologically possible that topical tricyclics and a higher dose of ketamine could have some effect on neuropathic pain. Other less expensive topicals and compounds, including over-the-counter, should be trialed before more expensive compounds are ordered. The use of topical tricyclics and/or ketamine should be limited to patients with neuritic and/or sympathetically mediated pain with documented supporting objective findings such as allodynia and/or hyperalgesia. Continued use of these agents beyond the initial prescription requires documentation of effectiveness, including functional improvement, and/or decreased use of other medications, particularly decreased use of opioids or other habituating medications.

(iv). Lidocaine. As of the time of this guideline writing, formulations of lidocaine (patch form) have been FDA approved for pain associated with post-herpetic neuralgia. Evidence is mixed for long-term use of lidocaine topically. Physicians should always take into account the blood level that may be achieved with topical use as toxic levels have been reported and there is variability and systemic absorption among individuals. There is good evidence that lidocaine five percent plasters, applied for up to 12 hours to the lower extremities of patients with post-herpetic neuralgia and diabetic painful neuropathy, is non-inferior to pregabalin for the same indications. The topical lidocaine is associated with significantly fewer drug-related adverse events over four weeks of observation. There is some evidence that a five percent lidocaine patch may be used as a secondary option for patients with focal neuropathic pain. A 30 to 50 percent pain reduction may be achieved in those who tolerate the patch. Up to three patches may be used simultaneously for 12 hours per day. It should be applied only to intact skin. Metered dose eight percent pump sprays have also been used and usually require a three

times per day reapplication. There is some evidence that the eight percent sprays are effective for short-term, two-week use. However, the effects of long-term use are unknown.

(v). Topical Salicylates and Nonsalicylates have been shown to be effective in relieving pain in acute musculoskeletal conditions and single joint osteoarthritis. Topical salicylate and nonsalicylates achieve tissue levels that are potentially therapeutic, at least with regard to COX inhibition.

[a]. There is insufficient evidence to support the use of topical rubefacients containing salicylates for acute injuries or chronic conditions. They seem to be relatively well tolerated in the short-term, based on limited data. The amount and quality of the available data mean that uncertainty remains about the effects of salicylate-containing rubefacients.

[b]. There is good evidence that diclofenac gel (Voltaren, Solaraze) reduces pain and improves function in mild-to-moderate hand osteoarthritis. There is good evidence that topical diclofenac and ketoprofen are more effective than placebo preparations for purposes of relieving pain attributable to knee osteoarthritis. There is good evidence that topical NSAIDs probably reduce the risk of GI adverse effects by approximately one-third compared to oral NSAIDs. Topical diclofenac does not appear to affect the anti-platelet properties of aspirin unlike the oral version. The topical solution of two percent sodium diclofenac applied thrice a day is equal to 1.5 percent four times per day.

[c]. Diclofenac gel has been FDA approved for acute pain due to minor strains, pains, and contusions and for relief of pain due to osteoarthritis of the joints amenable to topical treatment, such as those of the knees, shoulders, and hands. It is likely that other NSAIDs would also be effective topically. Thus, topical NSAIDs are permitted when patients show functional improvement.

[d]. Other than local skin reactions, the side effects of therapy are minimal, although not non-existent. The usual contraindications to use of these compounds needs to be considered. Local skin reactions are rare and systemic effects are even less common. Their use in patients receiving warfarin therapy may result in alterations in bleeding time. Overall, the low level of systemic absorption can be advantageous. This allows the topical use of these medications when systemic administration is relatively contraindicated, such as is the case in patients with hypertension, cardiac failure, or renal insufficiency. Both topical salicylates and NSAIDs are appropriate for many chronic pain patients. However, in order to receive refills, patients should demonstrate increased function, decreased pain, or decreased need for oral medications.

(vi). Other Compounded Topical Agents. At the time of writing this guideline, no studies identified evidence for the effectiveness of compounded topical agents other than those recommended above. Therefore, other compounded topical agents are not generally recommended. In rare cases, they may be appropriate for patients who prefer a topical medication to chronic opioids or who have

allergies or side effects from other more commonly used oral agents.

(vii). Prior authorization is required for all agents that have not been recommended above.

#### xi. Other Agents

(a). Glucosamine. There is good evidence that glucosamine does not improve pain related disability in those with chronic low back pain and degenerative changes on radiologic studies; therefore, it is not recommended for chronic lower spinal or non-joint pain. For chronic pain related to joint osteoarthritis, see specific extremity guidelines. Glucosamine should not be combined with chondroitin as it is ineffective.

(b). Oral Herbals. There is insufficient evidence due to low quality studies that an oral herbal medication, Compound Qishe Tablet, reduced pain more than placebo. There is also insufficient evidence that Jingfukang and a topical herbal medicine, Compound Extractum Nucis Vomicae, reduced pain more than Diclofenac Diethylamine Emulgel. Further research is very likely to change both the effect size and our confidence in the results. Currently, no oral herbals are recommended.

(c). Vitamin D. A large beneficial effect of vitamin D across different chronic painful conditions is unlikely. Therefore, it is not recommended.

(d). Alpha-Lipoic Acid. An adequate meta-analysis shows that there is some evidence that alpha-lipoic acid at a dose of 600 mg per day may reduce the symptoms of painful diabetic neuropathy in the short term of three to five weeks. The effect of the intravenous route appears to be greater than that of the oral route, but the oral route may have a clinically relevant effect. Doses of 1200 or 1800 mg have not been shown to have additional therapeutic benefit. This medication may be used for neuropathic pain.

11. Non-Invasive Brain Stimulation. This has been proposed as a treatment for chronic pain. Varieties include repetitive transcranial magnetic stimulation (rTMS), cranial electrotherapy stimulation (CES), and transcranial direct current stimulation (tDCS).

a. Single doses of high-frequency rTMS of the motor cortex may have small short-term effects on chronic pain. It is likely that multiple sources of bias may exaggerate this observed effect. The effects do not meet the predetermined threshold of minimal clinical significance and multiple-dose studies do not consistently demonstrate effectiveness. The available evidence suggests that low-frequency rTMS, rTMS applied to the pre-frontal cortex, CES, and tDCS are not effective in the treatment of chronic pain.

b. Therefore, these devices are not recommended due to lack of evidence and safety concerns.

12. Opioid Addiction Treatment. The DSM-V renames opioid addiction as substance use disorder (SUD) and classifies opioid use disorder according to categories defined as mild (two to three features of stated criteria), moderate

(four to five features of stated criteria), or severe (six to seven features of stated criteria).

a. Definitions

i. *Opioid Physical Dependence*—opioid withdrawal symptoms (withdrawals) which occur as a result of abrupt discontinuation of an opioid in an individual who became habituated to the medication or through administration of an antagonist. Opioid physical dependency is not in and of itself consistent with the diagnosis of addiction/substance use disorder.

ii. *Tolerance*—a physiologic state caused by the regular use of an opioid in which increasing doses are needed to maintain the same affect. In patients with "analgesic tolerance," increased doses of the opioid may be needed to maintain pain relief.

iii. *Opioid Misuse*—the utilization of opioid medications outside of the prescribing instructions for which it was originally prescribed. Misuse may be as innocuous as taking slightly more or less medications than prescribed to crushing or snorting an opioid.

iv. *Opioid Abuse*—the use of any substance for a non-therapeutic purpose or the use of a medication for purposes other than those for which the agent is prescribed. Abuse includes intentional use for altering a state of consciousness. Abuse frequently affects the individual's ability to fulfill normal societal roles, resulting in difficulty with employment, or legal, or interpersonal problems.

v. *Pseudo-Addiction*—addiction-like behaviors consistent with overutilization of medications outside of the prescribing provider's instructions and recommendations for the express purpose of improved pain management. This occurs when a patient believes there is insufficient pain relief. Once pain is adequately managed with a higher dose of medications than initially prescribed or with improved therapy, the behaviors consistent with addiction are discontinued.

vi. *Addiction*—a primary chronic neurobiological disease influenced by genetic, psychosocial, and/or environmental factors. It is characterized by impaired control over drug use, compulsive drug use, and continued drug use despite harm and because of craving.

b. Substance use disorder/addiction in the workers' compensation system can be encountered in three ways. First, the individual has an active substance use disorder at the time of injury. The party responsible for treatment of the substance use disorder may be outside of the workers' compensation system. However, if there is no other paying party and the treatment is necessary in order to recover from the current workers' compensation injury, treatment may be covered by the workers' compensation payor. The second possibility is that a patient with a substance use disorder, who is currently in recovery at the time of the workers' compensation injury, relapses as a result of the medications which are prescribed by the treating provider. This patient may become re-addicted and will manifest substance use disorder characteristics and symptoms consistent with the

diagnosis. The third possibility is an individual with no history of substance use disorder who is injured as a result of an occupational accident. This particular individual becomes "addicted" to the medications as a result of the medications being prescribed. This is most likely to occur with the use of opioids but could possibly occur with use of other medications such as benzodiazepines or specific muscle relaxants such as carisoprodol.

c. If the treating provider is suspicious of a patient exhibiting opioid misuse, abuse, or addiction, the patient should preferably be evaluated by a specialist in the field of addiction medicine. It would be the responsibility of the specialist to identify medication misuse, abuse, addiction, or pseudo-addiction and to determine what additional treatment, if any, needs to be implemented.

d. During the initial injury evaluation, an authorized treating provider should obtain an addiction history as part of a complete history and physical. If it is determined at the time of the initial evaluation by the treating provider that there is the pre-existing condition of active SUD or history of opioid addiction/SUD, then it is prudent to consider an evaluation with an addiction medicine physician prior to issuing opioid treatments if possible. The addiction medicine specialist will be able to counsel the patient accordingly, determine medication needs, and determine the appropriate follow-up to hopefully avoid aggravation or relapse of substance abuse disorders which will complicate the recovery process. Many patients exhibit opioid misuse, opioid abuse, and pseudo-addictive behaviors. These issues can be managed once the problem is identified and a discussion is carried out with the patient regarding these abnormal behaviors.

e. Once the diagnosis of SUD is confirmed, an addiction medicine trained physician familiar with addiction treatment should assist in co-managing the patient's care and the problematic drug prescriptions. This co-management technique is critical for the injured worker with a SUD diagnosis during the initial injury phase, recovery, and stabilization phase until he/she has reached MMI. If it is determined during the active treatment and recovery phase that there is no longer a need for opioids, then the addiction medicine trained physician will be in charge of the transition from use of opioids to safe taper/discontinuation of the opioids while monitoring for relapse of addiction.

f. Co-management is equally important for managing the chronic pain patient that has a concomitant opioid addiction/SUD with a legitimate need for analgesic medications. The addiction medicine trained physician in all likelihood will monitor the patient more closely including judicious prescribing, PMP reviews, urine drug testing, drug counts, and clarifying functional improvement as a result of the medications prescribed and frequent follow-ups which may initially seem excessive.

g. All abstinence addiction treatment begins with a discontinuation of the addicting substance; this is referred to as the detox phase of the treatment and can be performed in a number of ways. However, detoxification alone is not

considered adequate addiction treatment. Detoxification is simply a method of discontinuing the medications in an effort to stabilize the patient prior to more extensive treatment.

h. Phase 1

i. The methods of detoxification can include: abrupt discontinuation, not recommended due to high rate of relapse due to craving and withdrawal symptoms; slow but progressive taper, 10 percent of total dosage per week as an outpatient treatment; conversion to a different medication opioid (buprenorphine/naloxone) to enable a more stable and comfortable taper occasionally done as an outpatient but commonly done as part of a more comprehensive treatment program, and; rapid detox under anesthesia, not recommended due to relatively high incidence of complications and high expense. The methodology chosen for phase 1 detoxification is left up to the specialist and is simply the initial phase of stabilization prior to considering the need for a phase 2 of addiction treatment program.

i. Phase 2

i. Once a patient is safely through the detoxification phase and the condition is stabilized regardless of the method chosen, then successful addiction treatment begins generally utilizing a number of techniques to prevent the return to active substance use and addiction. This phase of treatment generally involves teaching the patient to develop control over the compulsions, psychosocial factors, and associated mental health issues which are critical to maintain abstinence. This phase of treatment is generally managed in a 30-90 day non-hospital residential treatment program. The treatment prescribed in a residential treatment program generally includes individual and group therapy with certified addiction counselors and psychologists. Phase 2 of treatment may or may not be combined with opioid substitution therapy with medications such as buprenorphine/naloxone (partial agonist of the opioid receptor), methadone, or naltrexone. Injectable depot naltrexone may be used.

ii. Buprenorphine/naloxone therapy utilizes a sublingual partial opioid receptor agonist which binds to the opioid receptor, reducing craving and resulting in analgesia when necessary. Due to its high affinity to the opioid receptor, it blocks the effect of non-approved additional opioid use. The buprenorphine is administered either sublingually or, when FDA approved, as a subcutaneous implant. Naloxone was added to the sublingual drug formulation to discourage using this medication intravenously. With intravenous administration of buprenorphine/naloxone, the naloxone becomes absorbed neutralizing the effects of opioids. Buprenorphine/naloxone can be an excellent option in patients requiring analgesic medications with a prior history of opioid addiction because buprenorphine results in less sedation and euphoria than the other standard schedule II opioid medications. Prescribing Suboxone film (buprenorphine/naloxone) for addiction purposes can only be done by a physician and requires special training and certification. Once special training is

completed, an application is filed with the DEA to obtain a special DEA license referred to as an X-DEA number. This X-DEA number needs to accompany all prescription for Suboxone when delivered to the pharmacy and identifies the prescription is being issued specifically for the treatment of addiction/SUD.

iii. Methadone may be an option if the patient is admitted to a federally licensed methadone treatment facility where a daily dose of medication is administered and the patient continues to utilize therapeutic treatments/cognitive behavioral therapies as noted above. There is strong evidence that in patients being treated with opioid agonists for heroin addiction, methadone is more successful than buprenorphine at retaining patients in treatment. The rates of opiate use, as evidenced by positive urines, are equivalent between methadone and buprenorphine. The methodology and rationale for methadone treatment is to saturate the opioid receptors with methadone (a slow onset and prolonged duration opioid), reducing the opioid craving. The majority of the opioid receptors are bound by the methadone leaving very few unbound opioid receptors available in the event additional opioids are utilized in an attempt to achieve the euphoric effect. When the patient is stabilized on a methadone dose determined by the federally licensed methadone clinic and their associated physicians, the patient's drug-seeking, craving, legal issues, and attempts to utilize non-approved medications is reduced. Patients will frequently return to more productive lives free of the compulsions, cravings, and legal issues and are usually able to maintain jobs and improve family dynamics.

iv. Other medications which may be useful and can be utilized during the phase 2 and 3 treatment include opioid receptor antagonists such as naltrexone (ReVia, Vivitrol) which produces no euphoria. The purpose of naltrexone therapy is to add an additional layer of protection and treatment for the patients by allowing them to receive a daily oral dose of naltrexone (ReVia) or a monthly injection of naltrexone (Vivitrol). Administration of naltrexone will bind with very high affinity to the opioid receptor resulting in the opioid receptors being non-responsive to other opioid utilization thereby preventing any euphoric response or reinforcement with unsanctioned opioid use. This treatment method can be problematic in an individual receiving intramuscular naltrexone therapy especially if that individual requires surgery and post-operative pain management because the analgesics needed for post-operative pain management will be significantly less effective because of the prolonged opioid antagonist properties of the naltrexone.

j. In Summary

i. Medication assisted treatment for patients addicted to opioids is the treatment recommended by most experts. A Canadian evidence-based guideline recommends long-term treatment with buprenorphine/naloxone, or methadone for some patients, based on the high relapse rate without medication assistance. The likelihood of relapse in the workers' compensation population for individuals who have become addicted through prescription drug use is unknown. Buprenorphine implants are likely equally

effective as sublingual buprenorphine for preventing illicit opioid use. Implants are significantly costlier. Naltrexone treatment, an opioid agonist, has also been used to maintain abstinence. It can be provided in monthly injections or orally three times per week. Choice of these medications should be made by the addiction specialist.

k. Phase 3

i. Aftercare begins after discharge from the non-hospital residential treatment program and is designed for long-term management of addiction. This phase is potentially the time when relapse is most likely to occur if the patient has not developed significant skills necessary to deal with the compulsions, cravings, and associated psychosocial factors contributing to SUD. Long-term strategies include: intense outpatient programs (IOP); group therapy/meetings such as Narcotics Anonymous, and; residential communities (RC) which are groups of patients living together in a community for up to six months for the express purpose of maintaining abstinence from their drug of choice but at the same time transitioning and learning how to live in the general community. Residential communities are extremely useful to give patients an opportunity to be reintroduced to employment and psychosocial interactions with family and friends while maintaining contact with the community supporting their addiction recovery. In addition, phase 3 medication treatment may include utilization of opioid substitution therapy (buprenorphine/naloxone) or opioid receptor antagonist therapy as noted above.

ii. It must be noted that relapse is common despite the utilization of intense cognitive behavioral therapy, addiction treatment strategies, and long-term phase 3 treatment and medication. Risk monitoring should be continued, including checking for behavioral aberrancies, checking the PMP, and drug testing. Additional treatment or readmission for repeat treatment is not uncommon.

### 13. Opioid/Chemical Treatment Program Requirements

a. Chemical dependency for workers' compensation issues will usually be related to opioids, anxiolytics, or hypnotics as prescribed for the original workers' compensation injury. Chemical dependency should be treated with specific programs providing medical and psychological assessment, treatment planning, and individual as well as group counseling and education. Established functional goals which are measurable, achievable, and time specific are required.

b. Inpatient or outpatient programs may be used, depending upon the level of intensity of services required. Formal inpatient treatment programs are appropriate for patients who have more intense (e.g., use extraordinarily excessive doses of prescription drugs to which they have developed tolerance) or multiple drug abuse issues (e.g., benzodiazepines and/or alcohol) and those with complex medical conditions or psychiatric issues related to drug misuse. A medical physician with appropriate training and preferably board certified in addiction medicine should provide the initial evaluation and oversee the program. Full

primary assessment should include behavioral health assessment; medical history; physical examination; mental status; current level of functioning; employment history; legal history; history of abuse, violence, and risk taking behavior; education level; use of alcohol, tobacco and other drugs; and social support system. The initial medical exam should include appropriate laboratory testing such as liver function, screening for sexual diseases, etc.

c. Addiction specialists, alcohol and drug counselors, psychologists, psychiatrists, and other trained health care providers as needed, are involved in the program. Peer and group support is an integral part of the program and families are encouraged to attend. Peer support specialists should receive competency-based training. A designated individual is assigned to each worker to assist in coordinating care. There should be good communication between the program and other external services, external health care providers, Al-Anon, Alcoholics Anonymous (AA), and pain medicine providers. Drug screening should be performed as appropriate for the individual, at least weekly during the initial detoxification and intensive treatment phases. Quarterly random drug screens per year should be completed for those that are being prescribed opioid medications and drug diversion control methods should be in place.

d. Clear withdrawal procedures are delineated for voluntary, against medical advice, and involuntary withdrawal. Withdrawal programs must have a clear treatment plan and include description of symptoms of opioid withdrawal, and actions taken. All programs should have clear direction on how to deal with violence in order to assure safety for all participants. Transition and discharge should be carefully planned with full communication to outside resources. Duration of inpatient programs are usually four weeks while outpatient programs may take 12 weeks.

e. Drug detoxification may be performed on an outpatient or inpatient basis. Detoxification is unlikely to succeed in isolation when not followed by prolonged chemical dependency treatment. Isolated detoxification is usually doomed to failure with very high recidivism rates.

f. Both ultra-rapid and rapid-detoxification are not recommended due to possible respiratory depression and death and the lack of evidence for long range treatment success. Refer to Opioid Addiction Treatment, for more specific details on treatment plans.

g. Tapering opioids on an outpatient basis requires a highly motivated patient and diligent treatment team and may be accomplished by decreasing the current dose 10 percent per day or per week. Tapering programs under the supervision of physicians with pain expertise may proceed more aggressively. Tapering should be accompanied by addiction counseling. Failing a trial of tapering, a patient should be sent to a formal addiction program. When the dose has reached one-third of the original dose, the taper should proceed at half or less of the initial rate. Doses should be held or possibly increased if severe withdrawal symptoms,



pain, or reduced treatment failure otherwise occurs. This method is tedious, time consuming, and more likely to fail than more rapid and formalized treatment programs.

h. Time frames for opioid / chemical treatment programs:

- i. time to produce effect: three to four weeks;
- ii. frequency: Full time programs - no less than five hours/day, five days/week; part time programs - four hours/day for two to three days per week;
- iii. optimum duration: 2 to 12 weeks at least two to three times a week. With follow-up visits weekly or every other week during the first one to two months after the initial program is completed;
- iv. maximum duration: four months for full time programs and up to six months for part-time programs. Periodic review and monitoring thereafter for one year, additional follow-up based upon the documented maintenance of functional gains.

#### 14. Orthotics/Prosthetics/Equipment

a. Devices and adaptive equipment may be necessary in order to reduce impairment and disability, to facilitate medical recovery, to avoid re-aggravation of the injury, and to maintain maximum medical improvement. Indications would be to provide relief of the industrial injury, prevent further injury and control neurological and orthopedic injuries for reduced stress during functional activities. In addition, they may be used to modify tasks through instruction in the use of a device or physical modification of a device. Equipment needs may need to be reassessed periodically. Refer to Return-to-work for more detailed information.

b. Equipment may include high and low technology assistive devices, computer interface or seating, crutch or walker training, and self-care aids. It should improve safety and reduce risk of re-injury. Standard equipment to alleviate the effects of the injury on the performance of activities of daily living may vary from simple to complex adaptive devices to enhance independence and safety. Certain equipment related to cognitive impairments may also be required.

c. Ergonomic modifications may be necessary to facilitate medical recovery, to avoid re-aggravation of the injury, and to maintain maximum medical improvement. Ergonomic evaluations with subsequent recommendations may assist with the patients return-to-work. (Refer to Job Site Evaluation for further information.)

d. For chronic pain disorders, equipment such as foot orthoses may be helpful. The injured worker should be educated as to the potential harm from using a lumbar support for a period of time greater than which is prescribed. Harmful effects include de-conditioning of the trunk musculature, skin irritation, and general discomfort. Use of cervical collars is not recommended for chronic cervical myofascial pain. Special cervical orthosis and/or equipment may have a role in the rehabilitation of a cervical injury such

as those injuries to a cervical nerve root resulting in upper extremity weakness or a spinal cord injury with some degree of paraparesis or tetraparesis or post spinal fusion surgery. Use of such devices would be in a structured rehabilitation setting as part of a comprehensive rehabilitation program.

e. Fabrication/modification of orthotics, including splints, would be used when there is need to normalize weight-bearing, facilitate better motion response, stabilize a joint with insufficient muscle or proprioceptive/reflex competencies, to protect subacute conditions as needed during movement, and correct biomechanical problems. Orthotic/prosthetic training is the skilled instruction (preferably by qualified providers) in the proper use of orthotic devices and/or prosthetic limbs.

f. For information regarding specific types of orthotics/prosthetics/equipment, refer to individual medical treatment guidelines.

#### 15. Personality/Psychological/Psychiatric/ Psychosocial Intervention

a. Psychosocial treatment is a well-established therapeutic and diagnostic intervention with selected use in acute pain problems, and more widespread use in sub-acute and chronic pain populations. Psychosocial treatment is recommended as an important component in the total management of a patient with chronic pain and should be implemented as soon as the problem is identified.

b. Studies have noted that there is not a direct connection between impairment and disability nor is there a direct connection between lumbar imaging and pain. It appears that the lack of connections is likely accounted for by differences among individuals in level of depression, coping strategies, or other psychological distress.

c. There is some evidence that in the setting of chronic low back pain when disc pathology is present, a high degree of anxiety or depressive symptomatology is associated with relatively less pain relief in spite of higher opioid dosage than when these symptoms are absent. Therefore, psychological issues should always be screened for and treated in chronic pain patients.

d. Psychological treatments for pain can be conceptualized as having a neuropsychological basis. These treatments for pain have been shown to decrease physiological reactivity to stress, alter patterns of brain activation as demonstrated by functional MRI (fMRI), alter the volume of grey matter and other structures in the brain, and alter blood flow patterns in the brain. The most researched psychological treatment is Cognitive Behavioral Therapy (CBT) which is summarized in this Section.

e. The screening or diagnostic workup should have clarified and distinguished between pre-existing, aggravated, and/or purely causative psychological conditions. Therapeutic and diagnostic modalities include, but are not limited to, individual counseling, and group therapy. Treatment can occur within an individualized model, a multi-disciplinary model, or a structured pain management program.

f. A psychologist with a PhD, PsyD, EdD credentials, or a psychiatric MD/DO may perform psychosocial treatments. The following professionals may also perform treatment in consultation with a psychologist with a PhD, PsyD, EdD, or Psychiatric MD/DO: other licensed mental health providers, licensed health care providers with training in CBT, or providers certified as CBT therapists with experience in treating chronic pain disorders in injured workers.

g. If a diagnosis consistent with the standards of the American Psychiatric Association's Diagnostic and Statistical Manual of Mental Disorders (DSM) or most current ICD has been determined, the patient should be evaluated for the potential need for psychiatric medications. Use of any medication to treat a diagnosed condition may be ordered by an authorized treating physician or by either the consulting psychiatrist or medical psychologist. Visits for management of psychiatric medications are medical in nature and are not a component of psychosocial treatment. Therefore, separate visits for medication management may be necessary, depending on the patient and medications selected.

h. Psychosocial interventions include psychotherapeutic treatments for behavioral health conditions, as well as behavioral medicine treatments. These interventions may similarly be beneficial for patients without psychiatric conditions but who may need to make major life changes in order to cope with pain or adjust to disability. Examples of these treatments include Cognitive Behavioral Therapy (CBT), relaxation training, mindfulness training, and sleep hygiene psychoeducation.

i. CBT refers to a group of psychological therapies that are sometimes referred to by more specific names such as Rational Emotive Behavior Therapy, Rational Behavior Therapy, Rational Living Therapy, Cognitive Therapy, and Dialectic Behavior Therapy. Variations of CBT methods can be used to treat a variety of conditions, including chronic pain, depression, anxiety, phobias, and post-traumatic stress disorder (PTSD). For patients with multiple diagnoses, more than one type of CBT might be needed. The CBT used in research studies is often "manualized CBT," meaning that the treatment follows a specific protocol in a manual. In clinical settings, CBT may involve the use of standardized materials, but it is also commonly adapted by a psychologist or psychiatrist to the patient's unique circumstances. If the CBT is being performed by a non-mental health professional, a manual approach would be strongly recommended.

j. CBT must be distinguished from neuropsychological therapies used to teach compensatory strategies to brain injured patients, which are also called "cognitive therapy." Many other clinical providers also provide a spectrum of cognitive interventions including: motivational interviewing, pain neuroscience education, and other interventions aimed at patient education and change in behavior. Refer to Therapy-Active, for details.

k. It should be noted that most clinical trials on CBT exclude subjects who have significant psychiatric diagnoses. Consequently, the selection of patients for CBT should include the following considerations. CBT is instructive and structured, using an educational model with homework to teach inductive rational thinking. Because of this educational model, a certain level of cognitive ability and literacy is assumed for most CBT protocols. Patients who lack the cognitive and educational abilities required by a CBT protocol are unlikely to be successful. Further, given the highly structured nature of CBT, it is more effective when a patient's circumstances are relatively stable. For example, if a patient is about to be evicted, is actively suicidal, or is coming to sessions intoxicated, these matters will generally preempt CBT treatment for pain and require other types of psychotherapeutic response. Conversely, literate patients whose circumstances are relatively stable, but who catastrophize or cope poorly with pain or disability, are often good candidates for CBT for pain. Similarly, literate patients whose circumstances are relatively stable, but who exhibit unfounded medical phobias, are often good candidates for CBT for anxiety.

l. CBT is often combined with active therapy in an interdisciplinary program, whether formal or informal. It must be coordinated with a psychologist or psychiatrist. CBT can be done in a small group or individually, and the usual number of treatments varies between 8 and 16 sessions.

m. Before CBT or other psychological treatments are performed, the patient must have a full psychological evaluation. The CBT program must be done under the supervision of a psychologist with a PhD, PsyD, or EdD or a psychiatric MD/DO.

n. Psychological disorders associated with distress and dysfunction are common in chronic pain. One study demonstrated that the majority of patients who had failed other therapy and participated in an active therapy program also suffered from major depression. However, in a program that included CBT and other psychological counseling, the success rate for return to work was similar for those with and without an ICD diagnosis. This study further strengthens the argument for having some psychological intervention included in all chronic pain treatment plans.

o. Hypnosis

i. The term *hypnosis* can encompass a number of therapy types including relaxation, imagery, focused attention, interpersonal processing, and suggestion. Hypnosis has been used in depression and for distress related to medical procedures.

ii. A number of studies support the use of hypnosis for chronic pain management. At least one pilot study suggested that hypnotic cognitive therapy assists recovery in chronic pain. Other imaging studies support the concept that hypnosis can actively affect cortical areas associated with pain. Thus, this therapy may be used at the discretion of the psychologist. A more recent meta-analysis was completed which purported to show evidence for

hypnosis. However, the heterogeneity of the studies included prevents this study from meeting our standards for evidence.

iii. For all psychological/psychiatric interventions, an assessment and treatment plan must be provided to the treating physician prior to initiating treatment. The treatment plan must include specific, measurable, achievable, and realistic behavioral goals, with specific interventions and time frames to achieve those goals. The report should also address pertinent issues such as pre-existing, exacerbated or aggravated, and/or causative issues, as well as a realistic functional prognosis.

p. Time frames for cognitive behavioral therapy (CBT) or similar treatment:

i. time to produce effect: 12-16 hours of treatment (one hour individual sessions or alternately one to two hour group sessions);

ii. frequency: one to two times weekly for the first two weeks, decreasing to one time per week thereafter.

iii. maximum duration: 24 one hour sessions.

NOTE: Before CBT or other psychological/psychiatric interventions are done, the patient must have a full psychological evaluation. The CBT program must be done under the supervision of a psychologist with a PhD, PsyD, or EdD, or a Psychiatric MD/DO.

q. Time frames for other psychological/psychiatric interventions:

i. time to produce effect: six to eight weeks;

ii. frequency: one to two times weekly for the first two to four weeks (excluding hospitalization, if required), decreasing to one time per week for the second month. Thereafter, two to four times monthly with the exception of exacerbations, which may require increased frequency of visits. Not to include visits for medication management;

iii. optimum duration: two to six months;

iv. maximum duration: commonly six months for most cases. Extensions under conditions as noted below. (Not to include visits for medication management). For select patients (e.g., ongoing medical procedures or complications, medication dependence, diagnostic uncertainty, delays in care due to patient or systemic variables), less intensive but longer supervised psychological/psychiatric treatment may be required. If counseling beyond six months is indicated, the nature of the psychosocial risks being managed or functional progress must be documented. Progress notes for each appointment should include goal setting, with specific, measurable, achievable, and realistic goals, and a timetable with an expected end point. In complex cases, goal setting may include maintaining psychological equilibrium while undergoing invasive procedures.

#### 16. Restriction of Activities

a. Continuation of normal daily activities is the recommendation for most patients since immobility will negatively affect rehabilitation. Prolonged immobility results

in a wide range of deleterious effects, such as a reduction in aerobic capacity and conditioning, loss of muscle strength and flexibility, increased segmental stiffness, promotion of bone demineralization, impaired disc nutrition, and the facilitation of the illness role.

b. Some level of immobility may occasionally be appropriate which could include splinting/casting or as part of a structured schedule that includes energy conservation or intentional rest breaks between activities. While these interventions may have been ordered in the acute phase, the provider should be aware of their impact on the patient's ability to adequately comply with and successfully complete rehabilitation. Activity should be increased based on the improvement of core strengthening.

c. Patients should be educated regarding the detrimental effects of immobility versus the efficacious use of limited rest periods. Adequate rest allows the patient to comply with active treatment and benefit from the rehabilitation program. In addition, complete work cessation should be avoided, if possible, since it often further aggravates the pain presentation and promotes disability. Modified return-to-work is almost always more efficacious and rarely contraindicated in the vast majority of injured workers.

#### 17. Return-to-Work

a. Return to work and/or work-related activities whenever possible is one of the major components in treatment and rehabilitation. Return-to-work is a subject that should be addressed by each workers' compensation provider at the first meeting with the injured employee, and be updated at each additional visit. A return-to-work format should be part of a company's health plan, knowing that return-to-work can decrease anxiety, reduce the possibility of depression, and reconnect the worker with society.

b. A prolonged time off work is likely to lead to chronic disability. In complex cases, experienced nurse case managers may be required to assist in return-to-work. Other services, including psychological evaluation and/or treatment, jobsite analysis, and vocational assistance may be employed.

c. Two counseling sessions with an occupational physician, and work site visit if necessary, may be helpful for workers who are concerned about returning to work.

d. At least one study suggests that health status is worse for those patients who do not return to work than those who do. Self-employment and injury severity predict return to work. Difficulty with pain control, ADLs, and anxiety and depression were common among patients who did not return to work.

e. The following should be considered when attempting to return an injured worker with chronic pain to work.

i. Job History Interview. An authorized treating physician should perform a job history interview at the time of the initial evaluation and before any plan of treatment is

established. Documentation should include the workers' job demands, stressors, duties of current job, and duties of job at the time of the initial injury. In addition, cognitive and social issues should be identified and treatment of these issues should be incorporated into the plan of care.

ii. **Coordination of Care.** Management of the case is a significant part of return-to-work and may be the responsibility of an authorized treating physician, occupational health nurse, risk manager, or others. Case management is a method of communication between the primary provider, referral providers including occupational and physical therapists, insurer, employer, and employee. Because case management may be coordinated by a variety of professionals, the case manager should be identified in the medical record.

iii. **Communication** is essential between the patient, authorized treating physician, employer, and insurer. Employers should be contacted to verify employment status, job duties and demands, and policies regarding injured workers. In addition, availability of temporary and permanent restrictions, for what duration, as well as other placement options should be discussed and documented. All communications in the absence of the patient are required to be documented and made available to the patient.

iv. **Establishment of Return-To-Work Status.** Return-to-work for persons with chronic pain should be thought of as therapeutic, assuming that work is not likely to aggravate the basic problem or increase the discomfort. In some cases of chronic pain, the worker may not be currently working or even employed. The goal of return-to-work would be to return the worker to any level of employment with the current employer or to return them to any type of new employment. Temporary restrictions may be needed while recommended ergonomic or adaptive equipment is obtained; employers should obtain recommended equipment in a timely manner.

v. **Establishment of Activity Level Restrictions.** A formal job description for the injured worker is necessary to identify physical demands at work and assist in the creation of modified duty. A Job Site Evaluation may be utilized to identify tasks such as pushing, pulling, lifting, reaching, grasping, pinching, sitting, standing, posture, and ambulatory distance and terrain. If applicable, a job site evaluation may also be utilized to assess temperature, air flow, noise and the number of hours that may be worked per day in a specific environment. Also refer to Section, Jobsite Evaluation and Alterations. Due to the lack of predictability regarding exacerbation of symptoms affecting function, an extended, occupationally focused functional capacity evaluation may be necessary to determine the patient's tolerance for job type tasks over a continued period of time. Job requirements should be reviewed for the entire eight hours or more of the working day. When prescribing the FCE, the physician must assess the probability of return to work against the potential for exacerbation of the work related condition. Work restriction assigned by the authorized treating physician may be temporary or permanent. The case manager should continue to seek out

modified work until restrictions become less cumbersome or as the worker's condition improves or deteriorates. Ergonomic changes recommended by the worksite evaluation should be put in place.

(a). Between one and three days after the evaluation, there should be a follow-up evaluation by the treating therapist and/or an authorized treating physician to assess the patient's status. Patients should be encouraged to report their status post FCE.

vi. **Rehabilitation and Return-to-Work.** As part of rehabilitation, every attempt should be made to simulate work activities so that an authorized treating physician may promote adequate job performance. The use of ergonomic or adaptive equipment, therapeutic breaks, and interventional modalities at work may be necessary to maintain employment.

vii. **Vocational Assistance.** Formal vocational rehabilitation is a generally accepted intervention and can assist disabled persons to return to viable employment. Assisting patients to identify vocational goals will facilitate medical recovery and aid in the maintenance of MMI by 1) increasing motivation towards treatment and 2) alleviating the patient's emotional distress. Physically limited patients will benefit most if vocational assistance is provided during the interdisciplinary rehabilitation phase of treatment. To assess the patient's vocational capacity, a vocational assessment utilizing the information from occupational and physical therapy assessments may be performed. This vocational assessment may identify rehabilitation program goals, as well as optimize both patient motivation and utilization of rehabilitation resources. This may be extremely helpful in decreasing the patient's fear regarding an inability to earn a living, which can add to his/her anxiety and depression.

(a). **Recommendations to Employers and Employees of Small Businesses.** Employees of small businesses who are diagnosed with chronic pain may not be able to perform any jobs for which openings exist. Temporary employees may fill those slots while the employee functionally improves. Some small businesses hire other workers and if the injured employee returns to the job, the supervisor/owner may have an extra employee. Case managers may assist with resolution of these problems, and with finding modified job tasks, or jobs with reduced hours, etc., depending upon company philosophy and employee needs.

(b). **Recommendations to Employers and Employees of Mid-Sized and Large Businesses.** Employers are encouraged by the OWCA to identify modified work within the company that may be available to injured workers with chronic pain who are returning to work with temporary or permanent restrictions. To assist with temporary or permanent placement of the injured worker, it is suggested that a program be implemented that allows the case manager to access descriptions of all jobs within the organization.

## 18. Therapy—Active

a. The following active therapies are widely used and accepted methods of care for a variety of work-related injuries. Active therapy is based on the philosophy that therapeutic exercise and/or activity are beneficial for restoring flexibility, strength, endurance, function, range of motion, and can alleviate discomfort. All active therapy plans should be made directly with patients in the interest of achieving long-term individualized goals.

b. Active therapy requires an internal effort by the individual to complete a specific exercise or task. This form of therapy requires supervision from a therapist or medical provider such as verbal, visual, and/or tactile instruction(s). Active therapy is intended to promote independence and self-reliance in managing the physical pain as well as to improve the functional status in regard to the specific diagnosis, general conditioning and well-being. At times, a provider may help stabilize the patient or guide the movement pattern but the energy required to complete the task is predominately executed by the patient. Therapy in this Section should not be merely a repeat of previous therapy but should focus specifically on the individual goals and abilities of the patient with chronic pain.

c. The goal of active therapy is to teach the patient exercises that they can perform regularly on their own. Patients should be instructed to continue active therapies at home as an extension of the treatment process in order to maintain improvement levels. Follow-up visits to reinforce and monitor progress and proper technique are recommended. Home exercise can include exercise with or without mechanical assistance or resistance and functional activities with assistive devices.

d. On occasion, specific diagnoses and post-surgical conditions may warrant durations of treatment beyond those listed as “maximum.” Factors such as exacerbation of symptoms, re-injury, interrupted continuity of care, need for post-operative therapy, and co-morbidities may also extend durations of care. Interventional injections require postoperative active therapy coupled with home exercise to improve function, with a reset of the recommended number of sessions, regardless of the number of therapy visits previously conducted. Specific goals with objectively measured functional improvement during treatment must be cited to justify extended durations of care. It is recommended that, if no functional gain is observed after the number of treatments under “time to produce effect” has been completed, then alternative treatment interventions, further diagnostic studies, or further consultations should be pursued.

e. Pain Neuroscience Education (PNE): an educational strategy used by physical therapists and other practitioners that focuses on teaching people in pain more about the neurobiological and neurophysiological processes involved in their pain experience, versus a focus on anatomical and pathoanatomical education. PNE helps patients develop an understanding of various pain processes including central sensitization, peripheral sensitization, inhibition, facilitation, the brain’s processing of threat appraisal, and various biological systems involved in a pain

experience. This reconceptualization of pain via PNE is then combined with various behavioral strategies including aerobic exercise, pacing, graded exposure, graded activity, and goal setting. PNE is likely to positively influence pain ratings, disability, fear-avoidance behaviors, pain catastrophization, and limitations in movement, pain knowledge, and healthcare utilization. PNE is recommended with active therapy for chronic pain patients.

f. The following active therapies are listed in alphabetical order.

i. Activities of daily living (ADL) are well-established interventions which involve instruction, active-assisted training, and/or adaptation of activities or equipment to improve a person's capacity in normal daily activities such as self-care, work re-integration training, homemaking, and driving:

- (a). time to produce effect: four to five treatments;
- (b). frequency: one to five times per week;
- (c). optimum duration: four to six weeks;
- (d). maximum duration: six weeks.

ii. Aquatic therapy is a well-accepted treatment which consists of the therapeutic use of aquatic immersion for therapeutic exercise to promote strengthening, core stabilization, endurance, range-of-motion, flexibility, body mechanics, and pain management. Aquatic Therapy is the implementation of active therapeutic procedures (individual or group) in a swimming or therapeutic pool heated to 88 to 92 degrees. The water provides a buoyancy force that lessens the amount of force of gravity applied to the body, and the pool should be large enough to allow full extremity range of motion and full erect posture. The decreased gravity effect allows the patient to have a mechanical advantage and more likely have a successful trial of therapeutic exercise. Aquatic vests, belts and other devices can be used to provide stability, balance, buoyancy, and resistance. In addition, the compression of the water against the affected extremity and ability to move easier with decreased gravity allow for resulting muscular compression against vessels improving lymphatic drainage resulting in decreased edema. Aquatic Therapy may also provide an additional stimulus to assist with desensitization.

(a). There is good evidence that aquatic exercise and land-based exercise show comparable outcomes for function and mobility among people with symptomatic osteoarthritis of the knee or hip.

(b). Indications. The therapy may be indicated for individuals who:

- (i). cannot tolerate active land-based or full-weight bearing therapeutic procedures;
- (ii). require increased support in the presence of proprioceptive deficit;
- (iii). are at risk of compression fracture due to decreased bone density;

(iv).have symptoms that are exacerbated in a dry environment;

(v). have a higher probability of meeting active therapeutic goals than in a dry environment.

(c). Time frames for aquatic therapy:

(i). time to produce effect: four to five treatments;

(ii). frequency: three to five times per week;

(iii).optimum duration: four to six weeks;

(iv).maximum duration: six weeks.

(d). After the supervised aquatics program has been established, either a self-directed aquatic program or a transition to a self-directed dry environment exercise program is recommended.

iii. Functional activities are well-established interventions which involve the use of therapeutic activity to enhance mobility, body mechanics, employability, coordination, and sensory motor integration:

(a). time to produce effect: four to five treatments;

(b). frequency: one to five times per week;

(c). optimum duration: four to six weeks;

(d). maximum duration: eight weeks.

iv. Functional electrical stimulation is an accepted treatment in which the application of electrical current to elicit involuntary or assisted contractions of atrophied and/or impaired muscles. Indications include muscle atrophy, weakness, and sluggish muscle contraction secondary to pain, injury, neuromuscular dysfunction, peripheral nerve lesion, or radicular symptoms. This modality may be prescribed for use at home when patients have demonstrated knowledge of how to self-administer and are in an independent exercise program:

(a). time to produce effect: two to six treatments;

(b). frequency: three times per week;

(c). optimum duration: eight weeks;

(d). maximum duration: eight weeks. if beneficial, provide with home unit.

v. Neuromuscular re-education is a generally accepted treatment. It is the skilled application of exercise with manual, mechanical, or electrical facilitation to enhance strength, movement patterns, neuromuscular response, proprioception, kinesthetic sense, coordination, education of movement, balance and posture.

(a). There is some evidence that there is a modest benefit from adding a back school to other treatments such as NSAIDs, massage, transcutaneous electrical nerve stimulation (TENS), and other physical therapy modalities. However, a recent adequate quality

systematic review found no evidence for the effectiveness of back schools for treating chronic low back pain.

(b). Indications include the need to promote neuromuscular responses through carefully timed proprioceptive stimuli, to elicit and improve motor activity in patterns similar to normal neurologically developed sequences, and improve neuromotor response with independent control.

(c). Time frames for neuromuscular re-education:

(i). time to produce effect: two to six treatments;

(ii). frequency: one to three times per week;

(iii).optimum duration: four to eight weeks;

(iv).maximum duration: eight weeks.

vi. Spinal stabilization is a generally well-accepted treatment. The goal of this therapeutic program is to strengthen the spine in its neutral and anatomic position. The stabilization is dynamic which allows whole body movements while maintaining a stabilized spine. It is the ability to move and function normally through postures and activities without creating undue vertebral stress.

(a). Time frames for spinal stabilization:

(i). time to produce effect: four to eight treatments;

(ii). frequency: one to three times per week;

(iii).optimum duration: four to eight weeks;

(iv).maximum duration: eight weeks.

vii. Therapeutic exercise with or without mechanical assistance or resistance, may include isoinertial, isotonic, isometric and isokinetic types of exercises. May also include alternative/complementary exercise movement therapy (with oversight of a physician or physical therapist).

(a). Indications include the need for cardiovascular fitness, reduced edema, improved muscle strength, improved connective tissue strength and integrity, increased bone density, promotion of circulation to enhance soft tissue healing, improvement of muscle recruitment, improved proprioception, and coordination, and increased range of motion are used to promote normal movement patterns.

(b). Yoga may be an option for motivated patients with appropriate diagnoses.

(c). Therapeutic exercise programs should be tissue specific to the injury and address general functional deficits as identified in the diagnosis and clinical assessment. Patients should be instructed in and receive a home exercise program that is progressed as their functional status improves. Upon discharge, the patient would be independent in the performance of the home exercise program and would have been educated in the importance of continuing such a program. Educational goals would be to maintain or further

improve function and to minimize the risk for aggravation of symptoms in the future.

(d). Available evidence supporting therapy mainly exists in the chronic low back literature.

(e). Time frames for therapeutic exercise:

(i). time to produce effect: two to six treatments;

(ii). frequency: two to five times per week;

(iii). optimum duration: four to eight weeks and concurrent with an active daily home exercise program;

(iv). maximum duration: 8 to 12 weeks of therapist oversight. Home exercise should continue indefinitely. Additional sessions may be warranted during periods of exacerbation of symptoms.

(f). Time frames for yoga:

(i). time to produce effect: eight sessions;

(ii). maximum duration: 48 sessions are the maximum expected duration.

viii. Work Conditioning. These programs are work-related, outcome-focused, individualized treatment programs. Objectives of the program includes, but are not limited to, improvement of cardiopulmonary and neuromusculoskeletal functions (strength, endurance, movement, flexibility, postural control, and motor control functions), patient education, and symptom relief. The goal is for patients to gain full- or optimal- function and return to work. The service may include the time-limited use of modalities, both active and passive, in conjunction with therapeutic exercise, functional activities, general conditioning body mechanics and lifting techniques re-training. These programs are usually initiated once re-conditioning has been completed but may be offered at any time throughout the recovery phase. It should be initiated when imminent return of a patient to modified- or full-duty is not an option, but the prognosis for returning the patient to work at completion of the program is at least fair to good:

(a). length of visit: two to four hours per day;

(b). frequency: two to five visits per week;

(c). optimum duration: two to four weeks;

(d). maximum duration: six weeks. Participation in a program beyond six weeks must be documented with respect to need and the ability to facilitate positive symptomatic or functional gains.

ix. Work Simulation. Work simulation is a program where an individual completes specific work-related tasks for a particular job and return to work. Use of this program is appropriate when modified duty can only be partially accommodated in the work place, when modified duty in the work place is unavailable, or when the patient requires more structured supervision. The need for work place simulation should be based upon the results of a functional capacity evaluation and/or jobsite analysis:

(a). length of visit: two to six hours per day;

(b). frequency: two to five visits per week;

(c). optimum duration: two to four weeks;

(d). maximum duration: six weeks. Participation in a program beyond six weeks must be documented with respect to need and the ability to facilitate positive symptomatic or functional gains.

#### 19. Therapy—Passive

a. Most of the following passive therapies and modalities are generally accepted methods of care for a variety of work-related injuries. Passive therapy includes those treatment modalities that do not require energy expenditure on the part of the patient. They are principally effective during the early phases of treatment and are directed at controlling symptoms such as pain, inflammation and swelling and to improve the rate of healing soft tissue injuries. They should be used adjunctively with active therapies such as postural stabilization and exercise programs to help control swelling, pain and inflammation during the active rehabilitation process. They may be used intermittently as a licensed practitioner deems appropriate, or regularly if there are episodes of acute pain superimposed upon a chronic pain problem.

b. On occasion, specific diagnoses and post-surgical conditions may warrant durations of treatment beyond those listed as "maximum." Factors such as exacerbation of symptoms, re-injury, interrupted continuity of care and comorbidities may extend durations of care. Having specific goals with objectively measured functional improvement during treatment can support extended durations of care. It is recommended that if after six to eight visits no treatment effect is observed, alternative treatment interventions, further diagnostic studies or further consultations should be pursued.

c. The following passive therapies are listed in alphabetical order.

i. Electrical Stimulation (Unattended): low frequency transcutaneous muscle stimulator. Electrical stimulation, once applied, requires minimal on-site supervision by the licensed practitioner. Indications include pain, inflammation, muscle spasm, atrophy, decreased circulation, and the need for osteogenic stimulation. A home unit may be purchased or rented if treatment is effective and frequent use is recommended:

(a). time to produce effect: two to four treatments;

(b). frequency: varies, depending upon indication, between two to three times per day to one time week;

(c). optimum/maximum duration: four treatments for clinic use.

ii. Iontophoresis is an accepted treatment which consists of the transfer of medication into superficial tissue, including, but not limited to, steroidal anti-inflammatories

and anesthetics, through the use of electrical stimulation. Indications include pain (lidocaine), inflammation (hydrocortisone, salicylate, dexamethasone sodium phosphate), edema (mecholyly, hyaluronidase, salicylate), ischemia (magnesium, mecholyly, iodine), muscle spasm (magnesium, calcium), calcific deposits (acetate), scars and keloids (chlorine, iodine, acetate):

(a). time to produce effect: two to four treatments;

(b). frequency: three times per week with at least 48 hours between treatments;

(c). optimum duration: four to six weeks;

(d). maximum duration: six weeks.

iii. Low Level Laser. Not recommended as there is no proven benefit for this intervention due to lack of studies of sufficient quality. There is not enough research at this time to support this modality in the treatment of chronic pain. Results of low level laser have been mixed and often of poor quality.

iv. *Manual treatment including manipulation* is defined as osteopathic manipulative treatment, chiropractic manipulative treatment, manual therapy, manipulation, or mobilization. Manual treatments may be applied by osteopathic physicians (DOs), chiropractors (DCs), physical therapists (PTs), occupational therapists (OTs), or medical doctors (MDs). Some popular and useful techniques include but are not limited to: high velocity, low amplitude (HVLA); muscle energy (ME) or hold-relax; strain-counterstrain (SCS); a balanced ligamentous tension (BLT); and myofascial release (MFR). Under these different types of manipulation, many subsets of different techniques that can be described as a) direct—a forceful engagement of a restrictive/pathologic barrier, b) indirect—a gentle/non-forceful disengagement of a restrictive/pathologic barrier, c) the patient actively assists in the treatment, and d) the patient relaxing, allowing the practitioner to move and balance the body tissues. When the proper diagnosis is made and coupled with the appropriate technique, manipulation has no contraindications and can be applied to all tissues of the body, including muscles, tendons, ligaments, joints, fascia, and viscera. This may consist of a variety of techniques. Pre-treatment assessment should be performed as part of each manual treatment visit to ensure that the correct diagnosis and correct treatment is employed.

(a). The decision to refer a patient for spinal manipulation rather than for other treatments should be made on the basis of patient preference and relative safety, not on an expectation of a greater treatment effect. It may be the first line of treatment, in combination with active therapy for some patients, and should strongly be considered for patients with positive provocative testing for SI joint dysfunction or facet dysfunction who are not recovering in the first few weeks.

(b). Contraindications to HVLA manipulation include joint instability, fractures, severe osteoporosis, infection, metastatic cancer, local primary bone tumor with

questionable osseous integrity, Paget's disease, active inflammatory arthritis, aortic aneurysm, and signs of progressive neurologic deficits.

(c). AHRQ supports use of spinal manipulation for chronic low back pain. In addition, based on multiple studies with some and good levels of evidence, there is good evidence supporting the use of manual therapy for treating chronic low back pain and chronic neck pain. There is also good evidence that supervised exercise therapy with added manual mobilization shows moderate, clinically important reductions in pain compared to non-exercise controls in people with osteoarthritis of the knee. There is not sufficient evidence to reliably determine whether manual muscle energy technique (MET) is likely to be effective in practice.

(d). Time frames for manual treatment including manipulation:

(i). time to produce effect: six to nine treatments;

(ii). frequency: one to three times per week for the first two weeks as indicated by the severity of the condition. Treatment may continue at one treatment per week for the next six weeks;

(iii). optimum duration: four to six weeks;

(iv). maximum duration: eight weeks. At week eight, patients should be re-evaluated. Care beyond eight weeks may be indicated for certain chronic pain patients in whom manipulation is helpful in improving function, decreasing pain and improving quality of life. In these cases, treatment may be continued at one treatment every other week until the patient has reached MMI and maintenance treatments, using the accompanying post MMI guideline, have been determined. Refer to Maintenance Management section. Extended durations of care beyond what is considered “maximum” may be necessary in cases of re-injury, interrupted continuity of care, exacerbation of symptoms, and in those patients with comorbidities.

v. Manipulation under general anesthesia (MUA) refers to manual manipulation of the lumbar spine in combination with the use of a general anesthetic or conscious sedation. It is intended to improve the success of manipulation when pain, muscle spasm, guarding, and fibrosis appear to be limiting its application in patients otherwise suitable for their use.

(a). There have been no high quality studies to justify its benefits given the risks of general anesthetic and conscious sedation. It is not recommended.

vi. Manipulation under joint anesthesia (MUJA) refers to manipulation of the lumbar spine in combination with a fluoroscopically guided injection of anesthetic with or without corticosteroid agents into the facet joint at the level being manipulated.

(a). There are no controlled clinical trials to support its use. It is not recommended.



vii. **Massage—Manual or Mechanical.** Massage is manipulation of soft tissue with broad ranging relaxation and circulatory benefits. This may include stimulation of acupuncture points and acupuncture channels (acupressure), application of suction cups and techniques that include pressing, lifting, rubbing, pinching of soft tissues by or with the practitioners' hands. Indications include edema (peripheral or hard and non-pliable edema), muscle spasm, adhesions, the need to improve peripheral circulation and range-of-motion, or to increase muscle relaxation and flexibility prior to exercise:

- (a). time to produce effect: immediate;
- (b). frequency: one to two times per week;
- (c). optimum duration: six weeks;
- (d). maximum duration: two months.

viii. **Mobilization (Soft Tissue)** is a generally well-accepted treatment. Mobilization of soft tissue is the skilled application of muscle energy, strain/counter strain, myofascial release, manual trigger point release, and manual therapy techniques designed to improve or normalize movement patterns through the reduction of soft tissue pain and restrictions. Soft tissue mobilization can also use various instruments to assist the practitioner. These are typically labeled "instrument assisted soft-tissue techniques". These can be interactive with the patient participating or can be with the patient relaxing and letting the practitioner move the body tissues. Indications include muscle spasm around a joint, trigger points, adhesions, and neural compression. Mobilization should be accompanied by active therapy:

- (a). time to produce effect: six to nine treatments;
- (b). frequency: up to three times per week;
- (c). optimum duration: four to six weeks;
- (d). maximum Duration: six weeks.

ix. **Percutaneous Electrical Nerve Stimulation (PENS).** Needles are used to deliver low-voltage electrical current under the skin. Theoretically this therapy prevents pain signals traveling through small nerve fibers from reaching the brain, similar to the theory of TENS.

(a). There is good evidence that PENS produces improvement of pain and function compared to placebo; however, there is no evidence that the effect is prolonged after the initial three week treatment episode. There are no well-done studies that show PENS performs better than TENS for chronic pain patients. PENS is more invasive, requires a trained health care provider and has no clear long-term effect; therefore it is not generally recommended.

(b). Time frames for percutaneous electrical nerve stimulation (PENS):

- (i). time to produce effect: one to four treatments;
- (ii). frequency: two to three times per week;

(iii). optimum duration: nine sessions;

(iv). maximum duration: 12 sessions per year.

x. **Superficial heat and cold therapy** (including infrared therapy) is a generally accepted treatment. Superficial heat and cold are thermal agents applied in various manners that lowers or raises the body tissue temperature for the reduction of pain, inflammation, and/or effusion resulting from injury or induced by exercise. Includes application of heat just above the surface of the skin at acupuncture points. Indications include acute pain, edema and hemorrhage, need to increase pain threshold, reduce muscle spasm and promote stretching/flexibility. Cold and heat packs can be used at home as an extension of therapy in the clinic setting:

(a). time to produce effect: immediate;

(b). frequency: two to five times per week;

(c). optimum duration: three weeks as primary or intermittently as an adjunct to other therapeutic procedures up to two months;

(d). maximum duration: two months.

xi. **Traction—Manual** is an accepted treatment and an integral part of manual manipulation or joint mobilization. Indications include decreased joint space, muscle spasm around joints, and the need for increased synovial nutrition and response. Manual traction is contraindicated in patients with tumor, infection, fracture, or fracture dislocation:

(a). time to produce effect: one to three sessions;

(b). frequency: two to three times per week;

(c). optimum and maximum duration: one month.

xii. **Traction—Mechanical** is indicated for decreased joint space, muscle spasm around joints, and the need for increased synovial nutrition and response. Traction modalities are contraindicated in patients with tumor, infections, fracture, or fracture dislocation. Non-oscillating inversion traction methods are contraindicated in patients with glaucoma or hypertension.

(a). There is some evidence that mechanical traction, using specific, instrumented axial distraction technique, is not more effective than active graded therapy without mechanical traction. Therefore, mechanical traction is not recommended for chronic axial spine pain.

(b). Time frames for mechanical traction:

(i). time to produce effect: one to three sessions up to 30 minutes. If response is negative after three treatments, discontinue this modality;

(ii). frequency: two to three times per week;

(iii). optimum/maximum duration: one month.

xiii. **Transcutaneous electrical nerve stimulation (TENS)** should include least one instructional session for

proper application and use. Indications include muscle spasm, atrophy, and decreased circulation and pain control. Minimal TENS unit parameters should include pulse rate, pulse width and amplitude modulation.

(a). One double-blinded, placebo-controlled study, found that low frequency TENS induces analgesia which is detected on functional MRI with change in brain activity in multiple regions. There was no functional follow-up. High-frequency TENS may be more effective than low frequency for patients on opioids.

(b). Time frames for transcutaneous electrical nerve stimulation (TENS):

(i). time to produce effect: immediate;

(ii). frequency: variable;

(iii). optimum duration: three sessions. If beneficial, provide with home unit;

(iv). maximum duration: three sessions. Purchase if effective.

xiv. Dry Needling (DN) Description. DN is a skilled intervention performed by physical therapists (PTs) and Chiropractors (DCs) that utilizes a solid filament needle to penetrate the skin and underlying tissues to treat relevant muscular, neural, and other connective tissues for the evaluation and management of neuromusculoskeletal conditions, pain, movement impairments, and disability. The technique can be done with or without electrical stimulation. It has been used for tendinopathies, headaches and occipital neuralgia, plantar fasciitis, shoulder pain, lateral epicondylalgia, spinal pain, hip and knee pain. The goal of dry needling is to improve overall function and disability by decreasing pain and improving range-of-motion, strength, and/or muscle firing patterns. It is a technique that is utilized in conjunction with other physical therapy treatments including therapeutic exercise, manual therapy, stretching, neuromuscular re-education, postural education, and pain neuroscience education.

(a). Indications. Dry needling is indicated when myofascial trigger points are identified in muscles in conjunction with decreased range-of-motion, decreased strength, altered muscle firing patterns, and/or pain which negatively affect a patient's overall function.

(b). Complications. Potential but rare complications of dry needling include infection and pneumothorax. Severe pain on injection suggests the possibility of an intraneural injection, and the needle should be immediately repositioned.

(c). There is some evidence that the inclusion of two sessions of trigger point dry needling into a twice daily five-week exercise program was significantly more effective in improving shoulder pain-related disability than an exercise program alone at 3, 6, and 12 month follow-ups in people with chronic subacromial pain syndrome. Both interventions were equally effective in reducing pain over 12 months.

(d). There is some evidence that four sessions of trigger point deep dry needling with passive stretching over two weeks was significantly more effective in reducing neck pain and improving neck disability than passive stretching alone in the short-term and at six-month follow-up in people with chronic nonspecific neck pain.

(e). Based on a number of meta-analysis and systematic reviews, studies have shown some advantage for dry needling. However, there are also a number of studies with negative results. Because of the low quality of studies and heterogeneity, no form of evidence can be drawn from these reviews, which include a number of anatomic sites.

(f). Time frames for dry needling (DN):

(i). time to produce effect: three to six treatments;

(ii). frequency: one to three times per week;

(iii). optimum duration: one to two months;

(iv). maximum duration: 14 treatments within 6 months.

xv. Ultrasound (Including Phonophoresis) is an accepted treatment which uses sonic generators to deliver acoustic energy for therapeutic thermal and/or non-thermal soft tissue effects. Indications include scar tissue, adhesions, collagen fiber and muscle spasm, and the need to extend muscle tissue or accelerate the soft tissue healing. Ultrasound with electrical stimulation is concurrent delivery of electrical energy that involves dispersive electrode placement. Indications include muscle spasm, scar tissue, pain modulation and muscle facilitation. Phonophoresis is the transfer of medication through the use of sonic generators to the target tissue to control inflammation and pain.

(a). Phonophoresis is the transfer of medication to the target tissue to control inflammation and pain through the use of sonic generators. These topical medications include, but are not limited to, steroidal anti-inflammatory and anesthetics.

(b). There is no high quality evidence to support the use of ultrasound for improving pain or quality of life in patients with non-specific chronic low back pain.

(c). Time frames for ultrasound (including phonophoresis):

(i). time to produce effect: one to four treatments;

(ii). frequency: one to two treatments per week;

(iii). optimum duration: four to six treatments;

(iv). maximum duration: eight treatments.

xvi. Vertebral Axial Decompression (VAX-D)/DRX, 9000: motorized traction devices which purport to produce non-surgical disc decompression by creating

negative intradiscal pressure in the disc space include devices with the trade names of VAX-D and DRX 9000.

(a). There are no good studies to support their use. They are not recommended.

AUTHORITY NOTE: Promulgated in accordance with R.S. 23:1203.1.

HISTORICAL NOTE: Promulgated by the Louisiana Workforce Commission, Office of Workers Compensation Administration, LR 37:1692 (June 2011), amended LR 46:205 (February 2020), repromulgated LR 46:365 (March 2020), LR 46:797 (June 2020), LR 46:797 (June 2020).

### **§2113. Therapeutic Procedures—Operative**

A. When considering operative intervention in chronic pain management, the treating physician must carefully consider the inherent risk and benefit of the procedure. All operative intervention should be based on a positive correlation with clinical findings, the clinical course, and diagnostic tests. A comprehensive assessment of these factors should have led to a specific diagnosis with positive identification of the pathologic condition. Operative treatment is indicated when the natural history of surgically treated lesions is better than the natural history for non-operatively treated lesions.

1. Surgical procedures are seldom meant to be curative and should be employed in conjunction with other treatment modalities for maximum functional benefit. Functional benefit should be objectively measured and includes the following:

- a. return-to-work or maintaining work status;
- b. fewer restrictions at work or performing activities of daily living (ADLs);
- c. decrease in usage of medications prescribed for the work-related injury;
- d. measurable functional gains, such as increased range-of-motion or documented increase in strength;

2. Education of the patient should include the proposed goals of the surgery, expected gains, risks or complications, and alternative treatment.

3. Smoking may affect soft tissue healing through tissue hypoxia. Patients should be strongly encouraged to stop smoking and be provided with appropriate counseling by the physician. If a treating physician recommends a specific smoking cessation program peri-operatively, this should be covered by the insurer. Physicians may monitor smoking cessation with laboratory tests such as cotinine levels. The surgeon will make the final determination as to whether smoking cessation is required prior to surgery. Similarly, patients with uncontrolled diabetes are at increased risk of post-operative infection and poor wound healing. It is recommended that routine lab work prior to any surgical intervention include a hemoglobin A1c. If it is higher than the recommended range, the surgery should be postponed until optimization of blood sugars has been achieved.

4. Prior to surgical intervention, the patient and treating physician should identify functional operative goals and the likelihood of achieving improved ability to perform activities of daily living or work activities, and the patient should agree to comply with the pre- and post-operative treatment plan including home exercise. The provider should be especially careful to make sure the patient understands the amount of post-operative therapy required and the length of partial- and full-disability expected post-operatively.

5. Monitored anesthesia care is acceptable for diagnostic and therapeutic procedures.

#### 6. Neurostimulation

a. Description—Spinal cord stimulation (SCS) is the delivery of low-voltage electrical stimulation to the spinal cord or peripheral nerves to inhibit or block the sensation of pain. The system uses implanted electrical leads and a battery powered implanted pulse generator (IPG).

b. There is some evidence that SCS is superior to reoperation in the setting of persistent radicular pain after lumbosacral spine surgery, and there is some evidence that SCS is superior to conventional medical management in the same setting. Success was defined as achieving 50 percent or more pain relief. However, the study could not demonstrate increased return to work. Some functional gains have been demonstrated. These findings may persist at three years of follow-up in patients who had an excellent initial response and who are highly motivated.

c. There is some evidence that a higher-frequency, 500Hz to 10 KHz spinal cord stimulator is more effective than a traditional low frequency 50 Hz stimulator in reducing both back pain and leg pain in patients who have had a successful trial of an external stimulator. Two-thirds of the patients had radiculopathy and one-half had predominant back pain. The higher frequency device appears to lead to greater patient satisfaction than the low frequency device, which is likely to be related to the fact that the higher frequency device does not produce paresthesias in order to produce a pain response. In contrast to the low frequency stimulator, which requires recharging about twice per month, the higher frequency stimulator is recommended for every one to three days recharging for 0.5 to 3 hours. A United Kingdom study of cost effectiveness for high frequency spinal cord stimulators found high cost effectiveness compared to traditional non-rechargeable or rechargeable stimulators, re-operation, or medical management.

d. Some evidence shows that SCS is superior to re-operation and conventional medical management for severely disabled patients who have failed conventional treatment and have Complex Regional Pain Syndrome (CRPS I) or failed back surgery with persistent radicular neuropathic pain.

e. A recent randomized trial found that patients with spinal cord stimulators for CRPS preferred different types and levels of stimulation for pain relief. No difference was found between 40,500Hz, 1200 Hz, and 10KHz levels or burst stimulation.

f. SCS can be used for patients who have CRPS II. Spinal cord stimulation for spinal axial pain has traditionally not been very successful. Recent technological advances such as higher frequency and burst stimulation have demonstrated better results for axial spine pain. These technologically superior spinal cord stimulators are recommended for axial spine pain.

g. SCS may be most effective in patients with CRPS I or II who have not achieved relief with oral medications, rehabilitation therapy, or therapeutic nerve blocks, and in whom the pain has persisted for longer than six months.

h. It is particularly important that patients meet all of the indications before a permanent neurostimulator is placed because several studies have shown that workers' compensation patients are less likely to gain significant relief than other patients. As of the time of this guideline writing, spinal cord stimulation devices have been FDA approved as an aid in the management of chronic intractable pain of the trunk and/or limbs, including unilateral and bilateral pain associated with the following: failed back surgery syndrome, intractable low back pain, leg pain and arm pain.

i. Particular technical expertise is required to perform this procedure and is available in some neurosurgical, rehabilitation, and anesthesiology training programs and fellowships. Physicians performing this procedure must be trained in neurostimulation implantation and participate in ongoing training workshops on this subject, such as those sponsored by the American Society of Interventional Pain Practitioners (ASIPP), North American Neuromodulation Society (NANS), or as sponsored by implant manufacturers. Permanent electrical lead and IPG placement should be performed by surgeons (orthopedic or neurosurgery) with fellowship training in spine based surgical interventions or other physicians who have completed an Accreditation Council for Graduate Medical Education (ACGME) accredited pain medicine fellowship or training and have completed the required number of supervised implantations during fellowship or training.

j. Complications—Serious, less common complications include spinal cord compression, paraplegia, epidural hematoma, epidural hemorrhage, undesirable change in stimulation, seroma, CSF leakage, infection, erosion, allergic response. Other complications consist of dural puncture, hardware malfunction or equipment migration, pain at implantation site, loss of pain relief, chest wall stimulation, and other surgical risks. In recent studies, device complication rates have been reported to be 25 percent at six months, 32 percent at 12 months, and 45 percent at 24 months. The most frequent complications are reported to be electrode migration (14 percent) and loss of paresthesia (12 percent), up to 24 percent required additional surgery. In a recent review of spinal stimulation, 34.6 percent of all patients reported a complication, most of them being technical equipment-related issues or undesirable stimulation.

k. Surgical Indications—Patients with established CRPS I or II, or radicular or trunk pain, or a failed spinal surgery with persistent functionally limiting radicular pain greater than axial pain, who have failed conservative therapy including active and/or passive therapy, pre-stimulator trial psychiatric evaluation and treatment, medication management, or therapeutic injections. Traditional SCS is not recommended for patients with the major limiting factor of persistent axial spine pain. Higher frequency stimulators may be used for patients with predominantly axial back pain or trunk pain. Traditional or other SCS may be indicated in a subset of patients who have a clear neuropathic radicular pain (radiculitis) with or without previous surgery. The extremity pain should account for at least 50 percent or greater of the overall back and leg pain experienced by the patient. Prior authorization is required. Habituation to opioid analgesics in the absence of a history of addictive behavior does not preclude the use of SCS. Patients with severe psychiatric disorders, issues of secondary gain, and one or more primary risk factors are not candidates for the procedure. The prognosis worsens as the number of secondary risk factors increases. Approximately, one third to one half of patients who qualify for SCS can expect a substantial long-lasting pain relief; however, it may not influence allodynia and hypesthesia. Patients' expectations need to be realistic, and therefore, patients should understand that the SCS intervention is not a cure for their pain but rather a masking of their symptomatology which might regress over time. There appears to be a likely benefit of up to three years, although some practitioners have seen benefits persist for longer periods.

i. Prior to surgical intervention, the patient and treating physician should identify functional operative goals and the likelihood of achieving improved ability to perform activities of daily living or work, as well as possible complications. The patient should agree to comply with the pre- and post-operative treatment plan including home exercise. The provider should be especially careful to make sure the patient understands the amount of post-operative therapy required and the length of partial- and full-disability expected post-operatively.

ii. Informed decision making should be documented for all invasive procedures. This must include a thorough discussion of the pros and cons of the procedure and the possible complications as well as the natural history of the identified diagnosis. Since many patients with the most common conditions will improve significantly over time, without invasive interventions, patients must be able to make well-informed decisions regarding their treatment.

iii. Smoking may affect soft tissue healing through tissue hypoxia. Patients should be strongly encouraged to stop smoking and be provided with appropriate counseling by the physician. If a treating physician recommends a specific smoking cessation program perioperative, this should be covered by the insurer. Typically the patient should show some progress toward cessation at about six weeks. Physicians may monitor smoking cessation with laboratory tests such as cotinine levels. The surgeon will

make the final determination as to whether smoking cessation is required prior to surgery. Patients with demonstrated success may continue the program up to three months or longer if needed based on the operative procedure. Smoking cessation should continue throughout the post-operative period. Refer to Smoking Cessation Medications and Treatment for further details.

iv. Patients must meet the following criteria in order to be considered candidates for neurostimulation:

(a). Traditional or other SCS may be indicated in a subset of patients who have a clear neuropathic or radicular pain (radiculitis) or trunk pain; are not candidates for surgical intervention on the spine; have burning pain in a distribution amenable to stimulation coverage and have pain at night not relieved by position. The extremity pain should account for at least 50 percent or greater of the overall arm or leg and back pain experienced by the patient. Higher frequency stimulators may be used for patients with predominantly axial back pain.

(b). Prior to the stimulator trial, a comprehensive psychiatric or psychological evaluation, and a chronic pain evaluation. Refer to Personality/Psychological Evaluation for Pain Management, for more information. This evaluation should include a standardized detailed personality inventory with validity scales (e.g., MMPI-2, MMPI-2-RF, or PAD); pain inventory with validity measures (e.g., BHI 2, MBMD); clinical interview and complete review of the medical records. The psychologist or psychiatrist performing these evaluations should not be an employee of the physician performing the implantation. This evaluation must be completed, with favorable findings, before the screening trial is scheduled. Before proceeding to a spinal stimulator trial, the evaluation should find the following:

- (i). no indication of falsifying information;
- (ii). no indication of invalid results on testing;

and

(iii).no primary psychiatric risk factors or “red flags” (e.g., psychosis, active suicidality, severe depression, or addiction). (Note that tolerance and dependence to opioid analgesics are not addictive behaviors and do not preclude implantation); and

(iv).a level of secondary risk actors or “yellow flags” (e.g., moderate depression, job dissatisfaction, dysfunctional pain conditions) judged to be below the threshold for compromising the patient’s ability to benefit from neurostimulation;

(v). the patient is cognitively capable of understanding and operating the neurostimulation control device; and

(vi).the patient is cognitively capable of understanding and appreciating the risks and benefits of the procedure; and

(vii). the patient is familiar with the implications of having an implant, can accept the

complications, potential disfigurement, and effort it takes to maintain the device; and

(viii). the patient is cognitively capable of understanding the course of injury both with and without neurostimulation; and

(ix).the patient has demonstrated a history of motivation in and adherence to prescribed treatments; and

(x). the patient understands the work related restrictions that may occur with placement of the stimulator. All reasonable surgical and non-surgical treatment has been exhausted; and

(xi).the topography of pain and its underlying pathophysiology are amenable to stimulation coverage (the entire painful area has been covered); and

(xii). a successful neurostimulation screening test of at least three to seven days for a percutaneous trial or 7 to 10 days for an open surgically implanted trial lead.

(c). For a spinal cord neurostimulation screening test, a temporary lead is either implanted surgically with an incision or percutaneously attached to the skin and attached to an external source to validate therapy effectiveness. A screening test is considered successful if the patient meets both of the following criteria: (a) experiences a 50 percent decrease radicular or CRPS in pain, which may be confirmed by visual analogue scale (VAS) or Numerical Rating Scale (NRS), and (b) demonstrates objective functional gains or decreased utilization of pain medications.

(i). Objective, measurable, functional gains must be evaluated by the primary treating physician prior to and before discontinuation of the trial. If the trial is with a surgically implanted lead below the skin, then the trial is from 7 to 10 days. If the trial is percutaneous, then the trial is three to seven days. Functional gains may include: standing, walking, positional tolerance, upper extremity activities, increased social participation, or decreased medication use.

1. Contraindications

i. unsuccessful SCS test—inability to obtain objective, documented, functional improvement or reduction of pain;

ii. those with cardiac pacemakers should be evaluated on an individual basis as some may qualify for surgery;

iii. patients who are unable to properly operate the system;

iv. patients who are anti-coagulated and cannot be without anticoagulation for a few days (e.g., patients with artificial heart valves);

v. patients with frequent severe infections;

vi. patients for whom a future MRI is planned unless the manufacturer has approval for the body part that will be the subject of the MRI.

m. Operative Treatment—Implantation of stimulating lead or leads connected by extensions to either an implanted neurostimulator or an implanted receiver powered by an external transmitter. The procedure may be performed either as an open or a percutaneous procedure, depending on the presence of epidural fibrosis and the anatomical placement required for optimal efficacy. During the final procedure for non-high frequency devices or for those without surgically implanted trial leads, the patient must be awakened to establish full coverage from the placement of the lead. One of the most common failures is misplaced leads. Functional improvement is anticipated for up to three years or longer when objective functional improvement has been observed during the time of neurostimulation screening exam.

n. Post-Operative Considerations

i. MRI may be contraindicated depending on the model and implant location.

ii. Work restrictions postplacement include no driving when active paresthesias are present. This does not apply to higher frequency stimulators as no paresthesia is present. Thus, use of potentially dangerous or heavy equipment while the lower frequency simulator is active is prohibited. The physician may also limit heavy physical labor to prevent lead dislodgement.

o. Post-Operative Therapy—Active and/or passive therapy should be employed to improve function. Implantable stimulators will require frequent monitoring such as adjustment of the unit and replacement of implanted batteries. Estimated battery life of SCS implantable devices is usually 5 to 10 years depending on the manufacturer.

7. Dorsal Root Ganglion Stimulator (See Neurostimulation)

8. Peripheral Nerve Stimulation—This modality should only be employed with a clear nerve injury or when the majority of pain is clearly in a nerve distribution in patients who have completed six months of other appropriate therapy including the same pre-trial psychosocial evaluation and treatment as are recommended for spinal cord stimulation. A screening trial should take place over three to seven days and is considered successful if the patient meets both of the following criteria:

a. experiences a 50 percent decrease in pain, which may be confirmed by Visual Analogue Scale (VAS) or Numerical Rating Scale (NRS); and

b. demonstrates objective functional gains or decreased utilization of pain medications. It may be used for proven occipital, ulnar, median, and other isolated nerve injuries.

9. Intrathecal drug delivery—recommended in patients in whom other conservative measures have failed or in those requiring high dose oral opiates or experiencing side effects to control pain or in cases of spasticity or uncontrolled muscle spasms. Oral pain medication would not be appropriate for chronic pain in conjunction with an

Intrathecal pain pump, except for up to the initial ten days after implant for purpose of postop incisional pain or weaning and stopping oral opiates. Treatment for concomitant acute pain separate from chronic pain can combine oral opiates and pump medication at reduced doses orally. Pumps require refilling every one to six months for the life of the patient. More than one medication may be needed in the pump. Once implanted the managing physician must arrange for continuity of care for refills and or pump adjustments. Oral opiates should be stopped 7-10 days after implantation or pump and Intrathecal catheter and pump should be titrated to control chronic pain. A PTM (Patient therapy manager) may be used for breakthrough pain. Acute pain may be treated concomitantly with short courses or oral opiates. Intrathecal pumps may be considered when dystonia and spasticity are dominant features or when pain is not able to be managed using any other non-operative treatment or in cases inadequate opiate management by other routes. Specific brands of infusion systems have been FDA approved for the following: chronic intraspinal (epidural and intrathecal) infusion of preservative-free morphine sulfate sterile solution in the treatment of chronic intractable pain, chronic infusion of preservative-free ziconotide sterile solution for the management of severe chronic pain, and chronic intrathecal infusion of baclofen for the management of severe spasticity. Other medications commonly used and acceptable in the pump as defined in the The Polyanalgesic Consensus Conference (PACC) Recommendations on Intrathecal Drug Infusion Systems Best Practices and Guidelines 2017 Tim Deer et al “Neuromodulation: Technology at the Neural Interface”.

a. Due to lack of proven efficacy and safety, the following medications are not recommended: magnesium, benzodiazepines, neostigmine, tramadol, and ketamine.

b. Description. This mode of therapy delivers small doses of medications directly into the cerebrospinal fluid.

c. Complications. Intrathecal delivery is associated with significant complications, such as infection, catheter disconnects, CSF leak, arachnoiditis, pump failure, nerve injury, and paralysis.

i. Typical adverse events reported with opioids (i.e., respiratory depression, tolerance, and dependence) or spinal catheter-tip granulomas that might arise during intrathecal morphine or hydromorphone treatment have not currently been recorded for ziconotide. The most common presentation of an intraspinal mass is a sudden increase in dosage required for pain relief, with new neurologic defects secondary to a mass effect. Technical errors can lead to drug overdose which can be life-threatening. Withdrawal or death can occur if pump refill is denied or prevented.

ii. Surveys have shown technical problems requiring surgical correction in 18 percent to 40 percent of patients. CSF leakage may occur with multiple dural punctures since the needle is larger than the spinal catheter. Follow PACC guidelines on efficacy. The function of the pump depends on its electronic power source, which may be disrupted by the magnet of an MRI; therefore, after the

patient has an MRI, the pump should be checked immediately after the MRI to ensure that it does not need to be restarted. The delivery rate can be affected by atmospheric pressure and body temperature. Some pumps are recommended to be emptied before the MRI and refilled immediately after the MRI.

d. Indications. Clinical studies are conflicting, regarding long-term, effective pain relief in patients with non-malignant pain. This treatment must be have preauthorization and the recommendation of at least one physician experienced in chronic pain management. The procedure should be performed by physicians with documented experience.

i. Prior to surgical intervention, the patient and treating physician should identify the possible functional operative goals and the likelihood of achieving improved ability to perform activities of daily living or work, as well as possible complications. The patient should agree to comply with the pre- and post-operative treatment plan including home exercise. The provider should be especially careful to make sure the patient understands the amount of post-operative therapy required and the length of partial- and full-disability expected post-operatively.

ii. Informed decision-making should be documented for all invasive procedures. This must include a thorough discussion of the pros and cons of the procedure and the possible complications as well as the natural history of the identified diagnosis. Since many patients with the most common conditions will improve significantly over time, without invasive interventions, patients must be able to make well-informed decisions regarding their treatment.

e. This small eligible sub-group of patients must meet all of the following indications:

i. a diagnosis of a specific physical condition known to be chronically painful has been made on the basis of objective findings; and

ii. all reasonable surgical and non-surgical treatment has been exhausted including failure of conservative therapy including active and/or passive therapy, medication management, or therapeutic injections; and

iii. pre-trial psychiatric or psychological evaluation has been performed (same as for SCS); and

iv. there is no evidence of current addictive behavior. (Tolerance and dependence to opioid analgesics are not addictive behaviors and do not preclude implantation.); and

v. it is recommended that patients be tapered off of opioids before the trial or keep on same dose and wean and stop within two weeks post implant or wean and stop two to three weeks before trial per PACC Guidelines for Trialing; and

vi. a successful trial of continuous infusion by a percutaneous spinal infusion pump for a minimum of 24 hours or by bolus infusion. A screening test is considered successful if the patient (a) experiences a 50 percent

decrease in pain, which may be confirmed by VAS, and (b) demonstrates objective functional gains or decreased utilization of other pain medications.

f. Contraindications. Infection, body size insufficient to support the size and weight of the implanted device. Patients with other implanted programmable devices should be given these pumps with caution since interference between devices may cause unintended changes in infusion rates.

10. Dorsal Nerve Root Resection: This procedure is not recommended. There exists the possibility of complications including unintended extensive nerve damage causing significant motor or sensibility changes from larger than anticipated lesioning of the ganglia at the dorsal ganglia level. For radio-frequency ablation refer to Radio Frequency Ablation—Dorsal Nerve Root Ganglion.

AUTHORITY NOTE: Promulgated in accordance with R.S. 23:1203.1.

HISTORICAL NOTE: Promulgated by the Louisiana Workforce Commission, Office of Workers Compensation Administration, LR 37:1711 (June 2011), amended LR 46:246 (February 2020), repromulgated LR 46:397 (March 2020), LR 50:693 (May 2024).

### **§2115. Maintenance Management**

A. Successful management of chronic pain conditions results in fewer relapses requiring intense medical care. Failure to address long-term management as part of the overall treatment program may lead to higher costs and greater dependence on the health care system. Management of CRPS and CPD continues after the patient has met the definition of maximum medical improvement (MMI). MMI is declared when a patient's condition has plateaued and the authorized treating physician believes no further medical intervention is likely to result in improved function. When the patient has reached MMI, a physician must describe in detail the maintenance treatment.

B. Maintenance care in CRPS and CPD requires a close working relationship between the carrier, the providers, and the patient. Providers and patients have an obligation to design a cost-effective, medically appropriate program that is predictable and allows the carrier to set aside appropriate reserves. Carriers and adjusters have an obligation to assure that medical providers can design medically appropriate programs. Designating a primary physician for maintenance management is strongly recommended.

C. Maintenance care will be based on principles of patient self-management. When developing a maintenance plan of care, the patient, physician and insurer should attempt to meet the following goals:

1. maximal independence will be achieved through the use of home exercise programs or exercise programs requiring special facilities (e.g., pool, health club) and educational programs;

2. modalities will emphasize self-management and self-applied treatment;

3. management of pain or injury exacerbations will emphasize initiation of active therapy techniques and may occasionally require anesthetic injection blocks;

4. dependence on treatment provided by practitioners other than an authorized treating physician will be minimized;

5. reassessment of the patient's function must occur regularly to maintain daily living activities and work function;

6. patients will understand that failure to comply with the elements of the self-management program or therapeutic plan of care may affect consideration of other interventions.

D. It is recommended that valid functional tests are used with treatments to track efficacy. The following are specific maintenance interventions and parameters.

1. Home Exercise Programs and Exercise Equipment. Most patients have the ability to participate in a home exercise program after completion of a supervised exercise rehabilitation program. Programs should incorporate an exercise prescription including the continuation of an age-adjusted and diagnosis-specific program for aerobic conditioning, flexibility, stabilization, and strength. Many patients will benefit from several booster sessions per year, which may include motivational interviewing and graded activity.

a. Some patients may benefit from the purchase or rental of equipment to maintain a home exercise program. Determination for the need of home equipment should be based on medical necessity to maintain MMI, compliance with an independent exercise program, and reasonable cost. Before the purchase or long-term rental of equipment, the patient should be able to demonstrate the proper use and effectiveness of the equipment. Effectiveness of equipment should be evaluated on its ability to improve or maintain functional areas related to activities of daily living or work activity. Prior to purchasing the equipment a physical therapist who has treated the patient may visit a facility with the patient to assure proper use of the equipment. Occasionally, compliance evaluations may be made through a four-week membership at a facility offering similar equipment. Home exercise programs are most effective when done three to five times a week.

2. Exercise Programs Requiring Special Facilities. Some patients may have higher compliance with an independent exercise program at a health club versus participation in a home program. All exercise programs completed through a health club facility should focus on the same parameters of an age-adjusted and diagnosis-specific program for aerobic conditioning, flexibility, stabilization, and strength. Selection of health club facilities should be limited to those able to track attendance and utilization, and provide records available for physician and insurer review. Prior to purchasing a membership, a physical therapist who has treated the patient may visit a facility with the patient to assure proper use of the equipment.

a. frequency: two to three times per week;

b. maximum maintenance duration: three months. Continuation beyond three months should be based on functional benefit and patient compliance. Health club membership should not extend beyond three months if attendance drops below two times per week on a regular basis.

3. Patient Education Management. Educational classes, sessions, or programs may be necessary to reinforce self-management techniques. This may be performed as formal or informal programs, either group or individual:

a. maintenance duration: two to six educational sessions during one 12-month period.

4. Psychological Management. An ideal maintenance program will emphasize management options implemented in the following order: individual self-management (pain control, relaxation and stress management, etc.); group counseling; individual counseling by a psychologist or psychiatrist; and in-patient treatment. Exacerbation of the injury may require psychological treatment to restore the patient to baseline. In those cases, use treatments and timeframe parameters listed in the Biofeedback and Psychological Evaluation or Intervention sections:

a. maintenance duration: 6 to 10 visits during the first year and four to six visits per year thereafter. In cases of significant exacerbation or complexity, refer to Section G.15, on psychological treatment.

5. Non-opioid Medication Management. In some cases, self-management of pain and injury exacerbations can be handled with medications, such as those listed in the Medication section. Physicians must follow patients who are on any chronic medication or prescription regimen for efficacy and side effects. Laboratory or other testing may be appropriate to monitor medication effects on organ function:

a. maintenance duration: usually, four medication reviews within a 12-month period. Frequency depends on the medications prescribed. Laboratory and other monitoring as appropriate.

6. Opioid Medication Management. In very selective cases, scheduled opioids or an implanted programmable pump with different medications including opioids may prove to be the most cost effective means of insuring the highest function and quality of life; however, inappropriate selection of these patients may result in a high degree of iatrogenic illness including addiction and drug overdose. A patient should have met the criteria in the opioids section of these guidelines before beginning maintenance opioids. Laboratory or other testing may be appropriate to monitor medication effects on organ function. The following management is suggested for maintenance opioids:

a. The medications should be clearly linked to improvement of function, not just pain control. All follow-up visits should document the patient's ability to perform routine functions satisfactorily. Examples include the abilities to perform: work tasks, drive safely, pay bills or perform basic math operations, remain alert and upright for 10 hours per day, or participate in normal family and social



activities. If the patient is not maintaining reasonable levels of activity the patient should usually be tapered from the opioid and tried on a different long-acting opioid.

b. A low risk opioid medication regimen is defined, as less than 50 MED per day. This may minimally increase or decrease over time. Dosages will need to be adjusted based on side effects of the medication and objective function of the patient. A patient may frequently be maintained on non- opioid medications to control side effects, treat mood disorders, or control neuropathic pain; however, only one long-acting opioid and one short-acting opioid for rescue use should be prescribed. Buccally absorbed opioids other than buprenorphine are not appropriate for these non-malignant pain patients. Transdermal opioid medications are not recommended, other than buprenorphine.

c. All patients on chronic opioid medication dosages need to sign an appropriate opioid contract with their physician for prescribing the opioids.

d. The patient must understand that continuation of the medication is contingent on their cooperation with the maintenance program. Use of non-prescribed drugs may result in tapering of the medication. The clinician should order random drug testing at least annually and when deemed appropriate to monitor medication compliance.

e. Patients on chronic opioid medication dosages must receive them through one prescribing physician:

i. maintenance duration: 12 visits within a 12-month period to review the opioid plan. Laboratory and other monitoring as appropriate.

7. Therapy Management. Some treatment may be helpful on a continued basis during maintenance care if the therapy maintains objective function and decreases medication use. With good management, exacerbations should be uncommon; not exceeding two times per year and using minimal or no treatment modality beyond self-management. On occasion, exacerbated conditions may warrant durations of treatment beyond those listed below. Having specific goals with objectively measured functional improvement during treatment can support extended durations of care. It is recommended that if after six to eight visits no treatment effect is observed, alternative treatment interventions should be pursued:

a. maintenance duration: Active Therapy, Acupuncture, or Manipulation: 10 visits [for each treatment] during the first year and then decreased to five visits per year thereafter.

## 8. Injection Therapy

a. Trigger Point Injections and Dry Needling. These injections or dry needling may occasionally be necessary to maintain function in those with myofascial problems:

i. maintenance duration for trigger point injections: not more than four injections per session not to exceed four sessions per 12-month period;

ii. maintenance duration for dry needling: no more than one to three times per week not to exceed 14 treatments within six months.

b. Epidural and Selective Nerve Root Injections. Patients who have experienced functional benefits from these injections in the past may require injection for exacerbations of the condition. Recall that the total steroid injections at all sites, including extremities, should be limited to 3-4 mg/kg per rolling 12 months to avoid side effects from steroids:

i. maintenance duration: two to four injections per 12-month period. For chronic radiculopathy or post herpetic neuralgia or intercostal neuralgia, injections may be repeated only when a functional documented response produces a positive result. A positive result could include positive pain response, a return to baseline function as established at MMI, return to increased work duties, and measurable improvement in physical activity goals including return to baseline after an exacerbation. Injections may only be repeated when these functional and time goals are met and verified by the designated primary physician.

c. Time frames for zygapophyseal (Facet) injections:

i. maintenance duration: four injections per year and limited to three joint levels either unilaterally or bilaterally as in facet joint and medial branch facet joint. injections may be repeated (instead of proceeding with RF) only when a functional documented response lasts for three months. A positive result would include a return to baseline function as established at MMI, return to increased work duties, and a measurable improvement in physical activity goals including return to baseline after an exacerbation. Injections may only be repeated when these functional and time goals are met and verified by the designated primary physician.

d. Time frames for radiofrequency medial branch neurotomy/facet rhizotomy and sacroiliac joint (lateral branch neurotomy and other peripheral nerves listed in these rules:

i. maintenance duration: two times per year not exceeding three levels. The patient must meet the criteria as described in radio frequency denervation. The initial indications including repeat blocks and limitations apply. The long-term effects of repeat rhizotomies, especially on younger patients are unknown. In addition, the patient should always reconsider all of the possible permanent complications before consenting to a repeat procedure. There are no studies addressing the total number of RF neurotomies that should be done for a patient. Patient should receive at least six months with improvement of 50 percent or more in order to qualify for repeat procedures;

ii. optimum/maximum maintenance duration: twice a year after the initial rhizotomy.

9. Purchase or Rental of Durable Medical Equipment (DME). It is recognized that some patients may require ongoing use of self-directed modalities for the purpose of

maintaining function and/or analgesic effect. Purchase or rental of modality based equipment should be done only if the assessment by the physician and/or physical/occupational therapist has determined the effectiveness, compliance, and improved or maintained function by its application. It is generally felt that large expense purchases such as spas, whirlpools, and special mattresses are not necessary to maintain function.

10. Implanted programmable pumps or implanted spinal cord stimulators. facet pain, sacroiliac joint pain, genicular nerve pain, peripheral nerve pain and occasional acute exacerbation of radicular pain is common in patients with these implanted devices. It is necessary to continue to treat previously treated genicular nerve pain, facet pain, sacroiliac joint pain, peripheral nerve pain and occasional radicular pain with injections, and maintenance RF ablation and occasional Epidural injections as listed elsewhere in these rules. The presence of these implanted devices does not preclude diagnosis and treatment of these conditions as well as maintenance of these conditions both before and after implantation of these devices. Also these implanted devices require regular maintenance, adjustments; pump refills every one to six months, stimulator adjustments and management for the life of these devices.

**AUTHORITY NOTE:** Promulgated in accordance with R.S. 23:1203.1.

**HISTORICAL NOTE:** Promulgated by the Louisiana Workforce Commission, Office of Workers Compensation Administration, LR 37:1713 (June 2011), amended LR 46:250 (February 2020), repromulgated LR 46:399 (March 2020).

## Subchapter B. Complex Regional Pain Syndrome

Editor's Note: Form LWC-WC 1009. Disputed Claim for Medical Treatment has been moved to §2328 of this Part.

### §2117. Introduction

A. This document has been prepared by the Louisiana Workforce Commission, Office of Workers' Compensation (OWCA) and should be interpreted within the context of guidelines for physicians/providers treating individuals qualifying under Louisiana's Workers' Compensation Act as injured workers with cervical spine injuries. Although the primary purpose of this document is advisory and educational, these guidelines are enforceable under the Louisiana Workers Compensation Act. All medical care, services, and treatment owed by the employer to the employee in accordance with the Louisiana Workers' Compensation Act shall mean care, services, and treatment in accordance with these guidelines. Medical Care, services, and treatment that varies from these guidelines shall also be due by the employer when it is demonstrated to the medical director of the office by a preponderance of the scientific medical evidence, that a variance from these guidelines is reasonably required to cure or relieve the injured worker from the effects of the injury or occupational disease given the circumstances. Therefore, these guidelines are not relevant as evidence of a provider's legal standard of professional care. To properly utilize this document, the reader should not skip nor overlook any sections.

**AUTHORITY NOTE:** Promulgated in accordance with R.S. 23:1203.1.

**HISTORICAL NOTE:** Promulgated by the Louisiana Workforce Commission, Office of Workers Compensation Administration, LR 37:1716 (June 2011), amended LR 46:252 (February 2020).

### §2119. General Guideline Principles

A. The principles summarized in this Section are key to the intended implementation of all Office of Workers' Compensation medical treatment guidelines and critical to the reader's application of the guidelines in this document.

1. Application of Guidelines. The OWCA provides procedures to implement medical treatment guidelines and to foster communication to resolve disputes among the provider, payer, and patient through the Worker's Compensation Act.

2. Education. Education of the patient and family, as well as the employer, insurer, policy makers and the community should be the primary emphasis in the treatment of workers' compensation injuries. Currently, practitioners often think of education last, after medications, manual therapy, and surgery. Practitioners must implement strategies to educate patients, employers, insurance systems, policy makers, and the community as a whole. An education-based paradigm should always start with inexpensive communication providing reassuring and evidence-based information to the patient. More in-depth education is currently a component of treatment regimens which employ functional, restorative, preventive and rehabilitative programs. No treatment plan is complete without addressing issues of individual and/or group patient education as a means of facilitating self-management of symptoms and prevention. Facilitation through language interpretation, when necessary, is a priority and part of the medical care treatment protocol.

3. Treatment parameter duration time frames for specific interventions commence once treatments have been initiated, not on the date of injury. Obviously, duration will be impacted by patient adherence, as well as availability of services. Clinical judgment may substantiate the need to accelerate or decelerate the time frames discussed in this document. Such deviation shall be in accordance with R.S. 23:1203.1.

4. Active interventions emphasizing patient responsibility, such as therapeutic exercise and/or functional treatment, are generally emphasized over passive modalities, especially as treatment progresses. Generally, passive interventions are viewed as a means to facilitate progress in an active rehabilitation program with concomitant attainment of objective functional gains.

5. Active Therapeutic Exercise Program. Exercise program goals should incorporate patient strength, endurance, flexibility, coordination, and education. This includes functional application in vocational or community settings.

6. Positive Patient Response. Positive results are defined primarily as functional gains that can be objectively measured.

a. Objective functional gains include, but are not limited to, positional tolerances, range-of-motion (ROM), strength, and endurance, activities of daily living, ability to function at work, cognition, psychological behavior, and efficiency/velocity measures that can be quantified. Subjective reports of pain and function should be considered and given relative weight when the pain has anatomic and physiologic correlation. Anatomic correlation must be based on objective findings.

7. Re-Evaluation of Treatment Every Three to Four Weeks. If a given treatment or modality is not producing positive results within three to four weeks, or within the time to produce effect in the non-chronic pain guidelines, the patient should be re-evaluated by the treating physician that referred him to PT and consideration should be given for a referral to a pain specialist or surgeon or other appropriate specialist for other treatment options. Reconsideration of diagnosis should also occur in the event of poor response to a seemingly rational intervention.

8. Surgical Interventions. Surgery should be contemplated within the context of expected functional outcome and not purely for the purpose of pain relief. The concept of "cure" with respect to surgical treatment by itself is generally a misnomer. All operative interventions must be based upon positive correlation of clinical findings, clinical course, and diagnostic tests. A comprehensive assimilation of these factors must lead to a specific diagnosis with positive identification of pathologic conditions.

9. Pharmacy-Louisiana Law and Regulation. All prescribing will be done in accordance with the laws of the state of Louisiana as they pertain respectively to each individual licensee, including, but not limited to: Louisiana State Board of Medical Examiners regulations governing medications used in the treatment of non-cancer-related chronic or intractable pain; Louisiana Board of Pharmacy Prescription Monitoring Program; Louisiana Department of Health and Hospitals licensing and certification standards for pain management clinics; other laws and regulations affecting the prescribing and dispensing of medications in the state of Louisiana.

10. Six Month-Time Frame. Injuries resulting in temporary total disability require maintenance treatment and may not attain return to work in six months.

11. Return To Work. Return to work is therapeutic, assuming the work is not likely to aggravate the basic problem or increase long-term pain. An injured worker's return-to-work status shall not be the sole cause to deny reasonable and medically necessary treatment under these guidelines. Two good practices are: early contact with injured workers and provide modified work positions for short-term injuries. The practitioner may provide specific physical limitations and the patient should never be released to non-specific and vague descriptions such as "sedentary" or "light duty." The following physical limitations should be

considered and modified as recommended: lifting, pushing, pulling, crouching, walking, using stairs, bending at the waist, awkward and/or sustained postures, tolerance for sitting or standing, hot and cold environments, data entry and other repetitive motion tasks, sustained grip, tool usage and vibration factors. Even if there is residual chronic pain, return-to-work is not necessarily contraindicated. The practitioner should understand all of the physical demands of the patient's job position before returning the patient to full duty and should request clarification of the patient's job duties. Clarification should be obtained from the employer or, if necessary, from including, but not limited to, occupational health nurse, physical therapist, occupational therapist, vocational rehabilitation specialist, or an industrial hygienist, chiropractor or another professional. American Medical Association clarifies "disability" as "activity limitations and/or participation restrictions in an individual with a health condition, disorder or disease" versus "impairment" as "a significant deviation, loss, or loss of use of any body structure or body function in an individual with a health condition, disorder or disease".

12. Delayed Recovery. Within the discretion of the treating physician, strongly consider a psychological evaluation, if not previously provided, as well as initiating interdisciplinary rehabilitation treatment and vocational goal setting, for those patients who are failing to make expected progress 6 to 12 weeks after initiation of treatment of an injury. The OWCA recognizes that 3 to 10 percent of all industrially injured patients will not recover within the timelines outlined in this document despite optimal care. Such individuals may require treatments beyond the limits discussed within this document, but such treatment requires clear documentation by the authorized treating practitioner focusing on objective functional gains afforded by further treatment and impact upon prognosis.

13. Recommendations and Inclusion of Medical Evidence. All recommendations are based on available evidence and/or consensus judgment. It is generally recognized that early reports of a positive treatment effect are frequently weakened or overturned by subsequent research. When interpreting medical evidence statements in the guideline, the following apply to the strength of recommendation.

Strong	Level 1 Evidence	We Recommend
Moderate	Level 2 and Level 3 Evidence	We Suggest
Weak	Level 4 Evidence	Treatment is an Option
Inconclusive	Evidence is Either Insufficient or Conflicting	

a. Consensus guidelines are generated by a professional organization that the guidelines are intended to serve. A committee of specialists and experts are selected by the organization to create an unbiased, vetted recommendation for the treatment of specific issues within the realm of their expertise. All recommendations in the guideline are considered to represent reasonable care in appropriately selected cases, regardless of the level of evidence or consensus statement attached to it. Those procedures considered inappropriate, unreasonable, or

unnecessary are designated in the guideline as “not recommended.”

14. Treatment of Pre-Existing Conditions The conditions that preexisted the work injury/disease will need to be managed under two circumstances: (a) A pre-existing condition exacerbated by a work injury/disease should be treated until the patient has returned to their objectively verified prior level of functioning or Maximum Medical Improvement (MMI); and (b) A pre-existing condition not directly caused by a work injury/disease but which may prevent recovery from that injury should be treated until its objectively verified negative impact has been controlled. The focus of treatment should remain on the work injury/disease.

B. The remainder of this document should be interpreted within the parameters of these guideline principles that may lead to more optimal medical and functional outcomes for injured workers.

AUTHORITY NOTE: Promulgated in accordance with R.S. 23:1203.1.

HISTORICAL NOTE: Promulgated by the Louisiana Workforce Commission, Office of Workers Compensation Administration, LR 37:1716 (June 2011), amended by the Louisiana Workforce Commission, Office of Workers Compensation, LR 40:1157 (June 2014), amended LR 46:253 (February 2020).

### **§2121. Introduction to Complex Regional Pain Syndrome**

A. Complex regional pain syndrome (CRPS types I and II) describes painful syndromes, which were formerly referred to as reflex sympathetic dystrophy (RSD) and causalgia. CRPS conditions usually follow injury that appears regionally and have a distal predominance of abnormal findings, exceeding the expected clinical course of the inciting event in both magnitude and duration and often resulting in significant impairment of limb function.

B. CRPS-I (RSD) is a syndrome that usually develops after an initiating noxious event, is not limited to the distribution of a single peripheral nerve, and is apparently disproportionate to the inciting event. It is associated at some point with evidence of edema, changes in skin, blood flow, abnormal sudomotor activity in the region of the pain, allodynia or hyperalgesia. The site is usually in the distal aspect of an affected extremity or with a distal to proximal gradient. The peripheral nervous system and possibly the central nervous system are involved.

C. CRPS-II (causalgia) is the presence of burning pain, allodynia, and hyperpathia usually in the hand or foot after partial injury to a nerve or one of its major branches. Pain is within the distribution of the damaged nerve but not generally confined to a single nerve.

D. Stages seen in CRPS-I are not absolute and in fact, may not all be observed in any single patient. In some patients, stages may be missed or the patient may remain for long periods of time in one stage.

E. Stage 1—Acute (Hyperemic)

1. Starts at the time of injury or even weeks later. Associated with spontaneous pain, aching, burning. Typically restricted to the distal extremity. Hyperpathia, allodynia, hypoesthesia or hyperesthesia may be present. Initially, hair and nail growth may be increased but later decrease. Skin may be warm or cold.

F. Stage 2—Dystrophic (Ischemic)

1. Spontaneous burning and/or aching pain, more pronounced hyperpathia and/or allodynia. Signs of chronic sympathetic over activity include reduced blood flow; sudomotor changes; increased edema; cyanotic skin; muscle wasting; decreased hair and nail growth; and osteoporosis.

G. Stage 3—Atrophic

1. Signs and symptoms of this stage include pain may be less prominent; decreased hyperpathia and/or allodynia; reduction in blood flow; skin temperature and sweating may be increased or decreased; irreversible trophic changes in skin and integument; and pronounced muscle atrophy with contractures.

AUTHORITY NOTE: Promulgated in accordance with R.S. 23:1203.1.

HISTORICAL NOTE: Promulgated by the Louisiana Workforce Commission, Office of Workers Compensation Administration, LR 37:1717 (June 2011).

### **§2123. Definitions**

A. *After Sensation*—refers to the abnormal persistence of a sensory perception, provoked by a stimulus even though the stimulus has ceased.

B. *Allodynia*—pain due to a non-noxious stimulus that does not normally provoke pain.

1. *Mechanical Allodynia*—refers to the abnormal perception of pain from usually non-painful mechanical stimulation.

2. *Static Mechanical Allodynia*—refers to pain obtained by applying a single stimulus such as light pressure to a defined area.

3. *Dynamic Mechanical Allodynia*—obtained by moving the stimulus such as a brush or cotton tip across the abnormal hypersensitive area.

4. *Thermal Allodynia*—refers to the abnormal sensation of pain from usually non-painful thermal stimulation such as cold or warmth.

C. *Central Pain*—pain initiated or caused by a primary lesion or dysfunction in the central nervous system (CNS).

D. *Central Sensitization*—the experience of pain evoked by the excitation of non-nociceptive neurons or of nerve fibers that normally relay non-painful sensations to the spinal cord. This result when non-nociceptive afferent neurons act on a sensitized CNS.

E. *Dystonia*—state of abnormal (hypo or hyper) tonicity in any of the tissues.

F. *Hyperalgesia*—refers to an exaggerated pain response from a usually painful stimulation.

G. *Hyperemia*—presence of increased blood in a part or organ.

H. *Hyperesthesia* (Positive Sensory Phenomenon)—includes allodynia, hyperalgesia, and hyperpathia. Elicited by light touch, pin-prick, cold, warm vibration, joint position sensation or two-point discrimination, which is perceived as increased or more.

I. *Hyperpathia*—refers to an abnormally painful and exaggerated reaction to stimulus, especially to a repetitive stimulus, in a patient who perceives the stimulus as less intense because of an increased threshold.

J. *Hypoesthesia* (also *hypesthesia*)—diminished sensitivity to stimulation.

K. *Pain Behavior*—the nonverbal actions (such as grimacing, groaning, limping, using visible pain relieving or support devices and requisition of pain medications, among others) that are outward manifestations of pain, and through which a person may communicate that pain is being experienced.

L. *Sudomotor Changes*—alteration in function of sweat glands; sweat output may increase or decrease due to changes in autonomic input to the gland.

M. *Sympathetically Maintained Pain* (SMP)—a pain that is maintained by sympathetic efferent innervations or by circulating catecholamines.

N. *Trophic Changes*—tissue alterations due to interruption of nerve or blood supply; may include changes in hair growth and texture of skin.

O. *Vasomotor Changes*—alteration in regulation of dilation or constriction of blood vessels.

AUTHORITY NOTE: Promulgated in accordance with R.S. 23:1203.1.

HISTORICAL NOTE: Promulgated by the Louisiana Workforce Commission, Office of Workers Compensation Administration, LR 37:1718 (June 2011).

## §2125. Initial Evaluation

A. All potential pain generators should be thoroughly investigated by complete neurological and musculoskeletal exam and diagnostic procedures. Because CRPS-I is commonly associated with other injuries, it is essential that all related diagnoses are defined and treated. These disturbances are typically restricted to one extremity, usually distally, but are variable in their expression.

1. History and physical examination (Hx& PE) The history and physical exam establish the basis for subsequent diagnostic and therapeutic procedures. When clinical evaluation findings do not complement the findings of other diagnostic procedures, clinical findings should have preference. Before the diagnosis of CRPS-I or CRPS-II is established, an experienced practitioner must perform a detailed neurological and musculoskeletal exam to exclude

other potentially treatable pain generators or neurological lesions.

a. Medical History. As in other fields of medicine, a thorough patient history is an important part of the evaluation of pain. In taking such a history, factors influencing a patients' current status can be made clear and taken into account when planning diagnostic evaluation and treatment. History should ascertain the following elements:

- i. Causality: How did this injury occur? Was the problem initiated by a work-related injury or exposure?
- ii. Presenting symptoms:
  - (a). severe, generally unremitting burning and/or aching pain, and/or allodynia;
  - (b). swelling of the involved area;
  - (c). changes in skin color;
  - (d). asymmetry in nail and/or hair growth;
  - (e). abnormal sweat patterns of the involved extremity;
  - (f). dystonia; and/or
  - (g). subjective temperature changes of the affected area.

b. Pain History. The patient's description of and response to pain is one of the key elements in treatment. Characterization of the patient's pain and of the patient's response to pain is one of the key elements in treatment.

- i. Site of Pain. Localization and distribution of the pain help determine the type of pain the patient has (i.e., central versus peripheral).
- ii. Pain Drawing/Visual Analog Scale (VAS)
- iii. Duration
- iv. Place of onset
- v. Pain Characteristics. Time of pain occurrence as well as intensity, quality and radiation give clues to the diagnosis and potential treatment.
- vi. Response of Pain to Activity
- vii. Associated Symptoms. Does the patient have numbness or paresthesia, dysesthesia, weakness, bowel or bladder dysfunction, decreased temperature, increased sweating, cyanosis or edema? Is there local tenderness, allodynia, hyperesthesia or hyperalgesia?
- c. Substance Use/Abuse:
  - i. alcohol use;
  - ii. smoking history;
  - iii. History of drug use and abuse.
  - iv. Caffeine or caffeine-containing beverages.
- d. Other Factors Affecting Treatment Outcome:
  - i. Compensation/disability/litigation;

ii. Treatment Expectations. What does the patient expect from treatment: complete relief of pain or reduction to a more tolerable level?

e. Medical Management History. Refer to the Chronic Pain Disorder Medical Treatment Guideline's for detailed elements when performing a review of prior medical management. In addition, history may include:

i. Chronological review of medical records including previous medical evaluations and response to treatment interventions.

ii. History of diagnostic tests and results including but not limited to any response to sympathetic nerve blocks, results of general laboratory studies, EMG and nerve conduction studies, radiological examinations, including triple phase bone scan or thermography with autonomic stress testing.

iii. Medications, including prescription, over-the-counter and herbal/dietary supplements.

iv. Review of Systems check list. Determine if there is any interplay between the pain complaint and other medical conditions.

v. Psychosocial Functioning. Determine if the following are present: current symptoms of depression or anxiety, evidence of stressors in the workplace or at home, and past history of psychological problems. It is recommended that patients diagnosed with CRPS be referred for a psychosocial evaluation. All patients with CRPS have Chronic Pain, and are likely to suffer psychosocial consequences.

vi. Pre-existing Conditions. Treatment of these conditions is appropriate when the preexisting condition is aggravated by work related injury.

f. Physical Examination. Should include examination techniques applicable to those portions of the body in which the patient is experiencing subjective symptomatology and should include:

i. Inspection. Changes in appearance of the involved area, to include trophic changes, changes in hair and nail growth, muscular atrophy, changes in skin turgor, swelling and color changes.

ii. Temperature Evaluation. Palpable temperature changes may not be detectable in early disease stages, and the examiner will generally only be able to appreciate significant temperature variations. Thermography, or other objective testing may be necessary to display temperature asymmetries.

iii. Motor Evaluation. Involuntary movements, dystonia or muscle weakness in the involved limb(s).

iv. Sensory Evaluation. A detailed sensory examination is crucial in evaluating a patient with chronic pain complaints. Presence of allodynia. Anatomic pattern of any associated sensory abnormalities to light touch, deep touch, pain and thermal stimulation. Quantitative sensory testing may be useful.

v. Musculoskeletal Evaluation. Presence of associated myofascial problems, such as contractures, ROM or trigger points.

vi. Evaluation of Nonphysiologic Findings. Determine the presence of the following: Variabilities on formal exam including variable sensory exam, inconsistent tenderness, and or swelling secondary to extrinsic sources; Inconsistencies between formal exam and observed abilities of range of motion, motor strength, gait and cognitive/emotional state; and/or, observation of consistencies between pain behavior, affect and verbal pain rating, and affect and physical re-examination.

AUTHORITY NOTE: Promulgated in accordance with R.S. 23:1203.1.

HISTORICAL NOTE: Promulgated by the Louisiana Workforce Commission, Office of Workers Compensation Administration, LR 37:1718 (June 2011), amended LR 46:254 (February 2020).

### §2127. Diagnostic Procedures

A. Diagnostic imaging is a generally accepted, well-established, and widely used diagnostic procedure when specific indications, based on history and physical examination, are present. Physicians should refer to individual OWCA guidelines for specific information about specific testing procedures.

#### 1. Plain Film Radiography:

a. Description. A radiological finding in CRPS may be unilateral osteoporosis; however, osteoporosis may be absent in many cases. In CRPS-I, the osteoporosis may be rapid in progression. The disorder typically affects the distal part of an extremity such as a hand or foot, yet intermediate joints such as the knee or elbow may be involved.

b. Results. The radiological appearance of osteoporosis has been characterized as spotty or patchy. Although CRPS-I may exist in the absence of osteoporosis, the diagnosis of CRPS-I cannot be made solely on the basis of radiographic appearance or the osteoporosis alone.

#### 2. Triple Phase Bone Scan:

a. Description. Radionuclide imaging scintigraphy employing radio-pharmaceutical technetium coupled to a phosphate complex has been used to help facilitate the diagnosis of CRPS-I. It was hoped that a three-phase radionuclide study would be selective in the face of demineralization of the bone as seen in CRPS-I. However there are many different types of conditions that can produce osteoporosis and a triple-phase bone scan does not distinguish between the causes of bone demineralization.

b. Results. Clinical information can be derived from each of the three phases of the bone scan following injection. In the early course of CRPS-I, there is an increased uptake seen during Phase 1. However, in the late course of the disease process, there can actually be a decreased uptake seen. In Phase 2, which reflects the soft tissue vascularity, an increased diffuse uptake may be appreciated during the early course of CRPS-I. During Phase 3, one will see a diffuse uptake of multiple bone involvement of the involved limb,

reflecting the bone turnover secondary to osteoporosis. Negative bone scans may be found in up to 40 percent of patients clinically diagnosed with CRPS-I; however when positive it may help to confirm the diagnosis of CRPS-I.

#### B. Injections—diagnostic sympathetic

1. Description. Diagnostic sympathetic injections are generally accepted procedures to aid in the diagnosis of CRPS I and II and SMP. Sympathetic blocks lack specificity for CRPS I and II. Each diagnostic injection has inherent risk and risk versus benefit should always be evaluated when considering injection therapy. Since these procedures are invasive, less invasive or non-invasive procedures should be considered first. Selection of patients, choice of procedure, and localization of the level for injection should be determined by clinical information.

2. Special Considerations. Injections with local anesthetics of differing duration are required to confirm a diagnosis. In some cases, injections at multiple levels may be required to accurately diagnose pain. Refer to “Injections – Therapeutic” for information on specific injections.

a. Since fluoroscopic and/or CT guidance during procedures is recommended to document technique and needle placement, an experienced physician should perform the procedure. The practitioner should have experience in ongoing injection training workshops provided by organizations such as the American Society of Interventional Pain Physicians (ASIPP) or Spine Intervention Society (SIS) and be knowledgeable in radiation safety. In addition, practitioners should obtain fluoroscopy training and radiation safety credentialing from their Departments of Radiology, as applicable.

3. Complications. Complications may include transient neurapraxia, nerve injury, inadvertent spinal injection, infection, venous or arterial vertebral puncture, laryngeal paralysis, respiratory arrest, vasovagal effects, as well as permanent neurological damage.

4. Contraindications. Absolute contraindications of diagnostic injections include: bacterial infection – systemic or localized to region of injection, bleeding diatheses, hematological conditions, and possible pregnancy. Relative contraindications of diagnostic injections may include: aspirin/antiplatelet therapy (drug may be held for at least three days prior to injection).

5. Test Results. The interpretation of the test result is primarily based upon pain relief of 50 percent or greater. The diagnostic significance of the test result should be evaluated in conjunction with clinical information and further information can be obtained from functional reassessment performed by physical and/or occupational therapy or from results of other diagnostic procedures following a successful block.

a. Local anesthetics of different durations of action should be considered and could take the place of doing a "placebo" block (i.e. - procaine, lidocaine, marcaine). Pain relief should be at least 50 percent or greater for the duration of the local anesthetic. It should be noted that with CRPS-I it

is not unusual for the relief to last longer than the duration of the local anesthetic. If a placebo block is done, the needle should not be placed down to the sympathetic chain nor should an injection of saline be done around the sympathetic chain. Contact with the sympathetic nerves by a needle or pressure on the chain by saline can cause a temporary sympathetic block and give a false positive placebo test. A "sham block" would be preferable to see if the patient is a placebo responder. Additionally, patients with definite CRPS-I can also be placebo responders. The fact that the patient responds positively to a placebo does not mean that he/she does not have CRPS-1. It merely means that the patient is a placebo responder. This increases the value of doing another confirmatory test.

i. Stellate Ganglion Block. For diagnosis and treatment of sympathetic pain involving the face, head, neck, and upper extremities secondary to CRPS-I and II. This block is commonly used for differential diagnosis and is the preferred treatment of CRPS-I pain involving the upper extremity. Kuntz Fiber Blockade (T1-T3 sympathetic chain) on the affected side is necessary for upper extremity pain not responsive to stellate ganglion blockade.

(a). For diagnostic testing, use three blocks over a 3-14 day period. For a positive response, pain relief should be 50 percent or greater for the duration of the local anesthetic and pain relief should be associated with functional improvement.

ii. Lumbar Sympathetic Block. Useful for diagnosis and treatment of pain of the pelvis and lower extremity secondary to CRPS-I and II. This block is commonly used for differential diagnosis and is the preferred treatment of sympathetic pain involving the lower extremity. For diagnostic testing, use three blocks over a 3-14 day period. For a positive response, pain relief should be 50 percent or greater for the duration of the local anesthetic and pain relief should be associated with functional improvement.

iii. Phentolamine Infusion Test. An intravenous infusion of phentolamine, an alpha 2 blocker, which results in generalized systemic sympatholysis. The infusion begins with intravenous saline for placebo control. For a positive response, pain relief should be 50 percent or greater and associated with functional improvement. This test aids in the diagnosis of Sympathetically Maintained Pain.

iv. Thoracic Sympathetic Block. Useful for abdominal or pelvic visceral pain secondary to CRPS I and II. Use the same guidance as for lumbar sympathetic Block.

#### C. Thermography (infrared stress thermography)

1. Description. A generally accepted procedure with some evidence to support its limited use. Infrared thermography may be useful for patients with suspected CRPS-I and II, and SMP. Thermography can distinguish abnormal thermal asymmetry of 1.0 degree Celsius which is not distinguishable upon physical examination. It may also be useful in cases of suspected small caliber fiber

neuropathy and to evaluate patient response to sympatholytic interventions.

2. Special Considerations. The practitioner who supervises and interprets the thermographic evaluation shall follow recognized protocols and be board certified by one of the examining boards of the American Academy of Medical Infrared Imaging, American Academy of Thermology, or American Chiropractic College of Thermology.

3. Medications with anticholinergic activity (tricyclics, cyclobenzaprine, antiemetics, antipsychotics) may interfere with autonomic testing. The pre-testing protocol which includes cessation of specific medications therapy must be followed for accurate test results. Results of autonomic testing may be affected by peripheral polyneuropathy, radiculopathy or peripheral nerve injury, peripheral vascular disease, generalized autonomic failure, or by Shy-Drager syndrome.

4. Thermographic Tests. Functional autonomic stress testing may include any of the following methods:

a. Cold Water Stress Test (Cold Pressor Test). Paroxysmal cooling is strongly suggestive of vasomotor instability.

b. Warm Water Stress Test. Paroxysmal warming is strongly suggestive of vasomotor instability.

c. Digital infrared temperature monitoring should be used before and after sympathetic block where indicated to evaluate response to sympatholytic intervention.

#### D. Autonomic test battery

1. Description. Resting skin temperature (RST), resting sweat output (RSO), and quantitative sudomotor axon reflex test (QSART) are a recently developed test battery with some evidence to support its limited use in the diagnosis of CRPS-I. Prior authorization is required.

2. Special Considerations. Medications with anticholinergic activity (tricyclics, cyclobenzaprine, antiemetics, antipsychotics) may interfere with autonomic testing. Results of autonomic testing may be affected by peripheral polyneuropathy, radiculopathy or peripheral nerve injury, peripheral vascular disease, generalized autonomic failure, or by Shy-Drager syndrome.

3. Test Battery. These tests measure asymmetries in physiologic manifestations of autonomic activity between an affected limb and an unaffected contralateral limb. Skin temperature reflects vasomotor activity and sweat output measures sudomotor activity. The results of the three test components must be combined and scored. The battery of tests must include a measurement of each component (RST, RSO, and QSART).

a. Infrared Resting Skin Temperature (RST) provides thermographic measurements between the affected and unaffected limb. Generally, a 1° Celsius difference is significant.

b. Resting Sweat Output (RSO) measures an increase or reduction of 50 percent between the affected and unaffected limb.

c. Quantitative Sudomotor Axon Reflex Test (QSART) measures the sweat output elicited by iontophoretic application of acetylcholine. An increase or reduction of 50 percent between the affected and unaffected limb is significant.

E. Other Diagnostic Tests Not Specific for CRPS. The following tests and procedures are not used to establish the diagnosis of CRPS but may provide additional information. The following are listed in alphabetical order.

1. Electrodiagnostic Procedures. Electromyography (EMG) and Nerve Conduction Studies (NCS) are generally accepted, well-established and widely used for localizing the source of the neurological symptoms and establishing the diagnosis of focal nerve entrapments, such as carpal tunnel syndrome or radiculopathy, which may contribute to or coexist with CRPS II (causalgia). Traditional electrodiagnosis includes nerve conduction studies, late responses, (F-Wave, H-reflex) and electromyographic assessment of muscles with needle electrode examination. As CRPS II occurs after partial injury to a nerve, the diagnosis of the initial nerve injury can be made by electrodiagnostic studies. The later development of sympathetically mediated symptomatology however, has no pathognomonic pattern of abnormality on EMG/NCS. When issues of diagnosis are in doubt, a referral or consultation with a physiatrist or neurologist trained in electrodiagnosis is appropriate.

2. Laboratory Tests are generally accepted well-established and widely used procedures and can provide useful diagnostic and monitoring information. They may be used when there is suspicion of systemic illness, infection, neoplasia, or underlying rheumatologic disorder, connective tissue disorder, or based on history and/or physical examination. Tests include, but are not limited to:

a. Complete Blood Count (CBC) with differential can detect infection, blood dyscrasias, and medication side effects.

b. Erythrocyte sedimentation rate, rheumatoid factor, antinuclear antigen (ANA), human leukocyte antigen (HLA), and C-reactive protein can be used to detect evidence of a rheumatologic, infection, or connective tissue disorder, serum protein electrophoresis.

c. Thyroid, glucose and other tests to detect endocrine disorders.

d. Serum calcium, phosphorous, uric acid, alkaline phosphatase, and acid phosphatase can detect metabolic bone disease.

e. urinalysis for calcium, phosphorus, hydroxyproline, or hematuria;

f. Liver and kidney function may be performed for baseline testing and monitoring of medications; and



g. Toxicology Screen and/or Blood Alcohol Level if suspected drug or alcohol abuse.

3. Peripheral Blood Flow (Laser Doppler or Xenon Clearance Techniques): This is currently being evaluated as a diagnostic procedure in CRPS-I and is not recommended by the OWCA at this time.

a. Personality / Psychosocial / Psychiatric / Psychological Evaluation:

i. These are generally accepted and well-established diagnostic procedures with selective use in the upper extremity population, but have more widespread use in subacute and chronic upper extremity populations. Diagnostic testing procedures may be useful for patients with symptoms of depression, delayed recovery, chronic pain, recurrent painful conditions, disability problems, and for preoperative evaluation. Psychological/psychosocial and measures have been shown to have predictive value for postoperative response, and therefore should be strongly considered for use pre-operatively when the surgeon has concerns about the relationship between symptoms and findings, or when the surgeon is aware of indications of psychological complication or risk factors for psychological complication (e.g. childhood psychological trauma). Psychological testing should provide differentiation between pre-existing conditions versus injury caused psychological conditions, including depression and posttraumatic stress disorder. Psychological testing should incorporate measures that have been shown, empirically, to identify comorbidities or risk factors that are linked to poor outcome or delayed recovery.

ii Formal psychological or psychosocial evaluation should be performed on patients not making expected progress within 6 to 12 weeks following injury and whose subjective symptoms do not correlate with objective signs and test results. In addition to the customary initial exam, the evaluation of the injured worker should specifically address the following areas:

- (a). employment history;
- (b). interpersonal relationships-both social and work;
- (c). patient activities;
- (d). current perception of the medical system;
- (e). current perception/attitudes toward employer/job
- (f). results of current treatment
- (g). Risk factors and psychological comorbidities that may influence outcome and that may require treatment.
- (h). Childhood history, including history of childhood psychological trauma, abuse and family history of disability.

iii. Personality/psychological/psychosocial evaluations consist of two components, clinical interview and psychological testing. Results should help clinicians

with a better understanding of the patient in a number of ways. Thus the evaluation result will determine the need for further psychosocial interventions; and in those cases, Diagnostic and Statistical Manual of Mental Disorders (DSM) diagnosis should be determined and documented. The evaluation should also include examination of both psychological comorbidities and psychological risk factors that are empirically associated with poor outcome and/or delayed recovery. An individual with a Ph.D., Psy.D, or psychiatric M.D./D.O. credentials should perform initial evaluations, which are generally completed within one to two hours. A professional fluent in the primary language of the patient is preferred. When such a provider is not available, services of a professional language interpreter should be provided.

iv. Frequency. One-time visit for the clinical interview. If psychometric testing is indicated as a part of the initial evaluation, time for such testing should not exceed an additional two hours of professional time.

(a). Tests of Psychological Functioning

(i). Psychometric testing is a valuable component of a consultation to assist the physician in making a more effective treatment plan. Psychometric testing is useful in the assessment of mental conditions, pain conditions, cognitive functioning, treatment planning, vocational planning and evaluation of treatment effectiveness. There is no general agreement as to which standardized psychometric tests should be specifically recommended for psychological evaluations of chronic pain conditions. It is appropriate for the mental health provider to use their discretion and administer selective psychometric tests within their expertise and within standards of care in the community. Some of these tests are available in Spanish and other languages, and many are written at a 6th grade reading level.

4. Special Tests. Tests are generally well-accepted tests and are performed as part of a skilled assessment of the patients' capacity to return to work, strength capacity, and or physical work demands classifications and tolerance. Tests include Computer-Enhanced Evaluations, Functional Capacity Evaluation (FCE), Jobsite Evaluation, Vocational Assessment, and Work Tolerance Screening. Refer to the Chronic Pain Medical Treatment Guidelines for detailed information and frequency of each special testing procedure.

AUTHORITY NOTE: Promulgated in accordance with R.S. 23:1203.1.

HISTORICAL NOTE: Promulgated by the Louisiana Workforce Commission, Office of Workers Compensation Administration, LR 37:1719 (June 2011), amended LR 46:254 (February 2020).

**§2129. Diagnosis of CRPS**

A. Diagnostic Components of CRPS-I (RSD)

1. Subjective Complaints. Complaint of pain, usually burning or aching pain and out of proportion to identified pathology. May be sharp, or lancinating. Frequently is present without provocation or movement.

2. Physical Findings:

a. Swelling, generally unilateral and variable in presentation.

b. Vasomotor signs – Unilateral. Initial extremity warming early on, coldness of extremity as condition progresses. Discoloration of skin usually darker blue or purple, may be mottled, may be paler.

c. Sudomotor sign – Increased sweating of the involved extremity.

d. Trophic Changes – Coarse, thick hair, later may be sparse; nails brittle, ridged, may grow faster initially, later grow more slowly; skin is smooth, shiny; digits tapered (pencil pointing); joints stiff with decreased ROM; muscle wasting; motor disturbances; increased physiological tremor, dystonia.

3. Diagnostic Testing Procedures:

- a. x-rays of both extremities;
- b. triple phase bone scan;
- c. sympathetic blocks;
- d. infrared thermogram;
- e. autonomic test battery.

B. Diagnostic Criteria for CRPS

1. CRPS-I (RSD):

a. Patient complains of pain, usually diffuse burning or aching;

b. Patient has physical findings on examination of at least vasomotor and/or sudomotor signs. Allodynia and/or trophic changes add strength to the diagnosis of CRPS-I; and

c. At least two diagnostic testing procedures are positive. Even the most sensitive tests can have false negatives. The patient can still have CRPS-I, if clinical signs are strongly present. In patients with continued signs and symptoms of CRPS-I, further diagnostic testing may be appropriate.

2. CRPS-II (causalgia):

a. Patient complains of pain;

b. Documentation of peripheral nerve injury with pain initially in the distribution of the injured nerve;

c. Patient has physical findings on examination of at least vasomotor and/or sudomotor signs. Allodynia and/or trophic changes add strength to the diagnosis of CRPS-II; and

d. At least two diagnostic testing procedures are positive. Even the most sensitive tests can have false negatives. The patient can still have CRPS-II, if clinical signs are strongly present. In patients with continued signs and symptoms of CRPS-II, further diagnostic testing may be appropriate.

3. Sympathetically Mediated Pain (SMP):

a. Patient complains of pain;

b. Usually does not have clinically detectable vasomotor or sudomotor signs; and

c. Has pain relief with sympathetic blocks.

4. Not CRPS:

a. Patient complains of pain;

b. May or may not have vasomotor or sudomotor signs;

c. No relief with sympathetic blocks; and

d. No more than one other diagnostic test procedure is positive.

AUTHORITY NOTE: Promulgated in accordance with R.S. 23:1203.1.

HISTORICAL NOTE: Promulgated by the Louisiana Workforce Commission, Office of Workers Compensation Administration, LR 37:1722 (June 2011).

**§2131. Therapeutic Procedures—Non-Operative**

A. Non-operative therapeutic rehabilitation is applied to patients with CRPS or SMP who experience chronic and complex problems of de-conditioning and functional disability. Treatment modalities may be utilized sequentially or concomitantly depending on chronicity and complexity of the problem, and treatment plans should always be based on a diagnosis utilizing appropriate diagnostic procedures.

B. Before initiation of any therapeutic procedure, the authorized treating physician, employer and insurer must consider these important issues in the care of the injured worker:

1. Patients undergoing therapeutic procedure(s) should be released or returned to modified or restricted duty during their rehabilitation at the earliest appropriate time. Refer to Return-to-Work for detailed information.

2. Reassessment of the patient's status in terms of functional improvement should be documented after each treatment. If patients are not responding within the recommended time periods, alternative treatment interventions, further diagnostic studies or consultations should be pursued. Continued treatment should be monitored using objective measures such as:

a. Return to work or maintaining work status.

b. Fewer restrictions at work or performing or limitations in activities of daily living (ADL).

c. Decrease in usage of medications.

d. Measurable functional gains, such as increased range of motion or documented increase in strength.

3. Clinicians should provide and document education to the patient. No treatment plan is complete without addressing issues of individual and/or group patient education as a means of facilitating self-management of symptoms.

4. Psychological or psychosocial screening should be performed on all chronic pain patients.

C. The following procedures are listed in alphabetical order.

1. Acupuncture is an accepted and widely used procedure for the relief of pain and inflammation and there is some scientific evidence to support its use. Credentialed practitioners must perform acupuncture evaluations, with experience in evaluation and treatment of chronic pain patients. The exact mode of action is only partially understood. Western medicine studies suggest that acupuncture stimulates the nervous system at the level of the brain, promotes deep relaxation, and affects the release of neurotransmitters. Acupuncture is commonly used as an alternative or in addition to traditional Western pharmaceuticals. It is commonly used when pain medication is reduced or not tolerated. It may be used as an adjunct to physical rehabilitation, surgical intervention, and or as part of multidisciplinary treatment to hasten the return of functional activity. Acupuncture should be performed by licensed practitioners.

a. Refer to the Chronic Pain Medical Treatment guideline's for detailed information on acupuncture and timeframe parameters.

2. Biofeedback is a generally well-accepted form of behavioral medicine that helps patients learn self-awareness and self-regulation skills for the purpose of gaining greater control of their physiology. Biofeedback treatment is intended to assist patients in managing stress-related psychophysiological reactions that may arise as a reaction to organic pain, or which may cause pain. The biofeedback specialist may utilize a variety of interventions for teaching physiological self-management. Biological feedback may then be provided through mechanisms ranging from simple devices to electronic instrumentation, and displayed or fed back to the patient visually, auditorially, or tactilely. This enables the patient to identify and refine effective interventions.

a. The application of biofeedback to patients with CRPS is not well researched. However, based on CRPS symptomology, temperature or skin conductance feedback modalities may be of particular interest. Refer to the Chronic Pain Medical Treatment Guideline's for detailed information on biofeedback and time parameters.

3. Disturbances of sleep are common in chronic pain. Although primary insomnia may accompany pain as an independent comorbid condition, it more commonly occurs, secondary to the pain condition itself. Exacerbations of pain often are accompanied by exacerbations of insomnia; the reverse can also occur. Sleep laboratory studies have shown disturbances of sleep architecture in pain patients. Loss of deep slow-wave sleep and increase in light sleep occur and sleep efficiency, the proportion of time in bed spent asleep, is decreased. These changes are associated with patient reports of non-restorative sleep.

a. Many chronic pain patients develop behavioral habits that exacerbate and maintain sleep disturbances. Excessive time in bed, irregular sleep routine, napping, low activity and worrying in bed are all maladaptive responses that can arise in the absence of any psychopathology. There is some evidence that behavioral modification, such as patient education and group or individual counseling, can be effective in reversing the effects of insomnia. Behavioral modifications are easily implemented and can include:

- i. Maintaining a regular sleep schedule, retiring and rising at approximately the same time on weekdays and weekends.
- ii. Avoiding daytime napping.
- iii. Avoiding caffeinated beverages after lunchtime
- iv. Making the bedroom quiet and comfortable, eliminating disruptive lights, sounds television sets, and keeping a bedroom temperature of about 65°F.
- v. Avoiding alcohol or nicotine within two hours of bedtime.
- vi. Avoiding large meals within two hours of bedtime.
- vii. Exercising vigorously during the day, but not within two hours of bedtime, since this may raise core temperature and activate the nervous system.
- viii. Associating the bed with sleep and sexual activity only, using other parts of the home for television, reading and talking on the telephone.
- ix. Leaving the bedroom when unable to sleep for more than 20 minutes, retuning to the bedroom when ready to sleep again.

b. These modifications should be undertaken before sleeping medication is prescribed.

4. Injections — therapeutic. When considering the use of injections in CRPS management, the treating physician must carefully consider the inherent risks and benefits. First, it is understood that these injections are seldom meant to be “curative” but may have diagnostic or prognostic qualities and when used for therapeutic purposes they are employed in conjunction with other treatment modalities for maximum benefit. Second, education of the patient should include the proposed goals of the injections, expected gains, risks or complications, and alternative treatment. Lastly, reassessment of the patient's status in terms of functional improvement should be documented after each injection and/or series of injections.

a. Any continued use of injections should be monitored using objective measures such as:

- i. Return to work or maintaining work status.
- ii. Fewer restrictions at work or when performing activities of daily living (ADL).
- iii. Decrease in usage of medications.

iv. Measurable functional gains, such as increased range of motion or documented increase in strength.

(a). Visual analog scales (VAS) provide important subjective data but are not an appropriate measure of function.

(b). The physician must be aware of the possible placebo effect as well as the long-term effects of injections related to the patient's physical and mental status. Strict adherence to contraindications, both absolute and relative, may prevent potential complications. Subjecting the patient to potential risks, i.e., needle trauma, infection, nerve injury, or systemic effects of local anesthetics and corticosteroids, must be considered before the patient consents to such procedures.

b. Sympathetic Injections:

i. Description. Sympathetic injections are generally accepted, well-established procedures. They include stellate ganglion blocks, Kuntz Fiber blocks, thoracic sympathetic blocks, lumbar sympathetic, and intravenous regional (Bier) blocks. Regional blocks frequently use bretylium with additional agents (narcotics and or anti-inflammatory drugs). There is some evidence that bretylium reduces pain intensity. It is recommended that all patients receiving therapeutic blocks participate in PT and/or OT immediately after each block as well as in an appropriate exercise program that may include a functionally directed rehabilitation program.

ii. Indications. Pain relief and functional improvement from previous diagnostic or therapeutic blocks.

iii. Special Considerations. Except for Bier blocks, fluoroscopic and/or CT guidance during procedures is recommended to document technique and needle placement; an experienced physician should perform the procedure. The practitioner should participate in ongoing injection training workshops provided by organizations such as the American Society of Interventional Pain Physicians (ASIPP) and the Spinal Intervention Society (SIS) and be knowledgeable in radiation safety. In addition, practitioners should obtain fluoroscopy training and radiation safety credentialing from their Departments of Radiology, as applicable.

iv. Complications may include transient neurapraxia, nerve injury, inadvertent spinal injection, infection, venous or arterial vertebral puncture, laryngeal paralysis, respiratory arrest, vasovagal effects, as well as permanent neurologic damage.

v. Contraindications. Absolute contraindications of therapeutic injections include:

(a). bacterial infection – systemic or localized to region of injection,

(b). bleeding diatheses,

(c). hematological conditions, and

(d). possible pregnancy. Relative contraindications of therapeutic injections may include:

aspirin/antiplatelet therapy (drug may be held for at least 3 days prior to injection).

vi. Treatment Parameters. To be effective as a treatment modality, the patient should be making measurable progress in their rehabilitation program and should be achieving an increasing or sustained duration of relief between blocks. If appropriate outcomes are not achieved, changes in treatment should be undertaken.

(a). Time to produce effect: one to three blocks

(b). Frequency: Variable, depending upon duration of pain relief and functional gains. During the first two weeks of treatment, blocks may be provided every three to five days, based on patient response. After the first two weeks, blocks may be given weekly with tapering for a maximum of seven injections over six weeks. If pain relief and functional gains plateau before seven injections in six weeks, a trial of spinal cord or DRG spinal stimulation should be considered. Refer to chronic pain guidelines for treatment parameters.

(c). Optimum duration: three months.

(d). Maximum duration: three to four months for initial treatment. For the use of blocks during maintenance care, refer to the Maintenance Care section for treatment parameters.

(e). Trigger Point Injections: May be appropriate when myofascial trigger points are present on examination. Refer to chronic pain guidelines for treatment parameters.

(f). Peripheral Nerve Blocks: May be appropriate when peripheral nerve pathology is identified. Refer to chronic pain guidelines for treatment parameters.

(g). Intravenous lidocaine: May be used as a prognostic indicator for the use of mexilitine. It is infrequently used as a therapeutic treatment.

vii. Radiofrequency Sympathectomy in CRPS

(a). Thoracic, Lumbar and Sacral sympathetic ganglia, including Kuntz Fibers, Splanchnic Ganglia, sacral and L5 sympathetic ganglia, can be treated with RF ablation after successful diagnostic blocks with at least 50 percent relief of pain and improved function. This procedure can be repeated no more than every 6 months.

5. Interdisciplinary rehabilitation programs are the gold standard of treatment for individuals with chronic pain who have not responded to less intensive modes of treatment. In addition, there are current studies to support the use of pain programs. There is strong evidence that interdisciplinary programs improve function in chronic pain and moderate evidence that these programs decrease pain in these patients.

a. These programs should assess the impact of pain and suffering on the patient's medical, physical, psychological, social, and/or vocational functioning. In general, interdisciplinary programs deal with irreversible, painful musculoskeletal, neurological, and other chronic painful disorders and psychological issues, including drug

dependence, high levels of stress and anxiety, failed surgery and pre-existing or latent psychopathology. The number of professions involved in the team in a chronic pain program may vary due to the complexity of the needs of the person served. The OWCA recommends consideration of referral to an interdisciplinary program within 6 months post-injury in patients with delayed recovery unless surgical interventions or other medical complications intervene.

b. Chronic pain patients need to be treated within a continuum of treatment intensity. Chronic pain programs are available with services provided by a coordinated interdisciplinary team within the same facility (formal) or as coordinated by the authorized treating physician (informal). Formal programs are able to provide coordinated, high intensity level of services and are recommended for most chronic pain patients who have received multiple therapies during acute management. Informal programs offer a lesser intensity of service and may be considered for patients who are currently employed, those who cannot attend all day programs, those with language barriers, or those living in areas not offering formal programs. Before treatment has been initiated, the patient, physician, and insurer should agree on treatment approach, methods, and goals. Generally the type of program needed will depend on the degree of impact the pain has had on the patient's medical, physical, psychological, social and/or vocational functioning.

c. Inpatient pain rehabilitation programs are rarely needed but may be necessary for patients with any of the following conditions: High risk for medical instability; Moderate to severe impairment of physical/functional status; Moderate to severe pain behaviors; Moderate impairment of cognitive and/or emotional status; Dependence on medications from which he or she needs to be withdrawn; and the need for 24-hour supervised nursing.

d. Interdisciplinary pain programs, whether formal or informal, should be comprised of the following dimensions:

i. Communication. To ensure positive functional outcomes, communication between the patient, insurer and all professionals involved must be coordinated and consistent. Any exchange of information must be provided to all professionals, including the patient. Care decisions would be communicated to all.

ii. Documentation. Through documentation by all professionals involved and/or discussions with the patient, it should be clear that functional goals are being actively pursued and measured on a regular basis to determine their achievement or need for modification.

iii. Treatment Modalities. Use of modalities may be necessary early in the process to facilitate compliance with and tolerance to therapeutic exercise, physical conditioning, and increasing functional activities. Active treatments should be emphasized over passive treatments. Active treatments should encourage self-coping skills and management of pain, which can be continued independently at home or at work. Treatments that can foster a sense of dependency by the patient on the caregiver should be

avoided. Treatment length should be decided based upon observed functional improvement. For a complete list of Active and Passive Therapies, refer to those Subparagraphs of this guideline. All treatment timeframes may be extended based upon the patient's positive functional improvement.

iv. Therapeutic Exercise Programs. There is strong evidence that these programs, including aerobic conditioning and strengthening, are superior to treatment programs that do not include exercise. There is no sufficient evidence to support the recommendation of any particular exercise regimen over any other exercise regimen. A therapeutic exercise program should be initiated at the start of any treatment rehabilitation. Such programs should emphasize education, independence, and the importance of an on-going exercise regime.

v. Return-to-Work. The authorized treating physician should continually evaluate the patient for their potential to return to work. When return-to-work is an option, it may be appropriate to implement a Work Hardening Program (as described in this Section). For patients currently employed, efforts should be aimed at keeping them employed. For more specific information regarding return-to-work, refer to the Return-to-work section in this guideline.

vi. Patient Education. Patients with pain need to re-establish a healthy balance in lifestyle. All providers should educate patients on how to overcome barriers to resuming daily activity, including pain management, decreased energy levels, financial constraints, decreased physical ability, and change in family dynamics.

vii. Psychosocial Evaluation and Treatment. Psychosocial evaluation should be initiated, if not previously done. Providers of care should have a thorough understanding of the patient's personality profile; especially if dependency issues are involved. Psychosocial treatment may enhance the patient's ability to participate in pain treatment rehabilitation, manage stress, and increase their problem-solving and self-management skills.

viii. Vocational Assistance. Vocational assistance can define future employment opportunities or assist patients in obtaining future employment. Refer to Return-to-work section for detailed information.

e. Interdisciplinary programs are characterized by a variety of disciplines that participate in the assessment, planning, and/or implementation of the treatment program. These programs are for patients with greater levels of perceived disability, dysfunction, de-conditioning and psychological involvement. The following programs are listed in order of decreasing intensity.

i. Formal Rehabilitation Programs

(a) Interdisciplinary Pain Rehabilitation. An Interdisciplinary Pain Rehabilitation Program provides outcomes-focused, coordinated, goal-oriented interdisciplinary team services to measure and improve the functioning of persons with pain and encourage their appropriate use of health care system and services. The

## LABOR AND EMPLOYMENT

program can benefit persons who have limitations that interfere with their physical, psychological, social, and/or vocational functioning. The program shares information about the scope of the services and the outcomes achieved with patients, authorized providers, and insurers.

(b). The interdisciplinary team maintains consistent integration and communication to ensure that all interdisciplinary team members are aware of the plan of care for the patient, are exchanging information, and implement the plan of care. The team members make interdisciplinary team decisions with the patient and then ensure that decisions are communicated to the entire care team.

(c). The medical director of the pain program should be board certified in his or her specialty area, have at least two years full-time experience in an interdisciplinary pain rehabilitation program, and ideally be board certified in pain management. Individuals who assist in the accomplishment of functional, physical, psychological, social and vocational goal must include, at the least, a medical director, pain physician(s), psychologist, Biofeedback Therapist, Occupational Therapist, Physical Therapist, and Registered Nurse. Other disciplines on the team may include, but are not limited to, case manager, exercise physiologist, psychiatrist, and/or nutritionist.

(i). time to produce effect: three to four weeks;

(ii). frequency: No less than five hours/day, five days/week;

(iii). optimum duration: three to four weeks five times a week, followed by six to nine weeks of follow-up one to three times a week;

(iv). maximum duration: four months, including follow-up. Periodic review and monitoring thereafter on an as needed basis, is founded upon the documented maintenance of functional gains.

(d). Work hardening is an interdisciplinary program addressing a patient's employability and return-to-work. It includes a progressive increase in the number of hours per day that a patient completes work simulation tasks until the patient can tolerate a full workday. A full workday is case specific and is defined by the previous employment of the patient. This is accomplished by addressing the medical, psychological, behavioral, physical, functional, and vocational components of employability and return-to-work.

(e). The interdisciplinary team should, at a minimum, be comprised of a qualified medical director who is board certified with documented training in occupational rehabilitation, team physicians having experience in occupational rehabilitation, occupational therapy, physical therapy, case manager, and psychologist. As appropriate, the team may also include: chiropractor, RN, or vocational specialist.

(i). time to produce effect: two weeks;

(ii). frequency: two to five visits per week, up to eight hours/day;

(iii). optimum duration: two to four weeks;

(iv). maximum duration: six weeks.

Participation in a program beyond six weeks must be documented with respect to need and the ability to facilitate positive symptomatic or functional gains.

ii. Informal Rehabilitation Program. A coordinated interdisciplinary pain rehabilitation program is one in which the authorized treating physician coordinates all aspects of care. This type of program is similar to the formal programs in that it is goal oriented and provides interdisciplinary rehabilitation services to manage the needs of the patient in the following areas: functional, medical, physical, psychological, social, and vocational.

(a). This program is different from a formal program in that it involves lesser frequency and intensity of services/treatment. Informal rehabilitation is geared toward those patients who do not need the intensity of service offered in a formal program or who cannot attend an all-day program due to employment, daycare, language or other barriers.

(b). Patients should be referred to professionals experienced in outpatient treatment of chronic pain. The OWCA recommends the authorized treating physician consult with physicians experienced in the treatment of chronic pain to develop the plan of care.

(i). time to produce effect: three to eight weeks;

(ii). frequency: two to six hours per day, two to five days each week;

(iii). optimum duration: 6 to 12 weeks, including follow-up;

(iv). maximum duration: four months, including follow-up. Periodic review and monitoring thereafter on an as needed basis, is founded upon the documented maintenance of functional gains.

6. Medications. There is no single formula for pharmacological treatment of patients with chronic nonmalignant pain. A thorough medication history, including use of alternative and over the counter medications, should be performed at the time of the initial visit and updated periodically. Appropriate application of pharmacological agents depends on the patient's age, past history (including history of substance abuse), drug allergies, and the nature of all medical problems. It is incumbent upon the physician to thoroughly understand pharmacological principles when dealing with the different drug families and their respective side effect, bioavailability profiles and primary reason for each medication's usage.

a. Control of chronic non-malignant pain is expected to involve the use of medication. Strategies for pharmacological control of pain cannot be precisely specified in advance. Rather, drug treatment requires close monitoring of the patient's response to therapy, flexibility on the part of the prescriber, and a willingness to change treatment when circumstances change. Many of the drugs

discussed in the medication section were licensed for indications other than analgesia, but are effective in the control of many types of chronic pain.

b. All medications should be given an appropriate trial in order to test for therapeutic effect. Trials of medication requiring specific therapeutic drug levels may take several months to achieve, depending upon the half-life of the drug. It is recommended that patients with CRPS be maintained on drugs that have the least serious side effects. For example, patients need to be tried or continued on acetaminophen and or antidepressant medications whenever feasible as part of their overall treatment for chronic pain. It is recommended that use of opioid analgesic and sedative hypnotic medications in chronic pain patients be used in a very limited manner, with total elimination desirable whenever clinically feasible. See Chronic Pain Medication Section for further guidance.

c. For the clinician to interpret the following material, it should be noted that: drug profiles listed are not complete; dosing of drugs will depend upon the specific drug, especially for off-label use; and not all drugs within each class are listed, and other drugs within the class may be appropriate for individual cases. Clinicians should refer to informational texts or consult a pharmacist before prescribing unfamiliar medications or when there is a concern regarding drug interactions.

d. The following drug classes are listed in alphabetical order, not in order of suggested use.

i. Anticonvulsants. Although the mechanism of action of anticonvulsant drugs in neuropathic pain states remains to be fully defined, they appear to act as channel blocking agents. A large variety of sodium channels are present in nervous tissue, and some of these are important mediators of nociception, as they are found primarily in unmyelinated fibers and their density increases following nerve injury. While the pharmacodynamic effects of the various anticonvulsant drugs are similar, the pharmacokinetic effects differ significantly. Gabapentin and pregabalin, by contrast, are relatively non-significant enzyme inducers, creating fewer drug interactions. All patients on these medications should be monitored for suicidal ideation. Many of these medications are not recommended for women of child-bearing age due to possible teratogenic effects.

(a). Gabapentin and pregabalin are commonly prescribed for neuropathic pain. There is an association between older anticonvulsants including gabapentin and non-traumatic fractures for patients older than 50; this should be taken into account when prescribing these medications.

(b). Gabapentin and pregabalin have indirect (not GABA A or GABA B receptor mediated) GABA-mimetic qualities rather than receptor mediated actions. This can potentially result in euphoria, relaxation, and sedation. It is likely that they also affect the dopaminergic "reward" system related to addictive disorders. Misuse of these medications usually involves doses 3 to 20 times that of the usual therapeutic dose. The medication is commonly used

with alcohol or other drugs of abuse. Providers should be aware of the possibility and preferably screen patients for abuse before prescribing these medications. Withdrawal symptoms, such as insomnia, nausea, headache, or diarrhea, are likely when high doses of pregabalin have been used. Tolerance can also develop.

(c). Gabapentin (Fanatrex, Gabarone, Gralise, Horizant, Neurontin)

(i). Description—Structurally related to gamma aminobutyric acid (GABA) but does not interact with GABA receptors. Gabapentin affects the alpha-2-delta-1 ligand of voltage gated calcium channels, thus inhibiting neurotransmitter containing intra-cellular vesicles from fusing with the pre-synaptic membranes and reducing primary afferent neuronal release of neurotransmitters (glutamate, CGRP, and substance P). It may also modulate transient receptor potential channels, NMDA receptors, protein kinase C and inflammatory cytokines, as well as possibly stimulating descending norepinephrine mediated pain inhibition.

(ii). Indications—As of the time of this guideline writing, formulations of gabapentin have been FDA approved for post-herpetic neuralgia and partial onset seizures.

[a]. There is strong evidence that gabapentin is more effective than placebo in the relief of painful diabetic neuropathy and post-herpetic neuralgia.

[b]. There is some evidence that gabapentin may benefit some patients with post-traumatic neuropathic pain. There is good evidence that gabapentin is not superior to amitriptyline. There is some evidence that nortriptyline (Aventyl, Pamelor) and gabapentin are equally effective for pain relief of postherpetic neuralgia. There is some evidence that the combination of gabapentin and morphine may allow lower doses with greater analgesic effect than the drugs given separately. There is strong evidence that gabapentin is more effective than placebo for neuropathic pain, even though it provides complete pain relief to a minority of patients. There is some evidence that a combination of gabapentin and nortriptyline provides more effective pain relief than monotherapy with either drug.

(iii). Relative Contraindications—Renal insufficiency. Dosage may be adjusted to accommodate renal dysfunction.

(iv). Dosing and Time to Therapeutic Effect—Dosage should be initiated at a low dose in order to avoid somnolence and may require four to eight weeks for titration. Dosage should be adjusted individually. It is taken three to four times per day, and the target dose is 1800 mg.

(v). Major Side Effects—Confusion, sedation, dizziness, peripheral edema. Patients should also be monitored for suicidal ideation and drug abuse.

(vi). Drug Interactions—antacids.

(vii). Laboratory Monitoring—Renal function.

ii. Antidepressants are classified into a number of categories based on their chemical structure and their effects on neurotransmitter systems. Their effects on depression are attributed to their actions on disposition of norepinephrine and serotonin at the level of the synapse; although these synaptic actions are immediate, the symptomatic response in depression is delayed by several weeks. When used for chronic pain, the effects may in part arise from treatment of underlying depression, but may also involve additional neuromodulatory effects on endogenous opioid systems, raising pain thresholds at the level of the spinal cord.

(a). Pain responses may occur at lower drug doses with shorter times to symptomatic response than are observed when the same compounds are used in the treatment of mood disorders. Neuropathic pain, diabetic neuropathy, post-herpetic neuralgia, and cancer-related pain may respond to antidepressant doses low enough to avoid adverse effects that often complicate the treatment of depression. First line drugs for neuropathic pain are the tricyclics with the newer formulations having better side effect profiles. SNRIs are considered second line drugs due to their costs and the number needed to treat for a response. Duloxetine may be considered for first line use in a patient who is a candidate for pharmacologic treatment of both chronic pain and depression. SSRIs are used generally for depression rather than neuropathic pain and should not be combined with moderate to high-dose tricyclics.

(b). All patients being considered for antidepressant therapy should be evaluated and continually monitored for suicidal ideation and mood swings.

(i). Tricyclics and Older Agents (e.g., amitriptyline, nortriptyline, doxepin [Silenor, Sinequan, Adapin], desipramine [Norpramin, Pertofrane], imipramine [Tofranil], trazodone [Desyrel, Oleptro])

[a]. Description—Serotonergics, typically tricyclic antidepressants (TCAs), are utilized for their serotonergic properties as increasing CNS serotonergic tone can help decrease pain perception in non-antidepressant dosages. TCAs decrease reabsorption of both serotonin and norepinephrine. They also impact Na channels. Amitriptyline is known for its ability to repair Stage 4 sleep architecture, a frequent problem found in chronic pain patients and to treat depression, frequently associated with chronic pain. However, higher doses may produce more cholinergic side effects than newer tricyclics such as nortriptyline and desipramine. Doxepin and trimipramine also have sedative effects.

[i]. There is some evidence that a combination of some gabapentin and nortriptyline provides more effective pain relief than monotherapy with either drug, without increasing side effects of either drug.

[b]. Indications—Some formulations are FDA approved for depression and anxiety. For the purposes of this guideline, they are recommended for neuropathic pain and insomnia. They are not recommended as a first line drug treatment for depression.

[c]. Major Contraindications—Cardiac disease or dysrhythmia, glaucoma, prostatic hypertrophy, seizures, high suicide risk, uncontrolled hypertension and orthostatic hypotension. A screening cardiogram may be done for those 40 years of age or older, especially if higher doses are used. Caution should be utilized in prescribing TCAs. They are not recommended for use in elderly patients 65 years of age or older, particularly if they are at fall risk.

[d]. Dosing and Time to Therapeutic Effect—Varies by specific tricyclic. Low dosages, less than 100 mg, are commonly used for chronic pain and/or insomnia. Lower doses decrease side effects and cardiovascular risks.

[e]. Major Side Effects—Side effects vary according to the medication used; however, the side effect profile for all of these medications is generally higher in all areas except GI distress, which is more common among the SSRIs and SNRIs. Anticholinergic side effects including, but not limited to, dry mouth, sedation, orthostatic hypotension, cardiac arrhythmia, urinary retention, and weight gain. Dry mouth leads to dental and periodontal conditions (e.g., increased cavities). Patients should also be monitored for suicidal ideation and drug abuse. Anticholinergic side effects are more common with tertiary amines (amitriptyline, imipramine, doxepin) than with secondary amines (nortriptyline and desipramine).

[f]. Drug Interactions—Tramadol (may cause seizures, both also increase serotonin/norepinephrine, so serotonin syndrome is a concern), clonidine, cimetidine (Tagamet), sympathomimetics, valproic acid (Depakene, Depakote, Epilim, Stavzor), warfarin (Coumadin, Jantoven, Marfarin), carbamazepine, bupropion (Aplezin, Budeprion, Buproban, Forfivo, Wellbutrin, Zyban), anticholinergics, quinolones.

[g]. Recommended Laboratory Monitoring—Renal and hepatic function. Electrocardiogram (EKG) for those on high dosages or with cardiac risk.

iii. Reserved.

iv. Opioids are the most powerful analgesics. Their use in acute pain and moderate-to-severe cancer pain is well accepted. Their use in chronic nonmalignant pain, however, is fraught with controversy and lack of scientific research. Deaths in the United States from opioids have escalated in the last 15 years. The CDC states the following in their 2016 Primary Care guideline for prescribing opioids: Opioid pain medication use presents serious risk, including overdose and opioid use disorder. From 1999 to 2014, more than 165,000 persons died from overdose related to opioid pain medication in the United States. In the past decade, while the death rates for the top leading causes of death such as heart disease and cancer have decreased substantially, the death rate associated with opioid pain medication has increased markedly. Sales of opioid pain medication have increased in parallel with opioid-related overdose deaths. The Drug Abuse Warning Network estimated that less than 420,000 emergency department visits were related to the misuse or abuse of narcotic pain relievers in 2011, the most



recent year for which data are available. Opioid poisoning has also been identified in work-related populations.

(a). Effectiveness and Side Effects: Opioids include some of the oldest and most effective drugs used in the control of severe pain. The discovery of opioid receptors and their endogenous peptide ligands has led to an understanding of effects at the binding sites of these naturally occurring substances. Most of their analgesic effects have been attributed to their modification of activity in pain pathways within the central nervous system; however, it has become evident that they also are active in the peripheral nervous system. Activation of receptors on the peripheral terminals of primary afferent nerves can mediate anti-nociceptive effects, including inhibition of neuronal excitability and release of inflammatory peptides. Some of their undesirable effects on inhibiting gastrointestinal motility are peripherally mediated by receptors in the bowel wall.

(i). Most studies show that only around 50 percent of patients tolerate opioid side effects and receive an acceptable level of pain relief. Depending on the diagnosis and other agents available for treatment, the incremental benefit can be small.

(ii). There is good evidence that opioids are more efficient than placebo in reducing neuropathic pain by clinically significant amounts. There is a lack of evidence that opioids improve function and quality of life more effectively than placebo. There is good evidence that opioids produce significantly more adverse effects than placebo such as constipation, drowsiness, dizziness, nausea, and vomiting. There is a lack of evidence that they are superior to gabapentin or nortriptyline for neuropathic pain reduction.

(iii). Patients should have a thorough understanding of the need to pursue many other pain management techniques in addition to medication use in order to function with chronic pain. They should also be thoroughly aware of the side effects and how to manage them. There is strong evidence that adverse events such as constipation, dizziness, and drowsiness are more frequent with opioids than with placebo. Common side effects are drowsiness, constipation, nausea, and possible testosterone decrease with longer term use.

(b). Hyperalgesia: Administration of opioid analgesics leads not only to analgesia, but may also lead to a paradoxical sensitization to noxious stimuli. Opioid induced hyperalgesia has been demonstrated in animals and humans using electrical or mechanical pain stimuli. This increased sensitivity to mildly painful stimuli does not occur in all patients and appears to be less likely in those with cancer, clear inflammatory pathology, or clear neuropathic pain. When hyperalgesia is suspected, opioid tapering is appropriate.

(c). Opioid Induced Constipation (OIC): Some level of constipation is likely ubiquitous among chronic opioid users. An observational study of chronic opioid users who also used some type of laxative at least four times per week noted that approximately 50 percent of the patients

were dissatisfied and they continue to report stool symptoms. 71 percent used a combination of natural and dietary treatment, 64.3 percent used over-the-counter laxatives, and 30 percent used prescription laxatives. Other studies report similar percentages. There are insufficient quality studies to recommend one specific type of laxative over others.

(i). The easiest method for identifying constipation, which is also recommended by a consensus, multidisciplinary group, is the Bowel Function Index. It assesses the patient's impression over the last seven days for ease of defecation, feeling of incomplete bowel evacuation, and personal judgment re-constipation.

(ii). Stepwise treatment for OIC is recommended, and all patients on chronic opioids should receive information on treatment for constipation. Dietary changes increasing soluble fibers are less likely to decrease OIC and may cause further problems if GI motility is decreased. Stool softeners may be tried, but stimulant and osmotic laxatives are likely to be more successful. Osmotic laxatives include lactulose and polyethylene glycol. Stimulants include bisacodyl, sennosides, and sodium picosulfate, although there may be some concern regarding use of stimulants on a regular basis.

(iii). Opioid rotation or change in opioids may be helpful for some patients. It is possible that sustained release opioid products cause more constipation than short acting agents due to their prolonged effect on the bowel opioid receptors. Tapentadol is a  $\mu$ -opioid agonist and norepinephrine reuptake inhibitor. It is expected to cause less bowel impairment than oxycodone or other traditional opioids. Tapentadol may be the preferred opioid choice for patients with OIC.

(iv). Other prescription medications may be used if constipation cannot adequately be controlled with the previous measures. Naloxegol is a pegylated naloxone molecule that does not pass the blood brain barrier and thus can be given with opioid therapy. There is good evidence that it can alleviate OIC and that 12.5 mg starting dose has an acceptable side effect profile.

(v). Methylnaltrexone does not cross the blood brain barrier and can be given subcutaneously or orally. It is specifically recommended for opioid induced constipation for patients with chronic non-cancer pain.

(vi). Misoprostol is a synthetic prostaglandin E1 agonist and has the side effect of diarrhea in some patients. It also has been tried for opioid induced constipation, although it is not FDA approved for this use.

(vii). Naldemedine is an opioid antagonist indicated for the treatment of opioid-induced

constipation in adult patients with chronic pain.

(viii). Lubiprostone is a prostaglandin E1 approved for use in opioid constipation.

(ix). Most patients will require some therapeutic control for their constipation. The stepwise

treatment discussed should be followed initially. If that has failed and the patient continues to have recurrent problems with experiencing severe straining, hard or lumpy stool with incomplete evacuation, or infrequent stools for 25 percent of the time despite the more conservative measures, it may be appropriate to use a pharmaceutical agent.

(d). **Physiologic Responses to Opioids.** Physiologic responses to opioids are influenced by variations in genes which code for opiate receptors, cytochrome P450 enzymes, and catecholamine metabolism. Interactions between these gene products significantly affect opiate absorption, distribution, and excretion. Hydromorphone, oxycodone, and morphine are metabolized through the glucuronide system. Other opioids generally use the cytochrome P450 system. Allelic variants in the mu opiate receptor may cause increased analgesic responsiveness to lower drug doses in some patients. The genetic type can predict either lower or higher needs for opioids. For example, at least 10 percent of Caucasians lack the CYP450 2D6 enzyme that converts codeine to morphine. In some cases, genetic testing for cytochrome P450 type may be helpful. When switching patients from codeine to other medications, assume the patient has little or no tolerance to opioids. Many gene-drug associations are poorly understood and of uncertain clinical significance. The treating physician needs to be aware of the fact that the patient's genetic makeup may influence both the therapeutic response to drugs and the occurrence of adverse effects. A Comprehensive genetic testing panel may be ordered by treating physician for these multiple P450 genes once in a lifetime and utilized whenever there is a question of metabolism or unusual response of any drugs used to treat pain conditions, because multiple drugs and associated genes can cause problems with opioid metabolism

(e). **Adverse Events.** Physicians should be aware that deaths from unintentional drug overdoses exceed the number of deaths from motor vehicle accidents in the US. Most of these deaths are due to the use of opioids, usually in combination with other respiratory depressants such as alcohol or benzodiazepines. The risk for out of hospital deaths not involving suicide was also high. The prevalence of drug abuse in the population of patients undergoing pain management varies according to region and other issues. One study indicated that one-fourth of patients being monitored for chronic opioid use have abused drugs occasionally, and one-half of those have frequent episodes of drug abuse. 80 percent of patients admitted to a large addiction program reported that their first use of opioids was from prescribed medication.

(i). There is good evidence that in generally healthy patients with chronic musculoskeletal pain, treatment with long-acting opioids, compared to treatments with anticonvulsants or antidepressants, is associated with an increased risk of death of approximately 69 percent, most of which arises from non-overdose causes, principally cardiovascular in nature. The excess cardiovascular mortality principally occurs in the first 180 days from starting opioid treatment.

(ii). There is some evidence that compared to an opioid dose under 20 MED per day, a dose of 20-50 mg nearly doubles the risk of death, a dose of 50 to 100 mg may increase the risk more than fourfold, and a dose greater than 100 mg per day may increase the risk as much as sevenfold. However, the absolute risk of fatal overdose in chronic pain patients is fairly low and may be as low as 0.04 percent. There is good evidence that prescription opioids in excess of 200 MED average daily doses are associated with a near tripling of the risk of opioid-related death, compared to average daily doses of 20 MED. Average daily doses of 100-200 mg and doses of 50-99 mg per day may be associated with a doubling of mortality risk, but these risk estimates need to be replicated with larger studies.

(iii). Doses of opioids in excess of 120 MED have been observed to be associated with increased duration of disability. Higher doses are more likely to be associated with hypo-gonadism, and the patient should be informed of this risk. Higher doses of opioids also appear to contribute to the euphoric effect. The CDC recommends Primary Care Practitioners limiting to 90 MED per day to avoid increasing risk of overdose or referral to a pain specialist.

(iv). In summary, there is strong evidence that any dose above 50 MED per day is associated with a higher risk of death and 100 mg or greater appears to significantly increase the risk. Interventional techniques such as spinal cord stimulation or intrathecal catheters and programmable pumps should be considered in order to stop oral opioids usage.

(v). Workers who eventually are diagnosed with opioid abuse after an injury are also more likely to have higher claims cost. A retrospective observational cohort study of workers' compensation and short-term disability cases found that those with at least one diagnosis of opioid abuse cost significantly more in days lost from work for both groups and in overall healthcare costs for the short-term disability groups. About 0.5 percent of eligible workers were diagnosed with opioid abuse.

(f). **Dependence versus Addiction.** The central nervous system actions of these drugs account for much of their analgesic effect and for many of their other actions, such as respiratory depression, drowsiness, mental clouding, reward effects, and habit formation. With respect to the latter, it is crucial to distinguish between two distinct phenomena: dependence and addiction.

(i). Dependence is a physiological tolerance and refers to a set of disturbances in body homeostasis that leads to withdrawal symptoms, which can be produced with abrupt discontinuation, rapid reduction, decreasing blood levels, and/or by administration of an antagonist.

(ii). Addiction is a primary, chronic, neurobiological disease, with genetic, psychological, and environmental factors influencing its development and manifestations. It is a behavioral pattern of drug craving and seeking which leads to a preoccupation with drug procurement and an aberrant pattern of use. The drug use is frequently associated with negative consequences.

(iii). Dependence is a physiological phenomenon, which is expected with the continued administration of opioids, and need not deter physicians from their appropriate use. Before increasing the opioid dose, the physician should review other possible causes for the decline in analgesic effect. Increasing the dose may not result in improved function or decreased pain. Remember that it is recommended for total morphine milligram equivalents (MME) per day to remain at 50 or below. Consideration should be given to possible new psychological stressors or an increase in the activity of the nociceptive pathways. Other possibilities include new pathology, low testosterone level that impedes delivery of opioids to the central nervous system, drug diversion, hyperalgesia, or abusive use of the medication.

(g). Choice of Opioids. No long-term studies establish the efficacy of opioids over one year of use or superior performance by one type. There is no evidence that one long-acting opioid is more effective than another, or more effective than other types of medications, in improving function or pain. There is some evidence that long-acting oxycodone (Dazidox, Endocodone, ETH-oxycodone, Oxycontin, Oxyfast, OxyIR, Percolone, Roxicodone) and oxymorphone have equal analgesic effects and side effects, although the milligram dose of oxymorphone (Opana) is one-half that of oxycodone. There is no evidence that long-acting opioids are superior to short-acting opioids for improving function or pain or causing less addiction. A number of studies have been done assessing relief of pain in cancer patients. A recent systematic review concludes that oxycodone does not result in better pain relief than other strong opioids including morphine and oxymorphone. It also found no difference between controlled release and immediate release oxycodone. There is some evidence that extended release hydrocodone has a small and clinically unimportant advantage over placebo for relief of chronic low back pain among patients who are able to tolerate the drug and that 40 percent of patients who begin taking the drug do not attain a dose which provides pain relief without unacceptable adverse effects. Hydrocodone ER does not appear to improve function in comparison with placebo. A Cochrane review of oxycodone in cancer pain also found no evidence in favor of the longer acting opioid. There does not appear to be any significant difference in efficacy between once daily hydromorphone and sustained release oxycodone. Nausea and constipation are common for both medications between 26 to 32 percent. November 21, 2017, the FDA Commissioner, Scott Gottlieb, M.D., issued a Statement to promote development of generic versions of opioids formulated to deter abuse. One year earlier the FDA issued a statement encouraging development of Abuse Deterrent Formulations for opioids as a meaningful health benefit designed to reduce opioid abuse in the U.S. and to potentially and eventually remove conventional non deterrent opioids from the market if found to be unsafe.

(i). There is some evidence that in the setting of neuropathic pain, a combination of morphine plus nortriptyline produces better pain relief than either monotherapy alone, but morphine monotherapy is not

superior to nortriptyline monotherapy, and it is possible that it is actually less effective than nortriptyline.

(ii). Long-acting opioids should not be used for the treatment of acute, sub-acute, or post-operative pain, as this is likely to lead to drug dependence and difficulty tapering the medication. Additionally, there is a potential for respiratory depression to occur. The FDA requires that manufacturers develop Risk Evaluation and Mitigation Strategies (REMS) for most opioids. Physicians should carefully review the plans or educational materials provided under this program. Clinical considerations should determine the need for long-acting opioids given their lack of evidence noted above.

(iii). Addiction and abuse potentials of commonly prescribed opioid drugs may be estimated in a variety of ways, and their relative ranking may depend on the measure which is used. One systematic study of prescribed opioids estimated rates of drug misuse were estimated at 21 to 29 percent and addiction at 8 to 12 percent. There is good evidence that in the setting of new onset chronic non-cancer pain, there is a clinically important relationship between opioid prescription and subsequent opioid use disorder. Compared to no opioid use, short-term opioid use approximately triples the risk of opioid use disorder in the next 18 months. Use of opioids for over 90 days is associated with very pronounced increased risks of the subsequent development of an opioid use disorder, which may be as much as one hundredfold when doses greater than 120 MED are taken for more than 90 days. The absolute risk of these disorders is very uncertain but is likely to be greater than 6.1 percent for long duration treatment with a high opioid dose. Pain physicians should be consulted when the MED reaches 100 to develop an updated treatment plan

(iv). Hydrocodone is the most commonly prescribed opioid in the general population and is one of the most commonly abused opioids in the population. However, the abuse rate per 1000 prescriptions is lower than the corresponding rates for extended release oxycodone, hydromorphone (Dilaudid, Palladone), and methadone. Extended release oxycodone appears to be the most commonly abused opioid, both in the general population and in the abuse rate per 1000 prescriptions. Tramadol, by contrast, appears to have a lower abuse rate than for other opioids.

(v). Types of opioids are listed below.

[a]. Buprenorphine: (various formulations) is prescribed as an intravenous injection, transdermal patch, buccal film, or sublingual tablet due to lack of bioavailability of oral agents. Depending upon the formulation, buprenorphine may be indicated for the treatment of pain or for the treatment of opioid dependence (addiction).

[i]. Buprenorphine for Opioid Dependence (addiction). FDA has approved a number of buccal films including those with naloxone and a sublingual tablet to treat opioid dependence (addiction).

[ii].Buprenorphine for Pain: The FDA has approved specific forms of an intravenous and subcutaneous injectable, transdermal patch, and a buprenorphine buccal film to treat pain. However, by law, the transdermal patch and the injectable forms cannot be used to treat opioid dependence (addiction), even by DATA-2000 waived physicians authorized to prescribe buprenorphine for addiction. Transdermal forms may cause significant skin reaction. Buprenorphine is not recommended for most chronic pain patients due to methods of administration, reports of euphoria in some patients, and lack of proof for improved efficacy in comparison with other opioids.

[iii].There is insufficient evidence to support or refute the suggestion that buprenorphine has any efficacy in any neuropathic pain condition.

[iv].There is good evidence transdermal buprenorphine is not inferior to oral tramadol in the treatment of moderate to severe musculoskeletal pain arising from conditions like osteoarthritis and low back pain. The population of patients for whom it is more appropriate than tramadol is not established but would need to be determined on an individual patient basis if there are clear reasons not to use oral tramadol. In a well-done study, 63 percent of those on buccal buprenorphine achieved a 30 percent or more decrease in pain at 12 weeks compared to a 47 percent placebo response. Approximately 40 percent of the initial groups eligible for the study dropped out during the initial phase when all patients received the drug to test for incompatibility.

[v].There is strong evidence that in patients being treated with opioid agonists for heroin addiction, methadone is more successful than buprenorphine at retaining patients in treatment. The rates of opiate use, as evidenced by positive urines, are equivalent between methadone and buprenorphine. There is strong evidence that buprenorphine is superior to placebo with respect to retention in treatment, and good evidence that buprenorphine is superior to placebo with respect to positive urine testing for opiates.

[vi].There is an adequate meta-analysis supporting good evidence that transdermal fentanyl and transdermal buprenorphine are similar with respect to analgesia and sleep quality, and they are similar with respect to some common adverse effects such as constipation and discontinuation due to lack of effect. However, buprenorphine probably causes significantly less nausea than fentanyl, and it probably carries a lower risk of treatment discontinuation due to adverse events. It is also likely that both transdermal medications cause less constipation than oral morphine.

[vii].Overall, due to cost and lack of superiority, buprenorphine is not a front line opioid choice. However, it may be used in those with a history of addiction or at high risk for addiction who otherwise qualify for chronic opioid use. It is also appropriate to consider buprenorphine products for tapering strategies and those on high dose morphine of 90 MED or more.

[b].Codeine with Acetaminophen: Some patients cannot genetically metabolize codeine and therefore have no response. Codeine is not generally used on a daily basis for chronic pain. Acetaminophen dose per day should be limited to 2 grams.

[c].Fentanyl (Actiq, Duragesic, Fentora, Sublimazem, Subsys) is not recommended for use with musculoskeletal chronic pain patients. It has been associated with a number of deaths and has high addiction potential. Fentanyl should never be used transbuccally in this population. If Fentanyl it is being considered for a very specific patient population, it requires support from a pain specialist. Subsys is only indicated for cancer pain.

[d].Meperidine (Demerol) is not recommended for chronic pain. It and its active metabolite, normeperidine, present a serious risk of seizure and hallucinations. It is not a preferred medication for acute pain as its analgesic effect is similar to codeine.

[e].Methadone requires special precautions given its unpredictably long half-life and non-linear conversion from other opioids such as morphine. It may also cause cardiac arrhythmias due to QT prolongation and has been linked with a greater number of deaths due to its prolonged half-life. No conclusions can be made regarding differences in efficacy or safety between methadone and placebo, other opioids, or other treatments. There is strong evidence that in patients being treated with opioid agonists for heroin addiction, methadone is more successful than buprenorphine at retaining patients in treatment. The rates of opiate use, as evidenced by positive urines, are equivalent between methadone and buprenorphine. Methadone should only be prescribed by those with experience in managing this medication. Conversion from another opioid to methadone (or the other way around) can be very challenging, and dosing titration must be done very slowly (no more than every seven days). Unlike many other opioids, it should not be used on an "as needed" basis, as decreased respiratory drive may occur before the full analgesic effect of methadone is appreciated. If methadone is being considered, genetic screening is appropriate. CYP2B6 polymorphism appears to metabolize methadone more slowly than the usual population and may cause more frequent deaths.

[f].Morphine may be used in the non-cancer pain population. A study in chronic low back pain suggested that individuals with a greater amount of endogenous opioids will have a lower pain relief response to morphine.

[g].Oxycodone and Hydromorphone: There is no evidence that oxycodone (as oxycodone CR) is of value in treating people with painful diabetic neuropathy, postherpetic neuralgia, or other neuropathic conditions. There was insufficient evidence to support or refute the suggestion that hydromorphone has any efficacy in any neuropathic pain condition. Oxycodone was not associated with greater pain relief in cancer patients when compared to morphine or oxymorphone.

[h].Propoxyphene (Darvon, Davon-N, PP-Cap) has been withdrawn from the market due to cardiac effects including arrhythmias.

[i].Tapentadol (Nucynta) is a mu opioid agonist which also inhibits serotonin and norepinephrine reuptake activity. It is currently available in an intermediate release formulation and may be available as extended release if FDA approved. Due to its dual activity, it can cause seizures or serotonin syndrome, particularly when taken with other SSRIs, SNRIs, tricyclics, or MAO inhibitors. It has not been tested in patients with severe renal or hepatic damage. It has similar opioid abuse issues as other opioid medication; however, it is promoted as having fewer GI side effects, such as constipation. There is good evidence that extended release tapentadol is more effective than placebo and comparable to oxycodone. In that study, the percent of patients who achieved 50 percent or greater pain relief was: placebo, 18.9 percent, tapentadol, 27.0 percent, and oxycodone, 23.3 percent. There is some evidence that tapentadol can reduce pain to a moderate degree in diabetic neuropathy, average difference 1.4/10 pain scale, with tolerable adverse effects. However, a high quality systematic review found inadequate evidence to support tapentadol to treat chronic pain. Tapentadol is not recommended as a first line opioid for chronic, subacute, or acute pain due to the cost and lack of superiority over other analgesics. There is some evidence that tapentadol causes less constipation than oxycodone. Therefore, it may be appropriate for patients who cannot tolerate other opioids due to GI side effects.

[j].Tramadol (Rybitx, Ryzolt, Ultram)

[i].Description: an opioid partial agonist that does not cause GI ulceration or exacerbate hypertension or congestive heart failure. It also inhibits the reuptake of norepinephrine and serotonin which may contribute to its pain relief mechanism. There are side effects similar to opioid side effects and may limit its use. They include nausea, sedation, and dry mouth.

[ii].Indications: mild to moderate pain relief. As of the time of this guideline writing, formulations of tramadol have been FDA approved for management of moderate to moderately severe pain in adults. This drug has been shown to provide pain relief equivalent to that of commonly prescribed NSAIDs. Unlike other pure opioids agonists, there is a ceiling dose to tramadol due to its serotonin activity (usually 300-400 mg per day). There is some evidence that it alleviates neuropathic pain following spinal cord injury. There is inadequate evidence that extended-release tramadol/acetaminophen in a fixed-dose combination of 75 mg/650 mg is more effective than placebo in relieving chronic low back pain; it is not more effective in improving function compared to placebo. There is some evidence that tramadol yields a short-term analgesic response of little clinical importance relative to placebo in post-herpetic neuralgia which has been symptomatic for approximately six months. However, given the effectiveness of other drug classes for neuropathic pain, tramadol should not be considered a first line medication. It may be useful for

patients who cannot tolerate tricyclic antidepressants or other medications.

[iii].Contraindications: use cautiously in patients who have a history of seizures, who are taking medication that may lower the seizure threshold, or taking medications that impact serotonin reuptake and could increase the risk for serotonin syndrome, such as monoamine oxidase inhibitors (MAO) inhibitors, SSRIs, TCAs, and alcohol. Use with caution in patients taking other potential QT prolonging agents. Not recommended in those with prior opioid addiction. Has been associated with deaths in those with an emotional disturbance or concurrent use of alcohol or other opioids. Significant renal and hepatic dysfunction requires dosage adjustment.

[iv].Side effects: may cause impaired alertness or nausea. This medication has physically addictive properties, and withdrawal may follow abrupt discontinuation.

[v].Drug interactions: opioids, sedating medications, any drug that affects serotonin and/or norepinephrine (e.g., SNRIs, SSRIs, MAOs, and TCAs).

[vi].Laboratory Monitoring: renal and hepatic function.

(vi). Health care professionals and their patients must be particularly conscientious regarding the potential dangers of combining over-the-counter acetaminophen with prescription medications that also contain acetaminophen. Opioid and acetaminophen combination medication are limited due to the acetaminophen component. Total acetaminophen dose per day should not exceed 4 grams per any 24-hour period and is preferably limited to 2 grams per day to avoid possible liver damage.

(vii). Indications. The use of opioids is well accepted in treating cancer pain, where nociceptive mechanisms are generally present due to ongoing tissue destruction, expected survival may be short, and symptomatic relief is emphasized more than functional outcomes. In chronic non-malignant pain, by contrast, tissue destruction has generally ceased, meaning that central and neuropathic mechanisms frequently overshadow nociceptive processes. Expected survival in chronic pain is relatively long, and return to a high-level of function is a major goal of treatment. Therefore, approaches to pain developed in the context of malignant pain may not be transferable to chronic non-malignant pain. Opioids are generally not the best choice of medication for controlling neuropathic pain. Tricyclics, SNRIs, and anticonvulsants should be tried before considering opioids for neuropathic pain.

[a]. In most cases, analgesic treatment should begin with acetaminophen, aspirin, NSAIDs, and possibly Baclofen or Tizanidine. While maximum efficacy is modest, they may reduce pain sufficiently to permit adequate function. When these drugs do not satisfactorily reduce pain, medications specific to the diagnosis should be used (e.g.,

neuropathic pain medications as outlined in Section G.10, Medications).

[b]. There is good evidence from a prospective cohort study that in the setting of common low back injuries, when baseline pain and injury severity are taken into account, a prescription for more than seven days of opioids in the first six weeks is associated with an approximate doubling of disability one year after the injury. Therefore, prescribing after two weeks in a non-surgical case requires a risk assessment. If prescribing beyond four weeks, a full opioid trial is suggested including toxicology screen. Best practice suggests that whenever there is use of opioids for more than seven days, providers should follow all recommendations for screening and follow-ups of chronic pain use.

[c]. Consultation or referral to a pain specialist behavioral therapist should be considered when the pain persists but the underlying tissue pathology is minimal or absent and correlation between the original injury and the severity of impairment is not clear. Consider consultation if suffering and pain behaviors are present and the patient manifests risk behaviors described below, or when standard treatment measures have not been successful or are not indicated.

[d]. A psychological consultation including psychological testing (with validity measures) is indicated for all chronic pain patients as these patients are at high risk for unnecessary procedures and treatment and prolonged recovery.

[e]. Many behaviors have been found related to prescription-drug abuse patients. None of these are predictive alone, and some can be seen in patients whose pain is not under reasonable control; however, the behaviors should be considered warning signs for higher risk of abuse or addiction by physicians prescribing chronic opioids. Refer to Subsection, High Risk Behavior, below.

(ix). Recommendations for Opioid Use. When considering opioid use for moderate to moderately severe chronic pain, a trial of opioids must be accomplished as described below and the patient must have failed other chronic pain management regimes. Physicians should complete the education recommended by the FDA, risk evaluation and mitigation strategies (REMS) provided by drug manufacturing companies.

[a]. General Indications. There must be a clear understanding that opioids are to be used for a limited term in the first instance (see trial indications below). The patient should have a thorough understanding of all of the expectations for opioid use. The level of pain relief is expected to be relatively small, two to three points on a VAS pain scale, although in some individual patients it may be higher. For patients with a high response to opioid use, care should be taken to assure that there is no abuse or diversion occurring. The physician and patient must agree upon defined functional goals as well as pain goals. If functional goals are not being met, the opioid trial should be reassessed. The full spectrum of side effects should be

reviewed. The shared decision making agreement signed by the patient must clarify under what term the opioids will be tapered. Refer to Subsection on the shared decision making agreement, below.

[b]. Therapeutic Trial Indications. A therapeutic trial of opioids should not be employed unless the patient has begun multi-disciplinary pain management. The trial shall last one month. If there is no functional effect, the drug should be tapered. Chronic use of opioids should not be prescribed until the following have been met:

[i].the failure of pain management alternatives, including active therapies, cognitive behavioral therapy, pain self-management techniques, and other appropriate medical techniques;

[ii].physical and psychological and/or psychiatric assessment including a full evaluation for alcohol or drug addiction, dependence or abuse, performed by two specialists with one being the authorized treating physician. The patient should be stratified as to low, medium, or high risk for abuse based on behaviors and prior history of abuse. High risk patients are those with active substance abuse of any type or a history of opioid abuse. These patients should generally not be placed on chronic opioids. If it is deemed appropriate to do so, physician addiction specialists should be monitoring the care. Moderate risk factors include a history of non-opioid substance abuse disorder, prior trauma particularly sexual abuse, tobacco use, widespread pain, poor pain coping, depression, and dysfunctional cognitions about pain and analgesic medications (see below). Pre-existing respiratory or memory problems should also be considered. Patients with a past history of substance abuse or other psychosocial risk factors should be co-managed with a physician addiction specialist;

[iii].risk factors to consider: history of severe post-operative pain, opioid analgesic tolerance (daily use for months), current mixed opioid agonist/antagonist treatment (e.g., buprenorphine, naltrexone), chronic pain (either related or unrelated to the surgical site), psychological comorbidities (e.g., depression, anxiety, catastrophizing), history of substance use disorder, history of "all over body pain", history of significant opioid sensitivities (e.g., nausea, sedation), and history of intrathecal pump use or nerve stimulator implanted for pain control;

[iv].employment requirements are outlined. The patient's employment requirements should also be discussed as well as the need to drive. It is generally not recommended to allow workers in safety sensitive positions to take opioids. Opioid naïve patients or those changing doses are likely to have decreased driving ability. Some patients on chronic opioids may have nominal interference with driving ability; however, effects are specific to individuals. Providers may choose to order certified driver rehabilitation assessment;

[v].urine drug screening for substances of abuse and substances currently prescribed. Clinicians should keep in mind that there are an increasing number of deaths

due to the toxic misuse of opioids with other medications and alcohol. Drug screening is a mandatory component of chronic opioid management. It is appropriate to screen for alcohol and marijuana use and have a contractual policy regarding both alcohol and marijuana use during chronic opioid management. Alcohol use in combination with opioids is likely to contribute to death;

[vi].review of the Prescription Monitoring Program. Louisiana Revised Statutes 40:978 and 40:1001-1014. Informed, written, witnessed consent by the patient including the aspects noted above. Patients should also be counseled on safe storage and disposal of opioids;

[vii].the trial, with a short-acting agent, should document sustained improvement of pain control, at least a 30 percent reduction, and of functional status, including return-to-work, and/or increase in activities of daily living. It is necessary to establish goals which are specific, measurable, achievable, and relevant prior to opioid trial or adjustment to measure changes in activity/function. Measurement of functional goals may include patient completed validated functional tools. Frequent follow-up at least every two to four weeks may be necessary to titrate dosage and assess clinical efficacy.

[c]. On-Going, Long-Term Management after a successful trial should include:

[i].prescriptions from a single practitioner;

[ii].ongoing review and documentation of pain relief, functional status, appropriate medication use, and side effects; full review at least every three months;

[iii].ongoing effort to gain improvement of social and physical function as a result of pain relief;

[iv].review of the Prescription Monitoring Program (PMP);

[v].shared decision making agreement detailing the following:

{a}. side effects anticipated from the medication;

{b}. requirement to continue active therapy;

{c}. need to achieve functional goals including return to work for most cases;

{d}. reasons for termination of opioid management, referral to addiction treatment, or for tapering opioids (tapering is usually for use longer than 30 days). Examples to be included in the contract include, but are not limited to:

{i}. diversion of medication;

{ii}.lack of functional effect at higher doses;

{iii}. non-compliance with other drug use;

{iv}. drug screening showing use of drugs outside of the prescribed treatment or evidence of non-compliant use of prescribed medication;

{v}.requests for prescriptions outside of the defined time frames;

{vi}. lack of adherence identified by pill count, excessive sedation, or lack of functional gains

{vii}. excessive dose escalation with no decrease in use of short-term medications;

{viii}. apparent hyperalgesia;

{ix}. shows signs of substance use disorder (including but not limited to work or family problems related to opioid use, difficulty controlling use, craving);

{x}.experiences overdose or other serious adverse event

{xi}. shows warning signs for overdose risk such as confusion, sedation, or slurred speech.

{e}. patient agreements should be written at a sixth grade reading level to accommodate the majority of patients;

{f}. use of random drug screening, initially, four times a year or possibly more with documented suspicion of abuse or diversion or for stabilization or maintenance phase of treatment. In addition to those four or more random urine drug screens, quantitative testing is appropriate in cases of inconsistent findings, suspicions, or for particular medications that patient is utilizing that is not in the qualitative testing.;

{i}. drugs or drug classes for which screening is performed should only reflect those likely to be present based on the patient's medical history or current clinical presentation, illicit substances, the practitioner's suspicion, and without duplication;

{ii}.qualitative urine drug testing (UDT) (i.e., immunoassay to evaluate, indicates the drug is present) that is utilized for pain management or substance abuse monitoring, may be considered medically necessary for: baseline screening/Induction phase before initiating treatment or at time treatment is initiated, stabilization phase of treatment with targeted weekly qualitative screening for a maximum of four weeks. (This type of monitoring is done to identify those patients who are expected to be on a stable dose of opioid medication within a four-week timeframe.) Maintenance phase of treatment with targeted qualitative screening once every one to three months. Subsequent monitoring phase of treatment at a frequency appropriate for the risk level of the individual patient. (This type of monitoring is done to identify those patients who are noncompliant or abusing prescription drugs or illicit drugs.) Note: In general, qualitative urine drug testing should not require more than four tests in a 12-month period. Additional testing, as listed above, would require clinical justification of medical necessity;

{iii}. quantitative UDT (i.e., gas chromatography and or mass spectrometry [GCMS] as confirmatory, indicates the amount of drug is present) that is utilized for pain management or substance abuse monitoring, may be considered medically necessary under the following circumstances: When immunoassays for the relevant drug(s) are not commercially available, or in specific situations when qualitative urine drug levels are required for clinical decision making. The following qualitative urine drug screen results must be present and documented: Positive for a prescription drug that is not prescribed to the patient; or Negative for a prescription drug that is prescribed to the patient; or Positive for an illicit drug;

{iv}. quantitative testing is not appropriate for every specimen and should not be done routinely. This type of test should be performed in a setting of unexpected results and not on all specimens. The rationale for each quantitative test must be supported by the ordering clinician's documentation. The record must show that an inconsistent positive finding was noted on the qualitative testing or that there was not an available qualitative test to evaluate the presence of semisynthetic or synthetic opioid, illicit drugs or other medications used for pain management in a patient. Simultaneous blood and urine drug screening or testing is not appropriate and should not be done.

{v}. urine testing, when included as one part of a structured program for pain management, has been observed to reduce abuse behaviors in patients with a history of drug misuse. Clinicians should keep in mind that there are an increasing number of deaths due to the toxic misuse of opioids with other medications and alcohol. Drug screening is a mandatory component of chronic opioid management. Clinicians should determine before drug screening how they will use knowledge of marijuana use. It is appropriate to screen for alcohol and marijuana use and have a contractual policy regarding both alcohol and marijuana use during chronic opioid management. Alcohol use in combination with opioids is likely to contribute to death. From a safety standpoint, it is more important to screen for alcohol use than marijuana use as alcohol is more likely to contribute to unintended overdose;

{vi}. physicians should recognize that occasionally patients may use non-prescribed substances because they have not obtained sufficient relief on the prescribed regime.

[vi].chronic use limited to two oral opioids;

[vii].transdermal medication use, other than buprenorphine, is generally not recommended;

[viii].use of acetaminophen-containing medications in patients with liver disease should be limited; including over-the-counter medications. Acetaminophen dose should not exceed 4 grams per day for short-term use or 2 to 3 grams/day for long-term use in healthy patients. A safer chronic dose may be 1800 mg/day;

[ix].continuing review of overall therapy plan with regard to non-opioid means of pain control and functional status;

[x].tapering of opioids may be necessary for many reasons including the development of hyperalgesia, decreased effects from an opioid, lack of compliance with the opioid contract, or intolerance of side effects. Some patients appear to experience allodynia or hyperalgesia on chronic opioids. This premise is supported by a study of normal volunteers who received opioid infusions and demonstrated an increase in secondary hyperalgesia. Options for treating hyperalgesia include withdrawing the patient from opioids and reassessing their condition. In some cases, the patient will improve when off of the opioid. In other cases, another opioid may be substituted;

{a}. Tapering may also be appropriate by patient choice, to accommodate "fit-for-duty" demands, prior to major surgery to assist with post-operative pain control, to alleviate the effects of chronic use including hypogonadism, medication side effects, or in the instance of a breach of drug agreement, overdose, other drug use aberrancies, or lack of functional benefit. It is also appropriate for any of the tapering criteria listed in Section E above.

{b}. Generally tapering can be accomplished by decreasing the dose 10 percent per week. This will generally take 6 to 12 weeks and may need to be done one drug class at a time. Behavioral support is required during this service. Tapering may occur prior to MMI or in some cases during maintenance treatment.

[xi].medication assisted treatment with buprenorphine or methadone may be considered for opioid abuse disorder, in addition to behavioral therapy;

[xii].inpatient treatment may be required for addiction or opioid tapering in complex cases. Refer to Interdisciplinary Rehabilitation Programs for detailed information on inpatient criteria;

[d].Relative Contraindications—Extreme caution should be used in prescribing controlled substances for workers with one or more "relative contraindications": Consultation with a pain or addiction specialist may be useful in these cases;

[i].history of alcohol or other substance abuse, or a history of chronic, benzodiazepine use;

[ii].sleep apnea: If patient has symptoms of sleep apnea, diagnostic tests should be pursued prior to chronic opioid use;

[iii].off work for more than six months with minimal improvement in function from other active therapy;

[iv].severe personality disorder or other known severe psychiatric disease per psychiatrist or psychologist;

[v].monitoring of behavior for signs of possible substance abuse indicating an increased risk for



addiction and possible need for consultation with an addiction specialist.

[e].High Risk Behavior: The following are high risk warning signs for possible drug abuse or addiction. Patients with these findings may need a consultation by a physician experienced in pain management and/or addiction. Behaviors in the first list are warning signs, not automatic grounds for dismissal, and should be followed up by a reevaluation with the provider.

[i].repeated behaviors in the first list may be more indicative of addiction and behaviors in the second list should be followed by a substance abuse evaluation:

{a}. First List: Less suggestive for addiction but are increased in depressed patients- Frequent requests for early refills; claiming lost or stolen prescriptions; Opioid(s) used more frequently, or at higher doses than prescribed; Using opioids to treat non-pain symptoms; Borrowing or hoarding opioids; Using alcohol or tobacco to relieve pain; Requesting more or specific opioids; Recurring emergency room visits for pain; Concerns expressed by family member(s); Unexpected drug test results; Inconsistencies in the patient's history.

{b}. Second List: More suggestive of addiction and are more prevalent in patients with substance use disorder- Buying opioids on the street; stealing or selling drugs; Multiple prescribers ("doctor shopping"); Trading sex for opioids; Using illicit drugs; Positive urine drug tests for illicit drugs; Forging prescriptions; Aggressive demands for opioids; Injecting oral/topical opioids; Signs of intoxication (ETOH odor, sedation, slurred speech, motor instability, etc.).

[ii].both daily and monthly users of nicotine were at least three times more likely to report non-medical use of opioid in the prior year. At least one study has demonstrated a prevalence of smokers and former smokers among those using opioids and at higher doses compared to the general population. It also appeared that smokers and former smokers used opioids more frequently and in higher doses than never smokers. Thus, tobacco use history may be a helpful prognosticator;

[iii].in one study, four specific behaviors appeared to identify patients at risk for current substance abuse: increasing doses on their own, feeling intoxicated, early refills, and oversedating oneself. A positive test for cocaine also appeared to be related;

[iv].one study found that half of patients receiving 90 days of continuous opioids remained on opioids several years later and that factors associated with continual use included daily opioid greater than 120 MED prior opioid exposure, and likely opioid misuse;

[v].One study suggested that those scoring at higher risk on the screener and opioid assessment for patients with pain-revised (SOAPP-R), also had greater reductions in sensory low back pain and a greater desire to take morphine. It is unclear how this should be viewed in practice.

[f].Dosing and Time to Therapeutic Effect. Oral route is the preferred route of analgesic administration because it is the most convenient and cost-effective method of administration. Transbuccal administration should be avoided other than for buprenorphine. A daily dosage above 50 MED may be appropriate for certain patients. However, when the patient's dosage exceeds 50 MED per day and/or the patient is sedentary with minimal function, consideration should be given to lowering the dosage. Some patients may require dosages above 90 MED per day. However, if the patient reaches a dosage above 90 MED per day, it is appropriate to taper or refer to a pain or addiction specialist. The provider should also adhere to all requirements in this guideline and closely monitor the patient as this is considered a high risk dosage. In some cases, buprenorphine may be a preferred medication for pain control in those patients. Consultation may be necessary.

[g].Major Side Effects—There is great individual variation in susceptibility to opioid-induced side effects and clinicians should monitor for these potential side effects. Common initial side effects include nausea, vomiting, drowsiness, unsteadiness, and confusion. Occasional side effects include dry mouth, sweating, pruritus, hallucinations, and myoclonus. Rare side effects include respiratory depression and psychological dependence. Constipation and nausea/vomiting are common problems associated with long-term opioid administration and should be anticipated, treated prophylactically, and monitored constantly. Stool softeners, laxatives, and increased dietary fluid may be prescribed. Refer to Section G.10.g, Opioid Induced Constipation. Chronic sustained release opioid use is associated with decreased testosterone in males and females and estradiol in pre-menopausal females. Patients should be asked about changes in libido, sexual function, and fatigue. Appropriate lab testing and replacement treatment should be completed.

[h].Naloxone or oral and injection Naltrexone: may be prescribed when any risk factors are present. The correct use of Naloxone and Naltrexone should be discussed with the patient and family.

[i].Benzodiazepines: should not be prescribed when opioids are used.

[j].Sedation: Driving and Other Tasks. Although some studies have shown that patients on chronic opioids do not function worse than patients not on medication, caution should be exerted, and patients should be counseled never to mix opioids with the use of alcohol or other sedating medication. When medication is increased or trials are begun, patients should not drive for at least five days. Chronic untreated pain, sedatives especially when mixed with opiates or alcohol, and disordered sleep can also impair driving abilities.

[k].Drug Interactions. Patients receiving opioid agonists should not be given a mixed agonist-antagonist such as pentazocine [Talacen, Talwin] or butorphanol [Stadol] because doing so may precipitate a withdrawal syndrome and increase pain.

[i].All sedating medication, especially benzodiazepines, should be avoided or limited to very low doses. Over-the-counter medications such as antihistamines, diphenhydramine, and prescription medications such as hydroxyzine (Anx, Atarax, Atazine, Hypam, Rezine, Vistaril) should be avoided except when being used to manage withdrawal during tapering of opioids. Alcohol should not be used.

[l].Recommended Laboratory Monitoring. Primary laboratory monitoring is recommended for acetaminophen/aspirin/ibuprofen combinations (renal and liver function, blood dyscrasias) although combination opioids are not recommended for long-term use. Morphine and other medication may require renal testing and other screening. A comprehensive genetic testing panel may be ordered by treating physician for these multiple P450 genes once in a lifetime and utilized whenever there is a question of metabolism or unusual response of any drugs used to treat pain conditions, because multiple drugs and associated genes can cause problems with opioid metabolism.

[m].Sleep Apnea Testing: Both obstructive and central sleep apnea are likely to be exaggerated by opioid use or may occur secondary to higher dose chronic opioid use and combination medication use, especially benzodiazepines and sedative hypnotics. Patients should be questioned about sleep disturbance and family members or sleeping partners questioned about loud snoring or gasping during sleep. If present, qualified sleep studies and sleep medicine consultation should be obtained. Portable sleep monitoring units are generally not acceptable for diagnosing primary central sleep apnea. Type 3 portable units with two airflow samples and an O2 saturation device may be useful for monitoring respiratory depression secondary to opioids, although there are no studies on this topic.

[n].Regular consultation of the Prescription Monitoring Program (PMP). Physicians should review their patients on the system whenever drug screens are done. This information should be used in combination with the drug screening results, functional status of the patient, and other laboratory findings to review the need for treatment and level of treatment appropriate for the patient.

[o].Addiction. If addiction occurs, patients will require treatment. Refer to Section G.12, Opioid Addiction Treatment. After detoxification, they may need long-term treatment with naltrexone (Depade, ReVia, Vivitrol), an antagonist which can be administered in a long-acting form or buprenorphine which requires specific education per the Drug Enforcement Agency (DEA).

[p]. Potentiating Agents. There is some evidence that dextromethorphan does not potentiate the effect of morphine opioids and therefore is not recommended to be used with opioids.

v. Topical Drug Delivery:

(a). Description. Topical medications, such as ketamine and capsaicin, may be an alternative treatment for neuropathic disorders and is an acceptable form of treatment

in selected patients although there is no literature addressing its use in patients with CRPS.

(b). Indications. Pain. Patient selection must be rigorous to select those patients with the highest probability of compliance.

(c). Dosing and Time to Therapeutic Effect. It is necessary that all topical agents be used with strict instructions for application as well as maximum number of applications per day to obtain the desired benefit and avoid potential toxicity.

(d). Side Effects. Localized skin reactions may occur, depending on drug.

vi. Other Agents:

(a). Agents not listed which may be useful in the treatment of CRPS and SMP include propranolol, nifedipine, calcitonin, bisphosphonates and short-term oral steroids, during the acute phase of the disease. Although propranolol, nifedipine, oral steroids, and calcitonin are used in practice, at this time there is a lack of well-designed studies to support their effectiveness compared to placebo. In individual patients, they may be effective. There is some evidence to support the use of intravenous bisphosphonate drugs, currently licensed for use in malignant bone disease and Paget's disease, in CRPS patients with abnormal bone scans. Oral use of bisphosphonates has not been studied in CRPS.

7. Orthotics/prosthetics/equipment. Devices and adaptive equipment may be necessary in order to reduce impairment and disability, to facilitate medical recovery, to avoid re-aggravation of the injury, and to maintain maximum medical improvement. Refer to the Chronic Pain Medical Treatment Guidelines for detailed information on Orthotics/Prosthetics/Equipment.

8. Patient education. Patients should be educated on their specific injury, assessment findings, and plan of treatment and encouraged to take an active role in establishing functional outcome goals. No treatment plan is complete without addressing issues of individual and/or group patient education as a means of prolonging the beneficial effects of rehabilitation, as well as facilitating self-management of symptoms and prevention of secondary disability. There is good evidence that patient education in self-management of asthma, anticoagulation, and other diseases improves appropriate use of medications, increases patient satisfaction with care, and reduces unscheduled physician visits for dealing with complications of treatment.

a. Patient education is an interactive process that provides an environment where the patient not only acquires knowledge but also gains an understanding of the application of that knowledge. Therefore, patients should be able to describe and/or will need to be educated on:

- i. The treatment plan.
- ii. Indications for and potential side effects of medications.
- iii. Their home exercise program.

- iv. Expected results of treatment.
- v. Tests to be performed, the reasons for them and their results.
- vi. Activity restrictions and return-to-work status.
- vii. Home management for exacerbations of pain.
- viii. Procedures for seeking care for exacerbations after office hours.
- ix. Home self-maintenance program.
- x. Patient responsibility to communicate with all medical providers and the employer; and
- xi. Patient responsibility to keep appointments.

b. Educational efforts should also extend to family and other support persons, the case manager, the insurer and the employer as indicated to optimize the understanding of the patient and the outcome. Professional translators should be provided for non-English speaking patients to assure optimum communication. All education, teaching, and instruction given to the patient should be documented in the medical record.

c. Effects of education weaken over time; continuing patient education sessions will be required to maximize the patient's function. The effectiveness of educational efforts can be enhanced through attention to the learning style and receptivity of the patient. Written educational materials may reinforce and prolong the impact of verbal educational efforts. Overall, patient education should emphasize health and wellness, return to work and return to a productive life.

- i. Time to produce effect: Varies with individual patient
- ii. Frequency: At each visit

9. Personality/psychological/psychiatric/ psychosocial intervention. Psychosocial treatment is generally accepted, well-established therapeutic and diagnostic procedure with selected use in acute pain problems, but with more widespread use in sub-acute and chronic pain populations. Psychosocial treatment is recommended as an important component in the total management of a patient with chronic pain and should be implemented as soon as the problem is identified.

a. Once a diagnosis consistent with the standards of the American Psychiatric Association's Diagnostic and Statistical Manual of Mental Disorders (DSM) has been determined, the patient should be evaluated for the potential need for psychiatric medications. Use of any medication to treat a diagnosed condition may be ordered by the authorized treating physician or by the consulting psychiatrist and/or medical psychologists. Visits for management of psychiatric medications are medical in nature and are not a component of psychosocial treatment. Therefore, separate visits for medication management may be necessary, depending upon the patient and medications selected.

b. The screening or diagnostic workup should have clarified and distinguished between preexisting, aggravated, and or purely causative psychological conditions. Therapeutic and diagnostic modalities include, but are not limited to, individual counseling, and group therapy. Treatment can occur within an individualized model, a multi-disciplinary model, or within a structured pain management program.

c. Refer to Chronic Pain guideline for detailed information on whom may perform the service and timeframe parameters.

10. Restriction of activities. Continuation of normal daily activities is the recommendation for chronic pain patients since immobility will negatively affect rehabilitation. Prolonged immobility results in a wide range of deleterious effects, such as a reduction in aerobic capacity and conditioning, loss of muscle strength and flexibility, increased segmental stiffness, promotion of bone demineralization, impaired disc nutrition, and the facilitation of the illness role.

a. Patients should be educated to the detrimental effects of immobility versus the efficacious use of rest periods. Adequate rest allows the patient to comply with active treatment and benefit from the rehabilitation program. In addition, complete work cessation should be avoided, if possible, since it often further aggravates the pain presentation and promotes disability. Modified return to work is almost always more efficacious and rarely contraindicated in the vast majority of injured workers with chronic pain.

11. Return-to-work is one of the major components in chronic pain management. Return to work is a subject that should be addressed by each workers' compensation provider at the first meeting with the injured employee, and be updated at each additional visit. A return to work format should be part of a company's health plan, knowing that return to work can decrease anxiety, reduce the possibility of depression, and reconnect the worker with society.

a. Because a prolonged period of time off work will decrease the likelihood of return to work, the first weeks of treatment are crucial in preventing and/or reversing chronicity and disability mindset. In complex cases, experienced nurse case managers may be required to assist in return to work. Other services, including psychological evaluation and/or treatment and vocational assistance should be employed.

b. The following should be considered when attempting to return an injured worker with chronic pain to work.

i. Job History Interview. The authorized treating physician should perform a job history interview at the time of the initial evaluation and before any plan of treatment is established. Documentation should include the workers' job demands, stressors, duties of current job, and duties of job at the time of the initial injury. In addition, cognitive and social

issues should be identified and treatment of these issues should be incorporated into the plan of care.

ii. **Coordination of Care.** Management of the case is a significant part of return to work and may be the responsibility of the authorized treating physician, occupational health nurse, risk manager, or others. Case management is a method of communication between the primary provider, referral providers, insurer, employer and employee. Because case management may be coordinated by a variety of professionals, the case manager should be identified in the medical record.

iii. **Communication** is essential between the patient, authorized treating physician, employer and insurer. Employers should be contacted to verify employment status, job duties and demands, and policies regarding injured workers. In addition, availability of temporary and permanent restrictions, for what duration, as well as other placement options should be discussed and documented.

iv. **Establishment of a Return-To-Work Status.** Return to work for persons with chronic pain should be thought of as therapeutic, assuming that work is not likely to aggravate the basic problem or increase the discomfort. In most cases of chronic pain, the worker may not be currently working or even employed. The goal of return to work would be to implement a plan of care to return the worker to any level of employment with the current employer or to return them to any type of new employment.

v. **Establishment of Activity Level Restrictions.** A formal job description for the injured/ill employee who is employed is necessary to identify physical demands at work and assist in the creation of modified duty. A jobsite evaluation may be utilized to identify tasks such as pushing, pulling, lifting, reaching above shoulder level, grasping, pinching, sitting, standing, posture, ambulatory distance and terrain, and if applicable, environment for temperature, air flow, noise and the number of hours that may be worked per day. Work restrictions assigned by the authorized treating physician may be temporary or permanent. The case manager should continue to seek out modified work until restrictions become less cumbersome or as the worker's condition improves or deteriorates.

vi. **Rehabilitation and Return to Work.** As part of rehabilitation, every attempt should be made to simulate work activities so that the authorized treating physician may promote adequate job performance. The use of ergonomic or adaptive equipment, therapeutic breaks, and interventional modalities at work may be necessary to maintain employment.

vii. **Vocational Assistance.** Formal vocational assistance is a generally accepted intervention and can assist disabled persons to return to viable employment. Assisting patients to identify vocational goals will facilitate medical recovery and aid in the maintenance of MMI by increasing motivation towards treatment and alleviating the patient's emotional distress. Chronic pain patients may benefit most if vocational assistance is provided during the interdisciplinary rehabilitation phase of treatment. To assess the patient's

vocational capacity, a vocational assessment may be utilized to identify rehabilitation program goals, as well as optimize both patient motivation and utilization of rehabilitation resources.

(a). Employers and employees of small businesses who are diagnosed with chronic pain may not be able to perform any jobs for which openings exist. Temporary employees may fill those slots while the employee functionally improves. Some small businesses hire other workers and if the injured employee returns to the job, the supervisor/owner may have an extra employee. To avoid this, it is suggested that case managers be accessed through their insurer or third party insurers. Case managers may assist with resolution of these problems, as well as assist in finding modified job tasks, or find jobs with reduced hours, etc., depending upon company philosophy and employee needs.

(b). Employers and employees of mid-sized and large businesses are encouraged by the OWCA to identify modified work within the company that may be available to injured workers with chronic pain who are returning to work with temporary or permanent restrictions. To assist with temporary or permanent placement of the injured worker, it is suggested that a program be implemented that allows the case manager to access descriptions of all jobs within the organization.

12. **Therapy — active** is based on the philosophy that therapeutic exercise and/or activity are beneficial for restoring flexibility, strength, endurance, function, range of motion, and can alleviate discomfort.

a. Active therapy requires an internal effort by the individual to complete a specific exercise or task. This form of therapy requires supervision from a therapist or medical provider such as verbal, visual and/or tactile instruction(s). Active therapy is intended to promote independence and self-reliance in managing the physical pain as well as to improve the functional status in regard to the specific diagnosis and general conditioning and well-being. At times, a provider may help stabilize the patient or guide the movement pattern but the energy required to complete the task is predominately executed by the patient.

b. Patients should be instructed to continue active therapies at home as an extension of the treatment process in order to maintain improvement levels. Home exercise can include exercise with or without mechanical assistance or resistance and functional activities with assistive devices.

c. Since CRPS and SMP patients frequently have additional myofascial pain generators, other active therapies not listed may be used in treatment. Refer to the Chronic Pain Medical Treatment Guideline for therapies and timeframe parameters not listed. The following active therapies are listed in alphabetical order:

i. **Activities of Daily Living (ADL)** Activities of daily living are instruction, active-assisted training, and/or adaptation of activities or equipment to improve a person's

capacity in normal daily activities such as self-care, work re-integration training, homemaking and driving.

(a). Time to produce effect: four to five treatments

(b). Frequency: three to five times per week

(c). Optimum duration: four to six weeks

(d). Maximum duration: six weeks

ii. Aquatic Therapy is the implementation of active therapeutic procedures (individual or group) in a swimming or therapeutic pool heated to 88-92 degrees. The water provides a buoyancy force that lessens the amount of force gravity applies to the body, and the pool should be large enough to allow full extremity range of motion and full erect posture. The decreased gravity effect allows the patient to have a mechanical advantage increases the likelihood of successful therapeutic exercise. Multiple limb involvement, weight bearing problems, and vasomotor abnormalities are frequently treated with water exercise. Indications for individuals who may not tolerate active land-based or full weight bearing therapeutic procedures or who require augmentation or other therapy. Aquatic vests, belts and other devices can be used to provide stability, balance, buoyancy, and resistance.

(a). Time to produce effect: 5 to 10 sessions

(b). Frequency: one to three times per week

(c). Optimum duration: four to six weeks

(d). Maximum duration: Six weeks. Multiple limb involvement may require longer intervention.

iii. Gait Training. Indications include the need to promote normal gait pattern with assistive devices and/or to reduce risk of fall or loss of balance. This may include instruction in safety and proper use of assistive devices and gait instruction on uneven surfaces and steps (with or without railings).

(a). Time to produce effect: one to six sessions

(b). Frequency: one to three times per week

(c). Optimum duration: two weeks. Could be needed intermittently as changes in functional status occur.

(d). Maximum duration: one month.

iv. Neuromuscular Re-education is the skilled application of exercise with manual, mechanical, or electrical facilitation to enhance strength, movement patterns, neuromuscular response, proprioception, kinesthetic sense, coordination, education of movement, balance, and posture. Indications include the need to promote neuromuscular responses through carefully timed proprioceptive stimuli, to elicit and improve motor activity in patterns similar to normal neurologically developed sequences, and improve neuromotor response with independent control.

(a). Time to produce effect: six treatments

(b). Frequency: one to three times per week

(c). Optimum duration: four to eight weeks

(d). Maximum Duration: 8 to 12 weeks

v. Stress Loading is considered a reflex and sensory integration technique involving the application of a compressive load and a carry load. It is carried out in a consistent, progressive manner and integrated as part of a home program. Use of this technique may increase symptoms initially, but symptoms generally subside with program consistency.

(a). Time to produce effect: three weeks

(b). Frequency: two to three times per week.

(c). Optimum duration: Four to six weeks and concurrent with an active daily home exercise program.

(d). Maximum Duration: 6 to 10 weeks

vi. Therapeutic exercise with or without mechanical assistance or resistance, may include isoinertial, isotonic, isometric and isokinetic types of exercises. Stress loading exercises are recommended. Indications include the need for cardiovascular fitness, reduced edema, improved muscle strength, improved connective tissue strength and integrity, increased bone density, promotion of circulation to enhance soft tissue healing, improvement of muscle recruitment, increased range of motion and are used to promote normal movement patterns. This can also include, alternative/complementary exercise movement therapy. Therapeutic exercise programs should be tissue specific to the injury and address general functional deficits as identified in the diagnosis and clinical assessment. Patients should be instructed in and receive a home exercise program that progresses as their functional status improves. Upon discharge, the patient would be independent in the performance of the home exercise program and would have been educated in the importance of continuing such a program. Educational goals would be to maintain or further improve function and to minimize the risk for aggravation of symptoms in the future.

(a). Time to produce effect: three weeks

(b). Frequency: one to three times per week

(c). Optimum duration: Four to eight weeks and concurrent with an active daily home exercise program.

(d). Maximum Duration: 8 to 12 weeks of therapist oversight. Home exercise should continue indefinitely.

13. Therapy—passive. Most of the following passive therapies and modalities are generally accepted methods of care for a variety of work-related injuries. Passive therapy includes those treatment modalities that do not require energy expenditure on the part of the patient. They are principally effective during the early phases of treatment and are directed at controlling symptoms such as pain, inflammation and swelling and to improve the rate of healing soft tissue injuries. They should be used adjunctively

with active therapies to help control swelling, pain and inflammation during the rehabilitation process. They may be used intermittently as a therapist deems appropriate, or regularly if there are specific goals with objectively measured functional improvements during treatment.

a. Factors such as exacerbation of symptoms, re-injury, interrupted continuity of care, and co-morbidities may extend durations of care. Having specific goals with objectively measured functional improvement during treatment can support extended durations of care. It is recommended that if after 6 to 8 visits no treatment effect is observed, alternative treatment interventions, further diagnostic studies or further consultations should be pursued.

b. Since CRPS and SMP patients frequently have additional myofascial pain generators, other passive therapies not listed may be used in treatment. Refer to the Chronic Pain Disorder Medical Treatment Guideline's for therapies and timeframe parameters not listed. The following passive therapies are listed in alphabetical order:

i. Continuous Passive Motion (CPM): is rarely indicated in CRPS but may occasionally be warranted if the patient shows signs of contracture despite active therapy.

(a). Time to produce effect: Four to six treatments

(b). Frequency: Varies, between two to three times per day and one time per week.

(c). Optimum duration: Four treatments

(d). Maximum duration: Six treatments. Provide home unit with improvement.

ii. Fluidotherapy. Used primarily for desensitization and to facilitate increased active range of motion. Thermal heat conduction and convection is advantageous for vasodilation, muscle relaxation, and preparation for stress and activity (exercise).

(a). Time to produce effect: Three treatments

(b). Frequency: Three times per week

(c). Optimum duration: Two months

(d). Maximum duration: Two months as a primary therapy or intermittently as an adjunct therapy to other procedures.

iii. Orthotics/Splinting. Static splinting is discouraged. Dynamic splinting may occasionally be useful in controlling proximal hypertonicity or for other concurrent pain generators.

(a). Time to produce effect: One week

(b). Frequency: varies depending upon application

(c). Optimum duration: One month

(d). Maximum duration: Two months

iv. Paraffin Bath. Indications include the need to enhance collagen extensibility before stretching, reduce muscle guarding, and to prepare for functional restoration activities.

(a). Time to produce effect: One to two treatments

(b). Frequency: One to three times per week as an adjunct treatment to other procedures. May use daily if available at home

(c). Optimum duration: Two weeks

(d). Maximum duration: Three to four weeks. If effective, purchase home unit.

v. Desensitization is accomplished through sensory integration techniques. Concurrent desensitization techniques are generally accepted as a treatment for CRPS. Home techniques using soft cloths of various textures, massage, and vibrators may be beneficial in reducing allodynia and similar sensory abnormalities.

(a). Time to produce effect: Six treatments

(b). Frequency: Three times per week and concurrent with home exercise program

(c). Optimum duration: Three weeks with reinforcement of home program

(d). Maximum duration: One month.

vi. Superficial Heat Therapy. Superficial heat is a thermal agent applied to raise the body tissue temperature. It is indicated before exercise to elevate the pain threshold, alleviate muscle spasm, and promote increased movement. Heat packs can be used at home as an extension of therapy in the clinic setting.

(a). Time to produce effect: Immediate

(b). Frequency: One to three times per week

(c). Optimum duration: Two weeks as primary or intermittently as an adjunct to other therapeutic procedures.

(d). Maximum duration: Two weeks. Home use as a primary modality may continue at the providers' discretion.

AUTHORITY NOTE: Promulgated in accordance with R.S. 23:1203.1.

HISTORICAL NOTE: Promulgated by the Louisiana Workforce Commission, Office of Workers Compensation Administration, LR 37:1723 (June 2011), amended LR 46:254 (February 2020).

**§2133. Therapeutic Procedures—Operative**

A. When considering operative intervention in chronic pain management, the treating physician must carefully consider the inherent risk and benefit of the procedure. All operative intervention should be based on a positive correlation with clinical findings, the clinical course, and diagnostic tests. A comprehensive assessment of these factors should have led to a specific diagnosis with positive identification of the pathologic condition(s).

B. Surgical procedures are seldom meant to be curative and would be employed in conjunction with other treatment modalities for maximum functional benefit. Functional benefit should be objectively measured and includes the following:

1. Return to work or maintaining work status.
2. Fewer restrictions at work or performing activities of daily living (ADL).
3. Decrease in usage of medications.
4. Measurable functional gains, such as increased range of motion or documented increase in strength.

C. Education of the patient should include the proposed goals of the surgery, expected gains, risks or complications, and alternative treatment.

1. Intrathecal drug delivery. This mode of therapy delivers small doses of medications directly into the cerebrospinal fluid. Refer to the Chronic Pain Medical Treatment Guideline's for detailed information and recommendations for its use in CRPS patients with chronic pain.

2. Neurostimulation is the delivery of low-voltage electrical stimulation to the spinal cord or peripheral nerves to inhibit or block the sensation of pain. Refer to the Chronic Pain Medical Treatment Guideline's for detailed information and recommendations for its use in CRPS patients with chronic pain.

### 3. Sympathectomy

a. Description. Destruction of part of the sympathetic nervous system, which is not generally accepted or widely used. Long-term success with this pain relief treatment is poor. This procedure requires prior authorization.

b. Indications. Single extremity CRPS-I or SMP; distal pain only (should not be done if the proximal extremity is involved). Local anesthetic Stellate Ganglion Block, Kuntz Fiber Block or Lumbar Sympathetic Block consistently gives 90 to 100 percent relief each time a technically good block is performed (with measured rise in temperature). The procedure may be considered for individuals who have limited duration of relief from blocks. Permanent neurological complications are common.

AUTHORITY NOTE: Promulgated in accordance with R.S. 23:1203.1.

HISTORICAL NOTE: Promulgated by the Louisiana Workforce Commission, Office of Workers Compensation Administration, LR 37:1733 (June 2011), amended LR 46:267 (February 2020).

## §2135. Maintenance Management

A. Successful management of chronic pain conditions results in fewer relapses requiring intense medical care. Failure to address long-term management as part of the overall treatment program may lead to higher costs and greater dependence on the health care system. Management of CRPS and SMP continues after the patient has met the

definition of maximum medical improvement (MMI). MMI is declared when a patient's condition has plateaued and the authorized treating physician believes no further medical intervention is likely to result in improved function. When the patient has reached MMI, a physician must describe in detail the maintenance treatment.

B. Maintenance care in CRPS and SMP requires a close working relationship between the carrier, the providers, and the patient. Providers and patients have an obligation to design a cost effective, medically appropriate program that is predictable and allows the carrier to set aside appropriate reserves. Carriers and adjusters have an obligation to assure that medical providers can plan medically appropriate programs. A designated primary physician for maintenance team management is recommended.

C. Maintenance Care will be based on principles of patient self-management. When developing a maintenance plan of care, the patient, physician and insurer should attempt to meet the following goals:

1. Maximal independence will be achieved through the use of home exercise programs or exercise programs requiring special facilities (e.g., pool, health club) and educational programs;
2. Modalities will emphasize self management and self-applied treatment;
3. Management of pain or injury exacerbations will emphasize initiation of active therapy techniques and may occasionally require anesthetic injection blocks.
4. Dependence on treatment provided by practitioners other than the authorized treating physician will be minimized;
5. Periodic reassessment of the patient's condition will occur as appropriate.
6. Patients will understand that failure to comply with the elements of the self-management program or therapeutic plan of care may affect consideration of other interventions.

### D. Specific Maintenance Interventions and Parameters

1. Home exercise programs and exercise equipment. Most patients have the ability to participate in a home exercise program after completion of a supervised exercise rehabilitation program. Programs should incorporate an exercise prescription including the continuation of an age-adjusted and diagnosis-specific program for aerobic conditioning, flexibility, stabilization, and strength. Some patients may benefit from the purchase or rental of equipment to maintain a home exercise program. Determination for the need of home equipment should be based on medical necessity to maintain MMI, compliance with an independent exercise program, and reasonable cost. Before the purchase or long-term rental of equipment, the patient should be able to demonstrate the proper use and effectiveness of the equipment. Effectiveness of equipment should be evaluated on its ability to improve or maintain functional areas related to activities of daily living or work activity. Occasionally, compliance evaluations may be made

through a 4-week membership at a facility offering similar equipment. Home exercise programs are most effective when done three to five times a week.

2. Exercise programs requiring special facilities. Some patients may have higher compliance with an independent exercise program at a health club versus participation in a home program. All exercise programs completed through a health club facility should focus on the same parameters of an age-adjusted and diagnosis-specific program for aerobic conditioning, flexibility, stabilization, and strength. Selection of health club facilities should be limited to those able to track attendance and utilization, and provide records available for physician and insurer review. Prior to purchasing a membership, a therapist and or exercise specialist who has treated the patient may visit the facility with the patient to assure proper use of the equipment.

a. Frequency: two to three times per week.

b. Optimal Duration: one to three months.

c. Maximum Maintenance duration: Three months. Continuation beyond three months should be based on functional benefit and patient compliance. Health club membership should not extend beyond three months if attendance drops below two times per week on a regular basis.

3. Patient education management. Educational classes, sessions, or programs may be necessary to reinforce self-management techniques. This may be performed as formal or informal programs, either group or individual.

a. Maintenance duration: Two to six educational sessions during one 12-month period.

4. Psychological management. An ideal maintenance program will emphasize management options implemented in the following order: individual self-management (pain control, relaxation and stress management, etc.), group counseling, individual counseling by a psychologist or psychiatrist and in-patient treatment. Aggravation of the injury may require more intense psychological treatment to restore the patient to baseline. In those cases, use treatments and timeframe parameters listed in the Biofeedback and Psychological Evaluation or Intervention sections.

a. Maintenance duration: 6 to 10 visits during one 12-month period.

5. Non-narcotic medication management. In some cases, self-management of pain and injury exacerbations can be handled with medications, such as those listed in Medication Section. Physicians must follow patients who are on any chronic medication or prescription regimen for efficacy and side effects. Laboratory or other testing may be appropriate to monitor medication effects on organ function.

a. Maintenance duration: Usually, four medication reviews within a 12-month period. Frequency depends on the medications prescribed. Laboratory and other monitoring as appropriate.

6. Narcotic medication management. As compared with other pain syndromes, there may be a role for chronic augmentation of the maintenance program with narcotic medications. In selected cases, scheduled medications may prove to be the most cost effective means of insuring the highest function and quality of life; however, inappropriate selection of these patients may result in a high degree of iatrogenic illness. A patient should have met the criteria in opioids section of these guidelines before beginning maintenance narcotics. Laboratory or other testing may be appropriate to monitor medication effects on organ function. The following management is suggested for maintenance narcotics:

a. The medications should be clearly linked to improvement of function, not just pain control. All follow up visits should document the patient's ability to perform routine functions satisfactorily. Examples include the abilities to: perform work tasks, drive safely, pay bills or perform basic math operations, remain alert for 10 hours, or participate in normal family and social activities. If the patient is not maintaining reasonable levels of activity the patient should usually be tapered from the narcotic and tried on a different long-acting opioid.

b. A low dose narcotic medication regimen should be defined, which may minimally increase or decrease over time. Dosages will need to be adjusted based on side effects of the medication and objective function of the patient. A patient may frequently be maintained on additional non-narcotic medications to control side effects, treat mood disorders, or control neuropathic pain; however, only one long-acting narcotic and one short-acting narcotic for rescue use should be prescribed in most cases.

c. All patients on chronic narcotic medication dosages need to sign an appropriate narcotic contract with their physician for prescribing the narcotics.

d. The patient must understand that continuation of the medication is contingent on their cooperation with the maintenance program. Use of non-prescribed drugs may result in tapering of the medication. The clinician may order random drug testing when deemed appropriate to monitor medication compliance.

e. Patients on chronic narcotic medication dosages must receive them through one prescribing physician.

i. Maintenance duration: Up to 12 visits within a 12-month period to review the narcotic plan. Laboratory and other monitoring as appropriate.

7. Therapy management. Some treatment may be helpful on a continued basis during maintenance care if the therapy maintains objective function and decreases medication use. Aggravation of the injury may require intensive treatment, including injections, PT and/or OT to get the patient back to baseline. In those cases, treatments and timeframe parameters listed in Section H, 13 and 14, Active and Passive Therapy.



a. Active Therapy, Acupuncture, and Manipulation maintenance duration: 10 visits in a 12-month period.

#### 8. Injection therapy

a. Sympathetic Blocks. These injections are considered appropriate if they maintain or increase function for a minimum of four to eight weeks. Maintenance blocks are usually combined with and enhanced by the appropriate neuropharmacological medication(s) and other care. It is anticipated that the frequency of the maintenance blocks may increase in the cold winter months or with stress.

i. Maintenance duration. Not to exceed six to eight blocks in a 12-month period for a single extremity and to be separated by no less than four-week intervals. Increased frequency may need to be considered for multiple extremity involvement or for acute recurrences of pain and symptoms. For treatment of acute exacerbations, consider 2 to 6 blocks with a short time interval between blocks.

b. Trigger Point Injections. These injections may occasionally be necessary to maintain function in those with myofascial problems.

i. Maintenance duration. Not more than four injections per session not to exceed three to six sessions per 12-month period.

9. Purchase or rental of durable medical equipment. It is recognized that some patients may require ongoing use of self-directed modalities for the purpose of maintaining function and or analgesic effect. Purchase or rental of modality based equipment should be done only if the assessment by the physician and or therapist has determined the effectiveness, compliance, and improved or maintained function by its application. It is generally felt that large expense purchases such as spas, whirlpools, and special mattresses are not necessary to maintain function beyond the areas listed above.

a. Maintenance duration: Not to exceed three months for rental equipment. Purchase if effective.

AUTHORITY NOTE: Promulgated in accordance with R.S. 23:1203.1.

HISTORICAL NOTE: Promulgated by the Louisiana Workforce Commission, Office of Workers Compensation Administration, LR 37:1734 (June 2011), amended LR 46:267 (February 2020).

## Chapter 22. Neurological and Neuromuscular Disorder Medical Treatment Guidelines

### Subchapter A. Carpal Tunnel Syndrome (CTS) Medical Treatment Guidelines

#### §2201. Introduction

A. This document has been prepared by the Louisiana Workforce Commission, Office of Workers' Compensation

(OWCA) and should be interpreted within the context of guidelines for physicians/providers treating individuals qualifying under Louisiana's Workers' Compensation Act as injured workers with CTS. Although the primary purpose of this document is advisory and educational, these guidelines are enforceable under the Louisiana Workers Compensation Act. All medical care, services, and treatment owed by the employer to the employee in accordance with the Louisiana Workers' Compensation Act shall mean care, services, and treatment in accordance with these guidelines. Medical care, services, and treatment that varies from these guidelines shall also be due by the employer when it is evidence, that a variance from these guidelines is reasonably required to cure or relieve the injured worker from the effects of the injury or occupational disease given the circumstances. Therefore, these guidelines are not relevant as evidence of a provider's legal standard of professional care. To properly utilize this document, the reader should not skip nor overlook any sections.

AUTHORITY NOTE: Promulgated in accordance with R.S. 23:1203.1.

HISTORICAL NOTE: Promulgated by the Louisiana Workforce Commission, Office of Workers Compensation Administration, LR 37:1736 (June 2011), amended LR 47:1653 (November 2021).

#### §2203. General Guideline Principles

A. The principles summarized in this section are key to the intended implementation of all Office of Workers' Compensation medical treatment guidelines and critical to the reader's application of the guidelines in this document.

1. Application of Guidelines. The OWCA provides procedures to implement medical treatment guidelines and to foster communication to resolve disputes among the provider, payer, and patient through the Office of Worker's Compensation Act.

2. Education. Education of the patient and family, as well as the employer, insurer, policy makers and the community should be the primary emphasis in the treatment of workers' compensation injuries. Currently, practitioners often think of education last, after medications, manual therapy, and surgery. Practitioners must implement strategies to educate patients, employers, insurance systems, policy makers, and the community as a whole. An education-based paradigm should always start with inexpensive communication providing reassuring and evidence-based information to the patient. More in-depth education is currently a component of treatment regimens which employ functional, restorative, preventive and rehabilitative programs. No treatment plan is complete without addressing issues of individual and/or group patient education as a means of facilitating self-management of symptoms and prevention. Facilitation through language interpretation, when necessary, is a priority and part of the medical care treatment protocol.

3. Informed Decision Making. Providers should implement informed decision making as a crucial element of a successful treatment plan. Patients, with the assistance of their health care practitioner, should identify their personal

and professional functional goals of treatment at the first visit when a workers' compensation injury allows functional improvement. Progress towards the individual's identified functional goals should be addressed by all members of the health care team at subsequent visits and throughout the established treatment plan when a chronic pain condition allows attainment of functional goals. Injured workers may not reach functional goals to return to work and therefore they will require a significantly different plan. Nurse case managers, physical therapists, and other members of the health care team play an integral role in informed decision-making and achievement of functional goals. Patient education and informed decision-making should facilitate self-management of symptoms and prevention of further injury.

4. Treatment Parameter Duration. Time frames for specific interventions commence once treatments have been initiated, not on the date of injury. Obviously, duration will be impacted by patient adherence, as well as availability of services. Clinical judgment may substantiate the need to accelerate or decelerate the time frames discussed in this document. Such deviation shall be in accordance with La. R.S. 23:1203.1.

5. Active interventions emphasizing patient responsibility, such as therapeutic exercise and/or functional treatment, are generally emphasized over passive modalities, especially as treatment progresses. Generally, passive interventions are viewed as a means to facilitate progress in an active rehabilitation program with concomitant attainment of objective functional gains.

6. Active Therapeutic Exercise Program. Exercise program goals should incorporate patient strength, endurance, flexibility, coordination, and education. This includes functional application in vocational or community settings.

7. Positive Patient Response. Positive results are defined primarily as functional gains that can be objectively measured.

a. Objective functional gains include, but are not limited to, positional tolerances, range-of-motion (ROM), strength, and endurance, activities of daily living, ability to function at work, cognition, psychological behavior, and efficiency/velocity measures that can be quantified. Subjective reports of pain and function should be considered and given relative weight when the pain has anatomic and physiologic correlation. Anatomic correlation must be based on objective findings.

8. Re-Evaluation of Treatment Every Three to Four Weeks. If a given treatment or modality is not producing positive results within three to four weeks, the treatment should be either modified or discontinued. Reconsideration of diagnosis should also occur in the event of poor response to a seemingly rational intervention.

9. Surgical Interventions. Surgery should be contemplated within the context of expected functional outcome and not purely for the purpose of pain relief. The

concept of "cure" with respect to surgical treatment by itself is generally a misnomer. All operative interventions must be based upon positive correlation of clinical findings, clinical course, and diagnostic tests. A comprehensive assimilation of these factors must lead to a specific diagnosis with positive identification of pathologic conditions.

10. Pharmacy-Louisiana Law and Regulation. All prescribing will be done in accordance with the laws of the state of Louisiana as they pertain respectively to each individual licensee, including, but not limited to: Louisiana State Board of Medical Examiners regulations governing medications used in the treatment of non-cancer-related chronic or intractable pain; Louisiana Board of Pharmacy Prescription Monitoring Program; Louisiana Department of Health and Hospitals licensing and certification standards for pain management clinics; other laws and regulations affecting the prescribing and dispensing of medications in the state of Louisiana.

11. Six Month-Time Frame. Injuries resulting in temporary total disability require maintenance treatment and may not attain return to work in six months.

12. Return to Work. Return to work is therapeutic, assuming the work is not likely to aggravate the basic problem or increase long-term pain. An injured worker's return-to-work status shall not be the sole cause to deny reasonable and medically necessary treatment under these guidelines. Two good practices are: early contact with injured workers and provide modified work positions for short-term injuries. The practitioner ~~must~~ may provide specific physical limitations and the patient should never be released to non-specific and vague descriptions such as "sedentary" or "light duty." The following physical limitations should be considered and modified as recommended: lifting, pushing, pulling, crouching, walking, using stairs, bending at the waist, awkward and/or sustained postures, tolerance for sitting or standing, hot and cold environments, data entry and other repetitive motion tasks, sustained grip, tool usage and vibration factors. Even if there is residual chronic pain, return-to-work is not necessarily contraindicated. The practitioner should understand all of the physical demands of the patient's job position before returning the patient to full duty and should request clarification of the patient's job duties. Clarification should be obtained from the employer or, if necessary, from including, but not limited to, occupational health nurse, physical therapist, occupational therapist, vocational rehabilitation specialist, or an industrial hygienist chiropractor or another professional. American Medical Association clarifies "disability" as "activity limitations and/or participation restrictions in an individual with a health condition, disorder or disease" versus "impairment" as "a significant deviation, loss, or loss of use of any body structure or body function in an individual with a health condition, disorder or disease".

13. Delayed Recovery. Within the discretion of the treating physician, strongly consider a psychological evaluation, if not previously provided, as well as initiating interdisciplinary rehabilitation treatment and vocational goal

setting, for those patients who are failing to make expected progress 6 to 12 weeks after initiation of treatment of an injury. The OWCA recognizes that 3 to 10 percent of all industrially injured patients will not recover within the timelines outlined in this document despite optimal care. Such individuals may require treatments beyond the limits discussed within this document, but such treatment requires clear documentation by the authorized treating practitioner focusing on objective functional gains afforded by further treatment and impact upon prognosis.

14. Guideline Recommendations and Inclusion of Medical Evidence. Guidelines are recommendations based on available evidence and/or consensus recommendations. When possible, guideline recommendations will note the level of evidence supporting the treatment recommendation. When interpreting medical evidence statements in the guideline, the following apply to the strength of recommendation.

Strong	Level 1 Evidence	We Recommend
Moderate	Level 2 and Level 3 Evidence	We Suggest
Weak	Level 4 Evidence	Treatment is an Option
Inconclusive	Evidence is Either Insufficient or Conflicting	

a. Consensus guidelines are generated by a professional organization that the guidelines are intended to serve. A committee of specialists and experts are selected by the organization to create an unbiased, vetted recommendation for the treatment of specific issues within the realm of their expertise. All recommendations in the guideline are considered to represent reasonable care in appropriately selected cases, regardless of the level of evidence or consensus statement attached to it. Those procedures considered inappropriate, unreasonable, or unnecessary are designated in the guideline as “not recommended.”

15. Treatment of Pre-Existing Conditions The conditions that preexisted the work injury/disease will need to be managed under two circumstances:

a. a pre-existing condition exacerbated by a work injury/disease should be treated until the patient has returned to their objectively verified prior level of functioning or Maximum Medical Improvement (MMI); and

b. a pre-existing condition not directly caused by a work injury/disease but which may prevent recovery from that injury should be treated until its objectively verified negative impact has been controlled. The focus of treatment should remain on the work injury/disease.

B. The remainder of this document should be interpreted within the parameters of these guideline principles that may lead to more optimal medical and functional outcomes for injured workers.

AUTHORITY NOTE: Promulgated in accordance with R.S. 23:1203.1.

HISTORICAL NOTE: Promulgated by the Louisiana Workforce Commission, Office of Workers Compensation Administration, LR 37:1736 (June 2011), amended by the

Louisiana Workforce Commission, Office of Workers Compensation, LR 40:1158 (June 2014), LR 47:1653 (November 2021).

**§2205. Definitions**

A. Carpal tunnel syndrome (CTS) is one of the most common mononeuropathies (a disorder involving only a single nerve). The median nerve is extremely vulnerable to compression and injury in the region of the wrist and palm. In this area, the nerve is bounded by the wrist bones and the transverse carpal ligament. The most common site of compression is at the proximal edge of the flexor retinaculum (an area near the crease of the wrist). There is often a myofascial component in the patient's presentation. This should be considered when proceeding with the diagnostic workup and therapeutic intervention.

B. Studies have repeatedly confirmed that the diagnosis cannot be made based on any single historical factor or physical examination finding. Electrodiagnostic tests may be negative in surgically confirmed cases. Conversely, electrodiagnostic testing may be positive in asymptomatic individuals. The diagnosis of CTS, therefore, remains a clinical diagnosis based on a preponderance of supportive findings.

C. Classic findings of CTS include subjective numbness or dysesthesias confined to the median nerve distribution, worsening of symptoms at night, and positive exam findings. When the diagnosis is in question, steroid injection into the carpal tunnel is a strongly supportive test if it is followed by significant relief of symptoms.

1. Please refer to other appropriate upper extremity guidelines as necessary.

AUTHORITY NOTE: Promulgated in accordance with R.S. 23:1203.1.

HISTORICAL NOTE: Promulgated by the Louisiana Workforce Commission, Office of Workers Compensation Administration, LR 37:1738 (June 2011).

**§2207. Initial Diagnostic Procedures**

A. Introduction. The two standard procedures that are to be utilized when initially evaluating a work-related carpal tunnel complaint are History Taking, and Physical Examination. History-taking and Physical Examination are generally accepted, well-established, and widely used procedures which establish the foundation/basis for and dictate all ensuing stages of diagnostic and therapeutic procedures. When findings of clinical evaluation and those of other diagnostic procedures do not complement each other, the objective clinical findings should have preference.

B. History

1. Description of symptoms should address at least the following.

a. numbness, tingling, and/or burning of the hand involving the distal median nerve distribution; however, distribution of the sensory symptoms may vary considerably between individuals. Although the classic median nerve distribution is to the palmar aspect of the thumb, the index

finger, the middle finger and radial half of the ring finger, patients may report symptoms in any or all of the fingers. The Katz Hand diagram (see Fig. 1) may be useful in documenting the distribution of symptoms; the classic pattern of carpal tunnel affects at least two of the first three digits and does not involve dorsal and palmar aspects of the hand. A probable pattern involves the palmar but not dorsal aspect of the hand (excluding digits).

b. nocturnal symptoms frequently disrupt sleep and consist of paresthesias and/or pain in the hand and/or arm.

c. pain in the wrist occurs frequently and may even occur in the forearm, elbow or shoulder. While proximal pain is not uncommon, its presence warrants evaluation for other pathology in the cervical spine, shoulder and upper extremity.

d. the “flick sign,” or shaking the symptomatic hand to relieve symptoms may be reported.

e. clumsiness of the hand or dropping objects is often reported, but may not be present early in the course.

**Figure 1. Katz Hand Diagram**

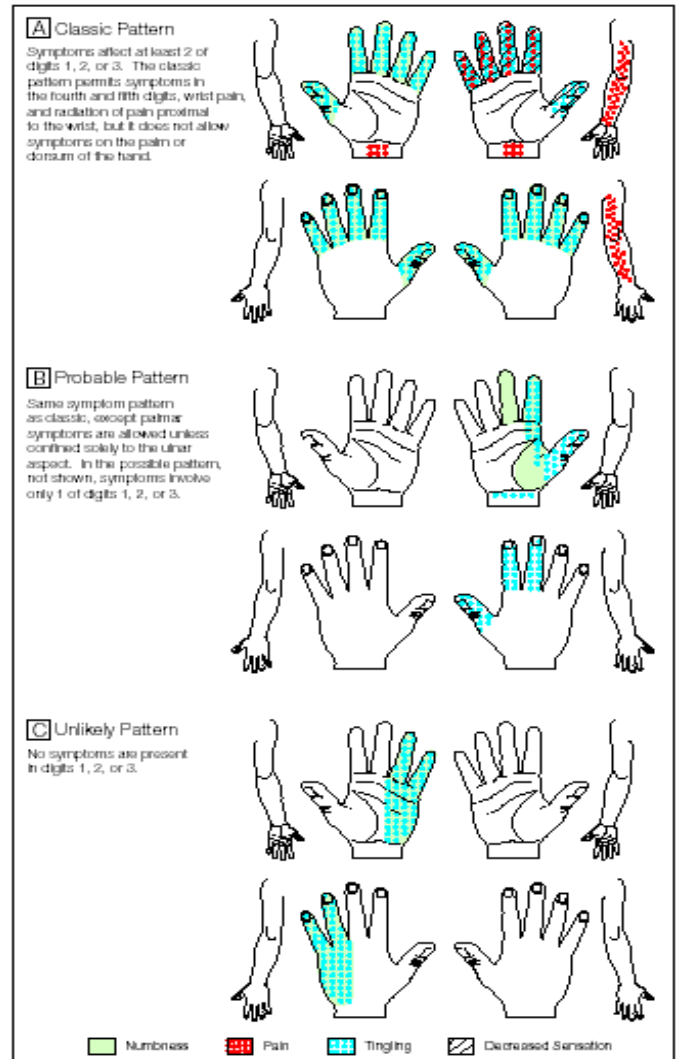

repetition, force and other risk factors, as listed in the table entitled, ‘Risk Factors Associated with CTS’- Table 2. A job site evaluation may be required.

3. Demographics. Age, hand dominance, gender, etc.

4. Past Medical History and Review of Systems. A study of CTS patients showed a 33 percent prevalence of related disease. Risk factors for CTS include female gender; obesity; Native American, Hispanic, or Black heritage, and certain medical conditions:

- a. Pregnancy
- b. Arthropathies including connective tissue disorders, rheumatoid arthritis, systemic lupus erythematosus, gout, osteoarthritis and spondyloarthropathy
- c. Colles’ fracture or other acute trauma
- d. Amyloidosis

- e. Hypothyroidism, especially in older females
- f. Diabetes mellitus, including family history or gestational diabetes
- g.. Acromegaly
- h. Use of corticosteroids or estrogens
- i. Vitamin B6 deficiency

5. Activities of Daily Living (ADLs): include such activities as self care and personal hygiene, communication, ambulation, attaining all normal living postures, travel, non-specialized hand activities, sexual function, sleep, and social and recreational activities. Specific movements in this category include pinching or grasping keys/pens/other small objects, grasping telephone receivers or cups or other similar-sized objects, and opening jars. The quality of these activities is judged by their independence, appropriateness, and effectiveness. Assess not simply the number of restricted activities but the overall degree of restriction or combination of restrictions.

6. Avocational Activities. Information must be obtained regarding sports, recreational, and other avocational activities that might contribute to or be impacted by CTD development. Activities such as hand-operated video games, crocheting/needlepoint, home computer operation, golf, racquet sports, bowling, and gardening are included in this category.

7. Social History. Exercise habits, alcohol consumption, and psychosocial factors.

C. Physical Examination . Please refer to Table 1 for respective sensitivities and specificities for findings used to diagnose CTS (a-f).

- 1. Sensory loss to pinprick, light touch, two-point discrimination or Semmes-Weinstein Monofilament tests in a median nerve distribution may occur.
- 2. Thenar atrophy may appear, but usually late in the course.
- 3. Weakness of the abductor pollicis brevis may be present.
- 4. Phalen’s sign may be positive.
- 5. Tinel’s sign over the carpal tunnel may be positive.
- 6. Closed Fist test – holding fist closed for 60 seconds reproduces median nerve paresthesia.
- 7. Evaluation of the contralateral wrist is recommended due to the frequency of bilateral involvement.

8. Evaluation of the proximal upper extremity and cervical spine for other disorders including cervical radiculopathy, thoracic outlet syndrome, other peripheral neuropathies, and other musculoskeletal disorders.

9. Signs of underlying medical disorders associated with CTS, e.g., diabetes mellitus, arthropathy, and hypothyroidism.

10. Myofascial findings requiring treatment may present in soft tissue areas near other CTD pathology, and should be documented. Refer to the Cumulative Trauma Disorder Medical Treatment Guidelines.

**Table 1: Sensitivities and Specificities and Evidence Level for Physical Examination findings**

Procedure	Sensitivity (%)	Specificity (%)	Evidence
1. Sensory testing			
Hypesthesia	15-51	85-93	Good
Katz Hand Diagram	62-89	73-88	Good
Two-point discrimination	22-33	81-100	Some
Semmes-Weinstein	52-91	59-80	Some
Vibration	20-61	71-81	None
2. Phalen’s	51-88	32-86	Some
3. Tinel’s	25-73	55-94	Some
4. Carpal tunnel compression	28-87	33-95	Some
5. Thenar atrophy	3-28	82-100	Good
Abductor pollicis brevis weakness	63-66	62-66	Good
6. Closed fist test	61	92	Some
7. Tourniquet test	16-65	36-87	None

D. Risk factors. A critical review of epidemiologic literature identified a number of physical exposures associated with CTS. For example, trauma and fractures of the hand and wrist may result in CTS. Other physical exposures considered risk factors include: repetition, force, vibration, pinching and gripping, and cold environment. When workers are exposed to several risk factors simultaneously, there is an increased likelihood of CTS. Not all risk factors have been extensively studied. Exposure to cold environment, for example, was not examined independently; however, there is good evidence that combined with other risk factors cold environment increases the likelihood of a CTS. Table 2 at the end of this section entitled, "Risk Factors Associated CTS," summarizes the results of currently available literature. No single epidemiologic study will fulfill all criteria for causality. The clinician must recognize that currently available epidemiologic data is based on population results, and that individual variability lies outside the scope of these studies. Many published studies are limited in design and methodology, and, thus, preclude conclusive results. Most studies' limitations tend to attenuate, rather than inflate, associations between workplace exposures and CTS. These guidelines are based on current epidemiologic knowledge. As with any scientific work, the guidelines are expected to change with advancing knowledge. The clinician should remain flexible and incorporate new information revealed in future studies.

**Table 2: Risk Factors Associated with Carpal Tunnel Syndrome**

<b>Diagnosis:</b> Carpal Tunnel Syndrome:	
<b>Strong evidence</b>	Combination of high exertional force (Varied from greater than 6 kg) and high repetition (work cycles less than 30 sec or greater than 50% of cycle time performing same task, length of shortest task less than 10 sec).

<b>Good evidence</b>	Repetition or force independently, use of vibration hand tools.
<b>Some evidence</b>	Wrist ulnar deviation and extension
<b>Insufficient or conflicting evidence</b>	Pinch/grip, keyboarding.

E. Laboratory tests are generally accepted, well-established, and widely used procedures. Patients should be carefully screened at the initial exam for signs or symptoms of diabetes, hypothyroidism, arthritis, and related inflammatory diseases. The presence of concurrent disease does not negate work-relatedness of any specific case. When a patient's history and physical examination suggest infection, metabolic or endocrinologic disorders, tumorous conditions, systemic musculoskeletal disorders (e.g., rheumatoid arthritis), or potential problems related to prescription of medication (e.g., renal disease and nonsteroidal anti-inflammatory medications), then laboratory tests, including, but not limited to, the following can provide useful diagnostic information:

1. Serum rheumatoid factor and Antinuclear Antigen (ANA) for rheumatoid work-up;
2. Thyroid Stimulating Hormone (TSH) for hypothyroidism;
3. Fasting glucose is recommended for obese men and women over 40 years of age, patients with a history of family diabetes, those from high-risk ethnic groups, and with a previous history of impaired glucose tolerance. A fasting blood glucose greater than 125mg/dl is diagnostic for diabetes. Urine dipstick positive for glucose is a specific but not sensitive screening test. Quantitative urine glucose is sensitive and specific in high-risk populations;
4. Serum protein electrophoresis;
5. Sedimentation rate, nonspecific, but elevated in infection, neoplastic conditions and rheumatoid arthritis;
6. Serum calcium, phosphorus, uric acid, alkaline and acid phosphatase for metabolic, endocrine and neoplastic conditions;
7. Complete Blood Count (CBC), liver and kidney function profiles for metabolic or endocrine disorders or for adverse effects of various medications;
8. Bacteriological (microorganism) work-up for wound, blood and tissue;
9. Serum B6 routine screening is not recommended due to the fact that vitamin B6 supplementation has not been proven to affect the course of carpal tunnel syndrome. However, it may be appropriate for patients on medications that interfere with the effects of vitamin B6, or for those with significant nutritional problems.
  - a. The OWCA recommends the above diagnostic procedures be considered, at least initially, the responsibility of the workers' compensation carrier to ensure that an accurate diagnosis and treatment plan can be established.

**AUTHORITY NOTE:** Promulgated in accordance with R.S. 23:1203.1.

**HISTORICAL NOTE:** Promulgated by the Louisiana Workforce Commission, Office of Workers Compensation Administration, LR 37:1738 (June 2011).

**§2209. Follow-Up Diagnostic Testing Procedures**

A. Electrodiagnostic (EDX) studies are well established and widely accepted for evaluation of patients suspected of having CTS. The results are highly sensitive and specific for the diagnosis. Studies may confirm the diagnosis or direct the examiner to alternative disorders. Studies require clinical correlation due to the occurrence of false positive and false negative results. Symptoms of CTS may occur with normal EDX studies, especially early in the clinical course. EDX findings in CTS reflect slowing of median motor and sensory conduction across the carpal tunnel region due to demyelination. Axonal loss, when present, is demonstrated by needle electromyography in median nerve-supplied thenar muscles. Findings include fibrillations, fasciculations, neurogenic recruitment and polyphasic units (reinnervation).

1. Needle electromyography of a sample of muscles innervated by the C5 to T1 spinal roots, including a thenar muscle innervated by the median nerve of the symptomatic limb, is frequently required.
2. The following EDX studies are not recommended to confirm a clinical diagnosis of CTS:
  - a. Low sensitivity and specificity compared to other EDX studies: multiple median F wave parameters, median motor nerve residual latency, and sympathetic skin response
  - b. Investigational studies: evaluation of the effect on median NCS of limb ischemia, dynamic hand exercises, and brief or sustained wrist positioning
3. To assure accurate testing, temperature should be maintained at 30-34C preferably recorded from the hand/digits. For temperature below 30C the hand should be warmed.
4. All studies must include normative values for their laboratories.
5. Positive Findings – Any of these nerve conduction study findings must be accompanied by median nerve symptoms to establish the diagnosis.
  - a. Slowing of median distal sensory and/or motor conduction through the carpal tunnel region
  - b. Electromyographic changes in the median thenar muscles in the absence of proximal abnormalities
  - c. Suggested guidelines for the upper limits of normal latencies:
    - i. Median distal motor latency (DML)-4.5msec/8cm
    - ii. Median distal sensory peak latency (DSL)-3.6msec/14cm
    - iii. Median intrapalmar peak latency (palm-wrist)-2.2msec/8cm

iv. Median-ulnar palmar sensory latency difference greater than 0.3msec

6. Because laboratories establish their own norms, a degree of variability from the suggested guideline values is acceptable.

7. In all cases, normative values are to be provided with the neurodiagnostic evaluation.

8. Suggested grading scheme by electrodiagnostic criteria for writing a consultation or report may be:

a. Mild CTS-prolonged (relative or absolute) median sensory or mixed action potential distal latency (orthodromic, antidromic, or palmar).

b. Moderate CTS-abnormal median sensory latencies as above, and prolongation (relative or absolute) of median motor distal latency.

c. Severe CTS-prolonged median motor and sensory distal latencies, with either absent or sensory or palmar potential, or low amplitude or absent thenar motor action potential. Needle examination reveals evidence of acute and chronic denervation with axonal loss.

9. Frequency of Studies/Maximum Number of Studies:

a. Indications for Initial Testing

i. patients who do not improve symptomatically or functionally with conservative measures for carpal tunnel syndrome over a three to four week period;

ii. patients in whom the diagnosis is in question;

iii. patients for whom surgery is contemplated;

iv. to rule out other nerve entrapments or a radiculopathy.

b. repeated studies may be performed:

i. to determine disease progression. 8-12 weeks is most useful when the initial studies were normal and CTS is still suspected.

ii. for inadequate improvement with non-surgical treatment for 8-12 weeks ;

iii. for persistent or recurrent symptoms following carpal tunnel release, post-op three to six months, unless an earlier evaluation is required by the surgeon.

## B. Imaging Studies

1. Radiographic Imaging. Not generally required for most CTS diagnoses. However, it may be necessary to rule out other pathology in the cervical spine, shoulder, elbow, wrist or hand. Wrist and elbow radiographs would detect degenerative joint disease, particularly scapholunate dissociation and thumb carpometacarpal abnormalities which occasionally occur with CTS.

2. Magnetic Resonance Imaging (MRI). Considered experimental and not recommended for diagnosis of Carpal Tunnel Syndrome. Trained neuroradiologists have not

identified a single MRI parameter that is highly sensitive and specific. MRI is less accurate than standard electrodiagnostic testing, and its use as a diagnostic tool is not recommended.

3. Sonography. This tool has not been sufficiently studied to define its diagnostic performance relative to electrodiagnostic studies. It is not a widely applied test. Sonography may detect synovial thickening in CTS caused by rheumatoid arthritis. It may be useful if space-occupying lesions, such as, lipomas, hemangiomas, fibromas, and ganglion cysts, are suspected. Its routine use in CTS is not recommended.

C. Adjunctive testing. Clinical indications for the use of tests and measurements are predicated on the history and systems review findings, signs observed on physical examination, and information derived from other sources and records. They are not designed to be the definitive indicator of dysfunction.

1. Electromyography. is a generally accepted, well-established procedure. It is indicated when acute and/or chronic neurogenic changes in the thenar eminence are associated with the conduction abnormalities discussed above.

2. Electroneurometer is not recommended as a diagnostic tool because it requires patient participation, cannot distinguish between proximal and distal lesions, and does not have well-validated reference values.

3. Portable Automated Electrodiagnostic. Device measures distal median nerve motor latency and F-wave latency at the wrist and has been tested in one research setting. It performed well in this setting following extensive calibration of the device. Motor nerve latency compared favorably with conventional electrodiagnostic testing, but F-wave latency added little to diagnostic accuracy. It remains an investigational instrument whose performance in a primary care setting is as yet not established, and is not recommended as a substitute for conventional electrodiagnostic testing in clinical decision-making.

4. Quantitative Sensory Testing (QST) may be used as a screening tool in clinical settings pre- and post-operatively. Results of tests and measurements of sensory integrity are integrated with the history and systems review findings and the results of other tests and measures. QST has been divided into two types of testing:

a. Threshold tests measure topognosis, the ability to exactly localize a cutaneous sensation, and pallesthesia, the ability to sense mechanical using vibration discrimination testing (quickly adapting fibers); Semmes-Wienstein monofilament testing (slowly adapting fibers);

b. Density Tests also measure topognosis and pallesthesia using static two-point discrimination (slowly adapting fibers); moving two-point discrimination (quickly adapting fibers).

5. Pinch and Grip Strength Measurements are Not generally accepted as a diagnostic tool for CTS. Strength is defined as the muscle force exerted by a muscle or group of

muscles to overcome a resistance under a specific set of circumstances. Pain, the perception of pain secondary to abnormal sensory feedback, and/or the presence of abnormal sensory feedback affecting the sensation of the power used in grip/pinch may cause a decrease in the force exerted and thereby not be a true indicator of strength. When all five handle settings of the dynamometer are used, a bell-shaped curve, reflecting maximum strength at the most comfortable handle setting, should be present. These measures provide a method for quantifying strength that can be used to follow a patient's progress and to assess response to therapy. In the absence of a bell-shaped curve, clinical reassessment is indicated.

6. Laboratory Tests. In one study of carpal tunnel patients seen by specialists, nine percent of patients were diagnosed with diabetes, seven percent with hypothyroidism, and 15 percent with chronic inflammatory disease including spondyloarthropathy, arthritis, and systemic lupus erythematosus. Up to two thirds of the patients were not aware of their concurrent disease. Estimates of the prevalence of hypothyroidism in the general population vary widely, but data collected from the Colorado Thyroid Disease Prevalence Study revealed subclinical hypothyroidism in 8.5 percent of participants not taking thyroid medication. The prevalence of chronic joint symptoms in the Behavioral Risk Factor Surveillance System (BRFSS) from the Centers for Disease Control (CDC) was 12.3 percent. If after two to three weeks, the patient is not improving the physician should strongly consider the following laboratory studies: thyroid function studies, rheumatoid screens, chemical panels, and others, if clinically indicated. Laboratory testing may be required periodically to monitor patients on chronic medications.

D. Special tests are generally well-accepted tests and are performed as part of a skilled assessment of the patients' capacity to return to work, his/her strength capacities, and physical work demand classifications and tolerance.

#### 1. Personality/Psychological/Psychiatric/ Psychosocial Evaluations.

a. These are generally accepted and well-established diagnostic procedures with selective use in the upper extremity population, but have more widespread use in subacute and chronic upper extremity populations. Diagnostic testing procedures may be useful for patients with symptoms of depression, delayed recovery, chronic pain, recurrent painful conditions, disability problems, and for preoperative evaluation. Psychological/psychosocial and measures have been shown to have predictive value for postoperative response, and therefore should be strongly considered for use pre-operatively when the surgeon has concerns about the relationship between symptoms and findings, or when the surgeon is aware of indications of psychological complication or risk factors for psychological complication (e.g. childhood psychological trauma). Psychological testing should provide differentiation between pre-existing conditions versus injury caused psychological conditions, including depression and posttraumatic stress disorder. Psychological testing should incorporate measures

that have been shown, empirically, to identify comorbidities or risk factors that are linked to poor outcome or delayed recovery;

b. Formal psychological or psychosocial evaluation should be performed on patients not making expected progress within 6 to 12 weeks following injury and whose subjective symptoms do not correlate with objective signs and test results. In addition to the customary initial exam, the evaluation of the injured worker should specifically address the following areas:

- i. employment history;
- ii. interpersonal relationships-both social and work;
- iii. patient activities;
- iv. current perception of the medical system;
- v. current perception/attitudes toward employer/job;
- vi. results of current treatment;
- vii. risk factors and psychological comorbidities that may influence outcome and that may require treatment;
- viii. childhood history, including history of childhood psychological trauma, abuse and family history of disability.

c. Personality/psychological/psychosocial evaluations consist of two components, clinical interview and psychological testing. Results should help clinicians with a better understanding of the patient in a number of ways. Thus the evaluation result will determine the need for further psychosocial interventions; and in those cases, Diagnostic and Statistical Manual of Mental Disorders (DSM) diagnosis should be determined and documented. The evaluation should also include examination of both psychological comorbidities and psychological risk factors that are empirically associated with poor outcome and/or delayed recovery. An individual with a Ph.D., Psy.D, or psychiatric M.D./D.O. credentials should perform initial evaluations, which are generally completed within one to two hours. A professional fluent in the primary language of the patient is preferred. When such a provider is not available, services of a professional language interpreter should be provided.

d. Frequency: one-time visit for the clinical interview. If psychometric testing is indicated as a part of the initial evaluation, time for such testing shall be allotted at least, six hours of professional time or whatever is deemed appropriate by the health care professional.

i. Job site evaluation is a comprehensive analysis of the physical, mental and sensory components of a specific job. These components may include, but are not limited to: postural tolerance (static and dynamic); aerobic requirements; range of motion; torque/force; lifting/carrying; cognitive demands; social interactions; visual perceptual; environmental requirements of a job; repetitiveness; and essential functions of a job. Job descriptions provided by the



employer are helpful but should not be used as a substitute for direct observation.

(a). Frequency: One time with additional visits as needed for follow-up per job site.

ii. Functional Capacity evaluation is a comprehensive or modified evaluation of the various aspects of function as they relate to the worker's ability to return to work. Areas such as endurance, lifting (dynamic and static), postural tolerance, specific range of motion, coordination and strength, worker habits, employability and financial status, as well as psychosocial aspects of competitive employment may be evaluated. Components of this evaluation may include: musculoskeletal screen; cardiovascular profile/aerobic capacity; coordination; lift/carrying analysis; job-specific activity tolerance; maximum voluntary effort; pain assessment/psychological screening; and non-material and material handling activities.

(a). Frequency: Can be used initially to determine baseline status. Additional evaluations can be performed to monitor and assess progress and aid in determining the endpoint for treatment.

iii. Vocational Assessment: The vocational assessment should provide valuable guidance in the determination of future rehabilitation program goals. It should clarify rehabilitation goals, which optimize both patient motivation and utilization of rehabilitation resources. If prognosis for return to former occupation is determined to be poor, except in the most extenuating circumstances, vocational assessment should be implemented within 3 to 12 months post-injury. Declaration of MMI should not be delayed solely due to lack of attainment of a vocational assessment.

(a). Frequency: One time with additional visits as needed for follow-up

iv. Work Tolerance Screening: is a determination of an individual's tolerance for performing a specific job as based on a job activity or task. It may include a test or procedure to specifically identify and quantify work-relevant cardiovascular, physical fitness and postural tolerance. It may also address ergonomic issues affecting the patient's return-to-work potential. May be used when a full FCE is not indicated.

(a). Frequency: One time for evaluation. May monitor improvements in strength every three to four weeks up to a total of six evaluations.

**AUTHORITY NOTE:** Promulgated in accordance with R.S. 23:1203.1.

**HISTORICAL NOTE:** Promulgated by the Louisiana Workforce Commission, Office of Workers Compensation Administration, LR 37:1740 (June 2011), LR 47:1654 (November 2021).

### **§2211. Therapeutic Procedures—Non-Operative**

A. Before initiation of any therapeutic procedure, the authorized treating provider, employer, and insurer must consider these important issues in the care of the injured worker.

B. First, patients undergoing therapeutic procedure(s) should be released or returned to modified or restricted duty during their rehabilitation at the earliest appropriate time. Refer to "Return-to-Work" in this section for detailed information.

C. Second, cessation and/or review of treatment modalities should be undertaken when no further significant subjective or objective improvement in the patient's condition is noted. If patients are not responding within the recommended duration periods, alternative treatment interventions, further diagnostic studies or consultations should be pursued.

D. Third, providers should provide and document education to the patient. No treatment plan is complete without addressing issues of individual and/or group patient education as a means of facilitating self-management of symptoms.

E. Lastly, formal psychological or psychosocial screening should be performed on patients not making expected progress within 6 to 12 weeks following injury and whose subjective symptoms do not correlate with objective signs and tests.

F. In cases where a patient is unable to attend an outpatient center, home therapy may be necessary. Home therapy may include active and passive therapeutic procedures as well as other modalities to assist in alleviating pain, swelling, and abnormal muscle tone. Home therapy is usually of short duration and continues until the patient is able to tolerate coming to an outpatient center.

G. Non-operative treatment procedures for CTS can be divided into two groups: conservative care and rehabilitation. Conservative care is treatment applied to a problem in which spontaneous improvement is expected in 90 percent of the cases within three months. It is usually provided during the tissue-healing phase and lasts no more than six months, and often considerably less. Rehabilitation is treatment applied to a more chronic and complex problem in a patient with de-conditioning and disability. It is provided during the period after tissue healing to obtain maximal medical recovery. Treatment modalities may be utilized sequentially or concomitantly depending on chronicity and complexity of the problem, and treatment plans should always be based on a diagnosis utilizing appropriate diagnostic procedures.

H. The following procedures are listed in alphabetical order.

1. Acupuncture is an accepted and widely used procedure for the relief of pain and inflammation and there is some scientific evidence to support its use. The exact mode of action is only partially understood. Western medicine studies suggest that acupuncture stimulates the nervous system at the level of the brain, promotes deep relaxation, and affects the release of neurotransmitters. Acupuncture is commonly used as an alternative or in addition to traditional Western pharmaceuticals. While it is commonly used when pain medication is reduced or not

tolerated, it may be used as an adjunct to physical rehabilitation and/or surgical intervention to hasten the return of functional activity. Acupuncture should be performed by licensed practitioners.

a. Definition: Acupuncture is the insertion and removal of filiform needles to stimulate acupoints (acupuncture points). Needles may be inserted, manipulated, and retained for a period of time. Acupuncture can be used to reduce pain, reduce inflammation, increase blood flow, increase range of motion, decrease the side effect of medication-induced nausea, promote relaxation in an anxious patient, and reduce muscle spasm. Indications include joint pain, joint stiffness, soft tissue pain and inflammation, paresthesia, post-surgical pain relief, muscle spasm, and scar tissue pain.

- i. Time to produce effect: three to six treatments
- ii. Frequency: one to three times per week
- iii. Optimum duration: one to two months
- iv. Maximum duration: 14 treatments

b. Acupuncture with Electrical Stimulation is the use of electrical current (micro- amperage or milli-amperage) on the needles at the acupuncture site. It is used to increase effectiveness of the needles by continuous stimulation of the acupoint. Physiological effects (depending on location and settings) can include endorphin release for pain relief, reduction of inflammation, increased blood circulation, analgesia through interruption of pain stimulus, and muscle relaxation. It is indicated to treat chronic pain conditions, radiating pain along a nerve pathway, muscle spasm, inflammation, scar tissue pain, and pain located in multiple sites.

- i. Time to produce effect: three to six treatments
- ii. Frequency: one to three times per week
- iii. Optimum duration: one to two months
- iv. Maximum duration: 14 treatments

c. Other Acupuncture Modalities. Acupuncture treatment is based on individual patient needs and therefore treatment may include a combination of procedures to enhance treatment effect. Other procedures may include the use of heat, soft tissue manipulation/massage, and exercise. Refer to Active Therapy and Passive Therapy for a description of these adjunctive acupuncture modalities.

- i. Time to produce effect: three to six treatments
- ii. Frequency: one to three times per week
- iii. Optimum duration: one to two months
- iv. Maximum duration: 14 treatments

(a). Any of the above acupuncture treatments may extend longer if objective functional gains can be documented or when symptomatic benefits facilitate progression in the patient's treatment program. Treatment beyond 14 treatments must be documented with respect to need and ability to facilitate positive symptomatic or

functional gains. Such care should be re-evaluated and documented with each series of treatments.

## 2. Biofeedback

a. A form of behavioral medicine that helps patients learn self-awareness and self-regulation skills for the purpose of gaining greater control of their physiology, such as muscle activity, brain waves, and measures of autonomic nervous system activity. Electronic instrumentation is used to monitor the targeted physiology and then displayed or fed back to the patient visually, auditorially or tactilely, with coaching by a biofeedback specialist. Biofeedback is provided by clinicians certified in biofeedback and/or who have documented specialized education, advanced training, or direct or supervised experience qualifying them to provide the specialized treatment needed (e.g., surface EMG, EEG, or other).

b. Treatment is individualized to the patient's work-related diagnosis and needs. Home practice of skills is required for mastery and may be facilitated by the use of home training tapes. The ultimate goal in biofeedback treatment is normalizing the physiology to the pre-injury status to the extent possible and involves transfer of learned skills to the workplace and daily life. Candidates for biofeedback therapy or training must be motivated to learn and practice biofeedback and self-regulation techniques.

c. Indications for biofeedback include individuals who are suffering from musculoskeletal injury where muscle dysfunction or other physiological indicators of excessive or prolonged stress response affects and/or delays recovery. Other applications include training to improve self-management of emotional stress/pain responses such as anxiety, depression, anger, sleep disturbance, and other central and autonomic nervous system imbalances. Biofeedback is often utilized along with other treatment modalities.

- i. Time to produce effect: three to four sessions
- ii. Frequency: one to two times per week
- iii. Optimum duration: five to six sessions
- iv. Maximum duration: 10 to 12 sessions.

Treatment beyond 12 sessions must be documented with respect to need, expectation, and ability to facilitate positive symptomatic or functional gains.

## 3. Injections-Therapeutic.

a. Steroids Injections. Beneficial effects of injections are well-established, but generally considered to be temporary. Recurrence of symptoms is frequent. It is not clear whether or not injections slow progression of electrodiagnostic changes. Therefore, although symptoms may be temporarily improved, nerve damage may be progressing. When motor changes are present, surgery is preferred over injections. Injections may be given for confirmation of Carpal Tunnel Syndrome Diagnosis.

- i. Time to produce effect: two to five days
- ii. Frequency: every six to eight weeks

- iii. Optimum number: two injections
- iv. Maximum number: three injections in 6 months

b. If following the first injection, symptomatic relief is followed by recurrent symptoms, the decision to perform a second injection must be weighed against alternative treatments such as surgery. Surgery may give more definitive relief of symptoms.

4. Job Site Alteration. Early evaluation and training of body mechanics and other ergonomic factors are essential for every injured worker and should be done by a qualified individual. In some cases, this requires a job site evaluation. Some evidence supports alteration of the job site in the early treatment of Carpal Tunnel Syndrome (CTS). There is no single factor or combination of factors that is proven to prevent or ameliorate CTS, but a combination of ergonomic and psychosocial factors is generally considered to be important. Physical factors that may be considered include use of force, repetition, awkward positions, upper extremity vibration, cold environment, and contact pressure on the carpal tunnel. Psychosocial factors to be considered include pacing, degree of control over job duties, perception of job stress, and supervisory support. The job analysis and modification should include input from the employee, employer, and ergonomist or other professional familiar with work place evaluation. The employee must be observed performing all job functions in order for the job site analysis to be valid. Periodic follow-up is recommended to evaluate effectiveness of the intervention and need for additional ergonomic changes.

a. Ergonomic changes should be made to modify the hazards identified. In addition workers should be counseled to vary tasks throughout the day whenever possible. Occupational Safety and Health Administration (OSHA) suggests that workers who perform repetitive tasks, including keyboarding, take 15-30 second breaks every 10 to 20 minutes, or 5-minute breaks every hour. Mini breaks should include stretching exercises.

b. Interventions should consider engineering controls, e.g., mechanizing the task, changing the tool used, or adjusting the work site, or administrative controls, e.g., adjusting the time an individual performs the task.

c. Seating Description. The following description may aid in evaluating seated work positions: The head should incline only slightly forward, and if a monitor is used, there should be 18-24 inches of viewing distance with no glare. Arms should rest naturally, with forearms parallel to the floor, elbows at the sides, and wrists straight or minimally extended. The back must be properly supported by a chair, which allows change in position and backrest adjustment. There must be good knee and legroom, with the feet resting comfortably on the floor or footrest. Tools should be within easy reach, and twisting or bending should be avoided.

d. Job Hazard Checklist. The following Table 3 is adopted from Washington State's job hazard checklist, and

may be used as a generally accepted guide for identifying job duties which may pose ergonomic hazards. The fact that an ergonomic hazard exists at a specific job, or is suggested in the table, does not establish a causal relationship between the job and the individual with a musculoskeletal injury. However, when an individual has a work-related injury and ergonomic hazards exist that affect the injury, appropriate job modifications should be made. Proper correction of hazards may prevent future injuries to others, as well as aid in the recovery of the injured worker.

**Table 3: Identifying Job Duties Which May Pose Ergonomic Hazards**

Type of Job Duty	Hours per Day
Pinching an unsupported object(s) weighing 2 lbs or more per hand, or pinching with a force of 4 lbs or more per hand (comparable to pinching a half a ream of paper): Highly repetitive motion Palmar flexion greater than 30 degrees, dorsiflexion greater than 45 degrees, or radial deviation greater than 30 degrees ----- No other risk factors	More than 3 hours total/day ----- More than 4 hours total/day
Gripping an unsupported object(s) weighing 10 lbs or more/hand, or gripping with a force of 10 lbs or more/hand (comparable to clamping light duty automotive jumper cables onto a battery): *Handles should be rounded and soft, with at least 1-2.5" in diameter grips at least 5" long. Highly repetitive motion Palmar flexion greater than 30 degrees, dorsiflexion greater than 45 degrees, or radial deviation greater than 30 degrees ----- No other risk factors	More than 3 hours total/day ----- More than 4 hours total/day
Repetitive Motion (using the same motion with little or no variation every few seconds), excluding keying activities: High, forceful exertions with the hands, with palmar flexion greater than 30 degrees, dorsiflexion greater than 45 degrees, or radial deviation greater than 30 degrees ----- No other risk factors	More than 2 hours total/day ----- More than 6 hours total/day
Intensive Keying: Palmar flexion greater than 30 degrees, dorsiflexion greater than 45 degrees, or radial deviation greater than 30 degrees ----- No other risk factors	More than 4 hours total/day ----- More than 7 hours total/day
Repeated Impact: Using the hand (heel/base of palm) as a hammer more than once/minute	More than 2 hours total/day
Vibration: Two determinants of the tolerability of segmental vibration of the hand are the frequency and the acceleration of the motion of the vibrating tool, with lower frequencies being more poorly tolerated at a given level of imposed acceleration, expressed below in multiples of the acceleration due to gravity (10m/sec/sec). Frequency range 8-15 Hz and acceleration 6 g Frequency range 80 Hz and acceleration 40 g Frequency range 250 Hz and acceleration 250 g ----- Frequency range 8-15 Hz and acceleration 1.5 g Frequency range 80 Hz and acceleration 6 g Frequency range 250 Hz and acceleration 20 g	More than 30 minutes at a time ----- More than 4 hours at a time

5. Medications including nonsteroidal anti-inflammatory medications (NSAIDS), oral steroids, diuretics, and pyridoxine (Vitamin B6) have not been shown to have significant long-term beneficial effect in treating Carpal Tunnel Syndrome. Although NSAIDS are not curative, they and other analgesics may provide symptomatic relief. All narcotics and habituating medications should be prescribed with strict time, quantity, and duration guidelines with a definite cessation parameter. Prescribing these drugs on an as needed basis (PRN) should almost always be avoided.

a. Vitamin B6: Randomized trials have demonstrated conflicting results. Higher doses may result in development of a toxic peripheral neuropathy. In the absence of definitive literature showing a beneficial effect, use of Vitamin B6 cannot be recommended.

b. Oral Steroids: have been shown to have short-term symptomatic benefit but no long-term functional benefit and are not recommended due to possible side effects.

#### 6. Occupational Rehabilitation Programs

a. Non-Interdisciplinary. These programs are work-related, outcome-focused, individualized treatment programs. Objectives of the program include, but are not limited to, improvement of cardiopulmonary and neuromusculoskeletal functions (strength, endurance, movement, flexibility, stability, and motor control functions), patient education, and symptom relief. The goal is for patients to gain full or optimal function and return to work. The service may include the time-limited use of passive modalities with progression to achieve treatment and/or simulated/real work.

i. Work Conditioning. These programs are usually initiated once reconditioning has been completed but may be offered at any time throughout the recovery phase. It should be initiated when imminent return of a patient to modified or full duty is not an option, but the prognosis for returning the patient to work at completion of the program is at least fair to good.

(a). Length of visit: one to two hours per day

(b). Frequency: two to five visits per week

(c). Optimum duration: two to four weeks

(d). Maximum duration: six weeks. Participation in a program beyond six weeks must be documented with respect to need and the ability to facilitate positive symptomatic or functional gains.

ii. Work Simulation is a program where an individual completes specific work-related tasks for a particular job and return to work. Use of this program is appropriate when modified duty can only be partially accommodated in the work place, when modified duty in the work place is unavailable, or when the patient requires more structured supervision. The need for work place simulation should be based upon the results of a Functional Capacity Evaluation and or Job site Analysis.

(a). Length of visit: two to six hours per day

(b). Frequency: two to five visits per week

(c). Optimum duration: two to four weeks

(d). Maximum duration: six weeks. Participation in a program beyond six weeks must be documented with respect to need and the ability to facilitate positive symptomatic or functional gains.

b. Interdisciplinary programs are characterized by a variety of disciplines that participate in the assessment, planning, and/or implementation of an injured workers program with the goal for patients to gain full or optimal function and return to work. There should be close interaction and integration among the disciplines to ensure that all members of the team interact to achieve team goals. These programs are for patients with greater levels of perceived disability, dysfunction, de-conditioning and psychological involvement. For patients with chronic pain, refer to the Chronic Pain Disorder Medical Treatment Guideline.

i. Work Hardening is an interdisciplinary program addressing a patient's employability and return to work. It includes a progressive increase in the number of hours per day that a patient completes work simulation tasks until the patient can tolerate a full workday. This is accomplished by addressing the medical, psychological, behavioral, physical, functional, and vocational components of employability and return-to-work.

ii. This can include a highly structured program involving a team approach or can involve any of the components thereof. The interdisciplinary team should, at a minimum, be comprised of a qualified medical director who is board certified with documented training in occupational rehabilitation, team physicians having experience in occupational rehabilitation, occupational therapy, physical therapy, case manager, and psychologist. As appropriate, the team may also include: chiropractor, RN, or vocational specialist.

(a). Length of visit: Up to eight hours/day

(b). Frequency: two to five visits per week

(c). Optimum duration: two to four weeks

(d). Maximum duration: six weeks. Participation in a program beyond six weeks must be documented with respect to need and the ability to facilitate positive symptomatic or functional gains.

7. Orthotics/Immobilization with Splinting is a generally accepted, well-established and widely used therapeutic procedure. There is some evidence that splinting leads to more improvement in symptoms and hand function than watchful waiting alone. Because of limited patient compliance with day and night splinting in published studies, evidence of effectiveness is limited to nocturnal splinting alone. Splints should be loose and soft enough to maintain comfort while supporting the wrist in a relatively neutral position. This can be accomplished using a soft or

rigid splint with a metal or plastic support. Splint comfort is critical and may affect compliance. Although off-the-shelf splints are usually sufficient, custom thermoplastic splints may provide better fit for certain patients.

a. Splints may be effective when worn at night or during portions of the day, depending on activities. Most studies show that full time night splinting for a total of four to six weeks is the most effective protocol. Depending on job activities, intermittent daytime splinting can also be helpful. Splint use is rarely mandatory. Providers should be aware that over-usage is counterproductive, and should counsel patients to minimize daytime splint use in order to avoid detrimental effects such as stiffness and dependency over time.

b. Splinting is generally effective for milder cases of CTS. Long-term benefit has not been established. An effect should be seen in two-four weeks.

i. Time to produce effect: one-four weeks. If, after four weeks, the patient has partial improvement, continue to follow since neuropathy may worsen, even in the face of diminished symptoms.

ii. Frequency: Nightly. Daytime intermittent, depending on symptoms and activities

iii. Optimum duration: four to eight weeks

iv. Maximum duration: two to four months. If symptoms persist, consideration should be given to either repeating electrodiagnostic studies or to more aggressive treatment.

## 8. Patient Education

a. No treatment plan is complete without addressing issues of individual and/or group patient education as a means of prolonging the beneficial effects of treatment, as well as facilitating self-management of symptoms and injury prevention. The patient should be encouraged to take an active role in the establishment of functional outcome goals. They should be educated on their specific injury, assessment findings, and plan of treatment. Instruction on proper body mechanics and posture, positions to avoid, self-care for exacerbation of symptoms, and home exercise should also be addressed.

i. Time to produce effect: Varies with individual patient

ii. Frequency: Should occur at every visit

## 9. Personality/Psychological/Psychiatric/

Psychosocial Intervention is generally accepted, widely used and well established. This group of therapeutic and diagnostic modalities includes, but is not limited to, individual counseling, group therapy, stress management, psychosocial crises intervention, hypnosis and meditation. Any screening or diagnostic workup should clarify and distinguish between preexisting versus aggravated versus purely causative psychological conditions. Psychosocial intervention is recommended as an important component in the total management program that should be implemented

as soon as the problem is identified. This can be used alone or in conjunction with other treatment modalities. Providers treating patients with chronic pain should refer to the Chronic Pain Disorder Medical Treatment Guidelines.

a. Time to produce effect: two to four weeks

b. Frequency: one to three times weekly for the first 4 weeks (excluding hospitalization, if required), decreasing to one to two times per week for the second month. Thereafter, two to four times monthly.

c. Optimum duration: six weeks to three months

d. Maximum duration: 3 to 12 months. Counseling is not intended to delay but to enhance functional recovery. For select patients, longer supervised treatment may be required and if further counseling beyond 3 months is indicated, documentation addressing which pertinent issues are pre-existing versus aggravated versus causative, as well as projecting a realistic functional prognosis, should be provided by the authorized treating provider every 4 to 6 weeks during treatment.

10. Restriction of Activities. Continuation of normal daily activities is the recommendation for acute and chronic pain without neurologic symptoms. There is good evidence against the use of bed rest in cases without neurologic symptoms. Bed rest may lead to de-conditioning and impair rehabilitation. Complete work cessation should be avoided, if possible, since it often further aggravates the pain presentation. Modified return-to-work is almost always more efficacious and rarely contraindicated in the vast majority of injured workers with Carpal Tunnel Syndrome

a. Medication use in the treatment of Carpal Tunnel Syndrome is appropriate for controlling acute and chronic pain and inflammation. Use of medications will vary widely due to the spectrum of injuries from simple strains to post-surgical healing. All drugs should be used according to patient needs. A thorough medication history, including use of alternative and over the counter medications, should be performed at the time of the initial visit and updated periodically.

11. Return to Work. Early return-to-work should be a prime goal in treating Carpal Tunnel Syndrome given the poor prognosis for the injured employee who is out of work for more than six months. The employee and employer should be educated in the benefits of early return-to-work. When attempting to return an employee with CTS to the workplace, clear, objective physical restrictions that apply to both work and non-work related activities should be specified by the provider. Good communication between the provider, employee, and employer is essential. Return-to-work is any work or duty that the employee can safely perform, which may not be the worker's regular job activities. Due to the large variety of jobs and the spectrum of severity of CTS, it is not possible for the OWCA to make specific return-to-work guidelines, but the following general approach is recommended:

a. Establishment of Return-To-Work. Ascertainment of return-to-work status is part of the medical treatment and

rehabilitation plan, and should be addressed at every visit. Limitations in ADLs should also be reviewed at every encounter, and help to provide the basis for work restrictions provided they are consistent with objective findings. The OWCA recognizes that employers vary in their ability to accommodate restricted duty, but encourages employers to be active participants and advocates for early return-to-work. In most cases, the patient can be returned to work in some capacity, either at a modified job or alternate position, immediately unless there are extenuating circumstances, which should be thoroughly documented and communicated to the employer. Return-to-work status should be periodically reevaluated, at intervals generally not to exceed three weeks, and should show steady progression towards full activities and full duty.

b. Establishment of Activity Level Restrictions: It is the responsibility of the physician/provider to provide both the employee and employer clear, concise, and specific restrictions that apply to both work and non-work related activities. The employer is responsible to determine whether modified duty can be provided within the medically determined restrictions. Refer to the "Job Site Alteration" section for specific activity and ergonomic factors to be considered when establishing work restrictions for an employee with CTS.

c. Compliance with Activity Level Restrictions: The employee's compliance with the activity level restrictions is an important part of the treatment plan and should be reviewed at each visit. In some cases, a job site analysis, a functional capacity evaluation, or other special testing may be required to facilitate return-to-work and document compliance. Refer to the "Job Site Alteration" and "Work Tolerance Screening" sections.

## 12. Therapy - Active.

a. Active therapies are based on the philosophy that therapeutic exercises and/or activities are beneficial for restoring flexibility, strength, endurance, function, range of motion, and alleviating discomfort. Active therapy requires an internal effort by the individual to complete a specific exercise or task, and thus assists in developing skills promoting independence to allow self-care to continue after discharge. This form of therapy requires supervision from a therapist or medical provider such as verbal, visual, and/or tactile instructions(s). At times a provider may help stabilize the patient or guide the movement pattern, but the energy required to complete the task is predominately executed by the patient.

b. Patients should be instructed to continue active therapies at home as an extension of the treatment process in order to maintain improvement levels. Home exercise can include exercise with or without mechanical assistance or resistance and functional activities with assistance devices.

c. Interventions are selected based on the complexity of the presenting dysfunction with ongoing examination, evaluation and modification of the plan of care as improvement or lack thereof occurs. Change and/or discontinuation of an intervention should occur if there is

attainment of expected goals/outcome, lack of progress, lack of tolerance and/or lack of motivation. Passive interventions/modalities may only be used as adjuncts to the active program.

i. Nerve Gliding exercises consist of a series of flexion and extension movements of the hand and wrist that produce tension and longitudinal movement along the length of the median and other nerves of the upper extremity. These exercises are based on the principle that the tissues of the peripheral nervous system are designed for movement, and that tension and glide (excursion) of nerves may have an effect on neurophysiology through alterations in vascular and axoplasmic flow. Biomechanical principles have been more thoroughly studied than clinical outcomes. Randomized trials have been lacking or have suffered from design flaws that preclude sound conclusions of the effectiveness of these exercises, but these flaws have tended to underestimate rather than overestimate the usefulness of nerve gliding. The exercises are simple to perform and can be done by the patient after brief instruction. It is considered accepted therapy for CTS.

(a). Time to Produce Effect: two-four weeks

(b). Frequency: Up to five times per day by patient (patient-initiated)

(c). Optimum Duration: two sessions

(d). Maximum Duration: three sessions

ii. Instruction in Therapeutic Exercise. Instruction should focus on alleviating associated myofascial symptoms. Please refer to the Cumulative Trauma Disorder (CTD) guideline for information on therapeutic exercise techniques.

iii. Proper Work Techniques. Please refer to the "Job Site Evaluation" and "Job Site Alteration" sections of this guideline.

13. Therapy-Passive. Therapy includes those treatment modalities that do not require energy expenditure on the part of the patient. They are principally effective during the early phases of treatment and are directed at controlling symptoms such as pain, inflammation and swelling and to improve the rate of healing soft tissue injuries. They should be used in adjunct with active therapies. They may be used intermittently as a therapist deems appropriate or regularly if there are specific goals with objectively measured functional improvements during treatment. Diathermies have not been shown to be beneficial to patients with CTS and may interfere with nerve conduction.

a. Manual Therapy Techniques are passive interventions in which the providers use his or her hands to administer skilled movements designed to modulate pain; increase joint range of motion; reduce/eliminate soft tissue swelling, inflammation, or restriction; induce relaxation; and improve contractile and non-contractile tissue extensibility. These techniques are applied only after a thorough examination is performed to identify those for whom manual therapy would be contraindicated or for whom manual therapy must be applied with caution. Soft tissue

mobilization/manipulation techniques are generally accepted and widely used adjunctive treatment modalities in the treatment of myofascial symptoms related to carpal tunnel syndrome. Mobilization and manipulation can include myofascial release therapy, muscle energy techniques, neural gliding, high velocity, low amplitude (HVLA) technique, osteopathic manipulation, joint mobilization and non-force techniques.

- i. Time to produce effect: two to six treatments
- ii. Frequency: one-to three times/week, decreasing over time
- iii. Optimum duration: four to six weeks
- iv. Maximum duration: eight to ten weeks

b. Ultrasound: There is some evidence that ultrasound may be effective in symptom relief and in improving nerve conduction in mild to moderate cases of CTS. No studies have demonstrated long-term functional benefit. It may be used in conjunction with an active therapy program for non-surgical patients who do not improve with splinting and activity modification. It is not known if there are any long-term deleterious neurological effects from ultrasound.

c. Microcurrent TENS: There is some evidence that concurrent application of microamperage TENS applied to distinct acupuncture points and low-level laser treatment may be useful in treatment of mild to moderate CTS. This treatment may be useful for patients not responding to initial conservative treatment or who wish to avoid surgery. Patient selection criteria should include absence of denervation on EMG and motor latencies not exceeding 7 ms. The effects of microamperage TENS and low-level laser have not been differentiated; there is no evidence to suggest whether only one component is effective or the combination of both is required.

- i. Time to produce effect: one week
- ii. Frequency: three sessions per week
- iii. Optimum duration: three weeks
- iv. Maximum duration: four weeks
- v. Other Passive Therapy: For associated myofascial symptoms, please refer to the Cumulative Trauma Disorder guideline.

14. Vocational Rehabilitation is a generally accepted intervention. Initiation of vocational rehabilitation requires adequate evaluation of patients for quantification highest functional level, motivation, and achievement of maximum medical improvement. Vocational rehabilitation may be as simple as returning to the original job or as complicated as being retrained for a new occupation. It may also be beneficial for full vocational rehabilitation to be started before MMI if it is evident that the injured worker will be unable to return to his/her previous occupation. A positive goal and direction may aid the patient in decreasing stress and depression and promote optimum rehabilitation.

**AUTHORITY NOTE:** Promulgated in accordance with R.S. 23:1203.1.

**HISTORICAL NOTE:** Promulgated by the Louisiana Workforce Commission, Office of Workers Compensation Administration, LR 37:1743 (June 2011), amended LR 47:1655 (November 2021).

**§2213. Therapeutic Procedures—Operative**

A. Surgical Decompression is well-established, generally accepted, and widely used and includes open and endoscopic techniques. There is good evidence that surgery is more effective than splinting in producing long-term symptom relief and normalization of median nerve conduction velocity.

1. Endoscopic and open techniques can be used based on the experience and discretion of the surgeon.

2. Indications for Surgery include positive history, abnormal electrodiagnostic studies, and/or failure of conservative management. Job modification should be considered prior to surgery. Please refer to the “Job Site Alteration” section for additional information on job modification.

3. Surgery as an Initial Therapy. Surgery should be considered as an initial therapy in situations where:

- a. Median nerve trauma has occurred; “acute carpal tunnel syndrome”, or
- b. Electrodiagnostic evidence of moderate to severe neuropathy. EMG findings showing evidence of acute or chronic motor denervation suggest the possibility that irreversible damage may be occurring.

4. Surgery may be considered in cases where electrodiagnostic testing is normal. A second opinion from a hand surgeon is strongly recommended. The following criteria should be considered in deciding whether to proceed with surgery:

- a. the patient experiences significant temporary relief following steroid injection into the carpal tunnel; or
- b. the patient has failed 3 to 6 months of conservative treatment including work site change; and
- c. psychosocial factors have been addressed through psychological screening requirements as defined “Adjunctive Testing” in this Section; and
- d. the patient's signs and symptoms are specific for carpal tunnel syndrome

5. Suggested parameters for return-to-work are:

Time Frame	Activity Level
2 Days	Return to Work with Restrictions on utilizing the affected extremity
2-3 Weeks	Sedentary and non-repetitive work
4-6 Weeks	Case-by-case basis
6-12 Weeks	Heavy Labor, forceful and repetitive

NOTE: All return-to-work decisions are based upon clinical outcome.

B. Neurolysis has not been proven advantageous for carpal tunnel syndrome. Internal neurolysis should never be done. Very few indications exist for external neurolysis.

C. Tenosynovectomy has not proven to be of benefit in carpal tunnel syndrome.

D. Consideration for Repeat Surgery

1. The single most important factor in predicting symptomatic improvement following carpal tunnel release is the severity of preoperative neuropathy. Patients with moderate electrodiagnostic abnormalities have better results than those with either very severe or no abnormalities. Incomplete cutting of the transverse carpal ligament or iatrogenic injury to the median nerve are rare. If median nerve symptoms do not improve following initial surgery or symptoms improve initially and then recur, but are unresponsive to non-operative therapy (see Therapeutic Procedures, Non-Operative) consider the following:

- a. Recurrent synovitis;
- b. Repetitive work activities may be causing “dynamic” CTS;
- c. Scarring;
- d. Work-up of systemic diseases

2. A second opinion by a hand surgeon or qualified surgeon in treating peripheral nerve disorders is required if repeat surgery is contemplated. The decision to undertake repeat surgery must factor in all of the above possibilities. Results of surgery for recurrent carpal tunnel syndrome vary widely depending on the etiology of recurrent symptoms.

E. Post-Operative Treatment.

1. Considerations for post-operative therapy are:

a. Immobilization: There is some evidence showing that immediate mobilization of the wrist following surgery is associated with less scar pain and faster return to work. Final decisions regarding the need for splinting post-operatively should be left to the discretion of the treating physician based upon his/her understanding of the surgical technique used and the specific conditions of the patient.

b. Home Program: It is generally accepted that all patients should receive a home therapy protocol involving stretching, ROM, scar care, and resistive exercises. Patients should be encouraged to use the hand as much as possible for daily activities, allowing pain to guide their activities.

c. Supervised Therapy Program: may be helpful in patients who do not show functional improvements post-operatively or in patients with heavy or repetitive job activities. The therapy program may include some of the generally accepted elements of soft tissue healing and return to function:

i. Soft tissue healing/remodeling: May be used after the incision has healed. It may include all of the following: evaluation, whirlpool, electrical stimulation, soft tissue mobilization, scar compression pad, heat/cold application, splinting or edema control may be used as

indicated. Following wound healing, ultrasound and iontophoresis with Sodium Chloride (NaCl) may be considered for soft tissue remodeling. Diathermy is a non-acceptable adjunct.

ii. Return to function: Range of motion, therapeutic exercises and stretching exercises, strengthening, activity of daily living adaptations, joint protection instruction, posture/body mechanics education; worksite modifications may be indicated.

- (a). Time to produce effect: two- to four weeks
- (b). Frequency: two- to three times/week
- (c). Optimum duration: four- to six weeks
- (d). Maximum duration: eight weeks

AUTHORITY NOTE: Promulgated in accordance with R.S. 23:1203.1.

HISTORICAL NOTE: Promulgated by the Louisiana Workforce Commission, Office of Workers Compensation Administration, LR 37:1748 (June 2011), LR 47:1655 (November 2021).

## Subchapter B. Thoracic Outlet Syndrome

### §2215. Introduction

A. This document has been prepared by the Louisiana Workforce Commission, Office of Workers’ Compensation (OWCA) and should be interpreted within the context of guidelines for physicians/providers treating individuals qualifying under Louisiana’s Workers’ Compensation Act as injured workers with upper extremity involvement. Although the primary purpose of this document is advisory and educational, these guidelines are enforceable under the Louisiana Workers Compensation Act. All medical care, services, and treatment owed by the employer to the employee in accordance with the Louisiana Workers’ Compensation Act shall mean care, services, and treatment in accordance with these guidelines. Medical Care, services, and treatment that varies from these guidelines shall also be due by the employer when it is demonstrated to the medical director of the office by a preponderance of the scientific medical evidence, that a variance from these guidelines is reasonably required to cure or relieve the injured worker from the effects of the injury or occupational disease given the circumstances. Therefore, these guidelines are not relevant as evidence of a provider’s legal standard of professional care. To properly utilize this document, the reader should not skip nor overlook any sections.

AUTHORITY NOTE: Promulgated in accordance with R.S. 23:1203.1.

HISTORICAL NOTE: Promulgated by the Louisiana Workforce Commission, Office of Workers Compensation Administration, LR 37:1750 (June 2011), LR 47:1656 (November 2021).

### §2217. General Guidelines Principles

A. The principles summarized in this section are key to the intended implementation of all Office of Workers’



Compensation medical treatment guidelines and critical to the reader's application of the guidelines in this document.

1. **Application of Guidelines.** The OWCA provides procedures to implement medical treatment guidelines and to foster communication to resolve disputes among the provider, payer, and patient through the Workers' Compensation Act.

2. **Education.** Education of the patient and family, as well as the employer, insurer, policy makers and the community should be the primary emphasis in the treatment of workers' compensation injuries. Currently, practitioners often think of education last, after medications, manual therapy, and surgery. Practitioners must implement strategies to educate patients, employers, insurance systems, policy makers, and the community as a whole. An education-based paradigm should always start with inexpensive communication providing reassuring and evidence-based information to the patient. More in-depth education is currently a component of treatment regimens which employ functional restorative, preventive and rehabilitative programs. No treatment plan is complete without addressing issues of individual and/or group patient education as a means of facilitating self-management of symptoms and prevention. Facilitation through language interpretation, when necessary, is a priority and part of the medical care treatment protocol.

3. **Informed Decision Making.** Providers should implement informed decision making as a crucial element of a successful treatment plan. Patients, with the assistance of their health care practitioner, should identify their personal and professional functional goals of treatment at the first visit when a chronic pain condition allows functional improvement. Progress towards the individual's identified functional goals should be addressed by all members of the health care team at subsequent visits and throughout the established treatment plan when a chronic pain condition allows attainment of functional goals. Injured workers may not reach functional goals to return to work and therefore they will require a significantly different plan. Nurse case managers, physical therapists, and other members of the health care team play an integral role in informed decision-making and achievement of functional goals. Patient education and informed decision-making should facilitate self-management of symptoms and prevention of further injury.

4. **Treatment Parameter Duration.** Time frames for specific interventions commence once treatments have been initiated, not on the date of injury. Obviously, duration will be impacted by patient adherence, as well as availability of services. Clinical judgment may substantiate the need to accelerate or decelerate the time frames discussed in this document. Such deviation shall be in accordance with La. R.S. 23:1203.1.

5. **Active interventions** emphasizing patient responsibility, such as therapeutic exercise and/or functional treatment, are generally emphasized over passive modalities, especially as treatment progresses. Generally, passive

interventions are viewed as a means to facilitate progress in an active rehabilitation program with concomitant attainment of objective functional gains.

6. **Active Therapeutic Exercise Program.** Exercise program goals should incorporate patient strength, endurance, flexibility, coordination, and education. This includes functional application in vocational or community settings.

7. **Positive Patient Response.** Positive results are defined primarily as functional gains that can be objectively measured.

a. Objective functional gains include, but are not limited to, positional tolerances, range-of-motion (ROM), strength, and endurance, activities of daily living, ability to function at work, cognition, psychological behavior, and efficiency/velocity measures that can be quantified. Subjective reports of pain and function should be considered and given relative weight when the pain has anatomic and physiologic correlation. Anatomic correlation must be based on objective findings.

8. **Re-Evaluation of Treatment Every Three to Four Weeks.** If a given treatment or modality is not producing positive results within three to four weeks, the treatment should be either modified or discontinued. Reconsideration of diagnosis should also occur in the event of poor response to a seemingly rational intervention.

9. **Surgical Interventions.** Surgery should be contemplated within the context of expected functional outcome and not purely for the purpose of pain relief. The concept of "cure" with respect to surgical treatment by itself is generally a misnomer. All operative interventions must be based upon positive correlation of clinical findings, clinical course, and diagnostic tests. A comprehensive assimilation of these factors must lead to a specific diagnosis with positive identification of pathologic conditions.

10. **Pharmacy-Louisiana Law and Regulation.** All prescribing will be done in accordance with the laws of the state of Louisiana as they pertain respectively to each individual licensee, including, but not limited to: Louisiana State Board of Medical Examiners regulations governing medications used in the treatment of non-cancer-related chronic or intractable pain; Louisiana Board of Pharmacy Prescription Monitoring Program; Louisiana Department of Health and Hospitals licensing and certification standards for pain management clinics; other laws and regulations affecting the prescribing and dispensing of medications in the state of Louisiana.

11. **Six Month-Time Frame.** Injuries resulting in temporary total disability require maintenance treatment and may not attain return to work in six months.

12. **Return to Work.** Return to work is therapeutic, assuming the work is not likely to aggravate the basic problem or increase long-term pain. An injured worker's return-to-work status shall not be the sole cause to deny reasonable and medically necessary treatment under these guidelines. Two good practices are: early contact with

injured workers and provide modified work positions for short-term injuries. The practitioner may provide specific physical limitations and the patient should never be released to non-specific and vague descriptions such as sedentary or light duty. The following physical limitations should be considered and modified as recommended: lifting, pushing, pulling, crouching, walking, using stairs, bending at the waist, awkward and/or sustained postures, tolerance for sitting or standing, hot and cold environments, data entry and other repetitive motion tasks, sustained grip, tool usage and vibration factors. Even if there is residual chronic pain, return-to-work is not necessarily contraindicated. The practitioner should understand all of the physical demands of the patient’s job position before returning the patient to full duty and should request clarification of the patient’s job duties. Clarification should be obtained from the employer or, if necessary, from including, but not limited to, occupational health nurse, physical therapist, occupational therapist, vocational rehabilitation specialist, an industrial hygienist, chiropractor or another professional. American Medical Association clarifies “disability” as “activity limitations and/or participation restrictions in an individual with a health condition, disorder or disease” versus “impairment” as “a significant deviation, loss, or loss of use of any body structure or body function in an individual with a health condition, disorder or disease”.

13. Delayed Recovery. Within the discretion of the treating physician, strongly consider a psychological evaluation, if not previously provided, as well as initiating interdisciplinary rehabilitation treatment and vocational goal setting, for those patients who are failing to make expected progress 6 to 12 weeks after initiation of treatment of an injury. The OWCA recognizes that 3 to 10 percent of all industrially injured patients will not recover within the timelines outlined in this document despite optimal care. Such individuals may require treatments beyond the limits discussed within this document, but such treatment requires clear documentation by the authorized treating practitioner focusing on objective functional gains afforded by further treatment and impact upon prognosis.

14. Guideline Recommendations and Inclusion of Medical Evidence. Guidelines are recommendations based on available evidence and/or consensus recommendations. When possible, guideline recommendations will note the level of evidence supporting the treatment recommendation. When interpreting medical evidence statements in the guideline, the following apply to the strength of recommendation.

Strong	Level 1 Evidence	We Recommend
Moderate	Level 2 and Level 3 Evidence	We Suggest
Weak	Level 4 Evidence	Treatment is an Option
Inconclusive	Evidence is Either Insufficient or Conflicting	

a. Consensus guidelines are generated by a professional organization that the guidelines are intended to serve. A committee of specialists and experts are selected by the organization to create an unbiased, vetted recommendation for the treatment of specific issues within

the realm of their expertise. All recommendations in the guideline are considered to represent reasonable care in appropriately selected cases, regardless of the level of evidence or consensus statement attached to it. Those procedures considered inappropriate, unreasonable, or unnecessary are designated in the guideline as not recommended.

15. Treatment of Pre-Existing Conditions The conditions that preexisted the work injury/disease will need to be managed under two circumstances:

a. A pre-existing condition exacerbated by a work injury/disease should be treated until the patient has returned to their objectively verified prior level of functioning or Maximum Medical Improvement (MMI); and

b. A pre-existing condition not directly caused by a work injury/disease but which may prevent recovery from that injury should be treated until its objectively verified negative impact has been controlled. The focus of treatment should remain on the work injury/disease.

B. The remainder of this document should be interpreted within the parameters of these guideline principles that may lead to more optimal medical and functional outcomes for injured workers.

AUTHORITY NOTE: Promulgated in accordance with R.S. 23:1203.1.

HISTORICAL NOTE: Promulgated by the Louisiana Workforce Commission, Office of Workers Compensation Administration, LR 37:1750 (June 2011), amended by the Louisiana Workforce Commission, Office of Workers Compensation, LR 40:1159 (June 2014), LR 47:1656 (November 2021).

**§2219. Definition of Thoracic Outlet Syndrome**

A. Thoracic Outlet Syndrome (TOS) may be described as a neurovascular disorder affecting the upper extremity which, on rare occasions, is caused by workplace factors, such as jobs that require repetitive activities of the upper extremities with forward head and shoulder postures. It should be emphasized that occupational TOS is a relatively uncommon disorder and other disorders with similar symptomatology need to be ruled out.

B. There are four types of thoracic outlet syndrome. The two vascular types, comprised of subclavian vein or artery pathology, are diagnosed with imaging. True or classic neurogenic TOS consists of a chronic lower trunk brachial plexopathy diagnosed by positive electrodiagnostic testing. It is usually unilateral, predominantly affects women, and results in classic electrophysiologic and physical exam findings such as hand atrophy. The two vascular types of TOS and true neurogenic are relatively rare and easily diagnosed. The most common type of TOS is non-specific neurogenic (also called disputed) TOS, which is diagnosed based on upper or lower trunk brachial plexus symptoms.

AUTHORITY NOTE: Promulgated in accordance with R.S. 23:1203.1.

HISTORICAL NOTE: Promulgated by the Louisiana Workforce Commission, Office of Workers Compensation Administration, LR 37:1751 (June 2011).

## §2221. Initial Diagnostic Procedures

A. The OWCA recommends the following diagnostic procedures be considered, at least initially, the responsibility of the workers' compensation carrier to ensure that an accurate diagnosis and treatment plan can be established. Standard procedures that should be utilized when initially diagnosing a work-related TOS complaint are listed below.

1. History taking and physical examination (Hx and PE) are generally accepted, well-established and widely used procedures which establish the basis for diagnosis, and dictate all other diagnostic and therapeutic procedures. When findings of clinical evaluations and those of other diagnostic procedures are not complementing each other, the objective clinical findings should have preference. Neurogenic TOS will be described separately from vascular TOS, although some general symptoms may occasionally overlap. Vascular TOS usually requires emergent treatment as described in the surgical Section. Treatment for non-specific neurogenic TOS begins with jobsite alteration and therapy as described in Section F. and rarely requires surgical intervention. True neurogenic TOS may require early surgical intervention if there is significant weakness with corresponding EMG/NCV changes. The medical records should reasonably document the following.

a. History Taking. A careful history documenting exacerbating activities and positions which relieve symptoms is essential. Timing of the onset of symptoms is important. TOS has been associated with trauma and motor vehicle accidents. Avocational pursuits should also be specifically documented.

i. Symptoms Common to Neurogenic TOS. Neurological symptoms are usually intermittent in non-specific TOS. If symptoms are constant, consider other diagnoses such as true TOS or other brachial plexus injuries. Neck pain is often the first symptom with complaints within the first few days of injury. Occipital headaches may also occur early. Some patients experience coldness or color changes in the hands. Neurogenic symptoms include the following:

(a). forearm (frequently medial), or proximal upper extremity pain;

(b). numbness and paresthesia in arm, hand and fingers:

(i). fourth and fifth digits: most common pattern;

(ii). all five fingers: next most common pattern;

(iii).first, second and third digits: symptoms may occur, but one must rule out carpal tunnel syndrome;

(c). upper extremity weakness: arm and/or hand; "dropping things" may be a common complaint;

(d). exacerbating factor: arm elevation. Common complaints are trouble combing hair, putting on clothing,

driving a car, or carrying objects with shoulder straps such as back packs; disturbed sleep, etc.

### (i). Symptoms Common to Vascular TOS

[a]. Pain, coldness, pallor, digital ischemia and claudication in the forearm are signs of arterial compromise which is most frequently chronic and due to subclavian aneurysm or stenosis.

[b]. Swollen, cyanotic, and sometimes painful arm is indicative of a venous obstruction requiring immediate attention.

b. Occupational Relationship for Neurogenic and Vascular TOS. In many cases, trauma is the cause vascular or neurogenic TOS. Clavicular fractures, cervical strain (including whiplash), and other cases of cervical trauma injuries have been associated with TOS. Continual overhead lifting or motion may contribute as can static postures in which the shoulders droop and the head is inclined forward. Activities which cause over-developed scalene muscles such as weight-lifting and swimming may contribute. The Paget-Schroetter syndrome, or effort thrombosis of the subclavian vein, may occur in athletes or workers with repetitive overhead forceful motion and neck extension. Arterial thrombosis or symptoms from subclavian aneurysms or stenosis are usually not work-related. Both classic neurogenic TOS (usually due to a cervical or anomalous first rib) and vascular TOS due to arterial compromise from stenosis or aneurysm are rarely work-related conditions.

### c. Physical Findings

i. Physical Examination Signs used to Diagnose Classic or Non-specific Neurogenic TOS. Both extremities should be examined to compare symptomatic and asymptomatic sides.

ii. Provocative maneuvers (listed below) must reproduce the symptoms of TOS to be considered positive:

(a). tenderness over scalene muscles in supraclavicular area;

(b). pressure in supraclavicular area elicits symptoms in arm/hand, or Tinel's sign over brachial plexus is positive. The supraclavicular pressure test is positive for paresthesia in approximately 15 percent of asymptomatic individuals;

(c). Elevated Arm Stress Test (EAST) is performed with the arms abducted and shoulders externally rotated to 90 degrees with elbows bent to 90 degrees for 3 minutes (some examiners use 60 seconds). The patient may also be asked to repetitively open and close fists. A positive test reproduces upper extremity symptoms. When this test is performed for 3 minutes in an asymptomatic population, approximately 35 percent experience paresthesia;

(d). some literature has suggested another provocative elevated arm stress test. The patient holds his arms over head for one minute with elbows extended, wrists in a neutral position, and forearm midway between

supination and pronation. If symptoms are reproduced, the test is positive.

d. Posture related brachial tests:

i. head tilting: lateral flexion of the neck (ear to shoulder) causes radiating pain and paresthesia in the contralateral arm consistent with TOS.;

ii. Military posture or costoclavicular maneuver. Shoulders are depressed and pulled backward in an exaggerated position. Reproduction of symptoms is a positive test. Approximately 15 percent of asymptomatic individuals will report paresthesia with this test.

e. Neurological Examination: usually normal in non-specific TOS, but may be abnormal.

i. Sensory Exam: may show decreased sensation to light touch, pain, vibration, and/or temperature in lower brachial plexus distribution. The entire ring finger is usually involved. This contrasts with ulnar neuropathy, which usually involves only the ulnar side of the ring finger.

ii. Motor Exam: weakness and/or muscle atrophy in either upper or lower trunk distributions including, but not limited to, valid dynamometer readings indicative of relative weakness in the affected limb. In lower plexus injuries, the abductor pollicis brevis often demonstrates more involvement and atrophy than the intrinsic interosseous muscles.

(a). Physical exam findings for vascular TOS cases. Suspicion of vascular compromise should lead to confirmation using appropriate imaging procedures.

(i). Arterial cases usually demonstrate an absent radial pulse at rest, pale hand and often ischemic fingers.

(ii). Venous obstruction presents with visible or distended superficial veins on the effected signs involving the anterior axillary fold and chest wall. The arm is usually swollen and cyanotic.

iii. Physical Exam—other tests which are recommended and may indicate additional diagnostic considerations.

(a). Neck rotation may be restricted and can indicate the presence of additional pathology.

(b). Upper Limb Tension Test—this provocative test may be positive for cervical radiculopathy, brachial plexus pathology, or other peripheral nerve pathology. It is considered sensitive but non-specific. The test has several variations; however, they all consist of a series of systematic maneuvers performed on the upper quadrant to evaluate peripheral nerve function and pathology. Head tilting is one of the maneuvers included. Provocation of abnormal responses indicates neural tissue sensitization/irritation, and can include implication of specific peripheral nerve trunks. Performance and interpretation of this test requires specific training and experience. A negative response to the upper limb tension test makes the diagnosis of neurogenic TOS unlikely. If negative, investigate other diagnoses.

(c). Rotator cuff/acromioclavicular (AC) joint tenderness suggests rotator cuff, or biceps tendonitis or AC joint disease.

(d). Trapezius muscle, shoulder girdle muscles or paraspinal muscle tenderness suggests a myofascial component.

(e). Drooping shoulders secondary to nerve injuries can be present with TOS symptoms. If a spinal accessory, long thoracic or other nerve injury is identified, treatment should focus on therapy for the nerve injury in addition to conservative measures for TOS. Refer to the Shoulder Injury Medical Treatment Guidelines. Brachial Plexus and Shoulder Nerve Injuries.

(f). The following tests suggest carpal tunnel syndrome:

(i). carpal tunnel compression test;

(ii). flicking the wrist secondary to paresthesia;

(iii). Tinel's sign; and/or

(iv). Phalen's sign.

(g). Positive Tinel's sign at elbow (over ulnar groove) suggests ulnar nerve entrapment.

(h). Positive Tinel's sign over the pronator teres muscle suggests median nerve involvement. Positive Tinel's sign over the radial tunnel suggests radial nerve compression.

f. Cervical spine x-ray is a generally accepted, well-established procedure indicated to rule out cervical spine disease, fracture, cervical rib or rudimentary first rib when clinical findings suggest these diagnoses. Cervical spine x-rays should also be considered when there is an asymmetric diminished pulse in an arm that is symptomatic. X-rays are most useful when arterial TOS is suspected. The presence of a cervical rib does not confirm the diagnosis unless other clinical signs and symptoms are present, as many cervical ribs are asymptomatic. Therefore, routine roentgenographic evaluation of the cervical spine is frequently unnecessary early in the course of treatment for non-specific TOS.

g. Vascular Studies. Vascular laboratory studies, including duplex scanning, Doppler studies, standard and MR arteriography and venography are required for patients presenting with arterial or venous occlusion, as these patients may require immediate thrombolytic intervention. These studies are not indicated for neurogenic TOS.

AUTHORITY NOTE: Promulgated in accordance with R.S. 23:1203.1.

HISTORICAL NOTE: Promulgated by the Louisiana Workforce Commission, Office of Workers Compensation Administration, LR 37:1751 (June 2011).

**§2223. Follow-up Diagnostic Imaging and Testing Procedures**

A. Cervical computed axial tomography or magnetic resonance imaging (ct/mri) are generally accepted, well-

established procedures indicated to rule out cervical disc or other cervical spine disorders when clinical findings suggest these diagnoses. It should not be routinely performed for TOS. MRI is the preferred test over a CT unless a fracture is suspected, and then CT may be superior to MRI. CT/MRI is not indicated early unless there is a neurological deficit and/or the need to rule out a space-occupying lesion, such as a tumor. Repeat cervical MRI is not indicated for TOS. If cervical spine injury is confirmed, refer to the OWCA's *Cervical Spine Injury Medical Treatment Guidelines*. If a cervical spine disorder is not suspected, conservative therapy as indicated in Section F, Non-operative Procedures should be done for at least 8 to 12 weeks, prior to ordering an MRI for persistent symptoms.

#### B. Electrodiagnostic Studies

1. Electromyography/Nerve Conduction Velocities (EMG/NCV) is a generally accepted, well-established procedure. EMG/NCV is primarily indicated to rule out other nerve entrapment syndromes such as carpal tunnel or cubital tunnel syndrome when indicated by clinical examination, or to establish true neurogenic TOS. Most cases of non-specific TOS have normal electrodiagnostic studies, but EMG/NCV should be considered when symptoms have been present for approximately three months or if the patient has failed eight weeks of conservative therapy. EMG/NCV may also be performed to rule out other disorders. Somato-sensory evoked potentials (SSEPs), F waves and NCV across the thoracic outlet have no diagnostic value and should not be performed. The diagnosis is usually made by comparison to the normal extremity. For bilateral disease, each EMG lab must establish its own absolute limits of latency and amplitude from volunteer controls so that measurements exceeding these limits can be noted.

#### 2. Criteria for True Neurogenic TOS

a. reduction of the ulnar sensory nerve action potential to digits (usually less than 60 percent of unaffected side); or

b. medial antebrachial sensory action potential which is low or absent compared to the unaffected side; or

c. reduction of the median M-wave amplitude (usually less than 50 percent of unaffected side); or

d. needle EMG examination reveals neurogenic changes in intrinsic hand muscles and the abductor pollicis brevis muscle.

3. Portable automated electrodiagnostic device: (also known as surface EMG) is not a substitute for conventional EMG/NCS testing in clinical decision-making, and therefore, is not recommended.

4. Quantitative Sensory Testing (QST). Research is not currently available on the use of QST in the evaluation of TOS. QST tests the entire spectrum of the neurological system including the brain. It is not able to reliably distinguish between organic and psychogenic pathology and therefore, is not recommended.

C. Vascular Studies. Noninvasive vascular testing, such as pulse-volume recording in different positions, is not indicated in cases of neurogenic TOS. Since the presence or absence of a pulse cutoff on physical examination is not helpful in establishing a diagnosis of TOS, the recording of finer degrees of positional pulse alteration will not add to the diagnosis. Vascular laboratory studies, including duplex scanning, Doppler studies, standard and MR arteriography and venography, are not cost-effective in cases of neurogenic TOS. These studies are only indicated in patients who have arterial or venous occlusive signs. Dynamic venography with the arm in 180 degrees of abduction may be used in cases with continued swelling and/or periodic cyanosis who have not improved with conservative therapy. Approximately 20 percent of asymptomatic individuals will have an abnormal dynamic venogram. Some individuals may have a pectoralis minor syndrome which occludes the axillary vein rather than the subclavian vein. In these cases, less invasive surgery than the TOS operative procedures may be indicated.

D. Thermography is not generally accepted or widely used for TOS. It may be used if differential diagnosis includes CRPS; in such cases refer to the OWCA's *Complex Regional Pain Syndrome/Reflex Sympathetic Dystrophy Medical Treatment Guidelines*.

E. Anterior scalene or pectoralis muscle blocks may be performed to provide additional information prior to expected surgical intervention. It is recommended that EMG or sonography guidance be used to assure localization.

F. Personality/psychological/psychiatric/psychosocial evaluations are generally accepted and well-established diagnostic procedures with selective use in the acute TOS population and more widespread use in the sub-acute and chronic TOS population.

1. Diagnostic testing procedures may be useful for patients with symptoms of depression, delayed recovery, chronic pain, recurrent painful conditions, disability problems, and for pre-operative evaluation as well as a possible predictive value for post-operative response. Psychological testing should provide differentiation between pre-existing depression versus injury-caused depression, as well as post-traumatic stress disorder.

2. Formal psychological or psychosocial evaluation should be performed on patients not making expected progress within 6-12 weeks following injury and whose subjective symptoms do not correlate with objective signs and tests. In addition to the customary initial exam, the evaluation of the injured worker should specifically address the following areas:

a. employment history;

b. interpersonal relationships—both social and work;

c. leisure activities;

d. current perception of the medical system;

e. results of current treatment;

- f. perceived locus of control; and
- g. childhood history, including abuse and family history of disability.

3. This information should provide clinicians with a better understanding of the patient, and enable a more effective rehabilitation.

4. The evaluation will determine the need for further psychosocial interventions, and in those cases, a Diagnostic Statistical Manual (DSM) of Mental Disorders diagnosis should be determined and documented. An individual with a PhD, PsyD, or Psychiatric MD/DO credentials should perform initial evaluations, which are generally completed within one to two hours. A professional fluent in the primary language of the patient is strongly preferred. When such a provider is not available, services of a professional language interpreter must be provided. When issues of chronic pain are identified, the evaluation should be more extensive and follow testing procedures as outlined in the OWCA's *Chronic Pain Disorder Medical Treatment Guidelines*.

a. Frequency—one time visit for evaluation. If psychometric testing is indicated as a portion of the initial evaluation, time for such testing shall be allotted at least, six hours of professional time or whatever is deemed appropriate by the health care professional.

G. Special tests are generally well-accepted tests and are performed as part of a skilled assessment of the patients' capacity to return to work, his/her strength capacities, and physical work demand classifications and tolerance. The procedures in this subsection are listed in alphabetical order, not by importance.

1. Computer-enhanced evaluations may include isotonic, isometric, isokinetic and/or isoinertial measurement of movement, range-of-motion, endurance or strength. Values obtained can include degrees of motion, torque forces, pressures or resistance. Indications include determining validity of effort, effectiveness of treatment and demonstrated motivation. These evaluations should not be used alone to determine return to work restrictions. The added value of computer enhanced evaluations is unclear. Targeted work tolerance screening or gradual return to work is preferred.

a. Frequency—one time for evaluation. Can monitor improvements in strength every three to four weeks up to a total of six evaluations.

2. Functional capacity evaluation (FCE) is a comprehensive or modified evaluation of the various aspects of function as they relate to the worker's ability to return to work. Areas such as endurance, lifting (dynamic and static), postural tolerance, specific range of motion, coordination and strength, worker habits, employability as well as psychosocial, cognitive, and sensory perceptual aspects of competitive employment may be evaluated. Components of this evaluation may include: musculoskeletal screen; cardiovascular profile/aerobic capacity; coordination; lift/carrying analysis; job-specific activity tolerance;

maximum voluntary effort; pain assessment/psychological screening; and non-material and material handling activities.

a. When an FCE is being used to determine return to a specific jobsite, the provider is responsible for fully understanding the job duties. A jobsite evaluation is frequently necessary. FCEs cannot be used in isolation to determine work restrictions. The authorized treating physician must interpret the FCE in light of the individual patient's presentation and medical and personal perceptions. FCEs should not be used as the sole criteria to diagnose malingering.

b. Full FCEs are sometimes necessary. In many cases, a work tolerance screening will identify the ability to perform the necessary job tasks. If partial FCEs are performed, it is recognized that all parts of the FCE that are not performed are considered normal.

i. Frequency—can be used initially to determine baseline status and for case closure when patient is unlikely to return to pre-injury position and further information is desired to determine permanent work restrictions. Prior authorization is required for FCEs performed during treatment.

3. Jobsite evaluation is a comprehensive analysis of the physical, mental and sensory components of a specific job. These components may include, but are not limited to: postural tolerance (static and dynamic); aerobic requirements; range of motion; torque/force; lifting/carrying; cognitive demands; social interactions; visual perceptual; sensation; coordination; environmental requirements; repetitiveness; and essential job functions. Job descriptions provided by the employer are helpful but should not be used as a substitute for direct observation.

a. A jobsite evaluation may include observation and instruction of how work is done, what material changes (desk, chair) should be made, and determination of readiness to return to work. Postural risk factors should be identified and awkward postures of overhead reach, hyperextension or rotation of the neck, shoulder drooped or forward-flexed and head-chin forward postures should be eliminated. Unless combined with one of the above postures, repetitiveness is not by itself a risk factor. Refer to Cumulative Trauma Disorder and Shoulder Guidelines for further suggestions.

i. Requests for a jobsite evaluation should describe the expected goals for the evaluation. Goals may include, but are not limited to the following:

(a). to determine if there are potential contributing factors to the person's condition and/or for the physician to assess causality;

(b). to make recommendations for, and to assess the potential for ergonomic changes;

(c). to provide a detailed description of the physical and cognitive job requirements;

(d). to assist the patient in their return to work by educating them on how they may be able to do their job more safely in a bio-mechanically appropriate manner;

(e). to give detailed work/activity restrictions.

(i). Frequency—one time with additional visits as needed for follow-up per jobsite.

4. Vocational Assessment. The vocational assessment should provide valuable guidance in the determination of future rehabilitation program goals. It should clarify rehabilitation goals, which optimize both patient motivation and utilization of rehabilitation resources. If prognosis for return to former occupation is determined to be poor, except in the most extenuating circumstances, vocational assessment should be implemented within 3 to 12 months post-injury. Declaration of MMI should not be delayed solely due to lack of attainment of a vocational assessment.

a. Frequency—one time with additional visits as needed for follow-up.

5. Work tolerance screening is a determination of an individual's tolerance for performing a specific job based on a job activity or task and may be used when a full functional capacity evaluation is not indicated. The screening is monitored by a therapist and may include a test or procedure to specifically identify and quantify work-relevant cardiovascular, physical fitness and postural tolerance. It may also address ergonomic issues affecting the patient's return-to-work potential.

a. Frequency—one time for initial screen. May monitor improvements in strength every three to four weeks up to a total of six visits.

AUTHORITY NOTE: Promulgated in accordance with R.S. 23:1203.1.

HISTORICAL NOTE: Promulgated by the Louisiana Workforce Commission, Office of Workers Compensation Administration, LR 37:1753 (June 2011), amended LR 47:1657 (November 2021).

### §2225. Therapeutic Procedures—Non-Operative

NOTE: Treating providers, as well as employers and insurers are highly encouraged to reference the General Guideline Principles prior to initiation of any therapeutic procedure.

A. Initial Treatment Recommendations. Vascular cases will require surgical management and thus are not appropriate candidates for initial non-operative therapy. Cases of “non-specific” (also called disputed) TOS are treated conservatively first for a minimum of three months. Patients undergoing therapeutic procedures may return to modified or restricted duty during their rehabilitation, at the earliest appropriate time. Cessation and/or review of treatment modalities should be undertaken when no further significant subjective or objective improvement in the patient's condition is noted. Most literature of conservative therapy for TOS suggest benefit for patients with non-specific TOS. Non-surgical patients may be less likely to lose as much time from work as surgical patients. Initial treatment for TOS patients without indications for early surgery should include, patient education, jobsite alterations (especially if job activities are related to symptoms), neuromuscular education to emphasis proper breathing techniques and posture, nerve gliding and core body therapeutic exercise.

B. Postural risk factors should be identified. Awkward postures of overhead reach, hyperextension or rotation of the neck, shoulder drooped or forward-flexed and head-chin forward postures should be eliminated. Proper breathing techniques are also part of the treatment plan.

C. Therapy is primarily a daily self-managed home program developed and supervised by an appropriately trained professional. Nerve gliding and upper extremity stretching usually involves the following muscle groups: scalene, pectoralis minor, trapezius and levator scapulae. Endurance or strengthening of the upper extremities early in the course of therapy is not recommended, as this may exacerbate cervical or upper extremity symptoms.

D. Jobsite evaluation should be done early in all non-traumatic cases and should be performed by a qualified individual in all cases of suspected occupational TOS. Postural risk factors discussed above should be considered when making jobsite changes. Unless combined with one of the above postures, repetition alone is not a risk factor. Work activities need to be modified early in treatment to avoid further exposure to risk factors.

1. Acupuncture is an accepted and widely used procedure for the relief of pain and inflammation and there is some scientific evidence to support its use. The exact mode of action is only partially understood. Western medicine literature suggests that acupuncture stimulates the nervous system at the level of the brain, promotes deep relaxation, and affects the release of neurotransmitters. Acupuncture is commonly used as an alternative or in addition to traditional Western pharmaceuticals. While it is commonly used when pain medication is reduced or not tolerated, it may be used as an adjunct to physical rehabilitation and/or surgical intervention to hasten the return of functional activity. Acupuncture should be performed by licensed practitioners.

a. Acupuncture is the insertion and removal of filiform needles to stimulate acupoints (acupuncture points). Needles may be inserted, manipulated and retained for a period of time. Acupuncture can be used to reduce pain, reduce inflammation, increase blood flow, increase range of motion, decrease the side effect of medication-induced nausea, promote relaxation in an anxious patient, and reduce muscle spasm.

i. Indications include joint pain, joint stiffness, soft tissue pain and inflammation, paresthesia, post-surgical pain relief, muscle spasm, and scar tissue pain.

b. Acupuncture with electrical stimulation is the use of electrical current (micro-amperage or milli-amperage) on the needles at the acupuncture site. It is used to increase effectiveness of the needles by continuous stimulation of the acupoint. Physiological effects (depending on location and settings) can include endorphin release for pain relief, reduction of inflammation, increased blood circulation, analgesia through interruption of pain stimulus, and muscle relaxation.

i. It is indicated to treat chronic pain conditions, radiating pain along a nerve pathway, muscle spasm, inflammation, scar tissue pain, and pain located in multiple sites.

c. Total time frames for acupuncture and acupuncture with electrical stimulation time frames are not meant to be applied to each of the above sections separately. The time frames are to be applied to all acupuncture treatments regardless of the type or combination of therapies being provided.

i. Time to Produce Effect—three to six treatments.

ii. Frequency—one to three times per week.

iii. Optimum Duration—one to two months.

iv. Maximum Duration—14 treatments.

(a). Any of the above acupuncture treatments may extend longer if objective functional gains can be documented or when symptomatic benefits facilitate progression in the patient's treatment program. Treatment beyond 14 treatments must be documented with respect to need and ability to facilitate positive symptomatic or functional gains. Such care should be re-evaluated and documented with each series of treatments.

d. Other Acupuncture Modalities. Acupuncture treatment is based on individual patient needs and therefore treatment may include a combination of procedures to enhance treatment effect. Other procedures may include the use of heat, soft tissue manipulation/massage, and exercise. Refer to Active Therapy (Therapeutic Exercise) and, Passive Therapy sections (Massage and Superficial Heat and Cold Therapy) for a description of these adjunctive acupuncture modalities and time frames.

2. Biofeedback is a form of behavioral medicine that helps patients learn self-awareness and self-regulation skills for the purpose of gaining greater control of their physiology, such as muscle activity, brain waves, and measures of autonomic nervous system activity. Electronic instrumentation is used to monitor the targeted physiology and then displayed or fed back to the patient visually, auditorily, or tactilely, with coaching by a biofeedback specialist. Biofeedback is provided by clinicians certified in biofeedback and/or who have documented specialized education, advanced training, or direct or supervised experience qualifying them to provide the specialized treatment needed (e.g., surface EMG, EEG, or other).

a. Treatment is individualized to the patient's work-related diagnosis and needs. Home practice of skills is required for mastery and may be facilitated by the use of home training tapes. The ultimate goal in biofeedback treatment is normalizing the physiology to the pre-injury status to the extent possible and involves transfer of learned skills to the workplace and daily life. Candidates for biofeedback therapy or training must be motivated to learn and practice biofeedback and self-regulation techniques.

b. Indications for biofeedback include individuals who are suffering from musculoskeletal injury where muscle dysfunction or other physiological indicators of excessive or prolonged stress response affects and/or delays recovery. Other applications include training to improve self-management of emotional stress/pain responses such as anxiety, depression, anger, sleep disturbance, and other central and autonomic nervous system imbalances. Biofeedback is often utilized along with other treatment modalities.

i. Time to Produce Effect—three to four sessions.

ii. Frequency—one to two times per week.

iii. Optimum Duration—five to six sessions.

iv. Maximum Duration: 10 to 12 sessions. Treatment beyond 12 sessions must be documented with respect to need, expectation, and ability to facilitate positive symptomatic or functional gains.

### 3. Injections—Therapeutic

a. Scalene blocks have no therapeutic role in the treatment of TOS.

b. Trigger point injections, although generally accepted, are not routinely used in cases of TOS. However, it is not unusual to find myofascial trigger points associated with TOS pathology, which may require injections.

i. Description. Trigger point treatment can consist of dry needling or injection of local anesthetic with or without corticosteroid into highly localized, extremely sensitive bands of skeletal muscle fibers that produce local and referred pain when activated. Medication is injected in a four-quadrant manner in the area of maximum tenderness. Injection efficacy can be enhanced if injections are immediately followed by myofascial therapeutic interventions, such as vapo-coolant spray and stretch, ischemic pressure massage (myotherapy), specific soft tissue mobilization and physical modalities. There is conflicting evidence regarding the benefit of trigger point injections. A truly blinded study comparing dry needle treatment of trigger points is not feasible. There is no evidence that injection of medications improves the results of trigger-point injections. Needling alone may account for some of the therapeutic response.

ii There is no indication for conscious sedation for patients receiving trigger point injections. The patient must be alert to help identify the site of the injection.

iii. Indications. Trigger point injections may be used to relieve myofascial pain and facilitate active therapy and stretching of the affected areas. They are to be used as an adjunctive treatment in combination with other treatment modalities such as functional restoration programs. Trigger point injections should be utilized primarily for the purpose of facilitating functional progress. Patients should continue with a therapeutic exercise program as tolerated throughout the time period they are undergoing intensive myofascial interventions. Myofascial pain is often associated with other



underlying structural problems and any abnormalities need to be ruled out prior to injection.

iv. Trigger point injections are indicated in those patients where well circumscribed trigger points have been consistently observed, demonstrating a local twitch response, characteristic radiation of pain pattern and local autonomic reaction, such as persistent hyperemia following palpation. Generally, these injections are not necessary unless consistently observed trigger points are not responding to specific, noninvasive, myofascial interventions within approximately a six-week time frame.

v. Complications. Potential but rare complications of trigger point injections include infection, pneumothorax, anaphylaxis, neurapraxia, and neuropathy. If corticosteroids are injected in addition to local anesthetic, there is a risk of local myopathy developing. Severe pain on injection suggests the possibility of an intraneural injection, and the needle should be immediately repositioned.

(a). Time to Produce Effect—local anesthetic, 30 minutes; no anesthesia, 24 to 48 hours.

(b). Frequency—weekly, suggest no more than four injection sites per session per week to avoid significant post-injection soreness.

(c). Optimal Duration—four weeks.

(d). Maximum Duration—eight weeks. Occasional patients may require two to four repetitions of trigger point injection series over a one to two year period.

#### 4. Medications:

a. Thrombolytic agents will be required for some vascular TOS conditions.

b. Medication use is appropriate for pain control in TOS. A thorough medication history, including use of alternative and over the counter medications, should be performed at the time of the initial visit and updated periodically.

c. Acetaminophen is an effective and safe initial analgesic. Nonsteroidal anti-inflammatory drugs (NSAIDs) are useful in the treatment of inflammation, and for pain control. Pain is subjective in nature and should be evaluated using a scale to rate effectiveness of the analgesic in terms of functional gain. Other medications, including antidepressants and anti-convulsants, may be useful in selected patients with neuropathic and/or chronic pain (Refer to the OWCA's *Chronic Pain Guidelines*). Narcotics are rarely indicated for treatment of TOS, and they should be primarily reserved for the treatment of acute severe pain for a limited time on a case-by-case basis. Topical agents may be beneficial in the management of localized upper extremity pain.

d. The use of a patient completed pain drawing, Visual Analog Scale (VAS), is highly recommended to help providers track progress. Functional objective goals should be monitored regularly to determine the effectiveness of treatment. The patient should be advised regarding the

interaction with prescription and over-the-counter herbal products.

e. The following medications are listed in alphabetical order.

i. Acetaminophen is an effective analgesic with antipyretic but not anti-inflammatory activity. Acetaminophen is generally well tolerated, causes little or no gastrointestinal irritation and is not associated with ulcer formation. Acetaminophen has been associated with liver toxicity in overdose situations or in chronic alcohol use. Patients may not realize that many over-the-counter preparations may contain acetaminophen. The total daily dose of acetaminophen is recommended not to exceed 2250 mg per 24 hour period, from all sources, including narcotic-acetaminophen combination preparations.

(a). Optimal Duration—7 to 10 days.

(b). Maximum Duration—chronic use as indicated on a case-by-case basis. Use of this substance long-term for three days per week or greater may be associated with rebound pain upon cessation.

ii. Anticonvulsants. Although the mechanism of action of anticonvulsant drugs in neuropathic pain states remains to be fully defined, they appear to act as nonselective sodium channel blocking agents. A large variety of sodium channels are present in nervous tissue, and some of these are important mediators of nociception, as they are found primarily in unmyelinated fibers and their density increases following nerve injury. While the pharmacodynamic effects of the various anticonvulsant drugs are similar, the pharmacokinetic effects differ significantly. Carbamazepine has important effects as an inducer of hepatic enzymes and may influence the metabolism of other drugs enough to present problems in patients taking more than one drug. Gabapentin and oxcarbazepine, by contrast, are relatively non-significant enzyme inducers, creating fewer drug interactions. Because anticonvulsant drugs may have more problematic side-effect profiles, their use should usually be deferred until antidepressant drugs have failed to relieve pain.

(a). Gabapentin (Neurontin)

(i). Description—structurally related to gamma aminobutyric acid (GABA) but does not interact with GABA receptors.

(ii). Indications—neuropathic pain.

(iii). Relative Contraindications—renal insufficiency.

iv. Dosing and Time to Therapeutic Effect—dosage may be increased over several days.

v. Major Side Effects—confusion, sedation.

vi. Drug Interactions—oral contraceptives, cimetidine, antacids.

vii. Recommended Laboratory Monitoring—renal function.

iii. Antidepressants are classified into a number of categories based on their chemical structure and their effects on neurotransmitter systems. Their effects on depression are attributed to their actions on disposition of norepinephrine and serotonin at the level of the synapse; although these synaptic actions are immediate, the symptomatic response in depression is delayed by several weeks. When used for chronic pain, the effects may in part arise from treatment of underlying depression, but may also involve additional neuromodulatory effects on endogenous opioid systems, raising pain thresholds at the level of the spinal cord.

(a). Pain responses may occur at lower drug doses with shorter times to symptomatic response than are observed when the same compounds are used in the treatment of mood disorders. Neuropathic pain, diabetic neuropathy, post-herpetic neuralgia, and cancer-related pain may respond to antidepressant doses low enough to avoid adverse effects that often complicate the treatment of depression.

(i). Tricyclics (e.g., amitriptyline [Elavil], nortriptyline [Pamelor, Aventyl], doxepin [Sinequan, Adapin])

[a]. Description—serotonergics, typically tricyclic antidepressants (TCAs), are utilized for their serotonergic properties as increasing CNS serotonergic tone can help decrease pain perception in non-antidepressant dosages. Amitriptyline is known for its ability to repair Stage 4 sleep architecture, a frequent problem found in chronic pain patients and to treat depression, frequently associated with chronic pain.

[b]. Indications—chronic musculoskeletal and/or neuropathic pain, insomnia. Second line drug treatment for depression.

[c]. Major Contraindications—cardiac disease or dysrhythmia, glaucoma, prostatic hypertrophy, seizures, suicide risk.

[d]. Dosing and Time to Therapeutic Effect—varies by specific tricyclic. Low dosages are commonly used for chronic pain and/or insomnia.

[e]. Major Side Effects—anticholinergic side effects including, but not limited to, dry mouth, sedation, orthostatic hypotension, cardiac arrhythmia, weight gain.

[f]. Drug Interactions—tramadol (may cause seizures), clonidine, cimetidine, sympathomimetics, valproic acid, warfarin, carbamazepine, bupropion, anticholinergics, quinolones.

[g]. Recommended Laboratory Monitoring—renal and hepatic function. Electrocardiogram (EKG) for those on high dosages or with cardiac risk.

iv. Minor tranquilizer/muscle relaxants are appropriate for muscle spasm, mild pain and sleep disorders.

(a). Optimum Duration—up to one week.

(b). Maximum Duration—four weeks.

v. Narcotics medications should be prescribed with strict time, quantity and duration guidelines, and with definitive cessation parameters. Adverse effects include respiratory depression, impaired alertness, and the development of physical and psychological dependence.

(a). Optimum Duration—up to seven days.

(b). Maximum Duration—two weeks. Use beyond two weeks is acceptable in appropriate cases, such as patients requiring complex surgical treatment.

vi. Nonsteroidal Anti-Inflammatory Drugs (NSAIDs) are useful for pain and inflammation. In mild cases, they may be the only drugs required for analgesia. There are several classes of NSAIDs, and the response of the individual injured worker to a specific medication is unpredictable. For this reason, a range of NSAIDs may be tried in each case with the most effective preparation being continued. Patients should be closely monitored for adverse reactions. The US Food and Drug Administration advises that many NSAIDs may cause an increased risk of serious cardiovascular thrombotic events, myocardial infarction, and stroke, which can be fatal. Naproxen sodium does not appear to be associated with increased risk of vascular events. Administration of proton pump inhibitors, Histamine 2 Blockers, or prostaglandin analog misoprostol along with these NSAIDs may reduce the risk of duodenal and gastric ulceration but do not impact possible cardiovascular complications. Due to the cross-reactivity between aspirin and NSAIDs, NSAIDs should not be used in aspirin-sensitive patients, and should be used with caution in all asthma patients. NSAIDs are associated with abnormal renal function, including renal failure, as well as, abnormal liver function. Certain NSAIDs may have interactions with various other medications. Individuals may have adverse events not listed above. Intervals for metabolic screening are dependent upon the patient's age, general health status and should be within parameters listed for each specific medication. Complete Blood Count (CBC), and liver and renal function should be monitored at least every six months in patients on chronic NSAIDs and initially when indicated.

(a). Non-selective Nonsteroidal Anti-Inflammatory Drugs

(i). Includes NSAIDs and acetylsalicylic acid (aspirin). Serious GI toxicity, such as bleeding, perforation, and ulceration can occur at any time, with or without warning symptoms in patients treated with traditional NSAIDs. Physicians should inform patients about the signs and/or symptoms of serious gastrointestinal toxicity and what steps to take if they occur. Anaphylactoid reactions may occur in patients taking NSAIDs. NSAIDs may interfere with platelet function. Fluid retention and edema have been observed in some patients taking NSAIDs.

[a]. Optimal Duration—one week.

[b]. Maximum Duration—one year. Use of these substances long-term (three days per week or greater) is associated with rebound pain upon cessation.

(b). Selective Cyclo-oxygenase-2 (COX-2) Inhibitors

(i). COX-2 inhibitors are more recent NSAIDs and differ in adverse side effect profiles from the traditional NSAIDs. The major advantages of selective COX-2 inhibitors over traditional NSAIDs are that they have less gastrointestinal toxicity and no platelet effects. COX-2 inhibitors can worsen renal function in patients with renal insufficiency, thus renal function may need monitoring.

(ii). COX-2 inhibitors should not be first-line for low risk patients who will be using an NSAID short-term but are indicated in select patients for whom traditional NSAIDs are not tolerated. Serious upper GI adverse events can occur even in asymptomatic patients. Patients at high risk for GI bleed include those who use alcohol, smoke, are older than 65, take corticosteroids or anti-coagulants, or have a longer duration of therapy. Celecoxib is contraindicated in sulfonamide allergic patients.

[a]. Optimal Duration—7 to 10 days.

[b]. Maximum Duration—chronic use is appropriate in individual cases. Use of these substances long-term (three days per week or greater) is associated with rebound pain upon cessation.

5. Occupational Rehabilitation Programs

a. Non-Interdisciplinary. These generally accepted programs are work-related, outcome-focused, individualized treatment programs. Objectives of the program include, but are not limited to, improvement of cardiopulmonary and neuromusculoskeletal functions (strength, endurance, movement, flexibility, stability, and motor control functions), patient education, and symptom relief. The goal is for patients to gain full or optimal function and return to work. The service may include the time-limited use of passive modalities with progression to achieve treatment and/or simulated/real work. These programs are frequently necessary for patients who must return to physically demanding job duties or whose injury requires prolonged rehabilitation and therapy spanning several months.

i. Work Conditioning. These programs are usually initiated once reconditioning has been completed but may be offered at any time throughout the recovery phase. It should be initiated when imminent return of a patient to modified or full duty is not an option, but the prognosis for returning the patient to work at completion of the program is at least fair to good.

(a). Length of Visit—one to two hours per day.

(b). Frequency—two to five visits per week.

(c). Optimum Duration—two to four weeks.

(d). Maximum Duration—six weeks. Participation in a program beyond six weeks must be documented with respect to need and the ability to facilitate positive symptomatic or functional gains.

ii. Work Simulation. Work Simulation is a program where an individual completes specific work-

related tasks for a particular job and return-to-work. Use of this program is appropriate when modified duty can only be partially accommodated in the work place, when modified duty in the work place is unavailable, or when the patient requires more structured supervision. The need for work place simulation should be based upon the results of a functional capacity evaluation and/or jobsite analysis.

(a). Length of Visit—two to six hours per day.

(b). Frequency—two to five visits per week.

(c). Optimum Duration—two to four weeks.

(d). Maximum Duration—six weeks. Participation in a program beyond six weeks must be documented with respect to need and the ability to facilitate positive symptomatic or functional gains.

b. Interdisciplinary programs are well-established treatment for patients with sub-acute and functionally impairing cervical spine pain. They are characterized by a variety of disciplines that participate in the assessment, planning, and/or implementation of an injured workers program with the goal for patients to gain full or optimal function and return to work. There should be close interaction and integration among the disciplines to ensure that all members of the team interact to achieve team goals. Programs should include cognitive-behavioral therapy as there is good evidence for its effectiveness in patients with chronic low back pain and it is probably effective in cervical spine pain. These programs are for patients with greater levels of disability, dysfunction, deconditioning and psychological involvement. For patients with chronic pain, refer to the *Chronic Pain Disorder Medical Treatment Guidelines*.

i. Work Hardening. Work hardening is an interdisciplinary program addressing a patient's employability and return to work. It includes a progressive increase in the number of hours per day that a patient completes work simulation tasks until the patient can tolerate a full workday. This is accomplished by addressing the medical, psychological, behavioral, physical, functional, and vocational components of employability and return-to-work.

(a). This can include a highly structured program involving a team approach or can involve any of the components thereof. The interdisciplinary team should, at a minimum, be comprised of a qualified medical director who is board certified with documented training in occupational rehabilitation; team physicians having experience in occupational rehabilitation; occupational therapy; physical therapy; case manager; and psychologist. As appropriate, the team may also include: chiropractor, RN, vocational specialist or certified biofeedback therapist.

(i). Length of Visit—up to eight hours/day.

(ii). Frequency—two to five visits per week.

(iii). Optimal Duration—two to four weeks.

(iv). Maximum Duration—six weeks. Participation in a program beyond six weeks must be documented with respect to need and the ability to facilitate positive symptomatic or functional gains.

6. Patient Education. No treatment plan is complete without addressing issues of individual and/or group patient education as a means of prolonging the beneficial effects of treatment, as well as facilitating self-management of symptoms and injury prevention. The patient should be encouraged to take an active role in the establishment of functional outcome goals. They should be educated on their specific injury, assessment findings, and plan of treatment. Instruction on breathing technique, proper body mechanics and posture, positions to avoid, self-care for exacerbation of symptoms, sleep postures, and home exercise should also be addressed. Patients with TOS may find that sleeping on the affected side, with the arms overhead or prone with head to one side can increase symptoms and should be avoided. Cervical roll pillows that do not result in overextension may be useful.

- a. Time to Produce Effect—varies with individual patient.
- b. Frequency—should occur at each visit.

7. Personality/Psychosocial/Psychiatric/Psychological Intervention. Psychosocial treatment is generally accepted, widely used, and well-established intervention. This group of therapeutic and diagnostic modalities includes, but is not limited to, individual counseling, group therapy, stress management, psychosocial crises intervention, hypnosis and meditation. Any evaluation or diagnostic workup should clarify and distinguish between pre-existing versus aggravated versus purely causative psychological conditions. Psychosocial intervention is recommended as an important component in the total management program that should be implemented as soon as the problem is identified. This can be used alone or in conjunction with other treatment modalities. Providers treating patients with chronic pain should refer to the OWCA's *Chronic Pain Disorder Medical Treatment Guidelines*.

- a. Time to Produce Effect—two to four weeks.
- b. Frequency—one to three times weekly for the first four weeks (excluding hospitalization, if required), decreasing to one to two times per week for the second month. Thereafter, two to four times monthly.
- c. Optimum Duration—six weeks to three months.
- d. Maximum Duration—3 to 12 months. Counseling is not intended to delay but to enhance functional recovery. For select patients, longer supervised treatment may be required and if further counseling beyond 3 months is indicated, extensive documentation addressing which pertinent issues are pre-existing versus aggravated versus causative, as well as projecting a realistic functional prognosis, should be provided by the authorized treating provider every 4 to 6 weeks during treatment.

8. Return-to-Work. Early return-to-work should be a prime goal in treating occupational injuries given the poor return-to-work prognosis for an injured worker who has been out of work for more than six months. It is imperative that the patient be educated regarding the benefits of return-to-work, work restrictions, and follow-up care if problems arise. When attempting to return a patient to work after a specific injury, clear objective restrictions of activity level should be made. An accurate job description with detailed physical duty restrictions may be necessary to assist the physician in making return-to-work recommendations. This may require a jobsite evaluation.

a. Employers should be prepared to offer transitional work. This may consist of temporary work in a less demanding position, return to the regular job with restrictions, or gradual return to the regular job. Company policies which encourage return-to-work with positive communication are most likely to have decreased worker disability.

b. *Return-to-Work*—any work or duty that the patient is able to perform safely. It may not be the patient's regular work. Due to the large spectrum of injuries of varying severity and varying physical demands in the work place, it is not possible to make specific return-to-work guidelines for each injury. Therefore, the OWCA recommends the following:

i. Establishment of a Return-to-Work Status. Ascertaining a return-to-work status is part of medical care, should be included in the treatment and rehabilitation plan, and addressed at every visit. A description of daily activity limitations is part of any treatment plan and should be the basis for restriction of work activities. In most non-surgical cases, the patient should be able to return-to-work in some capacity or in an alternate position consistent with medical treatment within several days unless there are extenuating circumstances. Injuries requiring more than two weeks off work should be thoroughly documented.

ii. Establishment of Activity Level Restrictions. Communication is essential between the patient, employer and provider to determine appropriate restrictions and return-to-work dates. It is the responsibility of the physician to provide clear concise restrictions, and it the employer's responsibility to determine if temporary duties can be provided within the restrictions. For treatment of TOS injuries, the following should be addressed when describing the patient's activity level:

- (a). activities such as overhead motion, lifting, abduction;
- (b). static neck and shoulder positions with regard to duration and frequency;
- (c). restriction of cervical hyperextension;
- (d). use of adaptive devices or equipment for proper ergonomics and to enhance capacities;
- (e). maximum Lifting limits with reference to the frequency of the lifting and/or the object height level;

- (f). maximum limits for pushing, pulling, with limits on bending and twisting at the waist as necessary; and
- (g). restrictions on ‘shoulder drooped’ or ‘head forward’ positions.

iii. Compliance with Activity Restrictions. In some cases, compliance with restriction of activity levels may require a complete jobsite evaluation, a functional capacity evaluation (FCE), or other special testing. Refer to the special tests section of this guideline.

9. Therapy-active. The following active therapies are widely used and accepted methods of care for a variety of work-related injuries. They are based on the philosophy that therapeutic exercise and/or activity are beneficial for restoring flexibility, strength, endurance, function, range of motion, and can alleviate discomfort. Active therapy requires physical effort by the individual to complete a specific exercise or task. This form of therapy requires supervision from a therapist or medical provider such as verbal, visual, and/or tactile instruction(s). At times, the provider may help stabilize the patient or guide the movement pattern but the energy required to complete the task is predominately executed by the patient.

a. Patients should be instructed to continue active therapies at home as an extension of the treatment process in order to maintain improvement levels. Follow-up visits to reinforce and monitor progress and proper technique are recommended. Home exercise can include exercise with or without mechanical assistance or resistance and functional activities with assistive devices.

b. The use of a patient completed pain drawing, Visual Analog Scale (VAS), is highly recommended to help providers track progress. Functional objective goals should be monitored and documented regularly to determine the effectiveness of treatment.

c. The following active therapies are listed in alphabetical order.

i. Activities of daily living (ADL) are well-established interventions which involve instruction, active-assisted training, and/or adaptation of activities or equipment to improve a person's capacity in normal daily activities such as self-care, work re-integration training, homemaking, and driving.

- (a). Time to Produce Effect—four to five treatments.
- (b). Frequency—three to five times per week.
- (c). Optimum Duration—four to six weeks.
- (d). Maximum Duration—six weeks.

ii. Aquatic therapy is a well-accepted treatment which consists of the therapeutic use of aquatic immersion for therapeutic exercise to promote range-of-motion, core stabilization, endurance, flexibility, strengthening, body mechanics, and pain management. Aquatic therapy includes the implementation of active therapeutic procedures in a swimming or therapeutic pool. The water provides a

buoyancy force that lessens the amount of force gravity applies to the body. The decreased gravity effect allows the patient to have a mechanical advantage and more likely have a successful trial of therapeutic exercise. Literature has shown that the muscle recruitment for aquatic therapy versus similar non-aquatic motions is significantly less. Because there is always a risk of recurrent or additional damage to the muscle tendon unit after a surgical repair, aquatic therapy may be preferred by surgeons to gain early return of range of motion. In some cases the patient will be able to do the exercises unsupervised after the initial supervised session. Parks and recreation contacts may be used to develop less expensive facilities for patients. Indications include:

(a). postoperative therapy as ordered by the surgeon; or Intolerance for active land-based or full-weight bearing therapeutic procedures; or

(b). symptoms that are exacerbated in a dry environment; and

(c). willingness to follow through with the therapy on a regular basis.

(i). The pool should be large enough to allow full extremity range of motion and fully erect posture. Aquatic vests, belts, snorkels, and other devices may be used to provide stability, balance, buoyancy, and resistance.

[a]. Time to Produce Effect—four to five treatments.

[b]. Frequency—three to five times per week.

[c]. Optimum Duration: Four to six weeks.

[d]. Maximum Duration: eight weeks

(ii). A self-directed program is recommended after the supervised aquatics program has been established, or, alternatively a transition to a self-directed dry environment exercise program.

(iii). Functional activities are well-established interventions which involve the use of therapeutic activity to enhance mobility, body mechanics, employability, coordination, balance, and sensory motor integration.

[a]. Time to Produce Effect—four to five treatments.

[b]. Frequency—three to five times per week.

[c]. Optimum Duration—four to six weeks.

[d]. Maximum Duration—six weeks.

(iv). Nerve Gliding is an accepted therapy for TOS. Nerve Gliding exercises consist of a series of gentle movements of the neck, shoulder and arm that produce longitudinal movement along the length of the nerves of the upper extremity. These exercises are based on the principle that the tissues of the peripheral nervous system are designed

for movement, and glide (excursion) of nerves may have an effect on neurophysiology through alterations in vascular and axoplasmic flow. Biomechanical principles have been more thoroughly studied than clinical outcomes. The exercises should be done by the patient after proper instruction and monitoring by the therapist.

- [a]. Time to Produce Effect—two to four weeks.
- [b]. Frequency—up to five times per day by patient (patient-initiated).
- [c]. Optimum Duration—four to six sessions.
- [d]. Maximum Duration—six to eight sessions.

(v). Neuromuscular re-education is a generally accepted treatment. Neuromuscular re-education is the skilled application of exercise with manual, mechanical, or electrical facilitation to enhance strength; movement patterns; neuromuscular response; proprioception, kinesthetic sense, coordination; education of movement, balance and posture. Indications include the need to promote neuromuscular responses through carefully timed proprioceptive stimuli to elicit and improve motor activity in patterns similar to normal neurologically developed sequences, and improve neuromotor response with independent

- [a]. Time to Produce Effect—two to six treatments.
- [b]. Frequency—three times per week.
- [c]. Optimum Duration—four to eight weeks.
- [d]. Maximum Duration—eight weeks.

(vi). Therapeutic exercise is a generally well-accepted treatment. Therapeutic exercise with or without mechanical assistance or resistance, may include isoinertial, isotonic, isometric and isokinetic types of exercises. The exact type of program and length of therapy should be determined by the treating physician with the physical or occupational therapist. In most cases the therapist instructs the patient in a supervised clinic and home program to increase motion and subsequently increase strength. Usually, isometrics are performed initially, progressing to isotonic exercises as tolerated.

- [a]. time to produce effect: two to six treatments;
  - [b]. frequency: two to three times per week;
  - [c]. optimum duration: 16 to 24 sessions;
  - [d]. maximum duration: 36 sessions.
- Additional visits may be necessary in cases of re-injury,

interrupted continuity of care, exacerbation of symptoms, and in those patients with comorbidities. Functional gains including increased range of motion must be demonstrated to justify continuing treatment.

10. Therapy—Passive. The following passive therapies and modalities are generally accepted methods of care for a variety of work-related injuries. Passive therapy includes those treatment modalities that do not require energy expenditure on the part of the patient. They are principally effective during the early phases of treatment and are directed at controlling symptoms such as pain, inflammation and swelling and to improve the rate of healing soft tissue injuries. They should be use adjunctively with active therapies such as postural stabilization and exercise programs to help control swelling, pain and inflammation during the rehabilitation process. Please refer to, General Guidelines Principles, Active Interventions. Passive therapies may be used intermittently as a therapist deems appropriate or regularly if there are specific goals with objectively measured functional improvements during treatment.

a. On occasion, specific diagnoses and post-surgical conditions may warrant durations of treatment beyond those listed as "maximum." Factors such as exacerbation of symptoms, re-injury, interrupted continuity of care, and comorbidities may also extend durations of care. Specific goals with objectively measured functional improvement during treatment must be cited to justify extended durations of care. It is recommended that, if no functional gain is observed after the number of treatments under "time to produce effect" has been completed, alternative treatment interventions, further diagnostic studies, or further consultations should be pursued.

b. The following passive therapies and modalities are listed in alphabetical order.

i. Electrical stimulation (unattended) is an accepted treatment. Once applied, electrical stimulation (unattended) requires minimal on-site supervision by the physical therapists, occupational therapist or other provider. Indications include pain, inflammation, muscle spasm, atrophy, decreased circulation, and the need for osteogenic stimulation. A home unit should be purchased if treatment is effective and frequent use is recommended.

- (a). Time to Produce Effect—two to four treatments.
- (b). Frequency—varies, depending upon indication, between two to three times/day to one time/week;
- (c). Optimum Duration—one to three months;
- (d). Maximum Duration—three months.

ii. Iontophoresis is an accepted treatment which consists of the transfer of medication, including, but not limited to, steroidal anti-inflammatories and anesthetics, through the use of electrical stimulation. Indications include pain (lidocaine), inflammation (hydrocortisone, salicylate), edema (mecholy, hyaluronidase, and salicylate), ischemia

(magnesium, mecholy, and iodine), muscle spasm (magnesium, calcium), calcifying deposits (acetate), scars, and keloids (sodium chloride, iodine, acetate).

(a). Time to Produce Effect—one to four treatments.

(b). Frequency—three times per week with at least 48 hours between treatments.

(c). Optimum Duration—8 to 10 treatments.

(d). Maximum Duration—10 treatments.

iii. Manipulation is a generally accepted treatment. Manipulative treatment (not therapy) is defined as the therapeutic application of manually guided forces by an operator to improve physiologic function and/or support homeostasis that has been altered by the injury or occupational disease, and has associated clinical significance.

(a). High velocity, low amplitude (HVLA) technique, chiropractic manipulation, osteopathic manipulation, muscle energy techniques, counter strain, and non-force techniques are all types of manipulative treatment. This may be applied by osteopathic physicians (D.O.), chiropractors (D.C.), properly trained physical therapists (P.T.), properly trained occupational therapists (O.T.), or properly trained medical physicians. Under these different types of manipulation exist many subsets of different techniques that can be described as direct- a forceful engagement of a restrictive/pathologic barrier; indirect- a gentle/non-forceful disengagement of a restrictive/pathologic barrier; the patient actively assisting in the treatment; and the patient relaxing, allowing the practitioner to move the body tissues. When the proper diagnosis is made and coupled with the appropriate technique, manipulation has no contraindications and can be applied to all tissues of the body. Pre-treatment assessment should be performed as part of each manipulative treatment visit to ensure that the correct diagnosis and correct treatment is employed.

(i). Time to Produce Effect for all Types of Manipulative Treatment—one to six treatments.

(ii). Frequency—up to three times per week for the first three weeks as indicated by the severity of involvement and the desired effect.

(iii). Optimum Duration—10 treatments.

(iv). Maximum Duration—12 treatments.

Additional visits may be necessary in cases of re-injury, interrupted continuity of care, exacerbation of symptoms, and in those patients with comorbidities. Functional gains including increased range of motion must be demonstrated to justify continuing treatment.

iv. Massage, manual or mechanical, is a generally well-accepted treatment. Massage is manipulation of soft tissue with broad ranging relaxation and circulatory benefits. This may include stimulation of acupuncture points and acupuncture channels (acupressure), application of suction

cups and techniques that include pressing, lifting, rubbing, pinching of soft tissues by, or with the practitioner's hands. Indications include edema (peripheral or hard and non-pliable edema), muscle spasm, adhesions, the need to improve peripheral circulation and range of motion, or to increase muscle relaxation and flexibility prior to exercise. In cases with edema, deep vein thrombosis should be ruled out prior to treatment.

(a). Time to Produce Effect—immediate.

(b). Frequency—one to two times per week.

(c). Optimum Duration—six weeks.

(d). Maximum Duration—two months.

v. Mobilization (joint) is a generally well-accepted treatment. Mobilization is passive movement, which may include passive range of motion performed in such a manner (particularly in relation to the speed of the movement) that it is, at all times, within the ability of the patient to prevent the movement if they so choose. It may include skilled manual joint tissue stretching. Indications include the need to improve joint play, improve intracapsular arthrokinematics, or reduce pain associated with tissue impingement.

(a). Time to Produce Effect—six to nine treatments.

(b). Frequency—three times per week.

(c). Optimum Duration—six weeks.

(d). Maximum Duration—two months.

vi. Mobilization (soft tissue) is a generally well-accepted treatment. Mobilization of soft tissue is the skilled application of muscle energy, strain/counter strain, myofascial release, manual trigger point release and manual therapy techniques designed to improve or normalize movement patterns through the reduction of soft tissue pain and restrictions. These can be interactive with the patient participating or can be with the patient relaxing and letting the practitioner move the body tissues. Indications include muscle spasm around a joint, trigger points, adhesions, and neural compression. Mobilization should be accompanied by active therapy.

(a). Time to Produce Effect—two to three weeks.

(b). Frequency—two to three times per week.

(c). Optimum Duration—four to six weeks.

(d). Maximum Duration—six weeks.

vii. Superficial heat and cold therapy is a generally accepted treatment. Superficial heat and cold therapies are thermal agents applied in various manners that lower or raise the body tissue temperature for the reduction of pain, inflammation, and/or effusion resulting from injury or induced by exercise. It may be used acutely with compression and elevation. Indications include acute pain, edema and hemorrhage, need to increase pain threshold, reduce muscle spasm and promote stretching/flexibility.

Includes portable cryotherapy units and application of heat just above the surface of the skin at acupuncture points.

- (a). Time to Produce Effect—immediate.
- (b). Frequency—two to five times per week.
- (c). Optimum Duration—three weeks as primary, or up to two months if used intermittently as an adjunct to other therapeutic procedures.
- (d). Maximum Duration—two months.

viii. Transcutaneous electrical nerve stimulation (TENS) is a generally accepted treatment and should include at least one instructional session for proper application and use. Indications include muscle spasm, atrophy, and decreased circulation and pain control. Minimal TENS unit parameters should include pulse rate, pulse width and amplitude modulation. Consistent, measurable functional improvement must be documented prior to the purchase of a home unit.

- (a). Time to Produce Effect—immediate.
- (b). Frequency—variable.
- (c). Optimum Duration—three sessions.
- (d). Maximum Duration—three sessions. If beneficial, provide with home unit or purchase if effective.

ix. Ultrasound (including phonophoresis) is an accepted treatment and includes ultrasound with electrical stimulation and phonophoresis. Ultrasound uses sonic generators to deliver acoustic energy for therapeutic thermal and/or non-thermal soft tissue effects. Indications include scar tissue, adhesions, collagen fiber and muscle spasm, and the need to extend muscle tissue or accelerate the soft tissue healing.

(a). Ultrasound with electrical stimulation is concurrent delivery of electrical energy that involves a dispersive electrode placement. Indications include muscle spasm, scar tissue, pain modulation, and muscle facilitation.

(b). Phonophoresis is the transfer of medication to the target tissue to control inflammation and pain through the use of sonic generators. These topical medications include, but are not limited to, steroidal anti-inflammatory and anesthetics.

- (i). Time to Produce Effect—6 to 15 treatments.
- (ii). Frequency—3 times per week.
- (iii). Optimum Duration—4 to 8 weeks.
- (iv). Maximum Duration—2 months.

11. Vocational rehabilitation is a generally accepted intervention. Initiation of vocational rehabilitation requires adequate evaluation of patients for quantification highest functional level, motivation and achievement of maximum medical improvement. Vocational rehabilitation may be as simple as returning to the original job or as complicated as being retrained for a new occupation.

a. It may also be beneficial for full vocational rehabilitation to be started before MMI if it is evident that the injured worker will be unable to return to his/her previous occupation. A positive goal and direction may aid the patient in decreasing stress and depression, and promote optimum rehabilitation.

AUTHORITY NOTE: Promulgated in accordance with R.S. 23:1203.1.

HISTORICAL NOTE: Promulgated by the Louisiana Workforce Commission, Office of Workers Compensation Administration, LR 37:1755 (June 2011).

**§2227. Therapeutic Procedures—Operative**

A. Operative treatment is indicated when the natural history of surgically treated lesions is better than the natural history for non-operatively treated lesions. All patients being considered for surgical intervention should first undergo a comprehensive neuro-musculoskeletal examination to identify mechanical pain generators that may respond to non-surgical techniques or may be refractory to surgical intervention.

1. Non-vascular Diagnostic Criteria for Surgical Procedures

a. True or Classic Neurogenic TOS

i. Clinical—at least two consistent clinical sign plus symptoms consistent with TOS (refer to initial diagnostic procedures).

ii. Neurophysiologic—meets criteria for neurogenic TOS (refer to follow-up diagnostic imaging and testing procedures).

b. Non-specific Neurogenic TOS (also called disputed)

i. Clinical—at least three consistent clinical signs plus symptoms consistent with TOS refer to discussion in Initial Diagnostic Procedures and alternative diagnoses have been explored and tests are negative.

ii. Neurophysiologic—may have normal EMG/NCV or a pattern not meeting criteria in EMG section.

c. Pectoralis Minor Syndrome without TOS

i. Compression of the Neurovascular Bundle by the Pectoralis Muscle. This syndrome, described by a few authors, is usually caused by neck or shoulder trauma and generally resolves with physical therapy.

ii. Clinical. Patients do not meet criteria for non-specific or true TOS. They generally have pain over the anterior chest wall near the pectoralis minor and into the axilla, arm, and forearm. They may complain of paresthesia or weakness, and have fewer complaints of headache, neck or shoulder pain. On physical exam there is tenderness with palpation over the pectoralis minor and in the axilla which reproduces the patient's symptoms in the arm. Disabling symptoms have been present for more than three months despite active participation in an appropriate therapy program and alternative diagnoses have been explored and tests are negative.



iii. Neurophysiologic and other Diagnostic Tests. EMG/NCV studies may show medial antebrachial cutaneous nerve changes compared to the normal side. The axillary vein may show some occlusion. Pectoralis minor block should be positive.

d. Non-surgical Diagnosis for Possible TOS

i. Clinical—inconsistent clinical signs plus symptoms of TOS for more than three months and alternative diagnoses have been explored and tests are negative.

ii. Neurophysiologic—may have normal EMG/NCV studies.

2. Surgical Indications

a. Early surgical intervention should be performed if there is:

i. documented EMG/NCV evidence of nerve compression with sensory loss, and weakness (with or without muscle atrophy); or

ii. acute subclavian vein thrombosis or arterial thrombosis; or

iii. subclavian artery aneurysm or stenosis secondary to a cervical or anomalous rib (Note: this condition is almost never work related.).

b. After failed conservative therapy, the following criteria must be fulfilled:

i. true neurogenic or non-specific TOS: see criteria in the preceding subsection; and

ii. a positive upper limb tension test; and

iii. failed three months of active participation in non-operative therapy including worksite changes; and

iv. disabling symptoms interfering with work, recreation, normal daily activities, sleep; and

v. pre-surgical psychiatric or psychological clearance has been obtained, demonstrating motivation and long-term commitment without major issues of secondary gain or other psychological contraindications for surgery, and with an expectation that surgical relief of pain probably would improve the patient's functioning.

c. Even if return to their prior job is unlikely, an individual may need surgical intervention to both increase activities-of-daily living and/or return-to-work in a different job.

d. It is critically important that all other pathology, especially shoulder disorders, be treated prior to surgical intervention for TOS.

e. Smoking may affect soft tissue healing through tissue hypoxia. Patients should be strongly encouraged to stop smoking and provided with appropriate counseling.

f. Prior to surgical intervention, the patient and treating physician should identify functional operative goals and the likelihood of achieving improved ability to perform

activities of daily living or work activities. The patient should agree to comply with the pre- and post-operative treatment plan including home exercise requirements. The patient should understand the amount of post operative therapy required and the length of partial and full disability expected post operatively.

3. Surgical Procedures

a. Since the success rates for the various surgical procedures are similar, the OWCA suggests that the surgeon performing the procedure use the technique with which the surgeon has the most experience and is most appropriate for the patient.

b. No controlled quality literature on surgical outcome for non-specific neurogenic TOS have been published. Uncontrolled case series suggest some improvement in symptoms in the majority of patients. In one study of workers' compensation patients operated on for TOS, work disability was reported to be 60 percent at one year. Other pathologies were commonly diagnosed in this population. Comorbid conditions of the shoulder, cervical spine, and carpal tunnel should be treated or ruled out before surgery is considered. Reported repeat surgery rates vary between approximately 10 percent and 30 percent. Some literature contends that patients with non-specific TOS treated conservatively have similar long-term outcomes as those treated with surgery. Complications and/or unsatisfactory outcomes are reportedly in the range of 15 to 20 percent. Acknowledged complications depend on the procedure and include complex regional pain syndrome; Horner's syndrome; permanent brachial plexus damage; phrenic, intercostal brachial cutaneous, or long thoracic nerve damage; and pneumothorax.

c. Vascular TOS procedures include resection of the abnormal rib and repair of the involved vessel. Anticoagulation is required for thrombotic cases.

i. first rib resection;

ii. anterior and middle scalenectomy;

iii. anterior scalenectomy;

iv. combined first rib resection and scalenectomy;

v. pectoralis minor tenotomy. This procedure is done under local anesthesia, normally in an out-patient setting for patients meeting the criteria for pectoralis minor syndrome.

4. Post-Operative Treatment

a. Individualized rehabilitation programs based upon communication between the surgeon and the therapist.

b. Generally, progressive resistive exercise no earlier than two months post-operatively with gradual return to full-activity at four to six months.

c. Return-to-work and restrictions after surgery may be made by an experienced primary occupational medicine physician in consultation with the surgeon or by the surgeon. Depending upon the patient's functional response and their

job requirements, return-to-work with job modifications may be considered as early as one week post operatively. The employer must be able to fully accommodate restrictions of overhead activities or heavy lifting. Work restrictions should be evaluated every four to six weeks during post-operative recovery and rehabilitation, with appropriate written communications to both the patient and the employer.

d. Should progress plateau, the provider should re-evaluate the patient's condition and make appropriate adjustments to the treatment plan.

e. Post-operative therapy will frequently require a repeat of the therapy provided pre-operatively. Refer to Therapeutic Procedures, Non-operative, and consider the first post-operative visit as visit number one for the time frame parameters provided.

f. Refer to the following areas in the non-operative therapeutic section for post-operative time parameters:

- i. activities of daily living;
- ii. functional activities;
- iii. nerve gliding;
- iv. neuromuscular re-education;
- v. therapeutic exercise;
- vi. proper work techniques. Refer to jobsite evaluation, and return-to-work, of these guidelines;
- vii. limited passive therapies may be appropriate in some cases.

AUTHORITY NOTE: Promulgated in accordance with R.S. 23:1203.1.

HISTORICAL NOTE: Promulgated by the Louisiana Workforce Commission, Office of Workers Compensation Administration, LR 37:1763 (June 2011).

## **Chapter 23. Upper and Lower Extremities Medical Treatment Guidelines**

### **Subchapter A. Lower Extremities**

Editor's Note: Form LWC-WC 1009. Disputed Claim for Medical Treatment has been moved to §2328 of this Part.

#### **§2301. Introduction**

A. This document has been prepared by the Louisiana Workforce Commission, Office of Workers' Compensation (OWCA) and should be interpreted within the context of guidelines for physicians/providers treating individuals qualifying under Louisiana's Workers' Compensation Act as injured workers with lower extremity injuries. Although the primary purpose of this document is advisory and educational, these guidelines are enforceable under the Louisiana Workers Compensation Act. All medical care, services, and treatment owed by the employer to the employee in accordance with the Louisiana Workers' Compensation Act shall mean care, services, and treatment in accordance with these guidelines. Medical Care, services, and treatment that varies from these guidelines shall also be

due by the employer when it is demonstrated to the medical director of the office by a preponderance of the scientific medical evidence, that a variance from these guidelines is reasonably required to cure or relieve the injured worker from the effects of the injury or occupational disease given the circumstances. Therefore, these guidelines are not relevant as evidence of a provider's legal standard of professional care. To properly utilize this document, the reader should not skip nor overlook any sections.

AUTHORITY NOTE: Promulgated in accordance with R.S. 23:1203.1.

HISTORICAL NOTE: Promulgated by the Louisiana Workforce Commission, Office of Workers Compensation Administration, LR 37:1765 (June 2011), amended LR 48:513 (March 2022).

#### **§2303. General Guidelines Principles**

A. The principles summarized in this section are key to the intended implementation of all Office of Workers' Compensation medical treatment guidelines and critical to the reader's application of the guidelines in this document.

1. Application of Guidelines. The OWCA provides procedures to implement medical treatment guidelines and to foster communication to resolve disputes among the provider, payer, and patient through the Workers' Compensation Act.

2. Education. Education of the patient and family, as well as the employer, insurer, policy makers and the community should be the primary emphasis in the treatment of workers' compensation injuries. Currently, practitioners often think of education last, after medications, manual therapy, and surgery. Practitioners must implement strategies to educate patients, employers, insurance systems, policy makers, and the community as a whole. An education-based paradigm should always start with inexpensive communication providing reassuring and evidence-based information to the patient. More in-depth education is currently a component of treatment regimens which employ functional restorative, preventive and rehabilitative programs. No treatment plan is complete without addressing issues of individual and/or group patient education as a means of facilitating self-management of symptoms and prevention. Facilitation through language interpretation, when necessary, is a priority and part of the medical care treatment protocol.

3. Informed Decision Making. Providers should implement informed decision making as a crucial element of a successful treatment plan. Patients, with the assistance of their health care practitioner, should identify their personal and professional functional goals of treatment at the first visit when a workers' compensation injury allows functional improvement. Progress towards the individual's identified functional goals should be addressed by all members of the health care team at subsequent visits and throughout the established treatment plan when a chronic pain condition allows attainment of functional goals. Injured workers may not reach functional goals to return to work and therefore they will require a significantly different plan. Nurse case managers, physical therapists, and other members of the

health care team play an integral role in informed decision-making and achievement of functional goals. Patient education and informed decision-making should facilitate self-management of symptoms and prevention of further injury.

4. Treatment Parameter Duration. Time frames for specific interventions commence once treatments have been initiated, not on the date of injury. Obviously, duration will be impacted by patient adherence, as well as availability of services. Clinical judgment may substantiate the need to accelerate or decelerate the time frames discussed in this document. Such deviation shall be in accordance with La. R.S. 23:1203.1

5. Active interventions emphasizing patient responsibility, such as therapeutic exercise and/or functional treatment, are generally emphasized over passive modalities, especially as treatment progresses. Generally, passive interventions are viewed as a means to facilitate progress in an active rehabilitation program with concomitant attainment of objective functional gains.

6. Active Therapeutic Exercise Program. Exercise program goals should incorporate patient strength, endurance, flexibility, coordination, and education. This includes functional application in vocational or community settings.

7. Positive Patient Response. Positive results are defined primarily as functional gains that can be objectively measured.

a. Objective functional gains include, but are not limited to, positional tolerances, range-of-motion (ROM), strength, and endurance, activities of daily living, ability to function at work, cognition, psychological behavior, and efficiency/velocity measures that can be quantified. Subjective reports of pain and function should be considered and given relative weight when the pain has anatomic and physiologic correlation. Anatomic correlation must be based on objective findings.

8. Re-Evaluation of Treatment Every Three to Four Weeks. If a given treatment or modality is not producing positive results within three to four weeks, the treatment should be either modified or discontinued. Reconsideration of diagnosis should also occur in the event of poor response to a seemingly rational intervention.

9. Surgical Interventions. Surgery should be contemplated within the context of expected functional outcome and not purely for the purpose of pain relief. The concept of "cure" with respect to surgical treatment by itself is generally a misnomer. All operative interventions must be based upon positive correlation of clinical findings, clinical course, and diagnostic tests. A comprehensive assimilation of these factors must lead to a specific diagnosis with positive identification of pathologic conditions.

10. Pharmacy-Louisiana Law and Regulation. All prescribing will be done in accordance with the laws of the state of Louisiana as they pertain respectively to each individual licensee, including, but not limited to: Louisiana

State Board of Medical Examiners regulations governing medications used in the treatment of non-cancer-related chronic or intractable pain; Louisiana Board of Pharmacy Prescription Monitoring Program; Louisiana Department of Health and Hospitals licensing and certification standards for pain management clinics; other laws and regulations affecting the prescribing and dispensing of medications in the state of Louisiana.

11. Six Month-Time Frame. Injuries resulting in temporary total disability require maintenance treatment and may not attain return to work in six months.

12. Return To Work. Return to work is therapeutic, assuming the work is not likely to aggravate the basic problem or increase long-term pain. An injured worker's return-to-work status shall not be the sole cause to deny reasonable and medically necessary treatment under these guidelines. Two good practices are: early contact with injured workers and provide modified work positions for short-term injuries. The practitioner may provide specific physical limitations and the patient should never be released to non-specific and vague descriptions such as "sedentary" or "light duty." The following physical limitations should be considered and modified as recommended: lifting, pushing, pulling, crouching, walking, using stairs, bending at the waist, awkward and/or sustained postures, tolerance for sitting or standing, hot and cold environments, data entry and other repetitive motion tasks, sustained grip, tool usage and vibration factors. Even if there is residual chronic pain, return-to-work is not necessarily contraindicated. The practitioner should understand all of the physical demands of the patient's job position before returning the patient to full duty and should request clarification of the patient's job duties. Clarification should be obtained from the employer or, if necessary, from including, but not limited to, occupational health nurse, physical therapist, occupational therapist, vocational rehabilitation specialist, an industrial hygienist, chiropractor or another professional. American Medical Association clarifies "disability" as "activity limitations and/or participation restrictions in an individual with a health condition, disorder or disease" versus "impairment" as "a significant deviation, loss, or loss of use of any body structure or body function in an individual with a health condition, disorder or disease".

13. Delayed Recovery. Within the discretion of the treating physician, strongly consider a psychological evaluation, if not previously provided, as well as initiating interdisciplinary rehabilitation treatment and vocational goal setting, for those patients who are failing to make expected progress 6 to 12 weeks after initiation of treatment of an injury. The OWCA recognizes that 3 to 10 percent of all industrially injured patients will not recover within the timelines outlined in this document despite optimal care. Such individuals may require treatments beyond the limits discussed within this document, but such treatment requires clear documentation by the authorized treating practitioner focusing on objective functional gains afforded by further treatment and impact upon prognosis.

14. Guideline Recommendations and Inclusion of Medical Evidence. Guidelines are recommendations based on available evidence and/or consensus recommendations. When possible, guideline recommendations will note the level of evidence supporting the treatment recommendation. When interpreting medical evidence statements in the guideline, the following apply to the strength of recommendation.

Strong	Level 1 Evidence	We Recommend
Moderate	Level 2 and Level 3 Evidence	We Suggest
Weak	Level 4 Evidence	Treatment is an Option
Inconclusive	Evidence is Either Insufficient or Conflicting	

a. Consensus guidelines are generated by a professional organization that the guidelines are intended to serve. A committee of specialists and experts are selected by the organization to create an unbiased, vetted recommendation for the treatment of specific issues within the realm of their expertise. All recommendations in the guideline are considered to represent reasonable care in appropriately selected cases, regardless of the level of evidence or consensus statement attached to it. Those procedures considered inappropriate, unreasonable, or unnecessary are designated in the guideline as “not recommended.”

15.a. Treatment of Pre-Existing Conditions The conditions that preexisted the work injury/disease will need to be managed under two circumstances:

i. a pre-existing condition exacerbated by a work injury/disease should be treated until the patient has returned to their objectively verified prior level of functioning or Maximum Medical Improvement (MMI); and

ii. a pre-existing condition not directly caused by a work injury/disease but which may prevent recovery from that injury should be treated until its objectively verified negative impact has been controlled.

b. The focus of treatment should remain on the work injury/disease.

B. The remainder of this document should be interpreted within the parameters of these guideline principles that may lead to more optimal medical and functional outcomes for injured workers.

AUTHORITY NOTE: Promulgated in accordance with R.S. 23:1203.1.

HISTORICAL NOTE: Promulgated by the Louisiana Workforce Commission, Office of Workers Compensation Administration, LR 37:1765 (June 2011), amended by the Louisiana Workforce Commission, Office of Workers Compensation, LR 40:1160 (June 2014), LR 48:513 (March 2022).

**§2305. Initial Diagnostic Procedures**

A. The OWCA recommends the following diagnostic procedures be considered, at least initially, the responsibility of the workers’ compensation carrier to ensure that an accurate diagnosis and treatment plan can be established. Standard procedures that should be utilized when initially

diagnosing a work-related lower extremity complaint are listed below.

1. History-taking and physical examination (Hx & PE) are generally accepted, well-established and widely used procedures that establish the foundation/basis for and dictates subsequent stages of diagnostic and therapeutic procedures. When findings of clinical evaluations and those of other diagnostic procedures are not complementing each other, the objective clinical findings should have preference. The medical records should reasonably document the following:

a. History of Present Injury

i. Mechanism of injury. This includes details of symptom onset and progression. It should include such details as: the activity at the time of the injury, patient description of the incident, and immediate and delayed symptoms. The history should elicit as much detail about these mechanisms as possible.

ii. Relationship to work. This includes a statement of the probability that the illness or injury is work-related.

iii. History of locking, clicking, popping, giving way, acute or chronic swelling, crepitation, pain while ascending or descending stairs (e.g. handrail used, ‘foot by foot’ instead of ‘foot over foot’) inability to weight bear due to pain, intolerance for standing or difficulty walking distances on varied surfaces, difficulty crouching or stooping, and wear patterns on footwear. Patients may also report instability or mechanical symptoms.

iv. Any history of pain in back as well as joints distal and proximal to the site of injury. The use of a patient completed pain drawing, Visual Analog Scale (VAS), is highly recommended, especially during the first two weeks following injury to assure that all work related symptoms are addressed.

v. Ability to perform job duties and activities of daily living; and

vi. Exacerbating and alleviating factors of the reported symptoms. The physician should explore and report on non-work related as well as, work related activities.

vii. Prior occupational and non-occupational injuries to the same area including specific prior treatment and any prior bracing devices.

viii. Discussion of any symptoms present in the uninjured extremity.

ix. Lower extremity injuries are frequently not isolated, but are accompanied by other injuries. In the setting of a traumatic brain injury (TBI), long bone fracture management must consider the effect of TBI on bone metabolism and may require more aggressive treatment. Refer to the Traumatic Brain Injury Medical Treatment Guidelines, Musculoskeletal Complications.

b. Past History

i. past medical history includes neoplasm, gout, arthritis, previous musculoskeletal injuries, and diabetes;

ii. review of systems includes symptoms of rheumatologic, neurological, endocrine, neoplastic, and other systemic diseases;

iii. History of smoking, alcohol use, and substance abuse;

iv. History of corticosteroid use; and

v. vocational and recreational pursuits.

c. Physical Examination: Examination of a joint should begin with examination of the uninjured limb and include assessment of the joint above and below the affected area of the injured limb. Physical examinations should include accepted tests as described in textbooks or other references and exam techniques applicable to the joint or region of the body being examined, including:

i. Visual inspection; Swelling: may indicate joint effusion from trauma, infection or arthritis. Swelling or bruising over ligaments or bones can indicate possible fractures or ligament damage;

ii. Palpation: for joint line tenderness, effusion, and bone or ligament pain. Palpation may be used to assess tissue tone and contour; myofascial trigger points; and may be graded for intensity of pain. Palpation may be further divided into static and motion palpation. Static palpation consists of feeling bony landmarks and soft tissue structures and consistency. Motion palpation is commonly used to assess joint movement patterns and identify joint dysfunction;

iii. Assessment of activities of daily living including gait abnormalities, especially after ambulating a distance and difficulties ascending/descending stairs; Assessment of activities such as the inability to crouch or stoop, may give important indications of the patient's pathology and restrictions;

iv. range-of-motion/quality-of-motion; should be assessed actively and passively;

v. strength;

vi. joint stability;

vii. Hip exam: In general multiple tests are needed to reliably establish a clinical diagnosis. Spinal pathology and groin problems should always be considered and ruled out as a cause of pain for patients with hip symptomatology. The following is a list of commonly performed tests;

(a). Flexion-Abduction-External Rotation (FABER-aka Patrick's) test - is frequently used as a test for sacral pathology;

(b). Log roll test - may be used to assess iliofemoral joint laxity;

(c). Ober's is used to test the iliotibial band;

(d). Greater trochanter bursitis is aggravated by external rotation and adduction and resisted hip abduction or external rotation;

(e). Iliopectineal bursitis may be aggravated by stretching the tendon in hip extension;

(f). Internal and external rotation is usually painful in osteoarthritis;

(g). The maneuvers of flexion, adduction and internal rotation (FADIR) will generally reproduce pain in cases of labral tears and with piriformis strain/irritation.

viii. Knee exam: In general multiple tests are needed to reliably establish a clinical diagnosis. The expertise of the physician performing the exam influences the predictability of the exam findings. Providers should be aware that patients with osteoarthritis may have positive pain complaints with various maneuvers based on their osteoarthritis rather than ligamentous or meniscal damage. The following is a partial list of commonly performed tests.

(a). Bilateral thigh circumference measurement: assesses for quadriceps wasting which may occur soon after a knee injury. The circumferences of both thighs should be documented approximately 15 cm above a reference point, either the joint line or patella.

(b). Anterior Cruciate Ligament tests:

(i). Lachman's test;

(ii). Anterior drawer test;

(iii).Lateral pivot shift test.

(c). Meniscus tests. Joint line tenderness and effusions are common with acute meniscal tears. Degenerative meniscal tears are fairly common in older patients with degenerative changes and may be asymptomatic.

(i). McMurray test;

(ii). Apley compression test;

(iii).Medial lateral grind test;

(iv).Weight-bearing tests - include Thessaly and Ege's test.

(d). Posterior Cruciate Ligament tests:

(i). Posterior drawer test;

(ii). Extension lag may also be measured passively by documenting the heel height difference with the patient prone.

(e). Collateral Ligaments tests:

(i). Medial stress test – A positive test in full extension may include both medial collateral ligament and cruciate ligament pathology;

(ii). Lateral stress test.

(f). Patellar Instability tests:

- (i). Apprehension test;
- (ii). J sign;
- (iii). Q angle.

ix. Foot and ankle exam: In general multiple tests are needed to reliably establish a clinical diagnosis. The expertise of the physician performing the exam influences the predictability of the exam findings. Ankle assessments may include anterior drawer exam, talar tilt test, external rotation stress test, ankle ligament stress test and the tibia-fibula squeeze test. Achilles tendon may be assessed with the Thompson's test. Foot examinations may include, assessment of or for: subtalar, midtarsal, and metatarsal-phalangeal joints; tarsal tunnel; and posterior tibial tendon; Morton's neuroma; the piano key test and Lisfranc injury.

x. If applicable, full neurological exam including muscle atrophy and gait abnormality.

xi. If applicable to injury, integrity of distal circulation, sensory, and motor function.

2. Radiographic imaging of the lower extremities is a generally accepted, well-established and widely used diagnostic procedure when specific indications based on history and/or physical examination are present. It should not be routinely performed. The mechanism of injury and specific indications for the radiograph should be listed on the request form to aid the radiologist and x-ray technician. For additional specific clinical indications, refer to "Specific Lower Extremity Injury Diagnosis, Testing and Treatment." Indications for initial imaging include any of the following:

a. The inability to flex knee to 90 degrees or to transfer weight for four steps at the time of the immediate injury and at the initial visit, regardless of limping;

b. Bony tenderness on any of the following areas: over the head of the fibula; isolated to the patella; of the lateral or medial malleolus from the tip to the distal 6 cm; at the base of the 5th metatarsal; or at the navicular;

c. History of significant trauma, especially blunt trauma or fall from a height;

d. Age over 55 years;

e. History or exam suggestive of intravenous drug abuse or osteomyelitis;

f. Pain with swelling and/or range of motion (ROM) limitation localizing to an area of prior fracture, internal fixation, or joint prosthesis; or

g. Unexplained or persistent lower extremity pain over two weeks.

i. Occult fractures, especially stress fractures, may not be visible on initial x-ray. A follow-up radiograph, MRI and/or bone scan may be required to make the diagnosis.

ii. Weight-bearing radiographs are used to assess osteoarthritis and alignment prior to some surgical procedures.

3. Laboratory testing. Laboratory tests are generally accepted, well-established and widely used procedures. They are, however, rarely indicated at the time of initial evaluation, unless there is suspicion of systemic illness, infection, neoplasia, connective tissue disorder, or underlying arthritis or rheumatologic disorder based on history and/or physical examination. Laboratory tests can provide useful diagnostic information. The OWCA recommends that lab diagnostic procedures be initially considered the responsibility of the workers' compensation carrier to ensure that an accurate diagnosis and treatment plan can be established. Tests include, but are not limited to:

a. Complete blood count (CBC) with differential can detect infection, blood dyscrasias, and medication side effects;

b. Erythrocyte sedimentation rate, rheumatoid factor, antinuclear antigen (ANA), human leukocyte antigen (HLA), and C-reactive protein (CRP) can be used to detect evidence of a rheumatologic, infection, or connective tissue disorder;

c. Serum calcium, phosphorous, uric acid, alkaline phosphatase, and acid phosphatase can detect metabolic bone disease;

d. Liver and kidney function may be performed for prolonged anti-inflammatory use or other medications requiring monitoring; and

e. Analysis of joint aspiration for bacteria, white cell count, red cell count, fat globules, crystalline birefringence and chemistry to evaluate joint effusion.

#### 4. Other procedures

a. Joint Aspiration is a generally accepted, well-established and widely used procedure when specifically indicated and performed by individuals properly trained in these techniques. This is true at the initial evaluation when history and/or physical examination are of concern for a septic joint or bursitis and for some acute injuries. Particularly at the knee, aspiration of a large effusion can help to decrease pain and speed functional recovery. Persistent or unexplained effusions may be examined for evidence of infection, rheumatologic, or inflammatory processes. The presence of fat globules in the effusion strongly suggests occult fracture.

i. Risk factors for septic arthritis include joint surgery, knee arthritis, joint replacement, skin infection, diabetes, age greater than 80, immunocompromised states, and rheumatoid arthritis. More than 50 percent of patients with septic joints have a fever greater than 37.5 degrees centigrade and joint swelling. Synovial white counts of greater than 25,000 and polymorphonuclear cells of at least 90 percent increase the likelihood of a septic joint.

AUTHORITY NOTE: Promulgated in accordance with R.S. 23:1203.1.

HISTORICAL NOTE: Promulgated by the Louisiana Workforce Commission, Office of Workers Compensation Administration, LR 37:1767 (June 2011).

### §2307. Follow-Up Diagnostic Imaging and Testing Procedures

A. One diagnostic imaging procedure may provide the same or distinctive information as obtained by other procedures. Therefore, prudent choice of procedure(s) for a single diagnostic procedure, a complementary procedure in combination with other procedures(s), or a proper sequential order in multiple procedures will ensure maximum diagnostic accuracy; minimize adverse effect to patients and cost effectiveness by avoiding duplication or redundancy.

B. All diagnostic imaging procedures have a significant percentage of specificity and sensitivity for various diagnoses. None is specifically characteristic of a certain diagnosis. Clinical information obtained by history taking and physical examination should be the basis for selection and interpretation of imaging procedure results.

C. When a diagnostic procedure, in conjunction with clinical information, provides sufficient information to establish an accurate diagnosis, the second diagnostic procedure will become a redundant procedure. At the same time, a subsequent diagnostic procedure can be a complementary diagnostic procedure if the first or preceding procedures, in conjunction with clinical information, cannot provide an accurate diagnosis. Usually, preference of a procedure over others depends upon availability, a patient's tolerance, and/or the treating practitioner's familiarity with the procedure.

1. Imaging Studies. When indicated, the following additional imaging studies can be utilized for further evaluation of the lower extremity, based upon the mechanism of injury, symptoms, and patient history. For specific clinical indications, see Section E, Specific Lower Extremity Injury Diagnosis, Testing, and Treatment. The studies below are listed in frequency of use, not importance.

a. Magnetic Resonance Imaging (MRI) are generally accepted, well-established, and widely used diagnostic procedures. It provides a more definitive visualization of soft tissue structures, including ligaments, tendons, joint capsule, menisci and joint cartilage structures, than x-ray or Computed Axial Tomography in the evaluation of traumatic or degenerative injuries. The addition of intravenous or intra-articular contrast can enhance definition of selected pathologies.

i. The high field, closed MRI with 1.5 or higher tesla provides better resolution. A lower field scan may be indicated when a patient cannot fit into a high field scanner or is too claustrophobic despite sedation. Inadequate resolution on the first scan may require a second MRI using a different technique or with a reading by a musculoskeletal radiologist. All questions in this regard should be discussed with the MRI center and/or radiologist.

ii. MRIs have high sensitivity and specificity for meniscal tears and ligamentous injuries although in some cases when physical exam findings and functional deficits indicate the need for surgery an MRI may not be necessary. MRI is less accurate for articular cartilage defects

(sensitivity 76 percent) than for meniscal and ligamentous injury (sensitivity greater than 90 percent).

iii. MRIs have not been shown to be reliable for diagnosing symptomatic hip bursitis.

b. MR Arthrography (MRA): This accepted investigation uses the paramagnetic properties of gadolinium to shorten T1 relaxation times and provide a more intense MRI signal. It should be used to diagnose hip labral tears. Pelvic MRIs are not sufficient for this purpose. Arthrograms are also useful to evaluate mechanical pathology in knees with prior injuries and/or surgery.

c. Computed Axial Tomography (CT) is generally accepted and provides excellent visualization of bone. It is used to further evaluate bony masses and suspected fractures not clearly identified on radiographic window evaluation. Instrument scatter-reduction software provides better resolution when metallic artifact is of concern.

d. Diagnostic Sonography is an accepted diagnostic procedure. The performance of sonography is operator-dependent, and is best when done by a specialist in musculoskeletal radiology. It may also be useful for post-operative pain after total knee arthroplasty (TKA), and for dynamic testing especially of the foot or ankle.

e. Lineal Tomography is infrequently used, yet may be helpful in the evaluation of joint surfaces and bone healing.

f. Bone Scan (Radioisotope Bone Scanning) is generally accepted, well-established and widely used. <sup>99m</sup>TcTechnecium diphosphonate uptake reflects osteoblastic activity and may be useful in metastatic/primary bone tumors, stress fractures, osteomyelitis, and inflammatory lesions, but cannot distinguish between these entities.

i. Bone scanning is more sensitive but less specific than MRI. It is useful for the investigation of trauma, infection, stress fracture, occult fracture, Charcot joint, Complex Regional Pain Syndrome and suspected neoplastic conditions of the lower extremity.

g. Other Radionuclide Scanning: Indium and gallium scans are generally accepted, well-established, and widely used procedures usually to help diagnose lesions seen on other diagnostic imaging studies. <sup>67</sup>Gallium citrate scans are used to localize tumor, infection, and abscesses. <sup>111</sup>Indium-labeled leukocyte scanning is utilized for localization of infection or inflammation.

h. Arthrogram is an accepted diagnostic procedure. It may be useful in the evaluation of internal derangement of a joint, including when MRI or other tests are contraindicated or not available. Potential complications of this more invasive technique include pain, infection, and allergic reaction. Arthrography gains additional sensitivity when combined with CT in the evaluation of internal derangement, loose bodies, and articular cartilage surface lesions. Diagnostic arthroscopy should be considered before arthrogram when there are strong clinical indications.

2. Other Diagnostic Tests. The following diagnostic procedures listed in this subsection are listed in alphabetical order.

a. Compartment Pressure Testing and Measurement Devices: such as pressure manometer, are useful in the evaluation of patients who present symptoms consistent with a compartment syndrome.

b. Diagnostic Arthroscopy (DA) allows direct visualization of the interior of a joint, enabling the diagnosis of conditions when other diagnostic tests have failed to reveal an accurate diagnosis; however, it should generally not be employed for exploration purposes only. In order to perform a diagnostic arthroscopy, the patient must have completed at least some conservative therapy without sufficient functional recovery per Section E, Specific Lower Extremity Injury Diagnosis, Testing, and Treatment, and meet criteria for arthroscopic repair.

i. DA may also be employed in the treatment of acute joint disorders. In some cases, the mechanism of injury and physical examination findings will strongly suggest the presence of a surgical lesion. In those cases, it is appropriate to proceed directly with the interventional arthroscopy.

c. Doppler ultrasonography/plethysmography is useful in establishing the diagnosis of arterial and venous disease in the lower extremity and should usually be considered prior to the more invasive venogram or arteriogram study. Doppler is less sensitive in detecting deep vein thrombosis in the calf muscle area. If the test is initially negative and symptoms continue, an ultrasound should usually be repeated seven days later to rule out popliteal thrombosis. It is also useful for the diagnosis of popliteal mass when MRI is not available or contraindicated.

d. Electrodiagnostic Testing. Electrodiagnostic tests include, but are not limited to Electromyography (EMG), Nerve Conduction Studies (NCS) and Somatosensory Evoked Potentials (SSEP). These are generally accepted, well-established and widely used diagnostic procedures. The SSEP study, although generally accepted, has limited use. Electrodiagnostic studies may be useful in the evaluation of patients with suspected involvement of the neuromuscular system, including disorder of the anterior horn cell, radiculopathies, peripheral nerve entrapments, peripheral neuropathies, neuromuscular junction and primary muscle disease.

i. In general, these diagnostic procedures are complementary to imaging procedures such as CT, MRI, and/or myelography or diagnostic injection procedures. Electrodiagnostic studies may provide useful, correlative neuropathophysiological information that would be otherwise unobtainable from standard radiologic studies.

e. Personality/Psychological/Psychiatric/Psychosocial Evaluations

i. Formal psychological or psychosocial evaluation should be performed on patients not making expected progress within 6 to 12 weeks following injury and whose subjective symptoms do not correlate with objective

signs and test results. In addition to the customary initial exam, the evaluation of the injured worker should specifically address the following areas:

- (a). employment history;
- (b). interpersonal relationships-both social and work;
- (c). patient activities;
- (d). current perception of the medical system;
- (e). current perception/attitudes toward employer/job;
- (f). results of current treatment;
- (g). risk factors and psychological comorbidities that may influence outcome and that may require treatment.

(h). Childhood history, including history of childhood psychological trauma, abuse and family history of disability.

ii. Personality/psychological/psychosocial evaluations consist of two components, clinical interview and psychological testing. Results should help clinicians with a better understanding of the patient in a number of ways. Thus the evaluation result will determine the need for further psychosocial interventions; and in those cases, Diagnostic and Statistical Manual of Mental Disorders (DSM) diagnosis should be determined and documented. The evaluation should also include examination of both psychological comorbidities and psychological risk factors that are empirically associated with poor outcome and/or delayed recovery. An individual with a Ph.D., Psy.D, or psychiatric M.D./D.O. credentials should perform initial evaluations, which are generally completed within one to two hours. A professional fluent in the primary language of the patient is preferred. When such a provider is not available, services of a professional language interpreter should be provided.

(a). Frequency. one-time visit for the clinical interview. If psychometric testing is indicated as a part of the initial evaluation, time for such testing shall be allotted at least, six hours of professional time or whatever is deemed appropriate by the health care professional.

f. Venogram/Arteriogram is useful for investigation of vascular injuries or disease, including deep venous thrombosis. Potential complications may include pain, allergic reaction, and deep vein thrombosis.

3. Special tests are generally well-accepted tests and are performed as part of a skilled assessment of the patient's capacity to return-to-work, his/her strength capacities, and physical work demand classifications and tolerances. The procedures in this subsection are listed in alphabetical order.

a. Computer-Enhanced Evaluations may include isotonic, isometric, isokinetic and/or isoinertial measurement of movement, range of motion, balance, endurance or strength. Values obtained can include degrees of motion, torque forces, pressures or resistance. Indications include



determining validity of effort, effectiveness of treatment and demonstrated motivation. These evaluations should not be used alone to determine return-to-work restrictions.

i. Frequency: One time for evaluation. Can monitor improvements in strength every three to four weeks up to a total of six evaluations.

b. Functional Capacity Evaluation (FCE) is a comprehensive or modified evaluation of the various aspects of function as they relate to the worker's ability to return-to-work. Areas such as endurance, lifting (dynamic and static), postural tolerance, specific range of motion, coordination and strength, worker habits, employability, as well as psychosocial aspects of competitive employment may be evaluated. Components of this evaluation may include: musculoskeletal screen; cardiovascular profile/aerobic capacity; coordination; lift/carrying analysis; job-specific activity tolerance; maximum voluntary effort; pain assessment/psychological screening; and non-material and material handling activities.

i. When an FCE is being used to determine return to a specific jobsite, the provider is responsible for fully understanding the job duties. A jobsite evaluation is frequently necessary. FCEs cannot be used in isolation to determine work restrictions. The authorized treating physician must interpret the FCE in light of the individual patient's presentation and medical and personal perceptions. FCEs should not be used as the sole criteria to diagnose malingering. Full FCEs are sometimes necessary. In many cases, a work tolerance screening will identify the ability to perform the necessary job tasks. FCEs are not necessary to assign permanent impairment ratings in the Colorado workers' compensation system. If Partial FCEs are performed, it is recognized that all parts of the FCE that are not performed are considered normal.

(a). Frequency: Can be used initially to determine baseline status; and for case closure when patient is unable to return to pre-injury position and further information is desired to determine permanent work restrictions. Prior authorization is required for FCEs performed during treatment.

c. Jobsite Evaluation is a comprehensive analysis of the physical, mental and sensory components of a specific job. These components may include, but are not limited to: postural tolerance (static and dynamic); aerobic requirements; range of motion; torque/force; lifting/carrying; cognitive demands; social interactions; visual perceptual; sensation; coordination; environmental requirements of a job; repetitiveness; and essential job functions including job licensing requirements. Job descriptions provided by the employer are helpful but should not be used as a substitute for direct observation.

i. A jobsite evaluation may include observation and instruction of how work is done, what material changes (desk, chair) should be made, and determination of readiness to return to work.

(a). Requests for a jobsite evaluation should describe the expected goals for the evaluation. Goals may include, but are not limited to the following:

(i). To determine if there are potential contributing factors to the person's condition and/or for the physician to assess causality;

(ii). To make recommendations for, and to assess the potential for ergonomic changes;

(iii). To provide a detailed description of the physical and cognitive job requirements;

(iv). To assist the patient in their return to work by educating them on how they may be able to do their job more safely in a bio-mechanically appropriate manner; and/or

(v). To give detailed work/activity restrictions.

[a]. Frequency: One time with additional visits as needed for follow-up visits per jobsite.

d. Vocational Assessment: The vocational assessment should provide valuable guidance in the determination of future rehabilitation program goals. It should clarify rehabilitation goals, which optimize both patient motivation and utilization of rehabilitation resources. If prognosis for return to former occupation is determined to be poor, except in the most extenuating circumstances, vocational assessment should be implemented within 3 to 12 months post-injury. Declaration of MMI should not be delayed solely due to lack of attainment of a vocational assessment.

i. Frequency: One time with additional visits as needed for follow-up

e. Work Tolerance Screening (Fitness for Duty) is a determination of an individual's tolerance for performing a specific job based on a job activity or task. It may include a test or procedure to specifically identify and quantify work-relevant cardiovascular, physical fitness and postural tolerance. It may also address ergonomic issues affecting the patient's return-to-work potential. May be used when a full FCE is not indicated.

i. Frequency: One time for initial screen. May monitor improvements in strength every three to four weeks up to a total of six visits.

AUTHORITY NOTE: Promulgated in accordance with R.S. 23:1203.1.

HISTORICAL NOTE: Promulgated by the Louisiana Workforce Commission, Office of Workers Compensation Administration, LR 37:1769 (June 2011), amended LR 48:515 (March 2022).

**§2309. Specific Lower Extremity Injury Diagnosis, Testing, and Treatment**

A. There are three main areas.

1. Foot and Ankle

a. Achilles Tendonopathy/or Injury and Rupture (ALTERNATE SPELLING: "TENDINOPATHY"):

i. Description/Definition: Rupture or tear of Achilles tendon or insertional or non-insertional tendonopathy.

ii. Occupational Relationship: Tears or ruptures are related to a fall, twisting, jumping, or sudden load on ankle with dorsiflexion. Tendonopathy may be exacerbated by continually walking on hard surfaces.

iii. Specific Physical Exam Findings: Swelling and pain at tendon, sometimes accompanied by crepitus and pain with passive motion. Rupture or partial tear may present with palpable deficit in tendon. If there is a full tear, Thompson test will usually be positive. A positive Thompson's test is lack of plantar flexion with compression of the calf when the patient is prone with the knee flexed.

iv. Diagnostic Testing Procedures: Radiography may be performed to identify Haglund's deformity; however, many Haglund's deformities are asymptomatic. MRI or ultrasound may be performed if surgery is being considered for tendonopathy or rupture.

v. Non-operative Treatment Procedures:

(a). Initial Treatment: Cast in non weight-bearing for tears. Protected weight-bearing for other injuries.

(b). Medications such as analgesics and anti-inflammatories may be helpful. Refer to medication discussions in Medications and Medical Management.

(c). Patient education should include instruction in self-management techniques, ergonomics, body mechanics, home exercise, joint protection, and weight management.

(d). Benefits may be achieved through therapeutic rehabilitation and rehabilitation interventions. Eccentric training alone or with specific bracing may be used for tendonopathy. Manual therapy may also be used. Therapy will usually include range-of-motion (ROM), active therapies, and a home exercise program. Active therapies include, proprioception training, restoring normal joint mechanics, and clearing dysfunctions from adjacent structures. Passive as well as active therapies may be used for control of pain and swelling. Therapy should progress to strengthening and an independent home exercise program targeted to further improve ROM, strength, and normal joint mechanics influenced by distal and proximal structures. Refer to Therapeutic Procedures, Non-operative.

(i). Passive modalities are most effective as adjunctive treatments to improve the results of active treatment. They may be used as found in Therapeutic Procedures, Non-operative.

(e). Steroid injections should generally be avoided in these patients since this is a risk for later rupture.

(f). Return to work with appropriate restrictions should be considered early in the course of treatment. Refer to Return to Work.

(g). Other therapies in Therapeutic Procedures, Non-operative may be employed in individual cases.

vi. Surgical Indications/Considerations: Total or partial rupture.

(a). Smoking may affect soft tissue healing through tissue hypoxia. Patients should be strongly encouraged to stop smoking and be provided with appropriate counseling by the physician.

vii. Operative Procedures: Repair of tendons open or percutaneously with or without anchors may be required. Tendon grafts are used for chronic cases or primary surgery failures when tendon tissue is poor.

viii. Post-Operative Treatment:

(a). An individualized rehabilitation program based upon communication between the surgeon and the therapist using therapies as outlined in Section F, Therapeutic Procedures, Non-operative.

(b). Treatment may include the following: restricted weight-bearing, bracing, active therapy with or without passive therapy.

(c). Range of motion may begin at three weeks depending on wound healing. Therapy and some restrictions will usually continue for six to eight weeks.

(d). Return to work and restrictions after surgery may be made by an attending physician experienced in occupational medicine in consultation with the surgeon or by the surgeon.

b. Aggravated Osteoarthritis:

i. Description/Definition: Internal joint pathology of ankle.

ii. Occupational Relationship: The provider must establish the occupational relationship by establishing a change in the patient's baseline condition and a relationship to work activities, for example frequent jumping, climbing, or squatting.

(a). Other causative factors to consider: Prior significant injury to the ankle may predispose the joint to osteoarthritis. In order to entertain previous trauma as a cause, the patient should have a medically documented injury with radiographs or MRI showing the level of anatomic change. The prior injury should have been at least two years from the presentation for the new complaints and there should be a significant increase of pathology on the affected side in comparison to the original imaging or operative reports and/or the opposite un-injured extremity.

iii. Specific Physical Exam Findings: Pain within joint, swelling. Crepitus, locking of the joint, reduced range of motion, pain with stress tests, angular deformities.

iv. Diagnostic Testing Procedures: X-ray – mechanical axis views, CT, MRI, diagnostic injection.

v. Non-operative Treatment Procedures:

(a). Initial Treatment: May include orthoses, custom shoes with rocker bottom shoe inserts, and braces. Cane may also be useful.

(b). Medications such as analgesics and anti-inflammatories may be helpful. Refer to medication discussions in Medications and Medical Management.

(c). Patient education should include instruction in self-management techniques, ergonomics, body mechanics, home exercise, joint protection, and weight management.

(d). Benefits may be achieved through therapeutic rehabilitation and rehabilitation interventions. They should include range-of-motion (ROM), active therapies, and a home exercise program. Active therapies include, proprioception training, restoring normal joint mechanics, and clearing dysfunctions from adjacent structures. Passive as well as active therapies may be used for control of pain and swelling. Therapy should progress to strengthening and an independent home exercise program targeted to further improve ROM, strength, and normal joint mechanics influenced by distal and proximal structures. Refer to Therapeutic Procedures, Non-operative.

(i). Passive modalities are most effective as adjunctive treatments to improve the results of active treatment. They may be used as found in Therapeutic Procedures, Non-operative.

(e). Steroid injections may decrease inflammation and allow the therapist to progress with functional exercise and range of motion. Steroid injections under significant pressure should be avoided as the needle may be penetrating the tendon and injection into the tendon can cause possible tendon breakdown, tendon degeneration, or rupture. Injections should be minimized for patients under 30 years of age.

(i). Time to Produce Effect: One injection.

(ii). Maximum Duration: Three injections in one year spaced at least four to eight weeks apart.

(iii). Steroid injections should be used cautiously in diabetic patients. Diabetic patients should be reminded to check their blood glucose levels at least daily for two weeks after injections.

(f). Return to work with appropriate restrictions should be considered early in the course of treatment. Refer to Return to Work.

(g). Other therapies in Therapeutic Procedures, Non-operative may be employed in individual cases.

#### vi. Surgical Indications/Considerations:

(a). The patient is a good surgical candidate and pain continues to interfere with ADLs after non-surgical interventions including weight control, therapy with active patient participation, and medication.

(b). Refer to Therapeutic Procedures-Operative, for specific indications for osteotomy, ankle fusion or arthroplasty.

(c). Implants are less successful than similar procedures in the knee or hip. There are no quality studies

comparing arthrodesis and ankle replacement. Patients with ankle fusions generally have good return to function and fewer complications than those with joint replacements. Salvage procedures for ankle replacement include revision with stemmed implant or allograft fusion. Given these factors, an ankle arthroplasty requires prior authorization and a second opinion by a surgeon specializing in lower extremity surgery.

(d). Prior to surgical intervention, the patient and treating physician should identify functional operative goals and the likelihood of achieving improved ability to perform activities of daily living or work activities and the patient should agree to comply with the pre- and post-operative treatment plan including home exercise. The provider should be especially careful to make sure the patient understands the amount of post-operative therapy required and the length of partial- and full-disability expected post-operatively.

(e). In cases where surgery is contraindicated due to obesity, it may be appropriate to recommend a weight loss program if the patient is unsuccessful losing weight on their own. Coverage for weight loss would continue only for motivated patients who have demonstrated continual progress with weight loss.

(f). Because smokers have a higher risk of non-union and post-operative costs, it is recommended that carriers cover a smoking cessation program peri-operatively. Physicians may monitor smoking cessation with laboratory tests such as cotinine levels for long-term cessation.

vii. Operative Procedures: Arthroscopy, ankle arthroplasty or fusion. Supramalleolar osteotomies can be considered for patients with deformities or pre-existing hind foot varus or valgus deformities.

#### viii. Post-Operative Treatment

(a). An individualized rehabilitation program based upon communication between the surgeon and the therapist using therapies as outlined in Section F, Therapeutic Procedures, Non-operative.

(b). In all cases, communication between the physician and therapist is important to the timing of weight-bearing and exercise progressions.

(c). Treatment may include the following: restricted weight-bearing, bracing, gait training and other active therapy with or without passive therapy.

(d). Refer to Ankle Fusion, Osteotomy, or Arthroplasty for further specific information.

(e). Return to work and restrictions after surgery may be made by an attending physician experienced in occupational medicine in consultation with the surgeon or by the surgeon.

#### c. Ankle or Subtalar Joint Dislocation:

i. Description/Definition: Dislocation of ankle or subtalar joint.

ii. Occupational Relationship: Usually occurs with falling or twisting.

iii. Specific Physical Exam Findings: Disruption of articular arrangements of ankle, subtalar joint may be tested using ligamentous laxity tests.

iv. Diagnostic Testing Procedures: Radiographs, CT scans. MRI may be used to assess for avascular necrosis of the talus which may occur secondary to a dislocation.

v. Non-operative Treatment Procedures:

(a). Initial Treatment: Closed reduction under anesthesia with pre- and post-reduction neurovascular assessment followed by casting and weight-bearing limitations.

(b). Medications such as analgesics and anti-inflammatories may be helpful. Refer to medication discussions in Medications and Medical Management.

(c). Patient education should include instruction in self-management techniques, ergonomics, body mechanics, home exercise, joint protection, and weight management.

(d). Benefits may be achieved through therapeutic rehabilitation and rehabilitation interventions. They should include range of motion (ROM), active therapies, and a home exercise program. Active therapies include, proprioception training, restoring normal joint mechanics, and clearing dysfunctions from adjacent structures. Passive as well as active therapies may be used for control of pain and swelling. Therapy should progress to strengthening and an independent home exercise program targeted to further improve ROM, strength, and normal joint mechanics influenced by distal and proximal structures. Refer to Therapeutic Procedures, Non-operative.

(i). Passive modalities are most effective as adjunctive treatments to improve the results of active treatment. They may be used as found in Therapeutic Procedures, Non-operative.

(e). Return to work with appropriate restrictions should be considered early in the course of treatment. Refer to Return to Work.

(f). Other therapies in Therapeutic Procedures, Non-operative may be employed in individual cases.

vi. Surgical Indications/Considerations: Inability to reduce closed fracture, association with unstable fractures

vii. Operative Procedures: Open or closed reduction of dislocation.

viii. Post-operative Treatment:

(a). An individualized rehabilitation program based upon communication between the surgeon and the therapist using therapies as outlined in Therapeutic Procedures, Non-operative.

(b). Treatment usually includes initial immobilization with restricted weight-bearing, followed by bracing and active therapy with or without passive therapy.

(c). Return to work and restrictions after surgery may be made by an attending physician experienced in occupational medicine in consultation with the surgeon or by the surgeon.

d. Ankle Sprain/Fracture

i. Description/Definition. An injury to the ankle joint due to abnormal motion of the talus that causes a stress on the malleolus and the ligaments. Injured ligaments in order of disruption include the anterior talofibular ligament (ATFL), calcaneofibular ligament (CFL), posterior talofibular ligament (PTFL), deltoid ligaments, and syndesmotic ligaments. Instability can result from a fracture of a malleolus (malleoli), rupture of ligaments, or a combination. Circumstances surrounding the injury, including consideration of location and additional injuries are of importance. Additionally, the position of the foot at the time of injury is helpful in determining the extent and type of injury. Grading of soft tissue injuries includes:

(a). Grade 1 Injury: those with overstretching or microscopic tears of the ligament, minimal swelling, normal stress testing, and the ability to bear weight.

(b). Grade 2 Injury: have partial disruption of the ligament, significant swelling, indeterminate results on stress testing, and difficulty bearing weight.

(c). Grade 3 Injury: have a ruptured ligament, swelling and ecchymosis, abnormal results on stress testing, and the inability to bear weight. May also include a chip avulsion fracture on x-ray.

ii. Occupational Relationship: sudden twisting, direct blunt trauma and falls. Inversion of the ankle with a plantar-flexed foot is the most common mechanism of injury.

iii. Specific Physical Exam Findings: varies with individual. With lower grade sprains the ankle may be normal appearing with minimal tenderness on examination. The ability/inability to bear weight, pain, swelling, or ecchymosis should be noted. If the patient is able to transfer weight from one foot onto the affected foot and has normal physical findings, then likelihood of fracture is reduced. Stress testing using the anterior drawer stress test, the talar tilt test and the external rotation stress test may be normal or abnormal depending on the involved ligament.

(a). Syndesmotic injury can occur with external rotation injuries and requires additional treatment. Specific physical exam tests include the squeeze test and external rotation at neutral.

iv. Diagnostic Testing Procedures: Radiographs. Refer to Initial Diagnostic Section which generally follows the Ottawa Ankle Rules. The Ottawa Ankle Rules are a decision aid for radiography. Commonly missed conditions include ankle syndesmosis or fractures. The instrument has a sensitivity of almost 100 percent and a modest specificity,

and its use should reduce the number of unnecessary radiographs by 30 to 40 percent.

(a). For an acute, unstable ankle or a repeat or chronic ankle injury, a MRI and/or diagnostic injection may be ordered. Arthroscopy can be used in unusual cases with persistent functional instability and giving way of the ankle, after conservative treatment, to directly visualize the ruptured ligament(s).

v. Non-operative Treatment Procedures

(a). Initial treatment for patients able to bear weight: NSAIDs, RICE (rest, ice, compression and elevation), and early functional bracing is used. In addition, crutches may be beneficial for comfort. Early functional treatment including range of motion and strengthening exercises along with limited weight-bearing, are preferable to strict immobilization with rigid casting for improving outcome and reducing time to return to work.

(b). Initial treatment for patients unable to bear weight: bracing plus NSAIDs and RICE are used. When patient becomes able to bear weight a walker boot is frequently employed. There is no clear evidence favoring ten days of casting over pneumatic bracing as initial treatment for patients who cannot bear weight three days post injury. There is good evidence that use of either device combined with functional therapy results in similar long-term recovery.

(i). There is some evidence that functional rehabilitation has results superior to six weeks of immobilization.

(ii). Small avulsion fractures of the fibula with minimal or no displacement can be treated as an ankle sprain.

(iii). For patients with a clearly unstable joint, immobilize with a short leg plaster cast or splint for two to six weeks along with early weight-bearing.

(c). Balance/coordination training is a well-established treatment which improves proprioception and may decrease incidence of recurrent sprains.

(d). Medications such as analgesics and anti-inflammatories may be helpful. Refer to medication discussions in Medications and Medical Management.

(e). Patient education should include instruction in self-management techniques, ergonomics, body mechanics, home exercise, joint protection, and weight management.

(f). Heel wedges or other orthotics may be used for rear foot varus or valgus deformities.

(i). There is good evidence that semi-rigid orthoses or pneumatic braces prevent ankle sprains during high risk physical activities and they should be used as appropriate after acute sprains.

(g). When fractures are involved refer to comments related to osteoporosis in Therapeutic Procedures, Non-operative, Osteoporosis Management.

(h). Smoking may affect fracture healing. Patients should be strongly encouraged to stop smoking and be provided with appropriate counseling by the physician.

(i). Return-to-work with appropriate restrictions should be considered early in the course of treatment. Refer to Return to Work.

(j). Other therapies in Therapeutic Procedures, Non-operative, including manual therapy may be employed in individual cases.

(k). Hyperbaric oxygen therapy is not recommended.

vi. Surgical Indications/Considerations:

(a). Acute surgical indications include sprains with displaced fractures, syndesmotic disruption or ligament sprain associated with a fracture causing instability.

(b). There is no conclusive evidence that surgery as opposed to functional treatment for an uncomplicated Grade I-III ankle sprain improves patient outcome.

(c). Chronic indications are functional problems, such as recurrent instability, remaining after at least 2 months of appropriate therapy including active participation in a non-operative therapy program including balance training.

(d). Prior to surgical intervention, the patient and treating physician should identify functional operative goals and the likelihood of achieving improved ability to perform activities of daily living or work activities and the patient should agree to comply with the pre- and post-operative treatment plan including home exercise. The provider should be especially careful to make sure the patient understands the amount of post-operative therapy required and the length of partial- and full-disability expected post-operatively.

(e). If injury is a sprain: Smoking may affect soft tissue healing through tissue hypoxia. Patients should be strongly encouraged to stop smoking and be provided with appropriate counseling by the physician.

(f). If injury is a fracture: Because smokers have a higher risk of non-union and post-operative costs, it is recommended that carriers cover a smoking cessation program peri-operatively. Physicians may monitor smoking cessation with laboratory tests such as cotinine levels for long-term cessation.

vii. Operative Treatment: Repair of fractures or other acute pathology as necessary. Primary ligament ankle reconstruction with possible tendon transplant.

viii. Post-Operative Treatment

(a). An individualized rehabilitation program based upon communication between the surgeon and the therapist using therapies as outlined in Therapeutic Procedures, Non-operative. Treatment may include short-term post surgical casting. In all cases, communication between the physician and therapist is important to the timing of weight-bearing and exercise progressions.

(i). There is some evidence that more rapid recovery occurs with functional rehabilitation compared to six weeks of immobilization in a cast.

(b). The surgical procedures and the patient's individual results dictate the amount of time a patient has non weight-bearing restrictions. Fractures usually require six to eight weeks while tendon transfers may be six weeks. Other soft tissue repairs, such as the Brostrom lateral ankle stabilization, may be as short as three weeks.

(c). Return to work and restrictions after surgery may be made by an attending physician experienced in occupational medicine in consultation with the surgeon or by the surgeon.

e. Calcaneal Fracture:

i. Description/Definition: Osseous fragmentation/separation confirmed by diagnostic studies.

ii. Occupational Relationship: Usually occurs by fall or crush injury.

iii. Specific Physical Exam Findings: Pain with range of motion and palpation of calcaneus. Inability to bear weight, mal-positioning of heel, possible impingement of sural nerve.

iv. Diagnostic Testing Procedures: Radiographs and CT scan to assess for intra-articular involvement. Lumbar films and urinalysis are usually performed to rule out lumbar crush fractures when the mechanism of injury is a fall from a height.

v. Non-operative Treatment Procedures:

(a). Initial Treatment: Non weight-bearing six to eight weeks, followed by weight-bearing cast at physician's discretion and active therapy with or without passive therapy.

(b). Medications such as analgesics and anti-inflammatories may be helpful. Refer to medication discussions in Medications and Medical Management.

(c). Patient education should include instruction in self-management techniques, ergonomics, body mechanics, home exercise, joint protection, and weight management.

(d). Refer to comments related to osteoporosis in Therapeutic Procedures, Non-operative, Osteoporosis Management.

(e). Smoking may affect fracture healing. Patients should be strongly encouraged to stop smoking and be provided with appropriate counseling by the physician.

(f). Return to work with appropriate restrictions should be considered early in the course of treatment. Refer to Return to Work.

(g). Other therapies in Therapeutic Procedures, Non-operative may be employed in individual cases.

vi. Surgical Indications/Considerations: Displacement of fragments, joint depression, intra-articular

involvement, mal-position of heel. Sanders Types II and III are generally repaired surgically. However, the need for surgery will depend on the individual case. Relative contraindications: smoking, diabetes, or immunosuppressive disease.

(a). Because smokers have a higher risk of non-union and post-operative costs, it is recommended that carriers cover a smoking cessation program peri-operatively. Physicians may monitor smoking cessation with laboratory tests such as cotinine levels for long-term cessation.

vii. Operative Procedures: Open reduction internal fixation. Subtalar fusion may be necessary in some cases when the calcaneus is extremely comminuted. External fixation has been used when the skin condition is poor.

(a). Complications may include wound infections requiring skin graft.

viii. Post-operative Treatment:

(a). An individualized rehabilitation program based upon communication between the surgeon and the therapist using the therapies as outlined in Section F, Therapeutic Procedures, Non-operative. In all cases, communication between the physician and therapist is important to the timing of weight-bearing and exercise progressions.

(b). The patient is usually non weight-bearing for six to eight weeks followed by weight-bearing for approximately six to eight weeks at physician's discretion.

(c). Treatment may include the following: restricted weight-bearing, bracing, active therapy with or without passive therapy.

(d). Return to work and restrictions after surgery may be made by an attending physician experienced in occupational medicine in consultation with the surgeon or by the surgeon.

f. Chondral and Osteochondral Defects:

i. Description/Definition: Cartilage or cartilage and bone defect of the talar surface. May be associated with ankle sprain or other injuries.

ii. Occupational Relationship: Usually caused by a traumatic ankle injury.

iii. Specific Physical Exam Findings: Ankle effusion, pain in joint and with walking.

iv. Diagnostic Testing Procedures: MRI may show bone bruising, osteochondral lesion, or possibly articular cartilage injury. Radiographs, contrast radiography, CT may also be used.

v. Non-Operative Treatment Procedures:

(a). Initial Treatment: Acute injuries may require immobilization followed by active therapy with or without passive therapy.

(b). Medications such as analgesics and anti-inflammatories may be helpful. Refer to medication discussions in Medications and Medical Management.

(c). Patient education should include instruction in self-management techniques, ergonomics, body mechanics, home exercise, joint protection, and weight management.

(d). Benefits may be achieved through therapeutic rehabilitation and rehabilitation interventions. They should include range-of-motion (ROM), active therapies, and a home exercise program. Active therapies include, proprioception training, restoring normal joint mechanics, and clearing dysfunctions from adjacent structures. Passive as well as active therapies may be used for control of pain and swelling. Therapy should progress to strengthening and an independent home exercise program targeted to further improve ROM, strength, and normal joint mechanics influenced by distal and proximal structures. Refer to Therapeutic Procedures, Non-operative.

(i). Passive modalities are most effective as adjunctive treatments to improve the results of active treatment. They may be used as found in Therapeutic Procedures, Non-operative.

(e). Return to work with appropriate restrictions should be considered early in the course of treatment. Refer to Return to Work.

(f). Other therapies in Therapeutic Procedures, Non-operative may be employed in individual cases.

#### vi. Surgical Indications/Considerations

(a). Functional deficits not responsive to conservative therapy. Identification of an osteochondral lesion by diagnostic testing procedures should be done to determine the size of the lesion and stability of the joint.

(b). Microfracture is the initial treatment unless there are other anatomic variants such as a cyst under the bone.

(c). Osteochondral Autograft Transfer System (OATS) may be effective in patients without other areas of osteoarthritis, a BMI of less than 35 and a failed microfracture. This procedure may be indicated when functional deficits interfere with activities of daily living and/or job duties 6 to 12 weeks after a failed microfracture with active patient participation in non-operative therapy. This procedure is only appropriate in a small subset of patients.

(d). Autologous cartilage cell implant is not FDA approved for the ankle and therefore not recommended.

(e). Prior to surgical intervention, the patient and treating physician should identify functional operative goals and the likelihood of achieving improved ability to perform activities of daily living or work activities and the patient should agree to comply with the pre- and post-operative treatment plan including home exercise. The provider should be especially careful to make sure the patient understands

the amount of post-operative therapy required and the length of partial- and full-disability expected post-operatively.

(f). Smoking may affect tissue healing through tissue hypoxia. Patients should be strongly encouraged to stop smoking and be provided with appropriate counseling by the physician.

vii. Operative Procedures: Arthroscopy with debridement or shaving of cartilage, microfracture, mosaicplasty, fixation of loose osteochondral fragments.

#### viii. Post-Operative Treatment

(a). An individualized rehabilitation program based upon communication between the surgeon and the therapist and using therapies as outlined in Therapeutic Procedures, Non-operative. In all cases, communication between the physician and therapist is important to the timing of weight-bearing and exercise progressions.

(b). Treatment may include the following: restricted weight-bearing, bracing, active therapy with or without passive therapy.

(c). Return to work and restrictions after surgery may be made by an attending physician experienced in occupational medicine in consultation with the surgeon or by the surgeon.

#### g. Heel Spur Syndrome/Plantar Fasciitis:

i. Description: Pain along the inferior aspect of the heel at the calcaneal attachment of the plantar fascia and/or along the course of the plantar fascia.

ii. Occupational Relationship: Condition may be exacerbated by prolonged standing or walking on hard surfaces. Acute injury may be caused by trauma. This may include jumping from a height or hyperextension of the forefoot upon the rear foot.

iii. Specific Physical Exam Findings: Pain with palpation at the inferior attachment of the plantar fascia to the os calcis may be associated with calcaneal spur. Gastrocnemius tightness may be tested with the Silfverskiöld test. The foot is dorsiflexed with the knee extended and then with the knee flexed. The test for gastrocnemius tightness is considered positive if dorsiflexion is greater with the knee flexed than with the knee extended.

iv. Diagnostic Testing Procedures: Standard radiographs to rule out fracture, identify spur after conservative therapy. Bone scans and/or MRI may be used to rule out stress fractures in chronic cases.

#### v. Non-operative Treatment Procedures:

(a). Initial Treatment: This condition usually responds to conservative management consisting of eccentric exercise of the gastrocnemius, plantar fascial stretching, taping, soft-tissue mobilization, night splints, and orthotics. Therapy may include passive therapy, taping, and injection therapy.

(b). Shock absorbing shoe inserts may prevent back and lower extremity problems in some work settings.

(c). Medications such as analgesics and anti-inflammatories may be helpful. Refer to medication discussions in Medications and Medical Management.

(d). Patient education should include instruction in self-management techniques, ergonomics, body mechanics, home exercise, joint protection, and weight management.

(e). Steroid injections may decrease inflammation and allow the therapist to progress with functional exercise and range of motion. Steroid injections under significant pressure should be avoided as the needle may be penetrating the tendon and injection into the tendon can cause possible tendon breakdown, tendon degeneration, or rupture. Injections should be minimized for patients under 30 years of age.

(i). Time to Produce Effect: One injection.

(ii). Maximum Duration: Three injections in one year spaced at least four to eight weeks apart.

(iii). Steroid injections should be used cautiously in diabetic patients. Diabetic patients should be reminded to check their blood glucose levels at least daily for two weeks after injections.

(f). Return to work with appropriate restrictions should be considered early in the course of treatment. Refer to Return to Work.

(g). After four months of failed therapy, Extracorporeal Shock Wave Therapy (ESWT) trial may be considered prior to surgery. Refer to Therapeutic Procedures, Non-operative.

(h). Other therapies in Therapeutic Procedures, Non-operative may be employed in individual cases.

vi. Surgical Indications/Considerations:

(a). Surgery is employed only after failure of at least four to six months of active patient participation in non-operative treatment.

(b). Indications for a gastrocnemius recession include a positive Silfverskiöld test. This procedure does not weaken the arch as may occur with a plantar fascial procedure, however, there is a paucity of literature on this procedure.

(c). Prior to surgical intervention, the patient and treating physician should identify functional operative goals and the likelihood of achieving improved ability to perform activities of daily living or work activities and the patient should agree to comply with the pre- and post-operative treatment plan including home exercise. The provider should be especially careful to make sure the patient understands the amount of post-operative therapy required and the length of partial- and full-disability expected post-operatively.

(d). Smoking may affect soft tissue healing through tissue hypoxia. Patients should be strongly encouraged to stop smoking and be provided with appropriate counseling by the physician.

vii. Operative Treatment Procedures: Plantar fascial release with or without calcaneal spur removal, endoscopic or open gastrocnemius recession.

viii. Post-Operative Treatment

(a). An individualized rehabilitation program based upon communication between the surgeon and the therapist using therapies as outlined in Therapeutic Procedures, Non-operative.

(b). Treatment may include the following: restricted weight-bearing, bracing, active therapy with or without passive therapy. Usually non weight-bearing for 7 to 10 days followed by weight-bearing cast or shoe for four weeks; however, depending on the procedure some patients may be restricted from weight-bearing for four to six weeks.

(c). Return to work and restrictions after surgery may be made by an attending physician experienced in occupational medicine in consultation with the surgeon or by the surgeon.

h. Metatarsal-Phalangeal, Tarsal-Metatarsal and Interphalangeal Joint Arthropathy:

i. Description/Definition: Internal derangement of joint.

ii. Occupational Relationship: Jamming, contusion, crush injury, repetitive impact, or post-traumatic arthrosis.

iii. Specific Physical Exam Findings. Pain with palpation and ROM of joint, effusion. The piano key test may be used, where the examiner stabilizes the heel with one hand and presses down on the distal head of the metatarsals, assessing for pain proximally.

iv. Diagnostic Testing Procedures. Radiographs, diagnostic joint injection, CT, MRI.

v. Non-operative Treatment Procedures

(a). Medications such as analgesics and anti-inflammatories may be helpful. Refer to medication discussions in Medications and Medical Management.

(b). Patient education should include instruction in self-management techniques, ergonomics, body mechanics, home exercise, joint protection, and weight management.

(c). Benefits may be achieved through therapeutic rehabilitation and rehabilitation interventions. They should include range-of-motion (ROM), active therapies, and a home exercise program. Active therapies include, proprioception training, restoring normal joint mechanics, and clearing dysfunctions from adjacent structures. Passive as well as active therapies may be used for control of pain and swelling. Orthotics and iontophoresis are usually included. A carbon fiber Morton extension may be useful. Therapy should progress to strengthening and an independent home exercise program targeted to further improve ROM, strength, and normal joint mechanics



influenced by distal and proximal structures. Refer to Therapeutic Procedures, Non-operative.

(i). Passive modalities are most effective as adjunctive treatments to improve the results of active treatment. They may be used as found in Therapeutic Procedures, Non-operative.

(d). Steroid injections may decrease inflammation and allow the therapist to progress with functional exercise and range of motion. Steroid injections under significant pressure should be avoided as the needle may be penetrating the tendon and injection into the tendon can cause possible tendon breakdown, tendon degeneration, or rupture. Injections should be minimized for patients under 30 years of age.

(i). Time to Produce Effect: One injection.

(ii). Maximum Duration: Three injections in one year spaced at least four to eight weeks apart.

(iii). Steroid injections should be used cautiously in diabetic patients. Diabetic patients should be reminded to check their blood glucose levels at least daily for two weeks after injections.

(e). Return to work with appropriate restrictions should be considered early in the course of treatment. Refer to Return to Work.

(f). Other therapies in Therapeutic Procedures, Non-operative may be employed in individual cases.

#### vi. Surgical Indications/Considerations

(a). Pain, unresponsive to conservative care and interfering with activities of daily living.

(b). First metatarsal arthritis or avascular necrosis can interfere with function and gait.

(c). Prior to surgical intervention, the patient and treating physician should identify functional operative goals and the likelihood of achieving improved ability to perform activities of daily living or work activities and the patient should agree to comply with the pre- and post-operative treatment plan including home exercise. The provider should be especially careful to make sure the patient understands the amount of post-operative therapy required and the length of partial- and full-disability expected post-operatively.

(d). Smoking may affect soft tissue healing through tissue hypoxia. Patients should be strongly encouraged to stop smoking and be provided with appropriate counseling by the physician.

vii. Operative Procedures: if debridement of the arthritic joint and other conservative treatment is unsuccessful in correcting gait and walking tolerance, other procedures may be considered. Other procedures include: fusion of first metatarsal-phalangeal joint, chilectomy, osteotomies, Keller arthroplasty and soft tissue procedures.

(a). There is some evidence that the first metatarsal-phalangeal joint arthritis is better treated with arthrodesis than arthroplasty for pain and functional

improvement. Therefore, total joint arthroplasties are not recommended for any metatarsal-phalangeal joints due to less successful outcomes than fusions. There may be an exception for first and second metatarsal-phalangeal joint arthroplasties when a patient is older than 60, has low activity levels, and cannot tolerate non weight-bearing for prolonged periods or is at high risk for non-union.

(b). Metallic hemi-arthroplasties are still considered experimental as long-term outcomes remain unknown in comparison to arthrodesis, and there is a significant incidence of subsidence. Therefore, these are not recommended at this time.

#### viii. Post-Operative Treatment

(a). An individualized rehabilitation program based upon communication between the surgeon and the therapist using therapies as outlined in Therapeutic Procedures, Non-operative. In all cases, communication between the physician and therapist is important to the timing of weight-bearing and exercise progressions.

(b). For fusions and osteotomies, reduced weight-bearing and the use of special shoes will be necessary for at least six weeks post operative. For other procedures early range-of-motion, bracing, and/or orthotics. Treatment usually also includes other active therapy with or without passive therapy.

(c). Return to work and restrictions after surgery may be made by an attending physician experienced in occupational medicine in consultation with the surgeon or by the surgeon.

#### i. Midfoot (Lisfranc) Fracture/Dislocation

i. Description/Definition: Fracture/ligamentous disruption of the tarsal-metatarsal joints, i.e., metatarsal-cuneiform and metatarsal-cuboid bones.

ii. Occupational Relationship: Usually occurs from a fall, crush, axial load with a plantar flexed foot, or abductory force on the forefoot.

iii. Specific Physical Exam Findings. Pain and swelling at the Lisfranc joint, first and/or second metatarsal cuneiform articulation, palpable dorsal dislocation, pain on forced abduction.

(a). Dislocation may not always be apparent. Pronation and supination of the forefoot with the calcaneus fixed in the examiners opposite hand may elicit pain in a Lisfranc injury, distinguishing it from an ankle sprain, in which this maneuver is expected to be painless. The piano key test may be used, where the examiner stabilizes the heel with one hand and presses down on the distal head of the metatarsal, assessing for pain proximally. The dorsalis pedis artery crosses the second metatarsal and may be disrupted. Therefore, the dorsalis pedis pulse and capillary filling should be assessed.

iv. Diagnostic Testing Procedures: X-rays, CT scans, MRI, mid-foot stress x-rays.

v. Non-operative Treatment Procedures:

(a). Initial Treatment: If minimal or no displacement then casting, non weight-bearing six to eight weeks. Orthoses may be used later.

(b). Medications such as analgesics and anti-inflammatories may be helpful. Refer to medication discussions in Medications and Medical Management.

(c). Patient education should include instruction in self-management techniques, ergonomics, body mechanics, home exercise, joint protection, and weight management.

(d). Refer to comments related to osteoporosis in Therapeutic Procedures, Non-operative, Osteoporosis Management.

(e). Smoking may affect fracture healing. Patients should be strongly encouraged to stop smoking and be provided with appropriate counseling by the physician.

(f). Return to work with appropriate restrictions should be considered early in the course of treatment. Refer to Return to Work.

(g). Other therapies in Therapeutic Procedures, Non-operative may be employed in individual cases.

vi. Surgical Indications/Considerations: Displacement of fragments or intra-articular fracture. Most Lisfranc fracture/dislocations are treated surgically.

(a). Because smokers have a higher risk of non-union and post-operative costs, it is recommended that carriers cover a smoking cessation program peri-operatively. Physicians may monitor smoking cessation with laboratory tests such as cotinine levels for long-term cessation.

vii. Operative Procedures: Open reduction internal fixation with possible removal of hardware at approximately three to six months, pending healing status. Alternatively, arthrodesis of the medial two or three metatarsals.

viii. Post-Operative Treatment

(a). An individualized rehabilitation program based upon communication between the surgeon and the therapist using treatments as outlined in Therapeutic Procedures, Non-operative. In all cases, communication between the physician and therapist is important to the timing of weight-bearing and exercise progressions.

(b). The patient is usually in cast or fracture walker for six to eight weeks non weight-bearing. Orthoses may be indicated after healing.

(c). Treatment may include the following: restricted weight-bearing, bracing, active therapy with or without passive therapy.

(d). Return to work and restrictions after surgery may be made by an attending physician experienced in occupational medicine in consultation with the surgeon or by the surgeon.

j. Morton's Neuroma

i. Description. This condition is a perineural fibrosis of the intermetatarsal nerve creating pain and/or paresthesias in the forefoot region. Symptoms appear with weight-bearing activities. Usually occurs between the third and fourth metatarsals or between the second and third metatarsals.

ii. Occupational Relationship. Acute injuries may include excessive loading of the forefoot region caused from jumping or pushing down on the ball of the foot. Non-traumatic occurrences are determined at physician's discretion after review of environmental and biomechanical risk factors.

iii. Specific Physical Exam Findings. Paresthesias and/or pain with palpation of the inter-metatarsal nerve. Mulder's sign, a palpable click from compression of the nerve, or Tinel's sign.

iv. Diagnostic Testing Procedures. Radiographs to rule out osseous involvement. Diagnostic and therapeutic injections. Diagnosis is usually based on clinical judgment; however, MRI and ultrasound imaging have also been employed in difficult cases.

v. Non-operative Treatment Procedures

(a). Initial Treatment: Nonsteroidal anti-inflammatories and foot orthoses are primary treatments.

(b). Medications such as analgesics and anti-inflammatories are usually helpful. Refer to medication discussions in Medications and Medical Management.

(c). Patient education should include instruction in self-management techniques, ergonomics, body mechanics, home exercise, joint protection, and weight management.

(d). Steroid injections may decrease inflammation and allow the therapist to progress with functional exercise and range of motion. Steroid injections under significant pressure should be avoided as the needle may be penetrating the tendon and injection into the tendon can cause possible tendon breakdown, tendon degeneration, or rupture. Injections should be minimized for patients under 30 years of age.

(i). Time to Produce Effect: One injection.

(ii). Maximum Duration: Three injections in one year spaced at least four to eight weeks apart.

(iii). Steroid injections should be used cautiously in diabetic patients. Diabetic patients should be reminded to check their blood glucose levels at least daily for two weeks after injections.

(e). Alcohol injections are thought to produce a chemical neurolysis. Alcohol injection with ultrasound guidance may be used to decrease symptoms.

(i). Optimum Duration: Four treatments.

(ii). Maximum Duration: Seven treatments.

(f). Return to work with appropriate restrictions should be considered early in the course of treatment. Refer to Return to Work.

(g). Other therapies in Therapeutic Procedures, Non-operative may be employed in individual cases.

vi. Surgical Indications/Considerations:

(a). Functional deficits persisting after two to three months of active participation in therapy.

(b). Prior to surgical intervention, the patient and treating physician should identify functional operative goals and the likelihood of achieving improved ability to perform activities of daily living or work activities and the patient should agree to comply with the pre- and post-operative treatment plan including home exercise. The provider should be especially careful to make sure the patient understands the amount of post-operative therapy required and the length of partial- and full-disability expected post-operatively.

(c). Smoking may affect soft tissue healing through tissue hypoxia. Patients should be strongly encouraged to stop smoking and be provided with appropriate counseling by the physician.

vii. Operative Procedures: Excision of the neuroma; nerve transection or transposition.

viii. Post-Operative Treatment

(a). An individualized rehabilitation program based upon communication between the surgeon and the therapist using therapies as outlined in Therapeutic Procedures, Non-operative.

(b). Treatment may involve a period of non weight-bearing for up to two weeks, followed by gradual protected weight-bearing four to six weeks.

(c). Return to work and restrictions after surgery may be made by an attending physician experienced in occupational medicine in consultation with the surgeon or by the surgeon.

k. Pilon Fracture

i. Description/Definition: Crush/comminution fracture of distal metaphyseal tibia that has intra-articular extensions into the weight-bearing surface of the tibio-talar joint.

ii. Occupational Relationship: Usually from a fall.

iii. Specific Physical Exam Findings: Swelling, pain with weight-bearing, ecchymosis, and palpable tenderness.

iv. Diagnostic Testing Procedures: Radiographs, CT scans.

v. Non-operative Treatment Procedures

(a). Initial Treatment: Prolonged non weight-bearing at physician's discretion.

(b). Medications such as analgesics and anti-inflammatories may be helpful. Refer to medication discussions in Medications and Medical Management.

(c). Patient education should include instruction in self-management techniques, ergonomics, body mechanics, home exercise, joint protection, and weight management.

(d). Refer to comments related to osteoporosis in Therapeutic Procedures, Non-operative, Osteoporosis Management.

(e). Smoking may affect fracture healing. Patients should be strongly encouraged to stop smoking and be provided with appropriate counseling by the physician.

(f). Return to work with appropriate restrictions should be considered early in the course of treatment. Refer to Return to Work.

(g). Other therapies in Therapeutic Procedures, Non-operative may be employed in individual cases.

vi. Surgical Indications/Considerations: Displacement of fracture, severe comminution necessitating primary fusion.

(a). Because smokers have a higher risk of non-union and post-operative costs, it is recommended that insurers cover a smoking cessation program peri-operatively. Physicians may monitor smoking cessation with laboratory tests such as cotinine levels for long-term cessation.

vii. Operative Procedures: Open reduction internal fixation, fusion, external fixation. In some cases staged procedures may be necessary beginning with external fixation.

viii. Post-Operative Treatment

(a). An individualized rehabilitation program based upon communication between the surgeon and the therapist using treatment as outlined in Therapeutic Procedures, Non-operative. In all cases, communication between the physician and therapist is important to the timing of weight-bearing and exercise progressions.

(b). Treatment may include the following: restricted weight-bearing, bracing, active therapy with or without passive therapy.

(c). Return to work and restrictions after surgery may be made by an attending physician experienced in occupational medicine in consultation with the surgeon or by the surgeon.

l. Posterior Tibial Tendon Dysfunction

i. Description/Definition: Pain in the posteromedial ankle with plantar flexion.

ii. Occupational Relationship: Repetitive or forced plantar flexion after an ankle sprain or athletic activity.

iii. Specific Physical Exam Findings: Painful posterior tibial tendon with active and passive non weight-

bearing motion, reproduction of pain with forced plantar flexion and inversion of the ankle, difficulty performing single heel raise, pain with palpation from the posterior medial foot along the medial malleolus to the navicular greater tuberosity. The patient should also be evaluated for a possible weak gluteus medius as a contributing factor.

iv. Diagnostic Testing Procedures: X-ray, MRI may be used to rule out other diagnoses.

v. Non-operative Treatment Procedures:

(a). Initial Treatment: Short ankle articulated orthosis and therapy including low-load strengthening exercises with progression to home program. Other active and passive therapy including iontophoresis, orthotics and possible strengthening for the gluteus medius.

(b). Medications such as analgesics and anti-inflammatories may be helpful. Refer to medication discussions in Medications and Medical Management.

(c). Patient education should include instruction in self-management techniques, ergonomics, body mechanics, home exercise, joint protection, and weight management.

(d). Return to work with appropriate restrictions should be considered early in the course of treatment. Refer to Return to Work.

(e). Other therapies in Therapeutic Procedures, Non-operative may be employed in individual cases.

vi. Surgical Indications/Considerations:

(a). Failure of non-operative treatment. Surgery is rarely necessary as success rate for non-operative treatment is around 90 percent.

(b). Prior to surgical intervention, the patient and treating physician should identify functional operative goals and the likelihood of achieving improved ability to perform activities of daily living or work activities and the patient should agree to comply with the pre- and post-operative treatment plan including home exercise. The provider should be especially careful to make sure the patient understands the amount of post-operative therapy required and the length of partial- and full-disability expected post-operatively.

(c). Smoking may affect soft tissue healing through tissue hypoxia. Patients should be strongly encouraged to stop smoking and be provided with appropriate counseling by the physician.

vii. Operative Procedures: Resection of anomolous muscle segments or tenolysis. In severe cases, tendon transfer, osteotomies and/or arthrodesis may be necessary.

viii. Post-Operative Treatment:

(a). An individualized rehabilitation program based upon communication between the surgeon and the therapist and using therapies as outlined in Therapeutic Procedures, Non-Operative.

(b). Treatment may include the following: restricted weight-bearing, bracing, active therapy with or without passive therapy.

(c). Return to work and restrictions after surgery may be made by an attending physician experienced in occupational medicine in consultation with the surgeon or by the surgeon.

m. Puncture Wounds of the Foot

i. Description/Definition: Penetration of skin by foreign object.

ii. Occupational Relationship: Usually by stepping on foreign object, open wound.

iii. Specific Physical Exam Findings: Site penetration by foreign object consistent with history. In early onset, may show classic signs of infection.

iv. Diagnostic Testing Procedures: X-ray, MRI, ultrasound.

v. Non-operative Treatment Procedures

(a). Initial Treatment: Appropriate antibiotic therapy, tetanus toxoid booster, non weight-bearing at physician's discretion.

(b). Medications such as analgesics and anti-inflammatories may be helpful. Refer to medication discussions in Medications and Medical Management.

(c). Patient education should include instruction in self-management techniques, ergonomics, body mechanics, home exercise, joint protection, and weight management.

(d). Return to work with appropriate restrictions should be considered early in the course of treatment. Refer to Return to Work.

(e). Other therapies in Therapeutic Procedures, Non-operative may be employed in individual cases.

vi. Surgical Indications/Considerations: Cellulitis, retained foreign body suspected, abscess, compartmental syndrome, and bone involvement.

(a). Smoking may affect soft tissue healing through tissue hypoxia. Patients should be strongly encouraged to stop smoking and be provided with appropriate counseling by the physician.

vii. Operative Procedures: Incision and drainage with cultures.

viii. Post-Operative Treatment

(a). Patient is usually non-weight-bearing with antibiotic therapy based upon cultures. Follow-up x-rays and/or MRI may be needed to evaluate for osseous involvement.

(b). An individualized rehabilitation program based upon communication between the surgeon and the therapist using treatment as outlined in Therapeutic Procedures, Non-operative.

(c). Return to work and restrictions after surgery may be made by an attending physician experienced in occupational medicine in consultation with the surgeon or by the surgeon.

n. Severe Soft Tissue Crush Injuries:

i. Description/Definition: Soft tissue damage to the foot.

ii. Occupational Relationship: Crush injury or heavy impact to the foot or ankle.

iii. Specific Physical Exam Findings: Pain and swelling over the foot.

iv. Diagnostic Testing Procedures: X-ray and other tests as necessary to rule out other possible diagnoses such as compartment syndrome which requires emergent compartment pressure assessment.

v. Non-operative Treatment Procedures:

(a). Initial Treatment: Usually needs initial rest from work with foot elevation and compression wraps.

(b). Medications such as analgesics and anti-inflammatories may be helpful. Refer to medication discussions in Medications and Medical Management.

(c). Patient education should include instruction in self-management techniques, ergonomics, body mechanics, home exercise, joint protection, and weight management.

(d). Benefits may be achieved through therapeutic rehabilitation and rehabilitation interventions. They should include range-of-motion (ROM), active therapies, and a home exercise program. Active therapies include, proprioception training, restoring normal joint mechanics, and clearing dysfunctions from adjacent structures. Passive as well as active therapies may be used for control of pain and swelling. Therapy should progress to strengthening and an independent home exercise program targeted to further improve ROM, strength, and normal joint mechanics influenced by distal and proximal structures. Refer to Therapeutic Procedures, Non-operative.

(i). Passive modalities are most effective as adjunctive treatments to improve the results of active treatment. They may be used as found in Therapeutic Procedures, Non-operative.

(e). Return to work with appropriate restrictions should be considered early in the course of treatment. Refer to Return to Work.

(f). Other therapies in Therapeutic Procedures, Non-operative may be employed in individual cases.

vi. Surgical Indications/Considerations: If compartmental pressures are elevated, emergent fasciotomy is warranted.

(a). Smoking may affect soft tissue healing through tissue hypoxia. Patients should be strongly

encouraged to stop smoking and be provided with appropriate counseling by the physician.

vii. Operative Procedures: Emergency fasciotomy. In some cases a delayed primary closure is necessary.

viii. Post-Operative Treatment

(a). An individualized rehabilitation program based upon communication between the surgeon and the therapist and using therapies as outlined in Section F, Therapeutic Procedures, Non-operative.

(b). Treatment may include the following: elevation, restricted weight-bearing, active therapy with or without passive therapy.

(c). Return to work and restrictions after surgery may be made by an attending physician experienced in occupational medicine in consultation with the surgeon or by the surgeon.

o. Stress Fracture

i. Description/Definition: Fracture without displacement usually to metatarsals, talus, navicular or calcaneus.

ii. Occupational Relationship: May be related to repetitive, high impact walking; running; or jumping.

iii. Specific Physical Exam Findings: Pain over the affected bone with palpation or weight-bearing.

iv. Diagnostic Testing Procedures: X-ray, CT, MRI, bone scan

v. Non-Operative Treatment Procedures

(a). Initial Treatment: Immobilization for four to eight weeks with limited weight-bearing may be appropriate.

(b). Medications such as analgesics and anti-inflammatories may be helpful. Refer to medication discussions in Medications and Medical Management.

(c). Patient education should include instruction in self-management techniques, ergonomics, body mechanics, home exercise, joint protection, and weight management.

(d). Refer to comments related to osteoporosis in Therapeutic Procedures, Non-operative, Osteoporosis Management.

(e). Smoking may affect fracture healing. Patients should be strongly encouraged to stop smoking and be provided with appropriate counseling by the physician.

(f). There is some evidence that shock absorbing boot inserts may decrease the incidence of stress fractures in military training. Shock absorbing boot inserts of other orthotics may be used in some cases after a stress fracture has occurred or to prevent stress fractures in appropriate work settings.

(g). Return to work with appropriate restrictions should be considered early in the course of treatment. Refer to Return to Work.

(h). Other therapies in Therapeutic Procedures, Non-operative may be employed in individual cases.

vi. Surgical Indications/Considerations: Fractures that have not responded to conservative therapy.

(a). Because smokers have a higher risk of non-union and post-operative costs, it is recommended that insurers cover a smoking cessation program peri-operatively. Physicians may monitor smoking cessation with laboratory tests such as cotinine levels for long-term cessation.

vii. Operative Procedures: Most commonly percutaneous screws or plate fixation.

viii. Post-Operative Treatment

(a). An individualized rehabilitation program based upon communication between the surgeon and the therapist and using therapies as outlined in Section F, Therapeutic Procedures, Non-operative. In all cases, communication between the physician and therapist is important to the timing of weight-bearing and exercise progressions.

(b). Treatment may include the following: restricted weight-bearing, bracing, active therapy with or without passive therapy.

(c). Return to work and restrictions after surgery may be made by an attending physician experienced in occupational medicine in consultation with the surgeon or by the surgeon.

p. Talar Fracture

i. Description/Definition: Osseous fragmentation of talus confirmed by radiographic, CT or MRI evaluation.

ii. Occupational Relationship: Usually occurs from a fall or crush injury.

iii. Specific Physical Exam Findings: Clinical findings consistent with fracture of talus: pain with range of motion, palpation, swelling, ecchymosis. Pain with weight-bearing attempt.

iv. Diagnostic Testing Procedures: Radiographs, CT scans, MRI. CT scans preferred for spatial alignment.

v. Non-Operative Treatment Procedures

(a). Initial Treatment: Non weight-bearing for six to eight weeks for non-displaced fractures.

(b). Medications such as analgesics and anti-inflammatories may be helpful. Refer to medication discussions in Medications and Medical Management.

(c). Patient education should include instruction in self-management techniques, ergonomics, body mechanics, home exercise, joint protection, and weight management.

(d). Refer to comments related to osteoporosis in Therapeutic Procedures, Non-operative, Osteoporosis Management.

(e). Smoking may affect fracture healing. Patients should be strongly encouraged to stop smoking and be provided with appropriate counseling by the physician.

(f). Return to work with appropriate restrictions should be considered early in the course of treatment. Refer to Return to Work.

(g). Other therapies in Therapeutic Procedures, Non-operative may be employed in individual cases.

vi. Surgical Indications/Considerations: Osseous displacement, joint involvement and instability.

(a). Because smokers have a higher risk of non-union and post-operative costs, it is recommended that carriers cover a smoking cessation program peri-operatively. Physicians may monitor smoking cessation with laboratory tests such as cotinine levels for long-term cessation.

vii. Operative Procedures: Open reduction internal fixation.

viii. Post-Operative Treatment

(a). An individualized rehabilitation program based upon communication between the surgeon and the therapist and using therapies as outlined in Therapeutic Procedures, Non-operative. In all cases, communication between the physician and therapist is important to the timing of weight-bearing and exercise progressions.

(b). Treatment may include the following: Non weight-bearing six to eight weeks followed by weight-bearing cast. MRI follow-up if avascular necrosis is suspected. Active therapy with or without passive therapy.

(c). Return to work and restrictions after surgery may be made by an attending physician experienced in occupational medicine in consultation with the surgeon or by the surgeon.

q. Tarsal Tunnel Syndrome

i. Description: Pain and paresthesias along the medial aspect of the ankle and foot due to nerve irritation and entrapment of the tibial nerve or its branches. These symptoms can also be caused by radiculopathy.

ii. Occupational Relationship: Acute injuries may occur after blunt trauma along the medial aspect of the foot. Non-traumatic occurrences are determined at physician's discretion after review of environmental and biomechanical risk factors. Non work related causes include space occupying lesions.

iii. Specific Physical Exam Findings: Positive Tinel's sign. Pain with percussion of the tibial nerve radiating distally or proximally. Pain and paresthesias with weight-bearing activities.

iv. Diagnostic Testing Procedures: Nerve conduction velocity studies of both sides for comparison to normal side. EMGs may be needed to rule out radiculopathy. MRI to rule out space occupying lesions. Diagnostic injections to confirm the diagnosis.

## v. Non-operative Treatment Procedures:

(a). Initial Treatment: Cast or bracing, immobilization and foot orthoses are appropriate initial management.

(b). Medications such as analgesics and anti-inflammatories may be helpful. Refer to medication discussions in Medications and Medical Management.

(c). Patient education should include instruction in self-management techniques, ergonomics, body mechanics, home exercise, joint protection, and weight management.

(d). Return to work with appropriate restrictions should be considered early in the course of treatment.

(i). Orthotics or accommodative footwear is usually necessary before workers can be returned to walking on hard surfaces. Refer to Return to Work.

(e). Other therapies in Therapeutic Procedures, Non-operative may be employed in individual cases.

## vi. Surgical Indications/Considerations

(a). Continued functional deficits after active participation in therapy for three to six months.

(b). Prior to surgical intervention, the patient and treating physician should identify functional operative goals and the likelihood of achieving improved ability to perform activities of daily living or work activities and the patient should agree to comply with the pre- and post-operative treatment plan including home exercise. The provider should be especially careful to make sure the patient understands the amount of post-operative therapy required and the length of partial- and full-disability expected post-operatively.

(c). Smoking may affect soft tissue healing through tissue hypoxia. Patients should be strongly encouraged to stop smoking and be provided with appropriate counseling by the physician.

vii. Operative Procedures: Tarsal tunnel release with or without a plantar fascial release.

## viii. Post-Operative Treatment:

(a). An individualized rehabilitation program based upon communication between the surgeon and the therapist and using therapies as outlined in Therapeutic Procedures, Non-Operative.

(b). Treatment may include the following: restricted weight-bearing, orthotics, bracing, active therapy with or without passive therapy.

(c). Return to work and restrictions after surgery may be made by an attending physician experienced in occupational medicine in consultation with the surgeon or by the surgeon.

r. Tendonopathy: For Achilles Tendonopathy, Refer to Specific Lower Extremity Injury Diagnosis, Testing and Treatment for other types of tendonopathy of the foot and

ankle, General recommendations can be found in Tendonopathy of the Knee.

## 2. Knee

## a. Aggravated Osteoarthritis

i. Description/Definition: Swelling and/or pain in a joint due to an aggravating activity in a patient with pre-existing degenerative change in a joint. Age greater than 50 and morning stiffness lasting less than 30 minutes are frequently associated. The lifetime risk for symptomatic knee arthritis is probably around 45 percent and is higher among obese persons.

ii. Occupational Relationship: The provider must establish the occupational relationship by establishing a change in the patient's baseline condition and a relationship to work activities including but not limited to physical activities such as repetitive kneeling or crawling, squatting and climbing, or heavy lifting.

(a). Other causative factors to consider - Previous meniscus or ACL damage may predispose a joint to degenerative changes. In order to entertain previous trauma as a cause, the patient should have medical documentation of the following: meniscectomy; hemarthrosis at the time of the original injury; or evidence of MRI or arthroscopic meniscus or ACL damage. The prior injury should have been at least two years from the presentation for the new complaints and there should be a significant increase of pathology on the affected side in comparison to the original imaging or operative reports and/or the opposite un-injured side or extremity.

(b). Body mass index (BMI) of 25 or greater is a significant risk factor for eventual knee replacement.

iii. Specific Physical Exam Findings: Increased pain and/or swelling in a joint with joint line tenderness; joint crepitus; and/or joint deformity.

iv. Diagnostic Testing Procedures: Radiographs, The Kellgren-Lawrence Scale is the standard radiographic scale for knee osteoarthritis. It is based on the development of osteophytes, on bone sclerosis, and on joint space narrowing. The degree of joint space narrowing may not predict disability.

(a). Grade 1: doubtful narrowing of joint space, and possible osteophytic lipping.

(b). Grade 2: definite osteophytes, definite narrowing of joint space.

(c). Grade 3: moderate multiple osteophytes, definite narrowing of joint space, some sclerosis and possible deformity of bone contour.

(d). Grade 4: large osteophytes, marked narrowing of joint space, severe sclerosis and definite deformity of bone contour.

(e). MRI to rule out degenerative menisci tears. MRI may identify bone marrow lesions which are correlated

with knee pain. These lesions may reflect increased water, blood, or other fluid inside bone and may contribute to the causal pathway of pain. These are incidental findings and should not be used to determine a final diagnosis nor make decisions regarding surgery.

v. Non-Operative Treatment Procedures

(a). Medications such as analgesics and anti-inflammatories may be helpful. Refer to medication discussions in Medications and Medical Management.

(b). Patient education should include instruction in self-management techniques, ergonomics, body mechanics, home exercise, joint protection, and weight management. There is good evidence for self-management using weight loss, exercise, pacing of activities, unloading the joint with braces, insoles and possibly taping, and medications as needed. Patients should be encouraged to perform aerobic activity such as walking or biking. However, activities such as ladders, stairs and kneeling may be restricted.

(c). Benefits may be achieved through therapeutic rehabilitation and rehabilitation interventions. They should include range-of-motion (ROM), active therapies, and a home exercise program. Active therapies include, proprioception training, restoring normal joint mechanics, and clearing dysfunctions from distal to proximal structures. Passive as well as active therapies may be used for control of pain and swelling. Therapy should progress to strengthening and an independent home exercise program targeted to further improve ROM, strength, and normal joint mechanics influenced by structures distal and proximal to the knee. Bracing may be appropriate in some instances. Refer to Therapeutic Procedures, Non-operative. There is good evidence that there is a small functional advantage for patients involved in exercise with physical therapy supervision over home exercise.

(i). There is some evidence that active physical therapy improves knee function more effectively than medication alone.

(ii). Aquatic therapy may be used as a type of active intervention when land-based therapy is not well-tolerated.

(iii). Passive modalities are most effective as adjunctive treatments to improve the results of active treatment. They may be used as found in Therapeutic Procedures, Non-operative. There is some evidence that ice massage can improve ROM, strengthening of the knee and function. Ice can be used with proper instruction at home or under supervision for up to 20 minute periods 3 times per week or more frequently.

(d). Therapeutic Injections—both steroids and viscosupplementation may be used.

(i). There is good evidence that intra-articular corticosteroid injection is more effective than placebo in reducing pain from osteoarthritis. Optimum dosage is not known.

(ii). Steroid injections may decrease inflammation and allow the therapist to progress with functional exercise and ROM.

[a]. Time to Produce Effect: One injection.

[b]. Maximum Duration: Three injections in one year at least four to eight weeks apart.

(iii). Steroid injections should be used cautiously in diabetic patients. Diabetic patients should be reminded to check their blood glucose levels at least daily for two weeks after injections.

(iv). Viscosupplementation appears to have a longer lasting effect than intra-articular corticosteroids, however, the overall effect varies depending on the timing and the effect studied. Refer to Therapeutic Procedures.

(e). Return to work with appropriate restrictions should be considered early in the course of treatment. Refer to Return to Work.

(f). Other therapies in Therapeutic Procedures, Non-operative may be employed in individual cases.

(g). Bracing such as knee immobilizer or hinge brace may be used for acute ACL injuries.

vi. Surgical Indications/Considerations.

(a). Arthroscopic Debridement and/or Lavage. There is good evidence from a randomized controlled trial that arthroscopic debridement alone provides no benefit over recommended therapy for patients with uncomplicated Grade 2 or higher arthritis. The comparison recommended treatment in the study followed the American College of Rheumatology guidelines which includes: patient education, and supervised therapy with a home program, instruction on ADLs, stepwise use of analgesics and hyaluronic acid injections if desired. Complicated arthritic patients excluded from the study included patients who required other forms of intervention due to the following associated conditions: large meniscal bucket handle tears, inflammatory or infectious arthritis, more than 5 degrees of varus or valgus deformity, previous major knee trauma, or Grade 4 arthritis in two or more compartments.

(i). Therefore, arthroscopic debridement and/or lavage are not recommended for patients with arthritic findings and continual pain and functional deficits unless there is meniscal or cruciate pathology. Refer to the specific conditions in Specific Lower Extremity Injury Diagnosis, Testing and Treatment, for specific diagnostic recommendations.

(b). Osteotomy and joint replacement are indicated when conservative treatment, including active participation in non-operative treatment has failed to result in sufficient functional improvement (Refer to Knee Arthroplasty, and Osteotomy). Tibial osteotomy is a choice for younger patients with unicompartmental disease who have failed conservative therapy.

(c). In cases where surgery is contraindicated due to obesity, it may be appropriate to recommend a weight loss



program if the patient is unsuccessful losing weight on their own. Coverage for weight loss would continue only for motivated patients who have demonstrated continual progress with weight loss.

(d). Prior to surgical intervention, the patient and treating physician should identify functional operative goals and the likelihood of achieving improved ability to perform activities of daily living or work activities and the patient should agree to comply with the pre- and post-operative treatment plan including home exercise. The provider should be especially careful to make sure the patient understands the amount of post-operative therapy required and the length of partial- and full-disability expected post-operatively.

(e). Because smokers have a higher risk of non-union and post-operative costs, it is recommended that carriers cover a smoking cessation program peri-operatively. Physicians may monitor smoking cessation with laboratory tests such as cotinine levels for long-term cessation.

vii. Operative Procedures: Total or compartmental joint replacement, and osteotomy.

(a). Free-floating interpositional unicompartmental replacement is not recommended for any patients due to high revision rate at two years and less than optimal pain relief.

viii. Post-Operative Treatment

(a). An individualized rehabilitation program based upon communication between the surgeon and therapist and using the treatments found in Therapeutic Procedures, Non-operative. In all cases, communication between the physician and therapist is important to the timing of weight-bearing and exercise progressions.

(b). Refer also to Knee Arthroplasty, or Osteotomy as appropriate.

(c). Return to work and restrictions after surgery may be made by an attending physician experienced in occupational medicine in consultation with the surgeon or by the surgeon.

b. Anterior Cruciate Ligament (ACL) Injury

i. Description/Definition: Rupture or partial rupture of the anterior cruciate ligament; may be associated with other internal derangement of the knee.

ii. Occupational Relationship: May be caused by virtually any traumatic force to the knee but most often caused by a twisting or a hyperextension force, with a valgus stress. The foot is usually planted and the patient frequently experiences a “popping” feeling.

iii. Specific Physical Exam Findings: Findings on physical exam include effusion or hemarthrosis, instability, positive Lachman’s test, positive pivot shift test, and positive anterior drawer test.

iv. Diagnostic Testing Procedures: MRI. Radiographs may show avulsed portion of tibial spine but this is a rare finding.

v. Non-operative Treatment Procedures:

(a). Initial Treatment: Acute injuries may require immobilization followed by active therapy with or without passive therapy.

(b). Medications such as analgesics and anti-inflammatories may be helpful. Refer to Medications and Medical Management.

(c). Patient education should include instruction in self-management techniques, ergonomics, body mechanics, home exercise, joint protection, and weight management.

(d). Benefits may be achieved through therapeutic rehabilitation and rehabilitation interventions. They should include range-of-motion (ROM), active therapies, and a home exercise program. Active therapies include proprioception training, restoring normal joint mechanics, and clearing dysfunctions from distal and proximal structures bracing may be beneficial. Passive as well as active therapies may be used for control of pain and swelling. Therapy should progress to strengthening and an independent home exercise program targeted to further improve ROM, strength, and normal joint mechanics influenced by structures distal and proximal to the knee (Refer to Therapeutic Procedures, Non-operative). Passive modalities are most effective as adjunctive treatments to improve the results of active treatment. They may be used as found in Therapeutic Procedures, Non-operative.

(i). There is no evidence that any particular exercise regime is better for ACL injuries in combination with collateral or meniscus injuries. There is no evidence that knee bracing for non operated ACL improves outcomes although patients may feel that they have greater stability. Non surgical treatment may provide acceptable results in some patients.

(e). Return to work with appropriate restrictions should be considered early in the course of treatment. Refer to Return to Work.

(f). Other therapies in Therapeutic Procedures, Non-operative may be employed in individual cases.

iv. Surgical Indications/Considerations: any individual with complaints of recurrent instability interfering with function and physical findings with imaging consistent with an ACL injury.

(a). Prior to surgical intervention, the patient and treating physician should identify functional operative goals and the likelihood of achieving improved ability to perform activities of daily living or work activities and the patient should agree to comply with the pre- and post-operative treatment plan including home exercise. The provider should be especially careful to make sure the patient understands the amount of post-operative therapy required and the length of partial- and full-disability expected post-operatively.

(b). Smoking may affect soft tissue healing through tissue hypoxia. Patients should be strongly

encouraged to stop smoking and be provided with appropriate counseling by the physician.

v. Operative Procedures

(a). Diagnostic/surgical arthroscopy followed by ACL reconstruction using autograft or allograft. If meniscus repair is performed, an ACL repair should be performed concurrently.

(b). Patients tend to have more pain associated with patellar grafts while patients with hamstring replacement seem to have an easier rehabilitation. Choice of graft is made by the surgeon and patient on an individual basis.

vi. Post-Operative Treatment

(a). An individualized rehabilitation program based upon communication between the surgeon and the therapist and using therapies as outlined in Therapeutic Procedures, Non-operative.

(b). Treatment may include the following: active therapy with or without passive therapy and bracing. Early active extension does not cause increased laxity at two years.

(c). Return to work and restrictions after surgery may be made by an attending physician experienced in occupational medicine in consultation with the surgeon or by the surgeon.

c. Bursitis of the Lower Extremity

i. Description/Definition: Inflammation of bursa tissue. Bursitis can be precipitated by tendonitis, bone spurs, foreign bodies, gout, arthritis, muscle tears, or infection.

ii. Occupational Relationship: Soft tissue trauma, contusion, or physical activities of the job such as sustained direct compression force, or other repetitive forceful activities affecting the knee.

iii. Specific Physical Exam Findings: Palpable, tender and enlarged bursa, decreased ROM, warmth. The patient may have increased pain with ROM.

iv. Diagnostic Testing Procedures: Lab work may be done to rule out inflammatory disease. Bursal fluid aspiration with testing for connective tissue, rheumatic disease, and infection may be necessary. Radiographs, CT, MRI are rarely indicated.

v. Non-operative Treatment Procedures

(a). Initial Treatment: Diagnostic/therapeutic aspiration, ice, therapeutic injection, treatment of an underlying infection, if present. Aspirations may be repeated as clinically indicated.

(b). Medications such as analgesics and anti-inflammatories may be helpful. Refer to medication discussions in Medications and Medical Management.

(c). Patient education should include instruction in self-management techniques, ergonomics, body mechanics, home exercise, joint protection, and weight management.

(d). Benefits may be achieved through therapeutic rehabilitation and rehabilitation interventions. They should include range-of-motion (ROM), active therapies, including a home exercise program. Active therapies include, proprioception training, restoring normal joint mechanics, and clearing dysfunctions from distal and proximal joints. Passive as well as active therapies may be used for control of pain and swelling. Therapy should progress to strengthening and an independent home exercise program targeted to further improve ROM, strength, and normal joint mechanics influenced by structures distal and proximal to the knee. Refer to Therapeutic Procedures, Non-operative.

(i). Passive modalities are most effective as adjunctive treatments to improve the results of active treatment. They may be used as found as adjunctive in Therapeutic Procedures, Non-operative.

(e). Steroid Injections. Steroid injections may decrease inflammation and allow the therapist to progress with functional exercise and ROM.

(i). Time to Produce Effect: One injection.

(ii). Maximum Duration: Three injections in one year spaced at least four to eight weeks apart.

(iii). Steroid injections should be used cautiously in diabetic patients. Diabetic patients should be reminded to check their blood glucose levels at least daily for two weeks after injections.

(f). Return to work with appropriate restrictions should be considered early in the course of treatment. Refer to Return to Work.

(g). Other therapies in Therapeutic Procedures, Non-operative may be employed in individual cases.

vi. Surgical indications/Considerations:

(a). Failure of conservative therapy.

(b). Prior to surgical intervention, the patient and treating physician should identify functional operative goals and the likelihood of achieving improved ability to perform activities of daily living or work activities and the patient should agree to comply with the pre- and post-operative treatment plan including home exercise. The provider should be especially careful to make sure the patient understands the amount of post-operative therapy required and the length of partial- and full-disability expected post-operatively.

(c). Smoking may affect soft tissue healing through tissue hypoxia. Patients should be strongly encouraged to stop smoking and be provided with appropriate counseling by the physician.

vii. Operative Procedures: Surgical excision of the bursa.

viii. Post-Operative Treatment

(a). An individualized rehabilitation program based upon communication between the surgeon and the

therapist and using the therapies as outlined in Therapeutic Procedures, Non-operative.

(b). Return to work and restrictions after surgery may be made by an attending physician experienced in occupational medicine in consultation with the surgeon or by the surgeon.

d. Chondral and Osteochondral Defects

i. Description/Definition: Cartilage or cartilage and bone defect at the articular surface of a joint. Deficits may be identified in up to 60 percent of arthroscopies; however, only around 30 percent of these lesions are isolated deficits and even fewer are Grade III or IV deficits which might qualify for cartilage grafts.

(a). Defects in cartilage and bone are common at the femoral condyles and patella. The Outerbridge classification grades these defects according to their size and depth.

(i). Grade 0: normal cartilage.

(ii). Grade I: softening and swelling of cartilage.

(iii). Grade II: partial-thickness defects with surface fissures that do not exceed 1.5 cm in diameter and do not reach subchondral bone.

(iv). Grade III: fissuring that reaches subchondral bone in an area with a diameter greater than 1.5 cm.

(v). Grade IV: exposed subchondral bone.

ii. Occupational Relationship: Typically caused by a traumatic knee injury. Chondral deficits can also be present secondary to osteoarthritis.

iii. Specific Physical Exam Findings: Knee effusion, joint line tenderness.

iv. Diagnostic Testing Procedures: MRI may show bone bruising, osteochondral lesion, or possibly articular cartilage injury. Radiographs, contrast radiography, CT may also be used. Diagnostic arthroscopy may be performed when surgical indications as stated in Section VI are met.

v. Non-Operative Treatment Procedures:

(a). Initial Treatment: Non-operative treatment may be indicated for chondral lesions associated with degenerative changes, refer to aggravated osteoarthritis; other knee lesions not requiring surgery (refer to Specific Diagnosis); and/or non-displaced stable lesions. Acute injuries may require immobilization followed by active therapy with or without passive therapy.

(b). Medications such as analgesics and anti-inflammatories may be helpful. Refer to medication discussions in Medications and Medical Management.

(c). Patient education should include instruction in self-management techniques, ergonomics, body mechanics, home exercise, joint protection, and weight management.

(d). Benefits may be achieved through therapeutic rehabilitation and rehabilitation interventions. They should include range-of-motion (ROM), active therapies, and a home exercise program. Active therapies include, proprioception training, restoring normal joint mechanics, and clearing dysfunctions from distal and proximal structures. Passive as well as active therapies may be used for control of pain and swelling. Therapy should progress to strengthening and an independent home exercise program targeted to further improve ROM, strength, and normal joint mechanics influenced by structures distal and proximal to the knee. Refer to Therapeutic Procedures, Non-operative.

(i). Passive modalities are most effective as adjunctive treatments to improve the results of active treatment. They may be used as found in Therapeutic Procedures, Non-operative.

(e). Return to work with appropriate restrictions should be considered early in the course of treatment. Refer to Return to Work.

(f). Other therapies in Therapeutic Procedures, Non-operative may be employed in individual cases.

vi. Surgical Indications/Considerations: Surgery for isolated chondral defects may be indicated when functional deficits interfere with activities of daily living and/or job duties after 6 to 12 weeks of active patient participation in non-operative therapy. Identification of the lesion should have been accomplished by diagnostic testing procedures which describe the size of the lesion and stability of the joint. If a lesion is detached or has fluid underlying the bone on MRI, surgery may be necessary before a trial of conservative therapy is completed. Early surgery may consist of fixation or microfracture.

(a). Microfractures: Normally the first line of surgical treatment.

(i). Indications: An isolated small full-thickness articular chondral defect with normal joint space, when the patient has not recovered functionally after active participation in therapy. Patients 45 or younger are likely to have better results.

(b). Osteochondral Autograft Transfer System (OATS)

(i). Indications: The knee must be stable with intact ligaments and menisci, normal joint space and a large full-thickness defect less than 3 square cm and 1 cm depth. They should be 45 or younger, with a BMI less than 35, and engaged in athletics and/or an equally physically demanding occupation. Surgery may be indicated when functional deficits interfere with activities of daily living and/or job duties after 6 to 12 weeks of active patient participation in non-operative therapy. This procedure may be appropriate in a small subset of patients.

(c). Autologous chondrocyte implantation (ACI): These procedures are technically difficult and require specific physician expertise. Cartilage transplantation

requires the harvesting and growth of patients' cartilage cells in a highly specialized lab and incurs significant laboratory charges. There is some evidence that transplants and microfractures do not differ on long-term effects. There is some evidence that autologous chondrocyte implantation is not better than microfracture five years after surgery in patients younger than 45 presenting with Grade III -IV lesions. This procedure is controversial but may be appropriate in a small subset of patients with physically rigorous employment or recreational activities. It requires prior authorization.

(i). Indications: The area of the lesion should be between 2 square cm and 10 square cm. The patient should have failed four or more months of active participation in therapy and a microfracture, abrasion, arthroplasty or drilling with sufficient healing time, which may be from four months to over one year. The knee must be stable with intact ligaments and meniscus, and normal joint space. Patients should be 45 or younger, with a BMI less than 35, and engaged in athletics and/or an equally physically demanding occupation.

(d). Contraindications: General contraindications for grafts and transplants are individuals with obesity, inflammatory or osteoarthritis with multiple chondral defects, associated ligamentous or meniscus pathology, or who are older than 55 years of age.

(e). Prior to either graft or implantation intervention the patient and treating physician should identify functional operative goals and the likelihood of achieving improved ability to perform activities of daily living or work activities and the patient should agree to comply with the pre- and post-operative treatment plan including home exercise. The provider should be especially careful to make sure the patient understands the amount of post-operative therapy required and the length of partial- and full-disability expected post-operatively.

(f). Smoking may affect soft tissue healing through tissue hypoxia. Patients should be strongly encouraged to stop smoking and be provided with appropriate counseling by the physician.

vii. Operative Procedures: Arthroscopy with debridement or shaving of cartilage, microfracture, drilling, abrasion arthroplasty, mosaicplasty or osteochondral autograft (OATS), fixation of loose osteochondral fragments and autologous chondrocyte implantation (ACI).

(a). Radiofrequency treatment is not recommended.

viii. Post-Operative Treatment

(a). An individualized rehabilitation program based upon communication between the surgeon and the therapist and using therapies as outlined in Therapeutic Procedures, Non-operative. In all cases, communication between the physician and therapist is important to the timing of weight-bearing and exercise progressions.

(b). Treatment may include the following: restricted weight-bearing, bracing, active therapy with or without passive therapy. Full weight-bearing usually occurs by or before 8 weeks.

(c). Continuous passive motion may be used after chondral procedures.

(d). Return to work and restrictions after surgery may be made by an attending physician experienced in occupational medicine in consultation with the surgeon or by the surgeon. Return to full-duty usually occurs by between four and six months.

(e). Collateral Ligament Pathology

(i). Description/Definition: Strain or tear of medial or lateral collateral ligaments which provide some stabilization for the knee.

(ii). Occupational Relationship: Typically a result of forced abduction and external rotation to an extended or slightly flexed knee.

(iii). Specific Physical Exam Findings: Swelling or ecchymosis over the collateral ligaments and increased laxity or pain with applied stress.

(iv). Diagnostic Testing Procedures: X-rays to rule out fracture. Imaging is more commonly ordered when internal derangement is suspected.

(v). Non-Operative Treatment Procedures

[a]. Initial Treatment: braces, ice, and protected weight-bearing.

[b]. Medications such as analgesics and anti-inflammatories may be helpful. Refer to medication discussions area in Medications and Medical Management.

[c]. Patient education should include instruction in self-management techniques, ergonomics, body mechanics, home exercise, joint protection, and weight management.

[d]. Benefits may be achieved through therapeutic rehabilitation and rehabilitation interventions. They should include range-of-motion (ROM), active therapies, and a home exercise program. Active therapies include proprioception training, restoring normal joint mechanics, and clearing dysfunctions from distal and proximal structures. Bracing may be beneficial. Passive as well as active therapies may be used for control of pain and swelling. Therapy should progress to strengthening and an independent home exercise program targeted to further improve ROM, strength, and normal joint mechanics influenced by structures distal and proximal to the knee. Refer to Therapeutic Procedures, Non-operative.

[i]. Passive modalities are most effective as adjunctive treatments to improve the results of active treatment. They may be used as found in Therapeutic Procedures, Non-operative.

[e]. Return to work with appropriate restrictions should be considered early in the course of treatment. Refer to Return to Work.

[f]. Other therapies in Therapeutic Procedures, Non-operative may be employed in individual cases.

ix. Surgical Indications/Considerations: Surgery is rarely necessary except when functional instability persists after active participation in non-operative treatment or indications for surgery exist due to other accompanying injuries.

(a). Prior to surgical intervention, the patient and treating physician should identify functional operative goals and the likelihood of achieving improved ability to perform activities of daily living or work activities and the patient should agree to comply with the pre- and post-operative treatment plan including home exercise. The provider should be especially careful to make sure the patient understands the amount of post-operative therapy required and the length of partial- and full-disability expected post-operatively.

(b). Smoking may affect soft tissue healing through tissue hypoxia. Patients should be strongly encouraged to stop smoking and be provided with appropriate counseling by the physician.

x. Operative Procedures: surgical repair.

xi. Post-Operative Treatment

(a). An individualized rehabilitation program based upon communication between the surgeon and the therapist and using procedures as outlined in Therapeutic Procedures, Non-Operative.

(b). Return to work and restrictions after surgery may be made by an attending physician experienced in occupational medicine in consultation with the surgeon or by the surgeon.

f. Meniscus Injury

i. Description/Definition—a tear, disruption, or avulsion of medial or lateral meniscus tissue. Locking of the knee or clicking is frequently reported. Patients may describe a popping, tearing, or catching sensation followed by stiffness.

ii. Occupational Relationship—trauma to the menisci from rotational shearing, torsion, and/or impact injuries while in a flexed position.

iii. Specific Physical Exam Findings: Joint line tenderness, Positive McMurray's test locked joint, or occasionally, effusion. The presence of joint line tenderness has a sensitivity of 85 percent and a specificity of 31 percent. The Apley's compression test is also used.

iv. Diagnostic Testing Procedures. Radiographs including standing Posterior/Anterior (PA), lateral, tunnel, and skyline views. MRI is the definitive imaging test. MRI is sensitive and specific for meniscal tear. However, meniscal MRI is frequently abnormal in asymptomatic

injuries. In one study of volunteers without a history of knee pain, swelling, locking, giving way, or any knee injury, 16 percent of the volunteers had MRI-evident meniscal tears; among volunteers older than 45, 36 percent had MRI-evident meniscal tears. Therefore, clinical correlation with history and physical exam findings specific for meniscus injury is critically important.

(a). Providers planning treatment should therefore consider the patient's complaints and presence of arthritis on MRI carefully, knowing that not all meniscus tears in the middle aged and older population are related to the patients' complaints of pain.

(b). MRI arthrograms are used to diagnose recurrent meniscal tears particularly after previous surgery.

v. Non-Operative Treatment

(a). Initial Treatment: ice, bracing, and protected weight-bearing.

(b). Medications such as analgesics and anti-inflammatories may be helpful. Refer to medication discussions in Medications and Medical Management.

(c). Patient education should include instruction in self-management techniques, ergonomics, body mechanics, home exercise, joint protection, and weight management.

(d). Benefits may be achieved through therapeutic rehabilitation and rehabilitation interventions. They should include range-of-motion (ROM), active therapies, and a home exercise program. Active therapies include, proprioception training, restoring normal joint mechanics, and clearing dysfunctions from distal and proximal structures. Passive as well as active therapies may be used for control of pain and swelling. Therapy should progress to strengthening and an independent home exercise program targeted to further improve ROM, strength, and normal joint mechanics influenced by structures distal and proximal to the knee. Refer to Therapeutic Procedures, Non-operative.

(i). Passive modalities are most effective as adjunctive treatments to improve the results of active treatment. They may be used as found as adjunctive in Therapeutic Procedures, Non-Operative.

(e). Return to work with appropriate restrictions should be considered early in the course of treatment. Refer to Return to Work.

(f). Other therapies in Therapeutic Procedures, Non-operative may be employed in individual cases.

vi. Surgical Indications/Considerations: Locked or blocked knee precluding active therapy; Isolated acute meniscus tear with appropriate physical exam findings; Meniscus pathology combined with osteoarthritis in a patient with functional deficits interfering with activities of daily living and/or job duties after 6 to 12 weeks of active patient participation in non-operative therapy.

(a). It is not clear that partial meniscectomy for a chronic degenerative meniscal tear is beneficial. Middle aged patients may do as well without arthroscopy and with therapy.

(b). Meniscal allograft should only be performed on patients between 20 and 45 with an otherwise stable knee, previous meniscectomy with 2/3 removed, lack of function despite active therapy, BMI less than 35, and sufficient joint surface to support repair.

(c). Medial collagen meniscus implants are considered experimental and not generally recommended. No studies have been done to compare this procedure to medial meniscus repair. There is some evidence to support the fact that collagen meniscal implant may slightly improve function and decrease risk of reoperation in patients with previous medial meniscal surgery. It remains unclear as to the extent that the procedure may decrease future degenerative disease. The procedure can only be considered for individuals with previous medial meniscal surgery and intact meniscus rim; without lateral meniscus lesions or Grade 4 Outerbridge lesions; and who need to return to heavy physical labor employment or demanding recreational activities. A second concurring opinion from an orthopedic surgeon specializing in knee surgery and prior authorization is required. Full weight-bearing is not allowed for 6 weeks and most patients return to normal daily activity after three months.

(d). Prior to surgical intervention, the patient and treating physician should identify functional operative goals and the likelihood of achieving improved ability to perform activities of daily living or work activities and the patient should agree to comply with the pre- and post-operative treatment plan including home exercise. The provider should be especially careful to make sure the patient understands the amount of post-operative therapy required and the length of partial- and full-disability expected post-operatively.

(e). Smoking may affect soft tissue healing through tissue hypoxia. Patients should be strongly encouraged to stop smoking and be provided with appropriate counseling by the physician.

vii. Operative Treatment: Repair of meniscus, partial or complete excision of meniscus or meniscus allograft or implant. Debridement of the meniscus is not recommended in patients with severe arthritis as it is unlikely to alleviate symptoms. Complete excision of meniscus should only be performed when clearly indicated due to the long-term risk of arthritis in these patients. Partial meniscectomy or meniscus repair is preferred to total meniscectomy due to easier recovery, less instability, and short-term functional gains.

#### viii. Post-Operative Treatment

(a). An individualized rehabilitation program based upon communication between the surgeon and the therapist using the treatments found in Therapeutic Procedures, Non-operative.

(b). Treatment may include the following: Passive therapy progressively moving toward active therapy, bracing, cryotherapy and other treatments found in Therapeutic procedures Non-Operative.

(c). Return to work and restrictions after surgery may be made by an attending physician experienced in occupational medicine in consultation with the surgeon or by the surgeon.

#### g. Patellar Fracture

i. Description/Definition: Fracture of the patella.

ii. Occupational Relationship: Usually from a traumatic injury such as a fall or direct blow

iii. Specific Physical Exam Findings: Significant hemarthrosis/effusion usually present. Extension may be limited and may indicate disruption of the extensor mechanism. It is essential to rule out open fractures; therefore a thorough search for lacerations is important.

iv. Diagnostic Testing Procedures. Aspiration of the joint and injection of local anesthetic may aid the diagnosis. A saline load injected in the joint can also help rule out an open joint injury. Radiographs may be performed, including tangential (sunrise) or axial views and x-ray of the opposite knee in many cases. CT or MRI is rarely needed.

#### v. Non-Operative Treatment Procedures

(a). Initial Treatment: For non-displaced closed fractures, protected weight-bearing and splinting for four to six weeks. Hinged knee braces can be used. When radiographs demonstrate consolidation, active motion and strengthening exercise may begin.

(b). Medications such as analgesics and anti-inflammatories may be helpful. Refer to medication discussions in Medications and Medical Management.

(c). Patient education should include instruction in self-management techniques, ergonomics, body mechanics, home exercise, joint protection, and weight management.

(d). Refer to comments related to osteoporosis in Therapeutic Procedures, Non-operative, Osteoporosis Management.

(e). Smoking may affect fracture healing. Patients should be strongly encouraged to stop smoking and be provided with appropriate counseling by the physician.

(f). Benefits may be achieved through therapeutic rehabilitation and rehabilitation interventions, after bony union has been achieved. They should include bracing then range-of-motion (ROM), active therapies including proprioception training, restoring normal joint mechanics, and clearing dysfunctions from adjacent structures, and a home exercise program. Passive as well as active therapies may be used for control of pain and swelling. Therapy should progress to strengthening and an independent home exercise program targeted to further

improve ROM, strength, restoring normal joint mechanics, influenced by proximal and distal structures. Therapy should include training on the use of adaptive equipment and home and work site evaluations when appropriate. Bracing may be appropriate. Refer to Therapeutic Procedures, Non-operative.

(i). Passive modalities are most effective as adjunctive treatments to improve the results of active treatment. They may be used as found as adjunctive in Therapeutic Procedures, Non-operative.

(g). Return to work with appropriate restrictions should be considered early in the course of treatment. Refer to Return to Work.

(h). Other therapies in Therapeutic Procedures, Non-operative may be employed in individual cases

vi. Surgical Indications/Considerations: Open fractures require immediate intervention and may need repeat debridement. Internal fixation is usually required for comminuted or displaced fractures. Non-union may also require surgery.

(a). Because smokers have a higher risk of non-union and post-operative costs, it is recommended that insurers cover a smoking cessation program peri-operatively. Physicians may monitor smoking cessation with laboratory tests such as cotinine levels for long-term cessation.

vii. Operative Procedures: internal fixation; partial patellectomy or total patellectomy. Total patellectomy results in instability with running or stairs and significant loss of extensor strength. Therefore, this is usually a salvage procedure.

#### viii. Post-Operative Treatment

(a). An individualized rehabilitation program based upon communication between the surgeon and the therapist and using therapies as outlined in Therapeutic Procedures, Non-operative. In all cases, communication between the physician and therapist is important to the timing of weight-bearing and exercise progressions. Continuous passive motion may be used post operatively.

(b). Treatment may include protected weight-bearing and active therapy with or without passive therapy for early range of motion if joint involvement.

(c). Return to work and restrictions after surgery may be made by an attending physician experienced in occupational medicine in consultation with the surgeon or by the surgeon.

(d). Hardware removal may be necessary after three to six months.

#### h. Patellar Subluxation:

i. Description/Definition: Incomplete subluxation or dislocation of the patella. Recurrent episodes can lead to subluxation syndrome that can cause frank dislocation of the patella. Patient may report a buckling sensation, pain with extension, or a locking of the knee with exertion.

ii. Occupational Relationship: Primarily associated with a direct contact lateral force. Secondary causes associated with shearing forces on the patella.

iii. Specific Physical Exam Findings: Lateral retinacular tightness with associated medial retinacular weakness, swelling, effusion, and marked pain with patellofemoral tracking/compression and glides. In addition, other findings may include atrophy of muscles, positive patellar apprehension test, and patella alta.

iv. Diagnostic Testing Procedures: CT or Radiographs including Merchant views, Q-angle, and MRI for loose bodies.

#### v. Non-Operative Treatment Procedures

(a). Initial Treatment: Reduction if necessary, ice, taping, and bracing followed by active therapy.

(b). Medications such as analgesics and anti-inflammatories may be helpful. Refer to medication discussions in Medications and Medical Management.

(c). Patient education should include instruction in self-management techniques, ergonomics, body mechanics, home exercise, joint protection, and weight management.

(d). Benefits may be achieved through therapeutic rehabilitation and rehabilitation interventions. They should include range-of-motion (ROM), active therapies, and a home exercise program. Active therapies include, proprioception training, restoring normal joint mechanics, and clearing dysfunctions from distal and proximal structures. Taping the patella or bracing may be beneficial. Passive as well as active therapies can be used for control of pain and swelling. Therapy should progress to strengthening and an independent home exercise program targeted to further improve ROM, strength, and normal joint mechanics influenced by structures distal and proximal to the knee. Specific strengthening should be done to optimize patellofemoral mechanics and address distal foot mechanics that influence the patellofemoral joint. Refer to Therapeutic Procedures, Non-operative.

(i). Passive modalities are most effective as adjunctive treatments to improve the results of active treatment. They may be used as found in Therapeutic Procedures, Non-operative.

(e). Return to work with appropriate restrictions should be considered early in the course of treatment. Refer to Return to Work.

(f). Other therapies in Therapeutic Procedures, Non-operative may be employed in individual cases.

#### vi. Surgical Indications/Considerations

(a). Fracture, loose bodies, and recurrent dislocation. Surgical repair of first-time dislocation in young adults generally is not recommended. Retinacular release, quadriceps reefing, and patellar tendon transfer should only be considered for subluxation after four to six months of active patient participation in non-operative treatment.

(b). Prior to surgical intervention, the patient and treating physician should identify functional operative goals and the likelihood of achieving improved ability to perform activities of daily living or work activities and the patient should agree to comply with the pre- and post-operative treatment plan including home exercise. The provider should be especially careful to make sure the patient understands the amount of post-operative therapy required and the length of partial- and full-disability expected post-operatively.

(c). Smoking may affect soft tissue healing through tissue hypoxia. Patients should be strongly encouraged to stop smoking and be provided with appropriate counseling by the physician.

vii. Operative Procedures: arthroscopy with possible arthrotomy; debridement of soft tissue and articular cartilage disruption; open reduction internal fixation with fracture; retinacular release, quadriceps reefing, and patellar tendon or lateral release with or without medial soft-tissue realignment.

viii. Post-Operative Treatment

(a). Individualized rehabilitation program based upon communication between the surgeon and the therapist using the treatments found in Therapeutic Procedures, Non-operative.

(b). Treatment may include active therapy with or without passive therapy, bracing.

(c). Return to work and restrictions after surgery may be made by an attending physician experienced in occupational medicine in consultation with the surgeon or by the surgeon.

i. Patellofemoral Pain Syndrome (aka Retropatellar Pain Syndrome)

i. Description/Definition. Patellofemoral pathologies are associated with resultant weakening, instability, and pain of the patellofemoral mechanism. Diagnoses can include patellofemoral chondromalacia, malalignment, persistent quadriceps tendonitis, distal patellar tendonitis, patellofemoral arthrosis, and symptomatic plica syndrome. Patient complains of pain, instability and tenderness that interfere with daily living and work functions such as sitting with bent knees, climbing stairs, squatting, running or cycling.

ii. Occupational Relationship: Usually associated with contusion; repetitive patellar compressive forces; shearing articular injuries associated with subluxation or dislocation of patella, fractures, and/or infection.

iii. Specific Physical Exam Findings: Findings on physical exam may include retinacular tenderness, pain with patellar compressive ranging, positive patellar glide test, atrophy of quadriceps muscles, positive patellar apprehensive test. Associated anatomical findings may include increased Q angle; ligament laxity, and effusion. Some studies suggest that the patellar tilt test (assessing the patella for medial tilt) and looking for active instability with the patient supine and knee flexed to 15 degrees and an

isometric quad contraction, may be most useful for distinguishing normal from abnormal. Most patellar tests are more specific than sensitive.

iv. Diagnostic Testing Procedures: Radiographs including tunnel view, axial view of patella at 30 degrees, lateral view and Merchant views. MRI rarely identifies pathology. Occasional CT or bone scans.

v. Non-Operative Treatment Procedures

(a). Medications such as analgesics and anti-inflammatories may be helpful. Refer to medication discussions in Medications and Medical Management.

(b). Patient education should include instruction in self-management techniques, ergonomics, body mechanics, home exercise, joint protection, and weight management.

(c). Benefits may be achieved through therapeutic rehabilitation and rehabilitation interventions. The program should include bracing and/or patellar taping, prone quad stretches, hip external rotation, balanced strengthening, range-of-motion (ROM), active therapies and a home exercise program. Active therapies include proprioception training, restoring normal joint mechanics, and clearing dysfunctions from distal and proximal structures. Passive as well as active therapies may be used for control of pain and swelling. Active therapeutic exercise appears to decrease pain; however, the expected functional benefits are unclear. Therapy should progress to strengthening and an independent home exercise program targeted to further improve ROM strength, and normal joint mechanics influenced by structures distal and proximal to the knee. Refer to Therapeutic Procedures, Non-operative.

(i). Passive modalities are most effective as adjunctive treatments to improve the results of active treatment. They may be used as found as adjunctive in Section F., Therapeutic Procedures, Non-operative. Orthotics may be useful in some cases.

(d). Knee pain, when associated with abnormal foot mechanics, may be favorably treated with appropriate orthotics.

(i). There is some evidence that pre-fabricated commercially available foot orthotic devices are more beneficial for patients with patellofemoral pain syndrome than flat shoe inserts. They may produce mild side effects such as rubbing or blistering which can be reduced with additional empirical measures such as heat molding or addition, and removal of wedges and inserts until patient comfort is achieved. In some cases, custom semi-rigid or rigid orthotics is necessary to decrease pronation or ensure a proper fit. There is no evidence regarding which orthotic design might be useful.

(e). Botulinum toxin injections for the relief of patellofemoral pain are considered experimental and are not recommended.

(f). Steroid Injections



(i). Steroid injections may decrease inflammation and allow the therapist to progress with functional exercise and ROM. Steroid injections under significant pressure should be avoided as the needle may be penetrating the tendon and injection into the tendon can cause possible tendon breakdown, tendon degeneration, or rupture. Injections near the patellar tendon should generally be avoided. Injections should be minimized for patients less than 30 years of age.

[a]. Time to Produce Effect: One injection.

[b]. Maximum Duration: Three injections in one year spaced at least four to eight weeks apart.

(ii). Steroid injections should be used cautiously in diabetic patients. Diabetic patients should be reminded to check their blood glucose levels at least daily for two weeks after injections.

(g). Extracorporeal Shock Wave Therapy (ESWT): There is no good research to support ESWT and therefore, it is not recommended.

(h). Return to work with appropriate restrictions should be considered early in the course of treatment. Refer to Return to Work.

(i). Other therapies in Therapeutic Procedures, Non-operative may be employed in individual cases.

vi. Surgical Indications/Considerations: patellar tendon disruption, quadriceps tendon rupture/avulsion, fracture. There is no evidence that surgery is better than eccentric training for patellar tendonopathy of the inferior pole (jumper's knee).

(a). Retinacular release, quadriceps reefing, and tibial transfer procedures should only be considered after four to six months of active patient participation in non-operative treatment in young active patients. There is no evidence that arthroscopy for patellofemoral syndrome is more efficacious than exercise.

(b). Lateral release and reconstruction is not recommended for patellofemoral arthritis or middle aged adults.

(c). In cases of severe Grade III-IV isolated patellofemoral arthritis where walking, steps, and other functional activities are significantly impacted after adequate conservative treatment, prosthesis may be considered in those less than 55 years. A patellofemoral arthroplasty is generally contraindicated if there is patellofemoral instability or malalignment, tibiofemoral mechanical malalignment, fixed loss of knee motion (greater than 10 degrees extension or less than 110 degrees flexion), inflammatory arthritis, and other systemic related issues. For patellar resurfacing, refer to Knee Arthroplasty.

(d). Prior to surgical intervention, the patient and treating physician should identify functional operative goals and the likelihood of achieving improved ability to perform activities of daily living or work activities and the patient should agree to comply with the pre- and post-operative

treatment plan including home exercise. The provider should be especially careful to make sure the patient understands the amount of post-operative therapy required and the length of partial- and full-disability expected post-operatively.

(e). Smoking may affect soft tissue healing through tissue hypoxia. Patients should be strongly encouraged to stop smoking and be provided with appropriate counseling by the physician.

vii Operative Procedures: Arthroscopic debridement of articular surface, plica, synovial tissue, loose bodies; arthrotomy; open reduction internal fixation with fracture; patellar prosthesis with isolated Grade III-IV OA, and possible patellectomy for young active patients with isolated arthritis.

viii. Post-Operative Treatment

(a). An individualized rehabilitation program based upon communication between the surgeon and the therapist and using therapies as outlined in Therapeutic Procedures, Non-operative.

(b). Treatment may include active therapy with or without passive therapy; and bracing.

(c). Return to work and restrictions after surgery may be made by an attending physician experienced in occupational medicine in consultation with the surgeon or by the surgeon.

j. Posterior Cruciate Ligament (PCL) Injury

i. Description/Definition: Rupture of PCL. May be associated with concurrent ACL rupture or collateral ligament injury.

ii. Occupational Relationship. Most often caused by a posterior force directed to flexed knee.

iii. Specific Physical Exam Findings: Findings on physical exam include acute effusion, instability, reverse Lachman's test, reverse pivot shift, posterior drawer test.

iv. Diagnostic Testing Procedures: MRI, radiographs including kneeling view, may reveal avulsed bone.

v. Non-operative Treatment Procedures:

(a). Initial Treatment: Ice, bracing, and protected weight-bearing followed by active therapy.

(b). Medications such as analgesics and anti-inflammatories may be helpful. Refer to medication discussions in Medications and Medical Management.

(c). Patient education should include instruction in self-management techniques, ergonomics, body mechanics, home exercise, joint protection, and weight management.

(d). Benefits may be achieved through therapeutic rehabilitation and rehabilitation interventions. They should include bracing then range-of-motion (ROM), active therapies, and a home exercise program. Active therapies include proprioception training, restoring normal

joint mechanics, and clearing dysfunctions from distal and proximal structures. Passive as well as active therapies may be used for control of pain and swelling. Therapy should progress to strengthening and an independent home exercise program targeted to further improve ROM, strength, and normal joint structures distal and proximal to the knee. Refer to Therapeutic Procedures, Non-operative.

(i). Passive modalities are most effective as adjunctive treatments to improve the results of active treatment. They may be used as found in Therapeutic Procedures, Non-operative.

(e). Return to work with appropriate restrictions should be considered early in the course of treatment. Refer to Return to Work.

(f). Other therapies in Therapeutic Procedures, Non-operative may be employed in individual cases.

vi. Surgical Indications/Considerations:

(a). Carefully consider the patients' normal daily activity level before initiation of surgical intervention. Isolated Grade 1 instability does not require surgical intervention. Grades 2 or 3 may have surgical intervention if there remains demonstrable instability which interferes with athletic or work pursuits of the patient. In a second degree strain there is significant posterior motion of the tibia on the femur in active testing. A third degree strain demonstrates rotary instability due to medial or lateral structural damage. Surgery is most commonly done when the PCL rupture is accompanied by multi-ligament injury. Not recommended as an isolated procedure in patients over 50 with Grade 3 or 4 osteoarthritis.

(b). Prior to surgical intervention, the patient and treating physician should identify functional operative goals and the likelihood of achieving improved ability to perform activities of daily living or work activities and the patient should agree to comply with the pre- and post-operative treatment plan including home exercise. The provider should be especially careful to make sure the patient understands the amount of post-operative therapy required and the length of partial- and full-disability expected post-operatively.

(c). Smoking may affect soft tissue healing through tissue hypoxia. Patients should be strongly encouraged to stop smoking and be provided with appropriate counseling by the physician.

vi. Operative Procedures: Autograft or allograft reconstruction.

vii. Post-Operative Treatment

(a). An individualized rehabilitation program based upon communication between the surgeon and the therapist and using therapies as outlined in Section F. Therapeutic Procedures, Non-operative.

(b). Treatment may include active therapy with or without passive therapy, bracing.

(c). Return to work and restrictions after surgery may be made by an attending physician experienced in

occupational medicine in consultation with the surgeon or by the surgeon.

k. Tendonopathy

i. Description/Definition. Inflammation of the lining of the tendon sheath or of the enclosed tendon. Usually occurs at the point of insertion into bone or a point of muscular origin. Can be associated with bursitis, calcium deposits, or systemic connective diseases.

ii. Occupational Relationship: Extreme or repetitive trauma, strain, or excessive unaccustomed exercise or work.

iii. Specific Physical Exam Findings: Involved tendons may be visibly swollen with possible fluid accumulation and inflammation; popping or crepitus; and decreased ROM.

iv. Diagnostic Testing Procedures. Lab work may be done to rule out inflammatory disease. Other tests are rarely indicated.

v. Non-Operative Treatment Procedures

(a). Initial Treatment: Ice, protected weight-bearing and/or restricted activity, possible taping and/or bracing.

(b). Medications such as analgesics and anti-inflammatories may be helpful. Refer to medication discussions in Medications and Medical Management.

(c). Patient education should include instruction in self-management techniques, ergonomics, body mechanics, home exercise, joint protection, and weight management.

(d). Benefits may be achieved through therapeutic rehabilitation and rehabilitation interventions. They should include range-of-motion (ROM), active therapies, including a home exercise program. Active therapies include, proprioception training, restoring normal joint mechanics, and clearing dysfunctions from distal and proximal structures. Passive as well as active therapies may be used for control of pain and swelling. Therapy should progress to strengthening and an independent home exercise program targeted to further improve ROM, strength, and normal joint mechanics influenced by structures distal and proximal to the knee. Refer to Therapeutic Procedures, Non-operative.

(i). Passive modalities are most effective as adjunctive treatments to improve the results of active treatment. They may be used as found as adjunctive in Therapeutic Procedures, Non-operative.

(e). For isolated patellar tendonopathy, patellar tendon strapping or taping may be appropriate.

(f). Return to work with appropriate restrictions should be considered early in the course of treatment. Refer to Return to Work.

(g). Other therapies in Therapeutic Procedures, Non-operative may be employed in individual cases.

(h). Therapeutic Injections: Steroid injections may decrease inflammation and allow the therapist to progress with functional exercise and ROM. Steroid injections under significant pressure should be avoided as the needle may be penetrating the tendon and injection into the tendon can cause possible tendon breakdown, tendon degeneration, or rupture. Injections should be minimized for patients less than 30 years of age.

(i). Time to Produce Effect: One injection.

(ii). Maximum Duration: Three injections in one year spaced at least four to eight weeks apart.

(iii). Steroid injections should be used cautiously in diabetic patients. Diabetic patients should be reminded to check their blood glucose levels at least daily for two weeks after injections.

vi. Surgical Indications/Considerations:

(a). Suspected avulsion fracture, or severe functional impairment unresponsive to a minimum of four months of active patient participation in non-operative treatment.

(b). Prior to surgical intervention, the patient and treating physician should identify functional operative goals and the likelihood of achieving improved ability to perform activities of daily living or work activities and the patient should agree to comply with the pre- and post-operative treatment plan including home exercise. The provider should be especially careful to make sure the patient understands the amount of post-operative therapy required and the length of partial- and full-disability expected post-operatively.

(c). Smoking may affect soft tissue healing through tissue hypoxia. Patients should be strongly encouraged to stop smoking and be provided with appropriate counseling by the physician.

vii. Operative Procedures: Tendon repair. Rarely indicated and only after extensive conservative therapy.

viii. Post-Operative Treatment

(a). An individualized rehabilitation program based upon communication between the surgeon and the therapist and using therapies as outlined in Therapeutic Procedures, Non-Operative.

(b). Return to work and restrictions after surgery may be made by an attending physician experienced in occupational medicine in consultation with the surgeon or by the surgeon.

### 3. Hip and Leg

a. Acetabular Fracture

i. Description/Definition: Subgroup of pelvic fractures with involvement of the hip articulation.

ii. Occupational Relationship: Usually from a traumatic injury such as a fall or crush.

iii. Specific Physical Exam Findings: Displaced fractures may have short and/or abnormally rotated lower extremity.

iv. Diagnostic Testing Procedures: Radiographs, CT scanning.

v. Non-Operative Treatment Procedures

(a). Initial Treatment: Although surgery is frequently required, protected weight-bearing may be considered for un-displaced fractures or minimally displaced fractures that do not involve the weight-bearing surface of the acetabular dome.

(b). Medications such as analgesics and anti-inflammatories may be helpful. Refer to medication discussions in Medications and Medical Management.

(c). Patient education should include instruction in self-management techniques, ergonomics, body mechanics, home exercise, joint protection, and weight management.

(d). Refer to comments on osteoporosis in Ankle Sprain/Fracture.

(e). Smoking may affect fracture healing. Patients should be strongly encouraged to stop smoking and be provided with appropriate counseling by the physician.

(f). Benefits may be achieved through therapeutic rehabilitation and rehabilitation interventions, after bony union has been achieved. They should include bracing then range-of-motion (ROM), active therapies, and a home exercise program. Active therapies include ambulation with appropriate assistive device, proprioception training, restoring normal joint mechanics, and clearing dysfunctions from adjacent structures. Passive as well as active therapies may be used for control of pain and swelling. Therapy should progress to strengthening and an independent home exercise program targeted to further improve ROM, strength, and normal joint mechanics influenced by proximal and distal structures. Therapy should include training on the use of adaptive equipment and home and work site evaluations when appropriate. Bracing may be appropriate. Refer to Therapeutic Procedures, Non-Operative.

(i). Passive modalities are most effective as adjunctive treatments to improve the results of active treatment. They may be used as found as adjunctive in Therapeutic Procedures, Non-operative.

(g). Return to work with appropriate restrictions should be considered early in the course of treatment. Refer to Return to Work.

(h). Other therapies in Therapeutic Procedures, Non-operative may be employed in individual cases.

vi. Surgical Indications/Considerations. Displaced or unstable fracture.

(a). Because smokers have a higher risk of non-union and post-operative costs, it is recommended that insurers cover a smoking cessation program peri-operatively.

Physicians may monitor smoking cessation with laboratory tests such as cotinine levels for long-term cessation.

vii. Operative Procedures: Usually open reduction and internal fixation or total hip replacement.

viii. Post-Operative Treatment

(a). An individualized rehabilitation program based upon communication between the surgeon and the therapist, and using therapies as outlined in Therapeutic Procedures, Non-operative. In all cases, communication between the physician and therapist is important to the timing of weight-bearing, and exercise progressions.

(b). Treatment usually includes active therapy with or without passive therapy for early range of motion and weight-bearing then progression to, strengthening, flexibility, neuromuscular training, and gait training with appropriate assistive devices.

(c). Return to work and restrictions after surgery may be made by an attending physician experienced in occupational medicine in consultation with the surgeon or by the surgeon.

b. Aggravated Osteoarthritis

i. Description/Definition: hip pain with radiographic evidence of joint space narrowing or femoral acetabular osteophytes, and sedimentation rate less than 20mm/hr with symptoms. Patients usually have gradual onset of pain increasing with use and relieved with rest, progressing to morning stiffness and then to night pain.

ii. Occupational Relationship: The provider must establish the occupational relationship by establishing a change in the patient's baseline condition and a relationship to work activities including but not limited to repetitive heavy lifting or specific injury to the hip.

(a). Other causative factors to consider: Prior significant injury to the hip may predispose the joint to osteoarthritis. In order to entertain previous trauma as a cause, the patient should have a medically documented injury with radiographs or MRI showing the level of anatomic change. The prior injury should have been at least two years from the presentation for the new complaints and there should be a significant increase of pathology on the affected side in comparison to the original imaging or operative reports and/or the opposite un-injured side or extremity.

iii. Specific Physical Exam Findings: Bilateral exam including knees and low back is necessary to rule out other diagnoses. Pain with the hip in external and/or internal hip rotation with the knee in extension is the strongest indicator.

iv. Diagnostic Testing Procedures: standing pelvic radiographs demonstrating joint space narrowing to 2 mm or less, osteophytes or sclerosis at the joint. MRI may be ordered to rule out other more serious disease.

v. Non-Operative Treatment Procedures

(a). Medications such as analgesics and anti-inflammatories may be helpful. Refer to medication discussions in Medications and Medical Management.

(b). Patient education should include instruction in self-management techniques, ergonomics, body mechanics, home exercise, joint protection, and weight management. Patient education may also include videos, telephone, follow-up, and pamphlets.

(c). Benefits may be achieved through therapeutic rehabilitation and rehabilitation interventions. They should include range-of-motion (ROM), active therapies and a home exercise program. Active therapies include gait training with appropriate assistive devices, proprioception training restoring normal joint mechanics, and clearing dysfunctions from adjacent structures. Passive as well as active therapies may be used for control of pain and swelling. Therapy should progress to strengthening and an independent home exercise program targeted to further improve ROM, strength, and normal joint mechanics influenced by proximal and distal structures. Therapy should include training on the use of adaptive equipment and home and work site evaluations when appropriate Refer to Therapeutic Procedures, Non-operative. There is good evidence that a supervised therapeutic exercise program with an element of strengthening is an effective treatment for hip osteoarthritis.

(i). Passive modalities are most effective as adjunctive treatments to improve the results of active treatment. They may be used as found as adjunctive in Therapeutic Procedures, Non-operative. There is some evidence that manual therapy, including stretching and traction manipulation by a trained provider, produces functional improvement in hip osteoarthritis and may be a suitable treatment option.

[a]. Aquatic therapy may be used as a type of active intervention to improve muscle strength and range of motion when land-based therapy is not well-tolerated.

[b]. The use of insoles, adaptive equipment, cane, may be beneficial.

[c]. There is some evidence that acupuncture may produce improvement in hip pain and function, making it a suitable treatment option for patients. Refer to Therapeutic Procedures, Non-operative.

[d]. Steroid Injections - Steroid injections may decrease inflammation and allow the therapist to progress with functional exercise and ROM.

[i]. Time to Produce Effect: One injection.

[ii]. Maximum Duration: Three injections in one year spaced at least four to eight weeks apart.

[iii]. Steroid injections should be used cautiously in diabetic patients. Diabetic patients should be reminded to check their blood glucose levels at least daily for two weeks after injections.

[e]. Return to work with appropriate restrictions should be considered early in the course of treatment. Refer to Return to Work.

[f]. Other therapies in Therapeutic Procedures, Non-operative may be employed in individual cases.

vi. Surgical Indications/Considerations

(a). When pain interferes with ADLs and the patient meets the following: low surgical risk, adequate bone quality, and failure of previous non-surgical interventions including weight control, therapy with active patient participation, and medication. Refer to Therapeutic Procedures-operative, Hip Arthroplasty, for indications specific to the procedure.

(b). Prior to surgical intervention, the patient and treating physician should identify functional operative goals and the likelihood of achieving improved ability to perform activities of daily living or work activities and the patient should agree to comply with the pre- and post-operative treatment plan including home exercise. The provider should be especially careful to make sure the patient understands the amount of post-operative therapy required and the length of partial- and full-disability expected post-operatively.

(c). In cases where surgery is contraindicated due to obesity, it may be appropriate to recommend a weight loss program if the patient is unsuccessful losing weight on their own. Coverage for weight loss would continue only for motivated patients who have demonstrated continual progress with weight loss.

(d). Because smokers have a higher risk of non-union and post-operative costs, it is recommended that carriers cover a smoking cessation program peri-operatively. Physicians may monitor smoking cessation with laboratory tests such as cotinine levels for long-term cessation.

vii. Operative Procedures: Prosthetic replacement (traditional or minimally invasive), or resurfacing.

viii. Post-Operative Treatment

(a). In all cases, communication between the physician and therapist is important to the timing of weight-bearing and exercise progressions.

(b). For prosthetic replacement, refer to Hip Arthroplasty.

(c). Return to work and restrictions after surgery may be made by an attending physician experienced in occupational medicine in consultation with the surgeon or by the surgeon.

c. Femoral Osteonecrosis (Avascular Necrosis (AVN) of the Femoral Head)

i. Description/Definition. Death of the bone tissue of the femoral head following loss of blood supply to the area. Destruction of the articular surfaces of the hip joint may lead to arthritis.

ii. Occupational Relationship. Trauma resulting in displaced subcapital fracture of the hip or hip dislocation

may cause AVN. Previous surgical procedures and systemic steroids may lead to AVN. In the general population risk factors include, but are not limited to alcohol abuse, smoking, Caisson disease (also known as the bends), sickle cell anemia, autoimmune disease, and hypercoagulable states. Often, the cause cannot be identified. Involvement of the opposite hip may occur in more than half of cases not caused by trauma.

iii. Specific Physical Exam Findings. Hip or groin pain made worse by motion or weight-bearing and alleviated by rest is the classical presentation. Symptoms may begin gradually, often months after the vascular compromise of blood flow. A limp may result from the limited toleration of weight-bearing.

iv. Diagnostic Testing Procedures. X-ray abnormalities include sclerotic changes, cystic lesions, joint space narrowing, and degeneration of the acetabulum. The x-ray may be normal in the first several months of the disease process. AVN should be suspected when hip pain occurs and risk factors are present. X-rays should be done first, but may be followed by an MRI. When AVN is not due to trauma, both hips should be imaged.

v. Non-operative Treatment Procedures

(a). Initial Treatment: protected weight-bearing and bracing followed by active therapy with or without passive therapy. Conservative approaches may suffice when the lesion is small, but larger lesions are expected to require surgical intervention when symptoms are disabling.

(b). Medications such as analgesics and anti-inflammatories may be helpful. Refer to medication discussions in Medications and Medical Management.

(c). Patient education should include instruction in self-management techniques, ergonomics, body mechanics, home exercise, joint protection, and weight management. Weight-bearing restrictions may be appropriate.

(d). Smoking may affect bone healing. Patients should be strongly encouraged to stop smoking and be provided with appropriate counseling by the physician.

(e). Return to work with appropriate restrictions should be considered early in the course of treatment. Refer to Return to Work.

(f). Other therapies in Therapeutic Procedures, Non-operative, may be employed in individual cases.

vi. Surgical Indications/Considerations: Core decompression may appropriate for some patients with early disease (Stages 1 and 2A) who have functionally disabling symptoms. Femoral head osteotomies or resurfacing hemiarthroplasties may also be appropriate for younger patients when disease is limited to the femoral head. Those 50 or older and patients with total joint collapse or severely limiting disease will usually require an implant arthroplasty.

(a). Prior to surgical intervention, the patient and treating physician should identify functional operative goals

and the likelihood of achieving improved ability to perform activities of daily living or work activities and the patient should agree to comply with the pre- and post-operative treatment plan including home exercise. The provider should be especially careful to make sure the patient understands the amount of post-operative therapy required and the length of partial- and full-disability expected post-operatively.

(b). Because smokers have a higher risk of non-union and post-operative costs, it is recommended that insurers cover a smoking cessation program peri-operatively. Physicians may monitor smoking cessation with laboratory tests such as cotinine levels for long-term cessation.

vii. Operative Procedures. Osteotomy, core decompression with or without bone graft, prosthetic replacement. Refer to Therapeutic Procedures-operative for details.

viii. Post-Operative Treatment

(a). Anticoagulant therapy to prevent deep venous thrombosis for most procedures. Refer to Therapeutic Procedures, Non-operative.

(b). Treatment usually includes active therapy with or without passive therapy. Refer to Therapeutic Procedures-Operative and specific procedures for further details.

(c). An individualized rehabilitation program based upon communication between the surgeon and the therapist using the treatments found in Therapeutic Procedures, Non-operative.

(d). Treatment should include gait training with appropriate assistive devices.

(e). Therapy should include training on the use of adaptive equipment and home and work site evaluation when appropriate.

(f). Return to work and restrictions after surgery may be made by an attending physician experienced in occupational medicine in consultation with the surgeon or by the surgeon

d. Femur Fracture

i. Description/Definition. Fracture of the femur distal to the lesser trochanter.

ii. Occupational Relationship. Usually from a traumatic injury such as a fall or crush.

iii. Specific Physical Exam Findings: May have a short, abnormally rotated extremity. Effusion if the knee joint is involved.

iv. Diagnostic Testing Procedures: Radiographs. Occasionally CT scan or MRI particularly if the knee joint is involved.

v. Non-operative Treatment Procedures

(a). Initial Treatment. Although surgery is usually required, non-operative procedures may be

considered in stable, non-displaced fractures and will require protected weight-bearing.

(b). Medications such as analgesics and anti-inflammatories may be helpful. Refer to medication discussions in Medications and Medical Management.

(c). Back pain may occur after femur fracture and should be addressed and treated as necessary.

(d). Patient education should include instruction in self-management techniques, ergonomics, body mechanics, home exercise, joint protection, weight management. Weight-bearing restrictions may be appropriate.

(e). Refer to comments related to osteoporosis in Therapeutic Procedures, Non-operative, Osteoporosis Management.

(f). Smoking may affect fracture healing. Patients should be strongly encouraged to stop smoking and be provided with appropriate counseling by the physician.

(g). Orthotics such as heel lifts and custom shoe build-ups may be required when leg-length discrepancy persists.

(h). Return to work with appropriate restrictions should be considered early in the course of treatment. Refer to Return to Work.

(i). Other therapies in Therapeutic Procedures, Non-operative may be employed in individual cases.

vi. Surgical Indications/Considerations. Femoral neck fracture or supracondylar femur fracture with joint incongruity.

(a). Because smokers have a higher risk of non-union and post-operative costs, it is recommended that insurers cover a smoking cessation program peri-operatively. Physicians may monitor smoking cessation with laboratory tests such as cotinine levels for long-term cessation.

vii. Operative Procedures: Rod placement or open internal fixation.

viii. Post-Operative Treatment

(a). An individualized rehabilitation program based upon communication between the surgeon and the therapist, using therapies as outlined in Therapeutic Procedures, Non-operative. In all cases, communication between the physician and the therapist is important to the timing of weight-bearing and exercise progression.

(b). Treatment usually includes active therapy with or without passive therapy for protected weight-bearing, early range of motion if joint involvement.

(c). Refer to bone-growth stimulators in Therapeutic Procedures, Non-operative.

(d). Return to work and restrictions after surgery may be made by an attending physician experienced in occupational medicine in consultation with the surgeon or by the surgeon.

## (e). Hamstring Tendon Rupture

(i). Description/Definition. Most commonly, a disruption of the muscular portion of the hamstring. Extent of the tear is variable. Occasionally a proximal tear or avulsion. Rarely a distal injury.

(ii). Occupational Relationship: Excessive tension on the hamstring either from an injury or from a rapid, forceful contraction of the muscle.

(iii). Specific Physical Exam Findings: Local tenderness, swelling, ecchymosis.

(iv). Diagnostic Testing Procedures: Occasionally radiographs or MRI for proximal tears/possible avulsion.

## (v). Non-operative Treatment Procedures

[a]. Initial Treatment: Protected weight-bearing and ice.

[b]. Medications such as analgesics and anti-inflammatories may be helpful. Refer to medication discussions in Medications and Medical Management.

[c]. Patient education should include instruction in self-management techniques, ergonomics, body mechanics, home exercise, and weight management.

[d]. Benefits may be achieved through therapeutic rehabilitation and rehabilitation interventions. They may include range-of-motion (ROM), active therapies, and a home exercise program. Active therapies include proprioception training, restoring normal joint mechanics, and clearing dysfunctions from adjacent structures. Passive as well as active therapies may be used for control of pain and swelling. Therapy should progress to strengthening and an independent home exercise program targeted to further improve ROM, strength, and normal joint mechanics influenced by proximal and distal structures. Bracing may be appropriate. Refer to Therapeutic Procedures, Non-operative.

[i]. Passive modalities are most effective as adjunctive treatments to improve the results of active treatment. They may be used as found as adjunctive in Therapeutic Procedures, Non-operative.

[e]. Return to work with appropriate restrictions should be considered early in the course of treatment. Refer to Return to Work.

[f]. Other therapies in Therapeutic Procedures, Non-operative may be employed in individual cases.

## vi. Surgical Indications/Considerations

(a). Surgery is indicated for proximal or distal injuries only when significant functional impairment is expected without repair. If surgery is indicated, it is preferably performed within three months.

(b). Prior to surgical intervention, the patient and treating physician should identify functional operative goals and the likelihood of achieving improved ability to perform

activities of daily living or work activities and the patient should agree to comply with the pre- and post-operative treatment plan including home exercise. The provider should be especially careful to make sure the patient understands the amount of post-operative therapy required and the length of partial- and full-disability expected post-operatively.

(c). Smoking may affect soft tissue healing through tissue hypoxia. Patients should be strongly encouraged to stop smoking and be provided with appropriate counseling by the physician.

vii. Operative Procedures: Re-attachment of proximal avulsions and repair of distal tendon disruption.

## viii. Post-Operative Treatment

(a). An individualized rehabilitation program based upon communication between the surgeon and the therapist using therapies as outlined in Therapeutic Procedures, Non-operative. In all cases, communication between the physician and therapist is important to the timing of weight-bearing and exercise progressions.

(b). Treatment may include protected weight-bearing and active therapy with or without passive therapy. Splinting in a functional brace may reduce time off work.

(c). Return to work and restrictions after surgery may be made by an attending physician experienced in occupational medicine in consultation with the surgeon or by the surgeon.

## f. Hip Dislocation

i. Description/Definition. Disengagement of the femoral head from the acetabulum.

ii. Occupational Relationship. Usually from a traumatic injury such as a fall or crush.

iii. Specific Physical Exam Findings: Most commonly a short, internally rotated, adducted lower extremity with a posterior dislocation and a short externally rotated extremity with an anterior dislocation.

iv. Diagnostic Testing Procedures: Radiographs, CT scanning.

## v. Non-operative Treatment Procedures

(a). Initial Treatment: Urgent closed reduction with sedation or general anesthesia.

(b). Medications such as analgesics and anti-inflammatories may be helpful. Refer to medication discussions in Medications and Medical Management.

(c). Patient education should include instruction in self-management techniques, ergonomics, body mechanics, home exercise, joint protection, and weight management.

(d). Benefits may be achieved through therapeutic rehabilitation and rehabilitation interventions. They should include bracing then range-of-motion (ROM), active therapies, and a home exercise program. Active therapies include proprioception training, gait training with

appropriate assistive devices, restoring normal joint mechanics, and clearing dysfunctions from adjacent structures. Passive as well as active therapies may be used for control of pain and swelling. Therapy should progress to strengthening and an independent home exercise program targeted to further improve ROM, strength, and normal joint mechanics influenced by proximal and distal structures. Therapy should include training on the use of adaptive equipment and home and work site evaluations when appropriate. Bracing may be appropriate. Refer to Therapeutic Procedures, Non-operative.

(i). Passive modalities are most effective as adjunctive treatments to improve the results of active treatment. They may be used as found as adjunctive in Therapeutic Procedures, Non-operative.

(e). Return to work with appropriate restrictions should be considered early in the course of treatment. Refer to Return to Work.

(f). Other therapies in Therapeutic Procedures, Non-operative may be employed in individual cases.

vi. Surgical Indications/Considerations: Failure of closed reduction. Associated fracture of the acetabulum or femoral head, loose fragments in joint or open fracture.

(a). Because smokers have a higher risk of non-union and post-operative costs, when a fracture is involved it is recommended that insurers cover a smoking cessation program peri-operatively. Physicians may monitor smoking cessation with laboratory tests such as cotinine levels for long-term cessation.

vii. Operative Procedures. Open reduction of the femoral head or acetabulum and possible internal fixation.

viii. Post-Operative Treatment Procedures

(a). An individualized rehabilitation program based upon communication between the surgeon and the therapist using therapies as outlined in Therapeutic Procedures, Non-operative. In all cases, communication between the physician and therapist is important to the timing of weight-bearing and exercise progressions.

(b). Treatment should include gait training with appropriate assistive devices.

(c). Treatment may include protected weight-bearing and active therapy with or without passive therapy for early range of motion.

(d). Return to work and restrictions after surgery may be made by an attending physician experienced in occupational medicine in consultation with the surgeon or by the surgeon.

g. Hip Fracture

i. Description/Definition. Fractures of the neck and peri-trochanteric regions of the proximal femur.

ii. Occupational Relationship: Usually from a traumatic injury such as a fall or crush. Patients with intracapsular femoral fractures have a risk of developing

avascular necrosis of the femoral head requiring treatment months to years after the initial injury.

iii. Specific Physical Exam Findings. Often a short and externally rotated lower extremity.

iv. Diagnostic Testing Procedures: Radiographs. Occasional use of CT scan or MRI.

v. Non-operative Treatment Procedures

(a). Initial Treatment: protected weight-bearing and bracing followed by active therapy with or without passive therapy. Although surgery is usually required, non-operative procedures may be considered in stable, non-displaced fractures.

(b). Medications such as analgesics and anti-inflammatories may be helpful. Refer to medication discussions in Medications and Medical Management.

(c). Back pain may occur after hip fracture and should be addressed and treated as necessary.

(d). Patient education should include instruction in self-management techniques, ergonomics, body mechanics, home exercise, joint protection, and weight management. Weight-bearing restrictions may be appropriate.

(e). Refer to comments on osteoporosis in Ankle Sprain/Fracture.

(f). Smoking may affect fracture healing. Patients should be strongly encouraged to stop smoking and be provided with appropriate counseling by the physician.

(g). Return to work with appropriate restrictions should be considered early in the course of treatment. Refer to Return to Work.

(h). Other therapies in Therapeutic Procedures, Non-operative, may be employed in individual cases.

vi. Surgical Indications/Considerations. Surgery is indicated for unstable peritrochanteric fractures and femoral neck fractures.

(a). Because smokers have a higher risk of non-union and post-operative costs, it is recommended that insurers cover a smoking cessation program peri-operatively. Physicians may monitor smoking cessation with laboratory tests such as cotinine levels for long-term cessation.

vii. Operative Procedures: Prosthetic replacement for displaced femoral neck fractures. Reduction and internal fixation for peritrochanteric fractures, and un-displaced, or minimally-displaced neck fractures.

viii. Post-Operative Treatment

(a). Anti coagulant therapy to prevent deep venous thrombosis. Refer to Therapeutic Procedures, Non-operative.

(b). Treatment usually includes active therapy with or without passive therapy.



(c). An individualized rehabilitation program based upon communication between the surgeon and the therapist using the treatments found in Therapeutic Procedures, Non-operative.

(d). Treatment should include gait training with appropriate assistive devices.

(e). Therapy should include training on the use of adaptive equipment and home and work site evaluation when appropriate.

(f). Return to work and restrictions after surgery may be made by an attending physician experienced in occupational medicine in consultation with the surgeon or by the surgeon.

#### h. Impingement/Labral Tears

i. Description/Definition: Two types of impingement are described pincer; resulting from over coverage of the acetabulum and/or cam; resulting from aspherical portion of the head and neck junction. Persistence of these abnormalities can cause early arthritis or labral tears. Labral tears can also be isolated; however, they are frequently accompanied by bony abnormalities. Patients usually complain of catching or painful clicking which should be distinguished from a snapping iliopsoas tibial tendon. A pinch while sitting may be reported and hip or groin pain.

ii. Occupational Relationship: Impingement abnormalities are usually congenital; however, they may be aggravated by repetitive rotational force or trauma. Labral tears may accompany impingement or result from high energy trauma.

iii. Specific Physical Exam Findings. Positive labral tests.

iv. Diagnostic Testing Procedures. Cross table laterals, standing AP pelvis and frog leg lateral x-rays. MRI may reveal abnormality; however, false positives and false negatives are also possible. MRI arthrogram with gadolinium should be performed to diagnose labral tears, not a pelvic MRI. Intra-articular injection should help rule out extra-articular pain generators. To confirm the diagnosis, the patient should demonstrate changes on a pain scale accompanied by recorded functional improvement post-injection. This is important, as labral tears do not always cause pain and over-diagnosis is possible using imaging alone.

#### v. Non-Operative Treatment Procedures

(a). Medications such as analgesics and anti-inflammatories may be helpful. Refer to medication discussions in Medications and Medical Management.

(b). Patient education should include instruction in self-management techniques, ergonomics, body mechanics, reducing hip adduction and internal rotation home exercise, joint protection, and weight management.

(c). Benefits may be achieved through therapeutic rehabilitation and rehabilitation interventions.

They should include range-of-motion (ROM), active therapies and a home exercise program. Active therapies include proprioception training, restoring normal joint mechanics, and clearing dysfunctions from adjacent structures. Passive as well as active therapies may be used for control of pain and swelling. Therapy should progress to strengthening and an independent home exercise program targeted to further improve ROM, strength, and normal joint mechanics influenced by proximal and distal structures. Refer to Therapeutic Procedures, Non-operative.

(i). Passive modalities are most effective as adjunctive treatments to improve the results of active treatment. They may be used as found as adjunctive in Therapeutic Procedures, Non-operative.

(d). Steroid Injections. Steroid injections may decrease inflammation and allow the therapist to progress with functional exercise and ROM.

(i). Time to Produce Effect: One injection.

(ii). Maximum Duration: Three injections in one year spaced at least four to eight weeks apart.

(iii). Steroid injections should be used cautiously in diabetic patients. Diabetic patients should be reminded to check their blood glucose levels at least daily for two weeks after injections.

(e). Return to work with appropriate restrictions should be considered early in the course of treatment. Refer to Return to Work.

(f). Other therapies in Therapeutic Procedures, Non-operative may be employed in individual cases.

#### vi. Surgical Indications/Considerations:

(a). Surgery is indicated when functional limitations persist after eight weeks of active patient participation in treatment, there are clinical signs and symptoms suggestive of the diagnosis and other diagnoses have been ruled out.

(b). Prior to surgical intervention, the patient and treating physician should identify functional operative goals and the likelihood of achieving improved ability to perform activities of daily living or work activities and the patient should agree to comply with the pre- and post-operative treatment plan including home exercise. The provider should be especially careful to make sure the patient understands the amount of post-operative therapy required and the length of partial- and full-disability expected post-operatively.

(c). In cases where surgery is contraindicated due to obesity, it may be appropriate to recommend a weight loss program if the patient is unsuccessful losing weight on their own. Coverage for weight loss would continue only for motivated patients who have demonstrated continual progress with weight loss.

(d). Smoking may affect soft tissue healing through tissue hypoxia. Patients should be strongly encouraged to stop smoking and be provided with appropriate counseling by the physician.

vii. Operative Procedures: Debridement or repair of labrum and removal of excessive bone.

viii. Post-Operative Treatment

(a). When bone is removed and/or the labrum is repaired, weight-bearing restrictions usually apply.

(b). An individualized rehabilitation program based upon communication between the surgeon and the therapist that should include gait training with appropriate assistive devices. Refer to Therapeutic Procedures Non-operative.

(c). Return to work and restrictions after surgery may be made by an attending physician experienced in occupational medicine in consultation with the surgeon or by the surgeon.

i. Pelvic Fracture

i. Description/Definition. Fracture of one or more components of the pelvic ring (sacrum and iliac wings).

ii. Occupational Relationship. Usually from a traumatic injury such as a fall or crush.

iii. Specific Physical Exam Findings. Displaced fractures may cause pelvic deformity and shortening, or rotation of the lower extremities.

iv. Diagnostic Testing Procedures: Radiographs, CT scanning. Occasionally MRI, angiogram, urethrogram, emergent sonogram.

v. Non-operative Treatment Procedures

(a). Initial Treatment: Protected weight-bearing. Although surgery is usually required, non-operative procedures may be considered in a stable, non-displaced fracture.

(b). Medications such as analgesics and anti-inflammatories may be helpful. Refer to medication discussions in Medications and Medical Management.

(c). Patient education should include instruction in self-management techniques, ergonomics, body mechanics, home exercise, joint protection, and weight management.

(d). Refer to comments related to osteoporosis in Therapeutic Procedures, Non-operative, Osteoporosis Management.

(e). Smoking may affect fracture healing. Patients should be strongly encouraged to stop smoking and be provided with appropriate counseling by the physician.

(f). Benefits may be achieved through therapeutic rehabilitation and rehabilitation interventions, after bony union has been achieved. They should include bracing then range-of-motion (ROM), active therapies, and a home exercise program. Active therapies include, proprioception training, gait training with appropriate assistive devices, restoring normal joint mechanics, and clearing dysfunctions from adjacent structures. Passive as well as active therapies may be used for control of pain and

swelling. Therapy should progress to strengthening and an independent home exercise program targeted to further improve ROM, strength, and normal joint mechanics influenced by proximal and distal structures. Therapy should include training on the use of adaptive equipment and home and work site evaluations when appropriate. Refer to Therapeutic Procedures, Non-operative.

(i). Passive modalities are most effective as adjunctive treatments to improve the results of active treatment. They may be used as found as adjunctive in Therapeutic Procedures, Non-operative.

(g). Return to work with appropriate restrictions should be considered early in the course of treatment. Refer to Return to Work.

(h). Other therapies in Therapeutic Procedures, Non-operative may be employed in individual cases.

vi. Surgical Indications/Considerations. Unstable fracture pattern, or open fracture.

(a). Because smokers have a higher risk of non-union and post-operative costs, it is recommended that insurers cover a smoking cessation program peri-operatively. Physicians may monitor smoking cessation with laboratory tests such as cotinine levels for long-term cessation.

vii. Operative Procedures. External or internal fixation dictated by fracture pattern.

viii. Post-Operative Treatment

(a). An individualized rehabilitation program based upon communication between the surgeon and the therapist using therapies as outlined in Therapeutic Procedures, Non-operative. In all cases, communication between the physician and therapist is important to the timing of weight-bearing and exercise progressions.

(b). Treatment usually includes active therapy with or without passive therapy for gait, pelvic stability, strengthening, and restoration of joint and extremity function. Treatment should include gait training with appropriate assistive devices.

(c). Graduated weight-bearing according to fracture healing.

(d). Return to work and restrictions after surgery may be made by an attending physician experienced in occupational medicine in consultation with the surgeon or by the surgeon.

j. Tendonopathy: Refer to Tendonopathy for general recommendations.

k. Tibial Fracture

i. Description/Definition. Fracture of the tibia proximal to the malleoli.

(a). Open tibial fractures are graded in severity according to the Gustilo-Anderson Classification:

(i). Type I: Less than 1 cm (puncture wounds).

- (ii). Type II: 1 to 10 cm.
- (iii). Type III-A: Greater than 10 cm, sufficient soft tissue preserved to cover the wound (includes gunshot wounds and any injury in a contaminated environment).
- (iv). Type III-B: Greater than 10 cm, requiring a soft tissue coverage procedure.
- (v). Type III-C: With vascular injury requiring repair.
  - ii. Occupational Relationship. Usually from a traumatic injury such as a fall or crush.
  - iii. Specific Physical Exam Findings. May have a short, abnormally rotated extremity. Effusion if the knee joint involved.
  - iv. Diagnostic Testing Procedures: Radiographs. CT scanning or MRI.
  - v. Non-operative Treatment Procedures:
    - (a). Initial Treatment—protected weight-bearing; functional bracing. There is some evidence for use of pneumatic braces with stress fractures.
    - (b). Medications such as analgesics and anti-inflammatories may be helpful. Refer to medication discussions in Medications and Medical Management.
    - (c). Patient education should include instruction in self-management techniques, ergonomics, body mechanics, home exercise, joint protection, and weight management.
    - (d). Refer to comments related to osteoporosis in Therapeutic Procedures, Non-operative, Osteoporosis Management.
    - (e). Smoking may affect fracture healing. Patients should be strongly encouraged to stop smoking and be provided with appropriate counseling by the physician.
    - (f). Benefits may be achieved through therapeutic rehabilitation and rehabilitation interventions, after boney union has been achieved. They should include bracing then range-of-motion (ROM), active therapies including proprioception training, restoring normal joint mechanics, and clearing dysfunctions from adjacent structures, and a home exercise program. Passive as well as active therapies may be used for control of pain and swelling. Therapy should progress to strengthening and an independent home exercise program targeted to further improve ROM, strength, restoring normal joint mechanics, influenced by proximal and distal structures. Therapy should include training on the use of adaptive equipment and home and work site evaluations when appropriate. Bracing may be appropriate. Refer to Therapeutic Procedures, Non-operative.
      - (i). Passive modalities are most effective as adjunctive treatments to improve the results of active treatment. They may be used as adjunctive in Therapeutic Procedures, Non-operative.

(g). Orthotics such as heel lifts and custom shoe build-ups may be required when leg-length discrepancy persists.

(h). Return to work with appropriate restrictions should be considered early in the course of treatment. Refer to Return to Work.

(i). Other therapies in Therapeutic Procedures, Non-operative may be employed in individual cases.

vi. Surgical Indications/Considerations. Unstable fracture pattern, displaced fracture (especially if the knee joint is involved), open fracture, and non-union.

(a). Because smokers have a higher risk of non-union and post-operative costs, it is recommended that insurers cover a smoking cessation program peri-operatively. Physicians may monitor smoking cessation with laboratory tests such as cotinine levels for long-term cessation.

vii. Operative Procedures. Often closed rodding for shaft fractures. Open reduction and internal fixation more common for fractures involving the knee joint or pilon fractures of the distal tibia.

(a). Human bone morphogenetic protein (RhBMP): this material is used for surgical repair of open tibial fractures. Refer to Therapeutic Procedures, Operative for further specific information.

(b). Stem cell use - stem cells have been added to allograft to increase fracture union. Their use is considered experimental and is not recommended at this time.

#### viii. Post-Operative Treatment

(a). An individualized rehabilitation program based upon communication between the surgeon and the therapist and using therapies as outlined in Therapeutic Procedures, Non-operative. In all cases, communication between the physician and therapist is important to the timing of weight-bearing and exercise progressions.

(b). Treatment may include protected weight-bearing and active therapy with or without passive therapy for early range of motion if joint involvement.

(c). Return to work and restrictions after surgery may be made by an attending physician experienced in occupational medicine in consultation with the surgeon or by the surgeon.

#### 1. Trochanteric Fracture

i. Description/Definition: Fracture of the greater trochanter of the proximal femur.

ii. Occupational Relationship. Usually from a traumatic injury such as a fall or crush.

iii. Specific Physical Exam Findings: Local tenderness over the greater trochanter. Sometimes associated swelling, ecchymosis.

iv. Diagnostic Testing Procedures. Radiographs, CT scans or MRI.

v. Non-operative Treatment Procedures:

(a). Initial Treatment: protected weight-bearing.

(b.) Medications such as analgesics and anti-inflammatories may be helpful. Refer to medication discussions in Medications and Medical Management.

(c). Patient education should include instruction in self-management techniques, ergonomics, body mechanics, home exercise, joint protection, and weight management.

(d). Refer to comments related to osteoporosis in Therapeutic Procedures, Non-operative, Osteoporosis Management.

(e). Smoking may affect fracture healing. Patients should be strongly encouraged to stop smoking and be provided with appropriate counseling by the physician.

(f). Benefits may be achieved through therapeutic rehabilitation and rehabilitation interventions, after boney union has been achieved. They should include bracing then range-of-motion (ROM), active therapies, and a home exercise program. Active therapies include proprioception training, restoring normal joint mechanics, and clearing dysfunctions from adjacent structures, and a home exercise program. Passive as well as active therapies may be used for control of pain and swelling. Therapy should progress to strengthening and an independent home exercise program targeted to further improve ROM, strength, and normal joint mechanics influenced by proximal and distal structures. Bracing may be appropriate. Refer to Therapeutic Procedures, Non-operative.

(i). Passive modalities are most effective as adjunctive treatments to improve the results of active treatment. They may be used as found as adjunctive in Therapeutic Procedures, Non-operative.

(g). Return to work with appropriate restrictions should be considered early in the course of treatment. Refer to Return to Work.

(h). Other therapies in Therapeutic Procedures, Non-operative may be employed in individual cases.

vi. Surgical Indications/Considerations. Large, displaced fragment, open fracture.

(a). Because smokers have a higher risk of non-union and post-operative costs, it is recommended that insurers cover a smoking cessation program peri-operatively. Physicians may monitor smoking cessation with laboratory tests such as cotinine levels for long-term cessation.

vii. Operative Procedures: Open reduction, internal fixation.

viii. Post-Operative Treatment

(a). An individualized rehabilitation program based upon communication between the surgeon and the therapist using therapies as outlined in Therapeutic Procedures, Non-operative. In all cases, communication

between the physician and therapist is important to the timing of weight-bearing and exercise progressions.

(b). Protected weight-bearing is usually needed. Full weight-bearing with radiographic and clinical signs of healing.

(c). Return to work and restrictions after surgery may be made by an attending physician experienced in occupational medicine in consultation with the surgeon or by the surgeon.

AUTHORITY NOTE: Promulgated in accordance with R.S. 23:1203.1.

HISTORICAL NOTE: Promulgated by the Louisiana Workforce Commission, Office of Workers Compensation Administration, LR 37:1772 (June 2011), amended LR 48:515 (March 2022).

**§2311. Therapeutic Procedures—Non-Operative**

A. Treating providers, as well as employers and insurers are highly encouraged to reference the General Guidelines Principles (Section B) prior to initiation of any therapeutic procedure. Before initiation of any therapeutic procedure, the authorized treating provider, employer and insurer must consider these important issues in the care of the injured worker.

B. First, patients undergoing therapeutic procedure(s) should be released or returned to modified, restricted duty during their rehabilitation at the earliest appropriate time. Refer to Return-to-Work in this section for detailed information.

C. Second, cessation and/or review of treatment modalities should be undertaken when no further significant subjective or objective improvement in the patient's condition is noted. If patients are not responding within the recommended duration periods, alternative treatment interventions, further diagnostic studies or consultations should be pursued.

D. Third, providers should provide and document education to the patient. No treatment plan is complete without addressing issues of individual and/or group patient education as a means of facilitating self-management of symptoms.

E. Lastly, formal psychological or psychosocial evaluation should be performed on patients not making expected progress within 6 to 12 weeks following injury and whose subjective symptoms do not correlate with objective signs and tests.

F. In cases where a patient is unable to attend an outpatient center, home therapy may be necessary. Home therapy may include active and passive therapeutic procedures as well as other modalities to assist in alleviating pain, swelling, and abnormal muscle tone. Home therapy is usually of short duration and continues until the patient is able to tolerate coming to an outpatient center.

G. The following procedures are listed in alphabetical order.

1. Acupuncture is an accepted and widely used procedure for the relief of pain and inflammation in the lower extremity. There is some scientific evidence to support its use for hip and knee osteoarthritis. The exact mode of action is only partially understood. Western medicine studies suggest that acupuncture stimulates the nervous system at the level of the brain, promotes deep relaxation, and affects the release of neurotransmitters. Acupuncture is commonly used as an alternative or in addition to traditional Western pharmaceuticals. While it is commonly used when pain medication is reduced or not tolerated, it may be used as an adjunct to physical rehabilitation and/or surgical intervention to hasten the return of functional activity. Acupuncture should be performed by licensed practitioners.

a. Acupuncture is the insertion and removal of filiform needles to stimulate acupoints (acupuncture points). Needles may be inserted, manipulated and retained for a period of time. Acupuncture can be used to reduce pain, reduce inflammation, increase blood flow, increase range-of-motion, decrease the side effect of medication-induced nausea, promote relaxation in an anxious patient, and reduce muscle spasm.

i. Indications include joint pain, joint stiffness, soft tissue pain and inflammation, paresthesia, post-surgical pain relief, muscle spasm, and scar tissue pain.

b. Acupuncture with Electrical Stimulation is the use of electrical current (micro-amperage or milli-amperage) on the needles at the acupuncture site. It is used to increase effectiveness of the needles by continuous stimulation of the acupoint. Physiological effects (depending on location and settings) can include endorphin release for pain relief, reduction of inflammation, increased blood circulation, analgesia through interruption of pain stimulus, and muscle relaxation.

i. It is indicated to treat chronic pain conditions, radiating pain along a nerve pathway, muscle spasm, inflammation, scar tissue pain, and pain located in multiple sites.

c. Total Time Frames for Acupuncture and Acupuncture with Electrical Stimulation: Time frames are not meant to be applied to each of the above sections separately. The time frames are to be applied to all acupuncture treatments regardless of the type or combination of therapies being provided.

- i. Time to Produce Effect: three to six treatments.
- ii. Frequency: One to three times per week.
- iii. Optimum Duration: One to two months.
- iv. Maximum Duration: 14 treatments.

v. Any of the above acupuncture treatments may extend longer if objective functional gains can be documented or when symptomatic benefits facilitate progression in the patient's treatment program. Treatment beyond 14 treatments must be documented with respect to need and ability to facilitate positive symptomatic or

functional gains. Such care should be re-evaluated and documented with each series of treatments.

d. Other Acupuncture Modalities: Acupuncture treatment is based on individual patient needs and therefore treatment may include a combination of procedures to enhance treatment effect. Other procedures may include the use of heat, soft tissue manipulation/massage, and exercise. Refer to Active Therapy (Therapeutic Exercise) and Passive Therapy sections (Massage and Superficial Heat and Cold Therapy) for a description of these adjunctive acupuncture modalities and time frames.

2. Biofeedback is a form of behavioral medicine that helps patients learn self-awareness and self-regulation skills for the purpose of gaining greater control of their physiology, such as muscle activity, brain waves, and measures of autonomic nervous system activity. Electronic instrumentation is used to monitor the targeted physiology and then displayed or fed back to the patient visually, auditorially, or tactilely, with coaching by a biofeedback specialist. Biofeedback is provided by clinicians certified in biofeedback and/or who have documented specialized education, advanced training, or direct or supervised experience qualifying them to provide the specialized treatment needed (e.g., surface EMG, EEG, or other).

a. Treatment is individualized to the patient's work-related diagnosis and needs. Home practice of skills is required for mastery and may be facilitated by the use of home training tapes. The ultimate goal in biofeedback treatment is normalizing the physiology to the pre-injury status to the extent possible and involves transfer of learned skills to the workplace and daily life. Candidates for biofeedback therapy or training must be motivated to learn and practice biofeedback and self-regulation techniques.

b. Indications for biofeedback include individuals who are suffering from musculoskeletal injury in which muscle dysfunction or other physiological indicators of excessive or prolonged stress response affects and/or delays recovery. Other applications include training to improve self-management of emotional stress/pain responses such as anxiety, depression, anger, sleep disturbance, and other central and autonomic nervous system imbalances. Biofeedback is often utilized along with other treatment modalities.

- i. Time to Produce Effect: Three to four sessions.
- ii. Frequency: One to two times per week.
- iii. Optimum Duration: Five to six sessions.
- iv. Maximum Duration: 10 to 12 sessions.

Treatment beyond 12 sessions must be documented with respect to need, expectation, and ability to facilitate functional gains.

### 3. Bone-Growth Stimulators

a. Electrical. Pre-clinical and experimental literature has shown a stimulatory effect of externally applied electrical fields on the proliferation and calcification of osteoblasts and periosteal cells. All of the studies on bone

growth stimulators, however, have some methodological deficiencies and high-quality literature of electrical bone growth stimulation is lacking for lower extremity injuries.

i. These acceptable nonsurgical techniques include Capacitive Coupling (CC), which places skin electrodes on opposite sides of the bone being treated and Pulsed Electromagnetic Field (PEMF) which uses a current-carrying coil which induces a secondary electrical field in bone.

ii. There is insufficient evidence to conclude a benefit of electrical stimulation for delayed union, non-union, long bone fracture healing, fresh fractures, or tibial stress fractures.

b. Low-intensity Pulsed Ultrasound: There is some evidence that low-intensity pulsed ultrasound, applied by the patient at home and administered as initial treatment of the fracture, reduces the time required for cortical bridging in tibial fractures. Non-union and delayed unions were not included in these clinical trials. Possible indications for Low-Intensity Pulsed Ultrasound are non-unions or fractures that are expected to require longer healing time.

i. FDA approved bone-growth stimulators of any type may be appropriate for patients with non-union after initial fracture care or for patients with acute fractures or osteotomies who are at high risk for delayed union or non-union. Patients at high risk include, but are not limited to, smokers, diabetics, and those on chemotherapeutic agents or other long-term medication affecting bone growth. Due to lack of supporting scientific evidence, stimulators require prior authorization.

#### 4. Extracorporeal Shock Wave Therapy (ESWT)

a. Extracorporeal shock wave therapy (ESWT) delivers an externally applied acoustic pulse to the plantar fascia. It has been hypothesized that ESWT causes microtrauma to the fascia, inducing a repair process involving the formation of new blood vessels and delivery of nutrients to the affected area. High energy ESWT is delivered in one session and may be painful requiring some form of anesthesia. It is not generally recommended for the treatment of plantar heel pain due to increased cost when it is performed with conscious sedation. It may also be performed with local blocks. Low energy ESWT does not require anesthetics. It is given in a series of treatments, generally three sessions.

b. There is conflicting evidence concerning low energy ESWT for plantar heel pain. Focused ESWT concentrates the acoustic pulse on a single point in the heel, while radial ESWT distributes the pulse along the entire plantar fascia. Focused low energy ESWT has not been shown to produce clinically important reductions in plantar heel pain. There is some evidence that radial ESWT may reduce plantar pain more effectively than placebo, but a successful response may occur in only 60 percent of patients. There is some evidence supporting high-energy ESWT.

c. Low energy radial or high energy ESWT with local blocks are accepted treatments. It should only be used on patients who have had plantar pain for four months or more; have tried NSAIDs, ice, stretching exercises, shoe inserts; and have significant functional deficits. These patients should meet the indications for surgery found in heel spurs, plantar fascia pain. Tarsal tunnel syndrome should be ruled out. Peripheral vascular disease, lower extremity neuropathy and diabetes are all relative contraindications. Diagnostic testing may be needed to rule out these conditions.

i. Time to Effect: Two sessions.

ii. Optimum Duration: Three sessions one week or more apart.

iii. Maximum Duration: Treatment may be continued for up to five total sessions if functional improvement has been demonstrated after three treatment sessions. Functional improvement is preferably demonstrated using direct testing or functional scales validated in clinical research settings.

#### 5. Injections-Therapeutic

a. Description. Therapeutic injection procedures may play a significant role in the treatment of patients with lower extremity pain or pathology. Therapeutic injections involve the delivery of anesthetic and/or anti-inflammatory medications to the painful structure. Therapeutic injections have many potential benefits. Ideally, a therapeutic injection will: reduce inflammation in a specific target area; relieve secondary muscle spasm; allow a break from pain; and support therapy directed to functional recovery. Diagnostic and therapeutic injections should be used early and selectively to establish a diagnosis and support rehabilitation. If injections are overused or used outside the context of a monitored rehabilitation program, they may be of significantly less value.

b. Indications. Diagnostic injections are procedures which may be used to identify pain generators or pathology. For additional specific clinical indications see Specific Lower Extremity Injury Diagnosis, Testing and Treatment.

c. Special Considerations. The use of injections has become progressively sophisticated. Each procedure considered has an inherent risk, and risk versus benefit should be evaluated when considering injection therapy. In addition, all injections must include sterile technique.

d. Contraindications. General contraindications include local or systemic infection, bleeding disorders, allergy to medications used, and patient refusal. Specific contraindications may apply to individual injections.

e. Joint Injections: are generally accepted, well-established procedures that can be performed as analgesic or anti-inflammatory procedures.

i. Time to Produce Effect: Immediate with local anesthesia, or within three days if no anesthesia.

ii. Optimum Duration: Usually one to two injections is adequate.

iii. Maximum Duration: Not more than three to four times annually.

iv. Steroid injections should be used cautiously in diabetic patients. Diabetic patients should be reminded to check their blood-glucose level at least twice daily for two weeks post-injections.

f. Soft Tissue Injections: include bursa and tendon insertions. Injections under significant pressure should be avoided as the needle may be penetrating the tendon. Injection into the tendon can cause tendon degeneration, tendon breakdown, or rupture. Injections should be minimized for patients under 30 years of age.

i. When performing tendon insertion injections, the risk of tendon rupture should be discussed with the patient and the need for restricted duty emphasized.

(a). Time to Produce Effect: Immediate with local anesthesia, or within three days if no anesthesia.

(b). Optimum Duration: Usually one to two injections is adequate.

(c). Maximum Duration: Not more than three to four times annually.

ii. Steroid injections should be used cautiously in diabetic patients. Diabetic patients should be reminded to check their blood-glucose level at least twice daily for two weeks post-injections.

g. Trigger Point Injections: although generally accepted, have only rare indications in the treatment of lower extremity disorders. Therefore, the OWCA does not recommend their routine use in the treatment of lower extremity injuries.

i. Description. Trigger point treatment can consist of dry needling or injection of local anesthetic with or without corticosteroid into highly localized, extremely sensitive bands of skeletal muscle fibers that produce local and referred pain when activated. Medication is injected in a four-quadrant manner in the area of maximum tenderness. Injection efficacy can be enhanced if injections are immediately followed by myofascial therapeutic interventions, such as vapo-coolant spray and stretch, ischemic pressure massage (myotherapy), specific soft tissue mobilization and physical modalities. There is conflicting evidence regarding the benefit of trigger point injections. A truly blinded study comparing dry needle treatment of trigger points is not feasible. There is no evidence that injection of medications improves the results of trigger-point injections. Needling alone may account for some of the therapeutic response.

ii. There is no indication for conscious sedation for patients receiving trigger point injections. The patient must be alert to help identify the site of the injection.

iii. Indications. Trigger point injections may be used to relieve myofascial pain and facilitate active therapy

and stretching of the affected areas. They are to be used as an adjunctive treatment in combination with other treatment modalities such as functional restoration programs. Trigger point injections should be utilized primarily for the purpose of facilitating functional progress. Patients should continue with a therapeutic exercise program as tolerated throughout the time period they are undergoing intensive myofascial interventions. Myofascial pain is often associated with other underlying structural problems, and any abnormalities need to be ruled out prior to injection.

iv. Trigger point injections are indicated in those patients where well circumscribed trigger points have been consistently observed, demonstrating a local twitch response, characteristic radiation of pain pattern and local autonomic reaction, such as persistent hyperemia following palpation. Generally, these injections are not necessary unless consistently observed trigger points are not responding to specific, noninvasive, myofascial interventions within approximately a six week time frame.

v. Complications. Potential but rare complications of trigger point injections include infection, anaphylaxis, neurapraxia, and neuropathy. If corticosteroids are injected in addition to local anesthetic, there is a risk of developing local myopathy. Severe pain on injection suggests the possibility of an intraneural injection, and the needle should be immediately repositioned.

(a). Time to Produce Effect: Local anesthetic 30 minutes; no anesthesia 24 to 48 hours.

(b). Frequency: Weekly, suggest no more than four injection sites per session per week to avoid significant post-injection soreness.

(c). Optimum Duration: Four Weeks.

(d). Maximum Duration: Eight weeks. Occasional patients may require two to four repetitions of trigger point injection series over a one to two year period.

h. Viscosupplementation/Intracapsular Acid Salts: is an accepted form of treatment for osteoarthritis or degenerative changes in the knee joint. There is good evidence that intra-articular hyaluronic acid injections have only a small effect on knee pain and function. Therefore, the patient and treating physician should identify functional goals and the likelihood of achieving improved ability to perform activities of daily living or work activities with injections versus other treatments. The patient should agree to comply with the treatment plan including home exercise. These injections may be considered an alternative in patients who have failed non-operative treatment and surgery is not an option, particularly, if non-steroidal anti-inflammatory drug treatment is contraindicated or has been unsuccessful. Viscosupplementation is not recommended for patients with severe osteoarthritis who are surgical candidates. Its efficacy beyond six months is not well-established. There is no evidence that one product significantly outperforms another, prior authorization is required to approve product choice and for repeat series of injections.

i. One injection of 6 ml of Hylan G-F 20 may be effective and is an option for knee injections.

ii. Viscosupplementation is not recommended for ankle osteoarthritis due to the small effect size documented in knee conditions and the lack of evidence supporting its use in the ankle. Viscosupplementation is not recommended for hip arthritis given the probable superiority of corticosteroid injections. In rare cases a patient with significant hip osteoarthritis who does not qualify for surgical intervention may try viscosupplementation. It should be done with ultrasound or fluoroscopic guidance and will not necessarily require a series of three injections. The patient may choose to have repeat injections when the first injection was successful.

(a). Time to Produce Effect: After one series or one injection as discussed above, there must be a functional gain lasting three months to justify repeat injections.

(b). Frequency: One injection or one series (three to five injections generally spaced one week apart).

(c). Optimum/Maximum Duration: Varies. Efficacy beyond six months is not well-established.

i. Prolotherapy (also known as sclerotherapy) consists of peri-articular injections of hypertonic dextrose with or without phenol with the goal of inducing an inflammatory response that will recruit cytokine growth factors involved in the proliferation of connective tissue. Advocates of prolotherapy propose that these injections will alleviate complaints related to joint laxity by promoting the growth of connective tissue and stabilizing the involved joint.

i. Laboratory studies may lend some biological plausibility to claims of connective tissue growth, but high quality published clinical studies are lacking. The dependence of the therapeutic effect on the inflammatory response is poorly defined, raising concerns about the use of conventional anti-inflammatory drugs when proliferant injections are given. The evidence in support of prolotherapy is insufficient and therefore, its use is not recommended in lower extremity injuries.

6. Jobsite Alteration. Early evaluation and training of body mechanics are essential for every injured worker. Risk factors to be addressed include: repetitive work, lifting, and forces that have an impact on the lower extremity. In some cases, this requires a jobsite evaluation. There is no single factor or combination of factors that is proven to prevent or ameliorate lower extremity pain, but a combination of ergonomic and psychosocial factors are generally considered to be important. Physical factors that may be considered include use of force, repetitive work, squatting, climbing, kneeling, crouching, crawling, prolonged standing, walking a distance or on uneven surfaces, jumping, running, awkward positions requiring use of force, and lower extremity vibration. Psychosocial factors to be considered include pacing, degree of control over job duties, perception of job stress, and supervisory support.

a. The job analysis and modification should include input from the employee, employer, and a medical professional familiar with work place evaluation. An ergonomist may also provide useful information. The employee must be observed performing all job functions in order for the jobsite analysis to be valid. Periodic follow-up is recommended to evaluate effectiveness of the intervention and need for additional ergonomic changes.

i. Ergonomic Changes may be made to modify the hazards identified. In addition, workers should be counseled to vary tasks throughout the day. When possible, employees performing repetitive tasks should take 15 to 30 second breaks every 10 to 20 minutes, or 5-minute breaks every hour. Mini-breaks should include stretching exercises.

ii. Interventions should consider engineering controls (e.g., mechanizing the task, changing the tool used, or adjusting the jobsite), or administrative controls (e.g., adjusting the time an individual performs the task).

7. Medications and medical management. Use of medications will vary widely due to the spectrum of injuries from simple strains to complicated fractures. A thorough medication history, including use of alternative and over-the-counter medications, should be performed at the time of the initial visit and updated periodically. Treatment for pain control is initially accomplished with acetaminophen and/or NSAIDs. The patient should be educated regarding the interaction with prescription and over-the-counter medications as well as the contents of over-the-counter herbal products.

a. Nonsteroidal anti-inflammatory drugs (NSAIDs) and acetaminophen are useful in the treatment of injuries associated with degenerative joint disease and/or inflammation. These same medications can be used for pain control.

b. Topical agents can be beneficial for pain management in lower extremity injuries. This includes topical capsaicin, nonsteroidals, as well as topical iontophoretics/phonophoretics, such as steroid creams and lidocaine.

c. Glucosamine and chondroitin are sold in the United States as dietary supplements. Their dosage, manufacture, and purity are not regulated by the Food and Drug Administration. For moderate to severe knee osteoarthritis, there is good evidence for the effectiveness of a pharmaceutical grade combination of 500 mg glucosamine hydrochloride and 400 mg chondroitin sulfate three times per day. Effectiveness for mild disease is unknown. Recent literature suggests that chondroitin sulfate in a dose of 800 mg once daily may reduce the rate of joint degradation as demonstrated by joint space loss on serial x-rays.

d. For mild-to-moderate osteoarthritis confined to the hip, there is good evidence that a pharmaceutical-grade glucosamine sulfate is unlikely to produce a clinically significant improvement in pain and joint function.

e. When osteoarthritis is identified as a contributing factor to a work-related injury, pharmaceutical grade



glucosamine and chondroitin may be tried. Long-term coverage for these medications would fall under Workers' Compensation only when the arthritic condition is primarily related to the work injury.

f. S-adenosyl methionine (SAM-e), like glucosamine and chondroitin, is sold as a dietary supplement in the United States, with a similar lack of standard preparations of dose and manufacture. There is some evidence that a pharmaceutical-grade SAM-e is as effective as celecoxib in improving pain and function in knee osteoarthritis, but its onset of action is slower. Studies using liquid chromatography have shown that it may lose its potency after several weeks of storage. In addition, SAM-e has multiple additional systemic effects. It is not currently recommended due to lack of availability of pharmaceutical quality, systemic effects, and loss of potency with storage.

i. The following are listed in alphabetical order.

(a). Acetaminophen: is an effective analgesic with antipyretic but not anti-inflammatory activity. Acetaminophen is generally well tolerated, causes little or no gastrointestinal irritation and is not associated with ulcer formation. Acetaminophen has been associated with liver toxicity in overdose situations or in chronic alcohol use. Patients may not realize that many over-the-counter preparations may contain acetaminophen. The total daily dose of acetaminophen is recommended not to exceed 2250 mg per 24 hour period, from all sources, including narcotic-acetaminophen combination preparations.

(i). Optimal Duration: 7 to 10 days.

(ii). Maximum Duration: Chronic use as indicated on a case-by-case basis. Use of this substance long-term for three days per week or greater may be associated with rebound pain upon cessation.

b. Bisphosphonates may be used for those qualifying under osteoporosis guidelines. Long-term use for the purpose of increasing prosthetic fixation is not recommended as long-term improvement in fixation is not expected. See Osteoporosis Management Section below.

c. Deep Venous Thrombosis Prophylaxis is a complex issue involving many variables such as individual patient characteristics, the type of surgery, anesthesia used and agent(s) used for prophylaxis. Final decisions regarding prophylaxis will depend on the surgeon's clinical judgment. The following are provided as generally accepted concepts regarding prophylaxis at the time of writing of these guidelines.

i. All patients undergoing lower extremity surgery or prolonged lower extremity immobilization should be evaluated for elevated risk for DVT and should receive education on prevention. Possible symptoms should be discussed. Patients at higher risk than the normal population include, but are not limited to, those with known hypercoagulable states and those with previous pulmonary embolism or DVT. Those considered at higher risk for bleeding, which may alter thromboprophylaxis protocols,

include patients with a history of a bleeding disorder, recent gastrointestinal bleed, or hemorrhagic stroke.

ii. There is no evidence to support mandatory prophylaxis for all patients who are immobilized or undergo lower extremity procedures, outside of hip or knee arthroplasties or hip fracture repair.

iii. Hip and knee arthroplasties and hip fracture repair are standard risk factors requiring thromboprophylaxis. Commonly used agents are low molecular weight heparin, low dose un-fractionated heparin (LDUH), synthetic pentasaccharide fondaparinux, or warfarin. If aspirin is used, it should be accompanied by aggressive mechanical prophylaxis.

iv. All patients should be mobilized as soon as possible after surgery. Mechanical prophylaxis such as pneumatic devices that are thigh calf, calf only, or foot pumps may be considered immediately post-operatively and/or until the patient is discharged home. Thigh length or knee high graduated compression stockings are used for most patients. With prolonged prophylaxis, lab tests must be drawn regularly. These may be accomplished with home health care or outpatient laboratories when appropriate.

d. Minor Tranquilizer/Muscle Relaxants are appropriate for muscle spasm, mild pain and sleep disorders. When prescribing these agents, physicians must seriously consider side effects of drowsiness or dizziness and the fact that benzodiazepines may be habit-forming.

i. Optimal Duration: One week.

ii. Maximum Duration: Four weeks.

e. Narcotics: should be primarily reserved for the treatment of severe lower extremity pain. There are circumstances where prolonged use of narcotics is justified based upon specific diagnosis, and in these cases, it should be documented and justified. In mild-to-moderate cases of lower extremity pain, narcotic medication should be used cautiously on a case-by-case basis. Adverse effects include respiratory depression, the development of physical and psychological dependence, and impaired alertness.

i. Narcotic medications should be prescribed with strict time, quantity, and duration guidelines, and with definitive cessation parameters. Pain is subjective in nature and should be evaluated using a pain scale and assessment of function to rate effectiveness of the narcotic prescribed. Any use beyond the maximum duration should be documented and justified based on the diagnosis and/or invasive procedures.

(a). Optimal Duration: Three to seven days.

(b). Maximum Duration: Two weeks. Use beyond two weeks is acceptable in appropriate cases. Refer to Chronic Pain Guidelines which gives a detailed discussion regarding medication use in chronic pain management. When prescribing beyond the maximum duration, it is recommended physicians access the Colorado PDMP (Prescription Drug Monitoring Program). This system allows

the prescribing physician to see all controlled substances prescribed by other physicians for an individual patient.

f. **Nonsteroidal Anti-Inflammatory Drugs (NSAIDs):** are useful for pain and inflammation. In mild cases, they may be the only drugs required for analgesia. There are several classes of NSAIDs, and the response of the individual injured worker to a specific medication is unpredictable. For this reason, a range of NSAIDs may be tried in each case with the most effective preparation being continued. Patients should be closely monitored for adverse reactions. The US Food and Drug Administration advise that many NSAIDs may cause an increased risk of serious cardiovascular thrombotic events, myocardial infarction, and stroke, which can be fatal. Naproxen sodium does not appear to be associated with increased risk of vascular events. Administration of proton pump inhibitors, histamine 2 blockers, or prostaglandin analog misoprostol along with these NSAIDs may reduce the risk of duodenal and gastric ulceration but do not impact possible cardiovascular complications. Due to the cross-reactivity between aspirin and NSAIDs, NSAIDs should not be used in aspirin-sensitive patients, and should be used with caution in all asthma patients. NSAIDs are associated with abnormal renal function, including renal failure, as well as, abnormal liver function. Certain NSAIDs may have interactions with various other medications. Individuals may have adverse events not listed above. Intervals for metabolic screening are dependent upon the patient's age, general health status and should be within parameters listed for each specific medication. Complete Blood Count (CBC) and liver and renal function should be monitored at least every six months in patients on chronic NSAIDs and initially when indicated.

i. NSAIDs may be used for pain management after joint replacement. They have also been used to reduce heterotopic ossification after arthroplasty. NSAIDs do reduce the radiographically documented heterotopic ossification in this setting, but there is some evidence that they do not improve functional outcomes and they may increase the risk of bleeding events in the post-operative period. Their routine use for prevention of heterotopic bone formation is not recommended.

(a). **Non-Selective Nonsteroidal Anti-Inflammatory Drugs:** Includes NSAIDs and acetylsalicylic acid (aspirin). Serious GI toxicity, such as bleeding, perforation, and ulceration can occur at any time, with or without warning symptoms in patients treated with traditional NSAIDs. Physicians should inform patients about the signs and/or symptoms of serious gastrointestinal toxicity and what steps to take if they occur. Anaphylactoid reactions may occur in patients taking NSAIDs. NSAIDs may interfere with platelet function. Fluid retention and edema have been observed in some patients taking NSAIDs.

i. Optimal Duration: One week.

ii. Maximum Duration: One year. Use of these substances long-term (Three days per week or greater) is associated with rebound pain upon cessation.

b. **Selective Cyclo-oxygenase-2 (COX-2) Inhibitors:**

i. COX-2 inhibitors are more recent NSAIDs and differ in adverse side effect profiles from the traditional NSAIDs. The major advantages of selective COX-2 inhibitors over traditional NSAIDs are that they have less gastrointestinal toxicity and no platelet effects. COX-2 inhibitors can worsen renal function in patients with renal insufficiency, thus renal function may need monitoring.

ii. COX-2 inhibitors should not be first-line for low risk patients who will be using a NSAID short-term but are indicated in select patients for whom traditional NSAIDs are not tolerated. Serious upper GI adverse events can occur even in asymptomatic patients. Patients at high risk for GI bleed include those who use alcohol, smoke, are older than 65, take corticosteroids or anti-coagulants, or have a longer duration of therapy. Celecoxib is contraindicated in sulfonamide allergic patients.

(a). Optimal Duration: 7 to 10 days.

(b). Maximum Duration: Chronic use is appropriate in individual cases. Use of these substances long-term (Three days per week or greater) is associated with rebound pain upon cessation.

g. **Oral Steroids:** have limited use but are accepted in cases requiring potent anti-inflammatory drug effect in carefully selected patients. A one-week regime of steroids may be considered in the treatment of patients who have arthritic flare-ups with significant inflammation of the joint. The physician must be fully aware of potential contraindications for the use of all steroids such as hypertension, diabetes, glaucoma, peptic ulcer disease, etc., which should be discussed with the patient.

i. Optimal Duration: Three to seven days.

ii. Maximum Duration: Seven days.

h. **Osteoporosis Management.** All patients with conditions which require bone healing, especially those over 50, should be encouraged to ingest at least 1200 mg of Calcium and 800 IU of Vitamin D per day. There is some evidence that, for women in the older age group (58 to 88) with low hip bone density, greater callus forms for those who adhere to these recommendations than those who do not. Although the clinical implications of this are not known, there is greater non-union in this age group and thus, coverage for these medications during the fracture healing time period is recommended. At this time there is no evidence that bisphosphonates increase acute fracture healing.

i. Female patients over 65 should be referred for an osteoporosis evaluation if one has not been completed the previous year. Patients who have been on prednisone at a dose of 5 to 7.5 mg for more than 3 months should be evaluated for glucocorticoid induced osteoporosis. An osteoporosis evaluation may be considered for males who: are over 70, are physically inactive, have previous fragility fracture, have a BMI less than 20, or have been hypogonadal

for 5 years. Evaluation may also be considered for patients on medications that can cause bone loss, patients who have suffered a fracture due to a low-impact fall or with minimum to no provocation, and women under 65 with one of the following: menopause before 40, current smoker, or body mass index less than 20. Low body weight appears to be the best predictor of osteoporosis in women younger than 65. In one adequate study, all patients aged 50 to 75 referred to an orthopaedic department for treatment of wrist, vertebral, proximal humerus, or hip fractures received bone mass density testing. 97 percent of patients had either osteoporosis (45 percent) or osteopenia (42 percent). Referral is important to prevent future fractures in these groups. Long-term care for osteoporosis is not covered under workers compensation even though it may be discovered due to an injury-related acute fracture.

i. Psychotropic/Anti-anxiety/Hypnotic Agents may be useful for treatment of mild and chronic pain, dysesthesias, sleep disorders, and depression. Post-operative patients may receive medication to assure normal sleep cycles. Antidepressant medications, such as tricyclics and Selective Serotonin Reuptake Inhibitors (SSRIs), are useful for affective disorder and chronic pain management. Tricyclic antidepressant agents, in low dose, are useful for chronic pain but have more frequent side effects.

i. Anti-anxiety medications are best used for short-term treatment (i.e., less than six months). Accompanying sleep disorders are best treated with sedating antidepressants prior to bedtime. Frequently, combinations of the above agents are useful. As a general rule, physicians should access the patient's prior history of substance abuse or depression prior to prescribing any of these agents.

ii. Due to the habit-forming potential of the benzodiazepines and other drugs found in this class, they are not routinely recommended. Refer to the Chronic Pain Guidelines which give a detailed discussion regarding medication use in chronic pain management.

(a). Optimal Duration: One to six months.

(b). Maximum Duration: 6 to 12 months, with monitoring.

j. Topical Drug Delivery: Creams and patches may be an alternative treatment of localized musculoskeletal disorders. It is necessary that all topical agents be used with strict instructions for application as well as the maximum number of applications per day to obtain the desired benefit and avoid potential toxicity. As with all medications, patient selection must be rigorous to select those patients with the highest probability of compliance. Refer to "Iontophoresis" in the Passive Therapy of this section for information regarding topical iontophoretic agents.

i. Topical Salicylates and Nonsalicylates: have been shown to be effective in relieving pain in acute and chronic musculoskeletal conditions. Topical salicylate and nonsalicylates achieve tissue levels that are potentially therapeutic, at least with regard to COX inhibition. Other than local skin reactions, the side effects of therapy are

minimal, although not non-existent, and the usual contraindications to use of these compounds needs to be considered. Local skin reactions are rare and systemic effects were even less common. Their use in patients receiving warfarin therapy may result in alterations in bleeding time. Overall, the low level of systemic absorption can be advantageous; allowing the topical use of these medications when systemic administration is relatively contraindicated such as is the case in patients with hypertension, cardiac failure, or renal insufficiency.

(a). There is no evidence that topical agents are more or less effective than oral medications.

(i). Optimal Duration: One week.

(ii). Maximal Duration: Two weeks per episode.

ii. Capsaicin: is another medication option for topical drug use in lower extremity injury. Capsaicin offers a safe and effective alternative to systemic NSAID therapy. Although it is quite safe, effective use of capsaicin is limited by the local stinging or burning sensation that typically dissipates with regular use, usually after the first 7 to 10 days of treatment. Patients should be advised to apply the cream on the affected area with a plastic glove or cotton applicator and to avoid inadvertent contact with eyes and mucous membranes.

(a). Optimal Duration: One week.

(b). Maximal Duration: Two weeks per episode.

iii. Iontophoretic Agents: Refer to "Iontophoresis," under Passive Therapy of this section.

k. Tramadol is useful in relief of lower extremity pain and has been shown to provide pain relief equivalent to that of commonly prescribed NSAIDs. Tramadol is an atypical opioid with norepinephrine and serotonin reuptake inhibition. It is not considered a controlled substance in the U.S. Although Tramadol may cause impaired alertness, it is generally well tolerated, does not cause gastrointestinal ulceration, or exacerbate hypertension or congestive heart failure. Tramadol should be used cautiously in patients who have a history of seizures or who are taking medication that may lower the seizure threshold, such as MAO inhibitors, SSRIs, and tricyclic antidepressants. This medication has physically addictive properties and withdrawal may follow abrupt discontinuation and is not recommended for patients with prior opioid addiction.

i. Optimal Duration: Three to seven days.

ii. Maximum Duration: Two weeks. Use beyond two weeks is acceptable in appropriate cases.

## 8. Occupational Rehabilitation Programs

a. Interdisciplinary: programs are well-established treatment for patients with sub-acute and functionally impairing cervical spine pain. They are characterized by a variety of disciplines that participate in the assessment, planning, and/or implementation of an injured workers program with the goal for patients to gain full or optimal

function and return to work. There should be close interaction and integration among the disciplines to ensure that all members of the team interact to achieve team goals. Programs should include cognitive-behavioral therapy as there is good evidence for its effectiveness in patients with chronic low back pain and it is probably effective in cervical spine pain. These programs are for patients with greater levels of disability, dysfunction, deconditioning and psychological involvement. For patients with chronic pain, refer to the Chronic Pain Disorder Medical Treatment Guidelines.

i. Work Hardening

(a). Work Hardening is an interdisciplinary program addressing a patient's employability and return to work. It includes a progressive increase in the number of hours per day that a patient completes work simulation tasks until the patient can tolerate a full workday. This is accomplished by addressing the medical, psychological, behavioral, physical, functional, and vocational components of employability and return-to-work.

(b). This can include a highly structured program involving a team approach or can involve any of the components thereof. The interdisciplinary team should, at a minimum, be comprised of a qualified medical director who is board certified with documented training in occupational rehabilitation; team physicians having experience in occupational rehabilitation; occupational therapy; physical therapy; case manager; and psychologist. As appropriate, the team may also include: chiropractor, RN, vocational specialist or Certified Biofeedback Therapist.

- (i). Length of Visit: up to eight hours/day
- (ii). Frequency: Two to five visits per week
- (iii). Optimal Duration: Two to four weeks
- (iv). Maximum Duration: Six weeks.

Participation in a program beyond six weeks must be documented with respect to need and the ability to facilitate positive symptomatic or functional gains.

b. Non-Interdisciplinary. These generally accepted programs are work-related, outcome-focused, individualized treatment programs. Objectives of the program include, but are not limited to, improvement of cardiopulmonary and neuromusculoskeletal functions (strength, endurance, movement, flexibility, stability, and motor control functions), patient education, and symptom relief. The goal is for patients to gain full or optimal function and return to work. The service may include the time-limited use of passive modalities with progression to achieve treatment and/or simulated/real work.

i. Work Conditioning. These programs are usually initiated once reconditioning has been completed but may be offered at any time throughout the recovery phase. It should be initiated when imminent return of a patient to modified- or full-duty is not an option, but the prognosis for returning the patient to work at completion of the program is at least fair to good.

- (a). Length of visit: One to two hours per day.
- (b). Frequency: Two to five visits per week.
- (c). Optimum Duration: Two to four weeks.
- (d). Maximum Duration: Six weeks.

Participation in a program beyond six weeks must be documented with respect to need and the ability to facilitate positive symptomatic or functional gains.

ii. Work Simulation is a program where an individual completes specific work-related tasks for a particular job and return-to-work. Use of this program is appropriate when modified duty can only be partially accommodated in the work place, when modified duty in the work place is unavailable, or when the patient requires more structured supervision. The need for work place simulation should be based upon the results of a Functional Capacity Evaluation and/or Jobsite Analysis.

- (a). Length of visit: two to six hours per day.
- (b). Frequency: two to five visits per week.
- (c). Optimum Duration: two to four weeks.
- (d). Maximum Duration: Six weeks.

Participation in a program beyond six weeks must be documented with respect to need and the ability to facilitate positive symptomatic or functional gains.

9. Orthotics and prosthetics

a. Fabrication/Modification of Orthotics: would be used when there is need to normalize weight-bearing, facilitate better motion response, stabilize a joint with insufficient muscle or proprioceptive/reflex competencies, to protect subacute conditions as needed during movement, and correct biomechanical problems. Footwear modifications may be necessary for work shoes and everyday shoes. Replacement is needed every six months to one year. For specific types of orthotics/prosthetics see Section e, "Specific Lower Extremity Injury Diagnosis, Testing and Treatment."

- i. Time to Produce Effect: One to three sessions (includes wearing schedule and evaluation).
- ii. Frequency: One to two times per week.
- iii. Optimum/Maximum Duration: Over a period of approximately four to six weeks for casting, fitting, and re-evaluation.

b. Orthotic/Prosthetic Training: is the skilled instruction (by qualified providers) in the proper use of orthotic devices and/or prosthetic limbs including stump preparation, donning and doffing limbs, instruction in wearing schedule and orthotic/prosthetic maintenance training. Training can include gait, mobility, transfer and self-care techniques.

- i. Time to Produce Effect: Two to six sessions.
- ii. Frequency: Three times per week.

iii. Optimum/Maximum Duration: two to four months.

c. Splints or Adaptive Equipment—design, fabrication and/or modification indications include the need to control neurological and orthopedic injuries for reduced stress during functional activities and modify tasks through instruction in the use of a device or physical modification of a device, which reduces stress on the injury. Equipment should improve safety and reduce risk of re-injury. This includes high and low technology assistive options such as workplace modifications, crutch or walker training, and self-care aids.

i. Time to Produce Effect: Immediate.

ii. Frequency: One to three sessions or as indicated to establish independent use.

iii. Optimum/Maximum Duration: One to three sessions.

10. Patient Education. No treatment plan is complete without addressing issues of individual and/or group patient education as a means of prolonging the beneficial effects of treatment, as well as facilitating self-management of symptoms and injury prevention. The patient should be encouraged to take an active role in the establishment of functional outcome goals. They should be educated on their specific injury, assessment findings, and plan of treatment. Instruction on proper body mechanics and posture, positions to avoid, self-care for exacerbation of symptoms, and home exercise should also be addressed.

a. Time to Produce Effect: Varies with individual patient.

b. Frequency: Should occur at each visit.

11. Personality/psychosocial/psychiatric/psychological intervention. Psychosocial treatment is a generally accepted, widely used and well-established intervention. This group of therapeutic and diagnostic modalities includes, but is not limited to: individual counseling, group therapy, stress management, psychosocial crises intervention, hypnosis and meditation. Any screening or diagnostic workup should clarify and distinguish between pre-existing versus aggravated versus purely causative psychological conditions. Psychosocial intervention is recommended as an important component in the total management program that should be implemented as soon as the problem is identified. This can be used alone or in conjunction with other treatment modalities. Providers treating patients with chronic pain should refer to the OWCA's Chronic Pain Disorder Medical Treatment Guidelines.

a. Time to Produce Effect: Two to four weeks.

b. Frequency: One to three times weekly for the first four weeks (excluding hospitalization, if required), decreasing to one to two times per week for the second month. Thereafter, two to four times monthly.

c. Optimum Duration: Six weeks to three months.

d. Maximum Duration: 3 to 12 months. Counseling is not intended to delay but to enhance functional recovery. For select patients, longer supervised treatment may be required, and if further counseling beyond three months is indicated, documentation addressing which pertinent issues are pre-existing versus aggravated versus causative, as well as projecting a realistic functional prognosis, should be provided by the authorized treating provider every four to six weeks during treatment.

12. Restriction of activities varies according to the specific diagnosis and the severity of the condition. Job modification/modified duty are frequently required to avoid exacerbation of the injured lower extremity. Complete work cessation should be avoided, if possible, since it often further aggravates the pain presentation. Modified return-to-work is almost always more efficacious and rarely contraindicated in the vast majority of injured workers with lower extremity injuries.

13. Return-to-Work. Early return-to-work should be a prime goal in treating occupational injuries given the poor return-to-work prognosis for an injured worker who has been out of work for more than six months. It is imperative that the patient be educated regarding the benefits of return-to-work, work restrictions, and follow-up if problems arise. When attempting to return a patient to work after a specific injury, clear objective restrictions of activity level should be made. An accurate job description with detailed physical duty restrictions is often necessary to assist the physician in making return-to-work recommendations. This may require a jobsite evaluation.

a. Employers should be prepared to offer transitional work. This may consist of temporary work in a less demanding position, return to the regular job with restrictions, or gradual return to the regular job. Company policies which encourage return-to-work with positive communication are most likely to have decreased worker disability.

b. Return-to-work is defined as any work or duty that the patient is able to perform safely. It may not be the patient's regular work. Due to the large spectrum of injuries of varying severity and varying physical demands in the work place, it is not possible to make specific return-to-work guidelines for each injury. Therefore, the OWCA recommends the following:

c. Compliance with Activity Restrictions: In some cases, compliance with restriction of activity levels may require a complete jobsite evaluation, a functional capacity evaluation (FCE), or other special testing. Refer to the "Special Tests" section of these guidelines.

d. Establishment of a Return-to-Work Status: Ascertaining a return-to-work status is part of medical care, should be included in the treatment and rehabilitation plan, and addressed at every visit. A description of daily activity limitations is part of any treatment plan and should be the basis for restriction of work activities. In most cases non-surgical the patient should be able to return to work in some capacity or in an alternate position consistent with medical

treatment within several days unless there are extenuating circumstances. Injuries requiring more than two weeks off work should be thoroughly documented (Some of these diagnoses are listed in Specific Lower Extremity Injury Diagnosis, Testing and Treatment).

e. Establishment of Activity Level Restrictions: Communication is essential between the patient, employer and provider to determine appropriate restrictions and return-to-work dates. It is the responsibility of the physician to provide clear concise restrictions, and it the employer's responsibility to determine if temporary duties can be provided within the restrictions. For lower extremity injuries, the following should be addressed when describing the patient's activity level:

- i. lower body postures such as squatting, kneeling, crawling, stooping, or climbing, including duration and frequency;
- ii. ambulatory level for distance, frequency and terrain;
- iii. static and dynamic standing including duration and frequency;
- iv. ability to maintain balance;
- v. use of adaptive devices, including cane and walker, to accomplish basic job duties.

14. Therapy-Active. The following active therapies are widely used and accepted methods of care for a variety of work-related injuries. They are based on the philosophy that therapeutic exercise and/or activity are beneficial for restoring flexibility, strength, endurance, function, range-of-motion, and can alleviate discomfort. Active therapy requires an internal effort by the individual to complete a specific exercise or task. This form of therapy requires supervision from a therapist or medical provider such as verbal, visual and/or tactile instruction(s). At times, the provider may help stabilize the patient or guide the movement pattern but the energy required to complete the task is predominately executed by the patient.

a. Patients should be instructed to continue active therapies at home as an extension of the treatment process in order to maintain improvement levels. Follow-up visits to reinforce and monitor progress and proper technique are recommended. Home exercise can include exercise with or without mechanical assistance or resistance and functional activities with assistive devices.

i. The following active therapies are listed in alphabetical order:

(a). Activities of Daily Living (ADL) are well-established interventions which involve instruction, active-assisted training, and/or adaptation of activities or equipment to improve a person's capacity in normal daily activities such as self-care, work re-integration training, homemaking, and driving.

(i). Time to Produce Effect: Four to five treatments.

(ii). Frequency: Three to five times per week.

(iii). Optimum Duration: Four to six weeks.

(iv). Maximum Duration: Six weeks.

(b). Aquatic Therapy is a well-accepted treatment which consists of the therapeutic use of aquatic immersion for therapeutic exercise to promote ROM, flexibility, core stabilization, endurance, strengthening, body mechanics, and pain management. Aquatic therapy includes the implementation of active therapeutic procedures in a swimming or therapeutic pool. The water provides a buoyancy force that lessens the amount of force gravity applies to the body. The decreased gravity effect allows the patient to have a mechanical advantage and more likely to have a successful trial of therapeutic exercise. Studies have shown that the muscle recruitment for aquatic therapy versus similar non-aquatic motions is significantly less. Because there is always a risk of recurrent or additional damage to the muscle tendon unit after a surgical repair, aquatic therapy may be preferred by surgeons to gain early return of ROM. In some cases the patient will be able to do the exercises unsupervised after the initial supervised session. Parks and recreation contacts may be used to locate less expensive facilities for patients. Indications include:

(i). Post-operative therapy as ordered by the surgeon; or

(ii). Intolerance for active land-based or full-weight-bearing therapeutic procedures; or

(iii). Symptoms that are exacerbated in a dry environment; and

(iv). Willingness to follow through with the therapy on a regular basis.

(v). The pool should be large enough to allow full extremity ROM and fully erect posture. Aquatic vests, belts, snorkels, and other devices may be used to provide stability, balance, buoyancy, and resistance.

[a]. Time to Produce Effect: Four to five treatments.

[b]. Frequency: Three to five times per week.

[c]. Optimum Duration: Four to six weeks.

[d]. Maximum Duration: Eight weeks.

(vi). A self-directed program is recommended after the supervised aquatics program has been established, or alternatively a transition to a self-directed dry environment exercise program.

(vii). There is some evidence that for osteoarthritis of the hip or knee, aquatic exercise probably slightly reduces pain and slightly improves function over three months.

(c). Functional Activities are the use of therapeutic activity to enhance mobility, body mechanics, employability, coordination, balance, and sensory motor integration.

(i). Time to Produce Effect: Four to five treatments

(ii). Frequency: Three to five times per week.

(iii). Optimum Duration: Four to six weeks.

(iv). Maximum Duration: Six weeks

(d). Functional Electrical Stimulation is the application of electrical current to elicit involuntary or assisted contractions of atrophied and/or impaired muscles. Indications include muscle atrophy, weakness, sluggish muscle contraction, neuromuscular dysfunction or peripheral nerve lesion. Indications also may include an individual who is precluded from active therapy.

(i). Time to Produce Effect: Two to six treatments.

(ii). Frequency: Three times per week.

(iii). Optimum Duration: Eight weeks.

(iv). Maximum Duration: Eight weeks. If beneficial, provide with home unit. Home use is not recommended for neuromuscularly intact patients.

(e). Gait Training is crutch walking, cane or walker instruction to a person with lower extremity injury or surgery. Indications include the need to promote normal gait pattern with assistive devices; instruct in the safety and proper use of assistive devices; instruct in progressive use of more independent devices (i.e., platform-walker, to walker, to crutches, to cane); instruct in gait on uneven surfaces and steps (with and without railings) to reduce risk of fall, or loss of balance; and/or instruct in equipment to limit weight-bearing for the protection of a healing injury or surgery.

(i). Time to Produce Effect: Two to six treatments.

(ii). Frequency: Two to three times per week.

(iii). Optimum Duration: Two weeks.

(iv). Maximum Duration: Two weeks.

(f). Neuromuscular Re-education: is the skilled application of exercise with manual, mechanical, or electrical facilitation to enhance strength; movement patterns; neuromuscular response; proprioception; kinesthetic sense; coordination; education of movement, balance and posture. Indications include the need to promote neuromuscular responses through carefully timed proprioceptive stimuli to elicit and improve motor activity in patterns similar to normal neurologically developed sequences, and improve neuromotor response with independent control.

(i). Time to Produce Effect: Two to six treatments.

(ii). Frequency: Three times per week.

(iii). Optimum Duration: Four to eight weeks.

(iv). Maximum Duration: Eight weeks.

(g). Therapeutic Exercise is a generally accepted treatment with or without mechanical assistance or resistance, may include isoinertial, isotonic, isometric and isokinetic types of exercises. There is good evidence to support the functional benefits of manual therapy with exercise, walking programs, conditioning, and other combined therapy programs. Indications include the need for cardiovascular fitness, reduced edema, improved muscle strength, improved connective tissue strength and integrity, increased bone density, promotion of circulation to enhance soft tissue healing, improvement of muscle recruitment, increased range of motion and are used to promote normal movement patterns. May also include complementary/alternative exercise movement therapy.

(i). Time to Produce Effect: Two to six treatments.

(ii). Frequency: Three to five times per week.

(iii). Optimum Duration: Four to eight weeks.

(iv). Maximum Duration: Eight weeks.

(h). Wheelchair Management and Propulsion is the instruction and training of self-propulsion and proper use of a wheelchair. This includes transferring and safety instruction. This is indicated in individuals who are not able to ambulate due to bilateral lower extremity injuries, inability to use ambulatory assistive devices, and in cases of multiple traumas.

(i). Time to Produce Effect: Two to six treatments.

(ii). Frequency: Two to three times per week.

(iii). Optimum Duration: Two weeks.

(iv). Maximum Duration: Two weeks.

15. Therapy-passive. Most of the following passive therapies and modalities are generally well-accepted methods of care for a variety of work-related injuries. Passive therapy includes those treatment modalities that do not require energy expenditure on the part of the patient. They are principally effective during the early phases of treatment and are directed at controlling symptoms such as pain, inflammation and swelling and to improve the rate of healing soft tissue injuries. They should be use adjunctively with active therapies to help control swelling, pain, and inflammation during the rehabilitation process. They may be used intermittently as a therapist deems appropriate or regularly if there are specific goals with objectively measured functional improvements during treatment.

a. On occasion, specific diagnoses and post-surgical conditions may warrant durations of treatment beyond those listed as "maximum." Factors such as exacerbation of symptoms, re-injury, interrupted continuity of care and comorbidities may also extend durations of care. Specific goals with objectively measured functional improvement during treatment must be cited to justify extended durations of care. It is recommended that, if no functional gain is observed after the number of treatments under "time to

produce effect” has been completed alternative treatment interventions, further diagnostic studies, or further consultations should be pursued.

i. The following passive therapies and modalities are listed in alphabetical order.

(a). Continuous Passive Motion (CPM) is a form of passive motion using specialized machinery that acts to move a joint and may also pump blood and edema fluid away from the joint and periarticular tissues. CPM is effective in preventing the development of joint stiffness if applied immediately following surgery. It should be continued until the swelling that limits motion of the joint no longer develops. ROM for the joint begins at the level of patient tolerance and is increased twice a day as tolerated. Home use of CPM is expected after chondral defect surgery. CPM may be necessary for cases with ACL repair, manipulation, joint replacement or other knee surgery if the patient has been non compliant with pre-operative ROM exercises. Use of this equipment may require home visits.

- (i). Time to Produce Effect: Immediate.
- (ii). Frequency: Up to four times a day.
- (iii). Optimum Duration: Up to three weeks post surgical.
- (iv). Maximum Duration: Three weeks.

(b). Contrast Baths can be used for alternating immersion of extremities in hot and cold water. Indications include edema in the sub-acute stage of healing, the need to improve peripheral circulation and decrease joint pain and stiffness.

- (i). Time to Produce Effect: Three treatments.
- (ii). Frequency: Three times per week.
- (iii). Optimum Duration: Four weeks.
- (iv). Maximum Duration: One month.

(c). Electrical Stimulation (Unattended): once applied, requires minimal on-site supervision by the physician or non-physician provider. Indications include pain, inflammation, muscle spasm, atrophy, decreased circulation, and the need for osteogenic stimulation.

- (i). Time to Produce Effect: Two to four treatments.
- (ii). Frequency: Varies, depending upon indication, between two to three times per day to one time a week. Provide home unit if treatment is effective and frequent use is recommended.
- (iii). Optimum Duration: One to three months.
- (iv). Maximum Duration: Three months.

(d). Fluidotherapy: employs a stream of dry, heated air that passes over the injured body part. The injured body part can be exercised during the application of dry heat. Indications include the need to enhance collagen

extensibility before stretching, reduce muscle guarding, or reduce inflammatory response.

- (i). Time to Produce Effect: One to four treatments.
- (ii). Frequency: One to three times per week.
- (iii). Optimum Duration: Four weeks.
- (iv). Maximum Duration: One month.

(e). Hyperbaric Oxygen Therapy. There is no evidence to support long-term benefit of hyperbaric oxygen therapy for non-union lower extremity fractures. It is not recommended.

(f). Infrared Therapy is a radiant form of heat application. Indications include the need to elevate the pain threshold before exercise and to alleviate muscle spasm to promote increased movement.

- (i). Time to Produce Effect: Two to four treatments.
- (ii). Frequency: Three to five times per week.
- (iii). Optimum Duration: Three weeks as primary, or up to two months if used intermittently as an adjunct to other therapeutic procedures.
- (iv). Maximum Duration: Two months.

(g). Iontophoresis: is the transfer of medication, including, but not limited to, steroidal anti-inflammatory and anesthetics, through the use of electrical stimulation. Indications include pain (Lidocaine), inflammation (hydrocortisone, salicylate), edema (mecholy, hyaluronidase, and salicylate), ischemia (magnesium, mecholy, and iodine), muscle spasm (magnesium, calcium); calcific deposits (acetate), scars, and keloids (chlorine, iodine, acetate).

- (i). Time to Produce Effect: One to four treatments.
- (ii). Frequency: 3 times per week with at least 48 hours between treatments.
- (iii). Optimum Duration: 8 to 10 treatments.
- (iv). Maximum Duration: 10 treatments.

(h). Manipulation: is a generally accepted, well-established and widely used therapeutic intervention for lower extremity injuries. Manipulative treatment (not therapy) is defined as the therapeutic application of manually guided forces by an operator to improve physiologic function and/or support homeostasis that has been altered by the injury or occupational disease, and has associated clinical significance.

(i). High velocity, low amplitude (HVLA) technique, chiropractic manipulation, osteopathic manipulation, muscle energy techniques, counter strain, and non-force techniques are all types of manipulative treatment. This may be applied by osteopathic physicians (D.O.), chiropractors (D.C.), properly trained physical therapists



(P.T.), properly trained occupational therapists (O.T.), or properly trained medical physicians. Under these different types of manipulation exist many subsets of different techniques that can be described as a) direct a forceful engagement of a restrictive/pathologic barrier, b) indirect a gentle/non-forceful disengagement of a restrictive/pathologic barrier, c) the patient actively assists in the treatment and d) the patient relaxing, allowing the practitioner to move the body tissues. When the proper diagnosis is made and coupled with the appropriate technique, manipulation has no contraindications and can be applied to all tissues of the body. Pre-treatment assessment should be performed as part of each manipulative treatment visit to ensure that the correct diagnosis and correct treatment is employed.

[a]. Time to Produce Effect (for all types of manipulative treatment): One to six treatments.

[b]. Frequency: Up to three times per week for the first three weeks as indicated by the severity of involvement and the desired effect.

[c]. Optimum Duration: 10 treatments.

[d]. Maximum Duration: 12 treatments. Additional visits may be necessary in cases of re-injury, interrupted continuity of care, exacerbation of symptoms, and in those patients with co-morbidities. Functional gains including increased ROM must be demonstrated to justify continuing treatment.

(i). Manual Electrical Stimulation is used for peripheral nerve injuries or pain reduction that requires continuous application, supervision, or involves extensive teaching. Indications include muscle spasm (including TENS), atrophy, decreased circulation, osteogenic stimulation, inflammation, and the need to facilitate muscle hypertrophy, muscle strengthening, muscle responsiveness in Spinal Cord Injury/Brain Injury (SCI/BI), and peripheral neuropathies.

(i). Time to Produce Effect: Variable, depending upon use.

(ii). Frequency: Three to seven times per week.

(iii). Optimum Duration: Eight weeks.

(iv). Maximum Duration: Two months.

(j). Massage. Manual or Mechanical: Massage is manipulation of soft tissue with broad ranging relaxation and circulatory benefits. This may include stimulation of acupuncture points and acupuncture channels (acupressure), application of suction cups and techniques that include pressing, lifting, rubbing, pinching of soft tissues by, or with, the practitioners' hands. Indications include edema (peripheral or hard and non-pliable edema), muscle spasm, adhesions, the need to improve peripheral circulation and range of motion, or to increase muscle relaxation, and flexibility prior to exercise. In cases with edema, deep vein thrombosis should be ruled out prior to treatment.

(i). Time to Produce Effect: Immediate.

(ii). Frequency: One to two times per week.

(iii). Optimum Duration: Six weeks.

(iv). Maximum Duration: Two months.

(k). Mobilization (Joint). Mobilization is passive movement, which may include passive range of motion performed in such a manner (particularly in relation to the speed of the movement) that it is, at all times, within the ability of the patient to prevent the movement if they so choose. It may include skilled manual joint tissue stretching. Indications include the need to improve joint play, improve intracapsular arthrokinematics, or reduce pain associated with tissue impingement.

(i). Time to Produce Effect: Six to nine treatments.

(ii). Frequency: three times per week.

(iii). Optimum Duration: Six weeks.

(iv). Maximum Duration: Two months.

(l). Mobilization (Soft Tissue) is a generally well-accepted treatment. Mobilization of soft tissue is the skilled application of muscle energy, strain/counter strain, myofascial release, manual trigger point release and manual therapy techniques designed to improve or normalize movement patterns through the reduction of soft tissue pain and restrictions. These can be interactive with the patient participating or can be with the patient relaxing and letting the practitioner move the body tissues. Indications include muscle spasm around a joint, trigger points, adhesions, and neural compression. Mobilization should be accompanied by active therapy.

(i). Time to Produce Effect: Two to three weeks.

(ii). Frequency: Two to three times per week.

(iii). Optimum Duration: Four to six weeks.

(iv). Maximum Duration: Six weeks.

(m). Paraffin Bath is a superficial heating modality that uses melted paraffin (candle wax) to treat irregular surfaces such as the foot or ankle. Indications include the need to enhance collagen extensibility before stretching, reduce muscle guarding, or reduce inflammatory response.

(i). Time to Produce Effect: One to four treatments.

(ii). Frequency: One to three times per week.

(iii). Optimum Duration: Four weeks.

(iv). Maximum Duration: One month. If beneficial, provide with home unit or purchase if effective.

(n). Superficial Heat and Cold Therapy: Superficial heat and cold therapies are thermal agents applied in various manners that lower or raise the body tissue temperature for the reduction of pain, inflammation, and/or effusion resulting from injury or induced by exercise.

It may be used acutely with compression and elevation. Indications include acute pain, edema and hemorrhage, need to increase pain threshold, reduce muscle spasm and promote stretching/flexibility. It includes portable cryotherapy units and application of heat just above the surface of the skin at acupuncture points.

(i). Time to Produce Effect: Immediate.

(ii). Frequency: Two to five times per week.

(iii). Optimum Duration: Three weeks as primary, or up to two months if used intermittently as an adjunct to other therapeutic procedures.

(iv). Maximum Duration: Two months.

(o). Short-Wave Diathermy involves the use of equipment that exposes soft tissue to a magnetic or electrical field. Indications include enhanced collagen extensibility before stretching, reduced muscle guarding, reduced inflammatory response, and enhanced re-absorption of hemorrhage, hematoma, or edema.

(i). Time to Produce Effect: Two to four treatments.

(ii). Frequency: Two to three times per week up to three weeks.

(iii). Optimum Duration: Three to five weeks.

(iv). Maximum Duration: 5 weeks.

(p). Traction. Manual traction is an integral part of manual manipulation or joint mobilization. Indications include decreased joint space, muscle spasm around joints, and the need for increased synovial nutrition and response.

(i). Time to Produce Effect: One to three sessions.

(ii). Frequency: Two to three times per week.

(iii). Optimum Duration: 30 days.

(iv). Maximum Duration: One month.

(q). Transcutaneous Electrical Nerve Stimulation (TENS) is a generally accepted treatment. TENS should include at least one instructional session for proper application and use. Indications include muscle spasm, atrophy, and decreased circulation and pain control. Minimal TENS unit parameters should include pulse rate, pulse width and amplitude modulation. Consistent, measurable functional improvement must be documented prior to the purchase of a home unit.

(i). Time to Produce Effect: Immediate.

(ii). Frequency: Variable.

(iii). Optimum Duration: Three sessions.

(iv). Maximum Duration: Three sessions. If beneficial, provide with home unit or purchase if effective. Due to variations in costs and in models, prior authorization for home units is required.

(r). Ultrasound is an accepted treatment which includes ultrasound with electrical stimulation and Phonophoresis. Ultrasound uses sonic generators to deliver acoustic energy for therapeutic thermal and/or non-thermal soft tissue effects. Indications include scar tissue, adhesions, collagen fiber and muscle spasm, and the need to extend muscle tissue or accelerate the soft tissue healing.

(i). Ultrasound with electrical stimulation is concurrent delivery of electrical energy that involves a dispersive electrode placement. Indications include muscle spasm, scar tissue, pain modulation, and muscle facilitation.

(ii). Phonophoresis is the transfer of medication to the target tissue to control inflammation and pain through the use of sonic generators. These topical medications include, but are not limited to, steroidal anti-inflammatory and anesthetics.

[a]. Time to Produce Effect: 6 to 15 treatments.

[b]. Frequency: Three times per week.

[c]. Optimum Duration: Four to eight weeks.

[d]. Maximum Duration: Two months.

(s). Vasopneumatic Devices are mechanical compressive devices used in both inpatient and outpatient settings to reduce various types of edema. Indications include pitting edema, lymphedema and venostasis. Maximum compression should not exceed minimal diastolic blood pressure. Use of a unit at home should be considered if expected treatment is greater than two weeks.

(i). Time to Produce Effect: One to three treatments.

(ii). Frequency: Three to five times per week.

(iii). Optimum Duration: One month.

(iv). Maximum Duration: One month. If beneficial, provide with home unit.

(t). Whirlpool/Hubbard tank is conductive exposure to water at temperatures that best elicits the desired effect (cold vs. heat). It generally includes massage by water propelled by a turbine or Jacuzzi jet system and has the same thermal effects as hot packs if higher than tissue temperature. It has the same thermal effects as cold application if comparable temperature water used. Indications include the need for analgesia, relaxing muscle spasm, reducing joint stiffness, enhancing mechanical debridement and facilitating and preparing for exercise.

(i). Time to Produce Effect: Two to four treatments.

(ii). Frequency: Three to five times per week.

(iii). Optimum Duration: Three weeks as primary, or up to two months if used intermittently as an adjunct to other therapeutic procedures.

(iv). Maximum Duration: Two months.

16. Vocational rehabilitation is a generally accepted intervention. Initiation of vocational rehabilitation requires adequate evaluation of patients for quantification of highest functional level, motivation and achievement of maximum medical improvement (MMI). Vocational rehabilitation may be as simple as returning to the original job or as complicated as being retrained for a new occupation. The effectiveness of vocational rehabilitation may be enhanced when performed in combination with work hardening or work conditioning.

a. It may also be beneficial for full vocational rehabilitation to be started before MMI if it is evident that the injured worker will be unable to return to his/her previous occupation. A positive goal and direction may aid the patient in decreasing stress and depression, and promote optimum rehabilitation.

AUTHORITY NOTE: Promulgated in accordance with R.S. 23:1203.1.

HISTORICAL NOTE: Promulgated by the Louisiana Workforce Commission, Office of Workers Compensation Administration, LR 37:1801 (June 2011).

### **§2313. Therapeutic Procedures—Operative**

A. All operative interventions must be based upon positive correlation of clinical findings, clinical course and diagnostic tests. A comprehensive assimilation of these factors must lead to a specific diagnosis with positive identification of pathologic condition(s). It is imperative to rule out non-physiologic modifiers of pain presentation or non-operative conditions mimicking radiculopathy or instability (e.g., peripheral neuropathy, piriformis syndrome, myofascial pain, complex regional pain syndrome or sympathetically mediated pain syndromes, sacroiliac dysfunction, psychological conditions, etc.) prior to consideration of elective surgical intervention.

B. In addition, operative treatment is indicated when the natural history of surgically treated lesions is better than the natural history for non-operatively treated lesions. All patients being considered for surgical intervention should first undergo a comprehensive neuromusculoskeletal examination to identify mechanical pain generators that may respond to non-surgical techniques or may be refractory to surgical intervention.

C. Structured rehabilitation interventions are necessary for all of the following procedures except in some cases of hardware removal.

D. Return-to-work restrictions should be specific according to the recommendation in the Therapeutic Procedures, Non-Operative.

#### **1. Ankle and Subtalar Fusion**

a. Description/Definition: Surgical fusion of the ankle or subtalar joint.

b. Occupational Relationship: Usually post-traumatic arthritis or residual deformity.

c. Specific Physical Exam Findings: Painful, limited range of motion of the joint(s). Possible fixed deformity.

d. Diagnostic Testing Procedures: Radiographs. Diagnostic injections, MRI, CT scan, and/or bone scan.

e. Surgical Indications/Considerations: All reasonable conservative measures have been exhausted and other reasonable surgical options have been seriously considered or implemented. Patient has disabling pain or deformity. Fusion is the procedure of choice for individuals with osteoarthritis who plan to return to physically demanding activities.

i. Prior to surgical intervention, the patient and treating physician should identify functional operative goals, and the likelihood of achieving improved ability to perform activities of daily living or work activities and the patient should agree to comply with the pre- and post-operative treatment plan including home exercise. The provider should be especially careful to make sure the patient understands the amount of post-operative therapy required and the length of partial- and full-disability expected post-operatively.

ii. Because smokers have a higher risk of delayed bone healing and post-operative costs, it is recommended that insurers cover a smoking cessation program peri-operatively. Physicians may monitor smoking cessation with laboratory tests such as cotinine levels for long-term cessation.

f. Operative Procedures. Open reduction internal fixation (ORIF) with possible bone grafting. External fixation may be used in some cases.

#### **g. Post-Operative Treatment**

i. An individualized rehabilitation program based upon communication between the surgeon and the therapist and using therapies as outlined in Therapeutic Procedures, Non-operative. In all cases, communication between the physician and therapist is important to the timing of weight-bearing, and exercise progressions.

ii. When boney union is achieved, treatment usually includes active therapy with or without passive therapy, including gait training and ADLs.

iii. Rocker bottom soles or shoe lifts may be required. A cast is usually in place for six to eight weeks followed by graduated weight-bearing. Modified duty may last up to four to six months.

iv. Return to work and restrictions after surgery may be made by an attending physician experienced in occupational medicine in consultation with the surgeon or by the surgeon.

#### **2. Knee Fusion**

a. Description/Definition: Surgical fusion of femur to the tibia at the knee joint.

b. Occupational Relationship: Usually from post-traumatic arthritis or deformity.

c. Specific Physical Exam Findings: Stiff, painful, sometime deformed limb at the knee joint.

d. Diagnostic Testing Procedures: Radiographs, MRI, CT, diagnostic injections or bone scan.

e. Surgical Indications/Considerations: All reasonable conservative measures have been exhausted and other reasonable surgical options have been seriously considered or implemented, e.g. failure of arthroplasty. Fusion is a consideration particularly in the young patient who desires a lifestyle that would subject the knee to high mechanical stresses. The patient should understand that the leg will be shortened and there may be difficulty with sitting in confined spaces, and climbing stairs. Although there is generally a painless knee, up to 50 percent of cases may have complications.

i. Prior to surgical intervention, the patient and treating physician should identify functional operative goals and the likelihood of achieving improved ability to perform activities of daily living or work activities and the patient should agree to comply with the pre- and post-operative treatment plan including home exercise. The provider should be especially careful to make sure the patient understands the amount of post-operative therapy required and the length of partial- and full-disability expected post-operatively.

ii. Because smokers have a higher risk of delayed bone healing and post-operative costs, it is recommended that insurers cover a smoking cessation program peri-operatively. Physicians may monitor smoking cessation with laboratory tests such as cotinine levels for long-term cessation.

f. Operative Procedures. Open reduction internal fixation (ORIF) with possible bone grafting. External fixation or intramedullary rodding may also be used.

#### g. Post-Operative Treatment

i. An individualized rehabilitation program based upon communication between the surgeon and the therapist and using therapies as outlined in Therapeutic Procedures, Non-operative. In all cases, communication between the physician and therapist is important to the timing of weight-bearing, and exercise progressions.

ii. When boney union is achieved, treatment usually includes active therapy with or without passive therapy, including gait training and ADLs. Non weight-bearing or limited weight-bearing and modified duty may last up to four and six months.

iii. Return to work and restrictions after surgery may be made by an attending physician experienced in occupational medicine in consultation with the surgeon or by the surgeon.

### 3. Ankle Arthroplasty

a. Description/Definition: Prosthetic replacement of the articulating surfaces of the ankle joint.

b. Occupational Relationship: Usually from post-traumatic arthritis.

c. Specific Physical Exam Findings: Stiff, painful ankle. Limited range-of-motion of the ankle joint.

d. Diagnostic Testing Procedures: Radiographs, MRI, diagnostic injections, CT scan, bone scan.

e. Surgical Indications/Considerations: When pain interferes with ADLs, and all reasonable conservative measures have been exhausted and other reasonable surgical options have been considered or implemented. A very limited population of patients are appropriate for ankle arthroplasty.

#### i. Requirements include:

(a). Good bone quality;

(b). BMI less than 35;

(c). Non-smoker currently;

(d). Patient is 60 or older;

(e). No lower extremity neuropathy;

(f). Patient does not pursue physically demanding work or recreational activities.

ii. The following issues should be addressed when determining appropriateness for surgery: ankle laxity, bone alignment, surrounding soft tissue quality, vascular status, presence of avascular necrosis, history of open fracture or infection, motor dysfunction, and treatment of significant knee or hip pathology.

iii. Ankle implants are less successful than similar procedures in the knee or hip. There are no good studies comparing arthrodesis and ankle replacement. Patients with ankle fusions generally have good return to function and fewer complications than those with joint replacements. Re-operation rates may be higher in ankle arthroplasty than in ankle arthrodesis. Long-term performance beyond ten years for current devices is still unclear. Salvage procedures for ankle replacement include revision with stemmed implant or allograft fusion. Given these factors, an ankle arthroplasty requires prior authorization and a second opinion by a surgeon specializing in lower extremity surgery.

iv. Contraindications—severe osteoporosis, significant general disability due to other medical conditions, psychiatric issues.

v. In cases where surgery is contraindicated due to obesity, it may be appropriate to recommend a weight loss program if the patient is unsuccessful losing weight on their own. Coverage for weight loss would continue only for motivated patients who have demonstrated continual progress with weight loss.

vi. Prior to surgery, patients may be assessed for any associated mental health or low back pain issues that may affect rehabilitation.

vii. Prior to surgical intervention, the patient and treating physician should identify functional operative goals and the likelihood of achieving improved ability to perform activities of daily living or work activities and the patient

should agree to comply with the pre- and post-operative treatment plan including home exercise. The provider should be especially careful to make sure the patient understands the amount of post-operative therapy required and the length of partial- and full-disability expected post-operatively.

viii. Because smokers have a higher risk of delayed bone healing and post-operative costs, it is recommended that insurers cover a smoking cessation program peri-operatively. Physicians may monitor smoking cessation with laboratory tests such as cotinine levels for long-term cessation.

f. Operative Procedures: Prosthetic replacement of the articular surfaces of the ankle; DVT prophylaxis is not always required but should be considered for patients who have any risk factors for thrombosis.

i. Complications include pulmonary embolism, infection, bony lysis, polyethylene wear, tibial loosening, instability, malalignment, stiffness, nerve-vessel injury, and peri-prosthetic fracture.

g. Post-Operative Treatment

i. An individualized rehabilitation program based upon communication between the surgeon and the therapist while using therapies as outlined in Therapeutic Procedures, Non-operative. In all cases, communication between the physician and therapist is important to the timing of weight-bearing, and exercise progressions.

ii. NSAIDs may be used for pain management after joint replacement. They have also been used to reduce heterotopic ossification after ankle arthroplasty. NSAIDs do reduce the radiographically documented heterotopic ossification in this setting, but there is some evidence (in literature on hip arthroplasty) that they do not improve functional outcomes and they may increase the risk of bleeding events in the post-operative period. Their routine use for prevention of heterotopic bone formation is not recommended.

iii. Treatment may include the following: bracing, active therapy with or without passive therapy, gait training, and ADLs. Rehabilitation post-operatively may need to be specifically focused based on the following problems: contracture, gastrocnemius muscle weakness, and foot and ankle malalignment. Thus, therapies may include braces, shoe lifts, orthoses, and electrical stimulation accompanied by focused therapy.

iv. In some cases aquatic therapy may be used. Refer to Therapeutic Procedures, Non-operative Aquatic Therapy. Pool exercises may be done initially under therapist's or surgeon's direction then progressed to an independent pool program.

v. Prior to revision surgery there should be an evaluation to rule out infection.

vi. Return to work and restrictions after surgery may be made by a treating physician experienced in occupational medicine in consultation with the surgeon or by the surgeon. Patient should be able to return to sedentary

work within four to six weeks. Some patients may have permanent restrictions based on their job duties.

vii. Patients are usually seen annually after initial recovery to check plain x-rays for signs of loosening.

4. Knee Arthroplasty

a. Description/Definition: Prosthetic replacement of the articulating surfaces of the knee joint with or without robotic assistance.

b. Occupational Relationship: Usually from post-traumatic osteoarthritis.

c. Specific Physical Exam Findings: Stiff, painful knee, and possible effusion.

d. Diagnostic Testing Procedures: Radiographs.

e. Surgical Indications/Considerations: Severe osteoarthritis and all reasonable conservative measures have been exhausted and other reasonable surgical options have been considered or implemented. Significant changes such as advanced joint line narrowing are expected. Refer to subsection Aggravated Osteoarthritis.

i. Younger patients, less than 50 years of age, may be considered for unicompartmental replacement if there is little or no arthritis in the lateral compartment, there is no inflammatory disease and/or deformity and BMI is less than 35. They may be considered for lateral unicompartmental disease when the patient is not a candidate for osteotomy. Outcome is better for patients with social support.

ii. Contraindications—severe osteoporosis, significant general disability due to other medical conditions, psychiatric issues.

iii. In cases where surgery is contraindicated due to obesity, it may be appropriate to recommend a weight loss program if the patient is unsuccessful losing weight on their own. Coverage for weight loss would continue only for motivated patients who have demonstrated continual progress with weight loss. Furthermore several studies suggest that morbid obesity (BMI > or = to 40) is associated with lower implant survivorship, lower functional outcome, and a higher rate of complications in TKA patients. Patients with BMI greater than 40 require a second expert surgical opinion.

iv. Prior to surgery, patients may be assessed for any associated mental health or low back pain issues that may affect rehabilitation.

v. Prior to surgical intervention, the patient and treating physician should identify functional operative goals and the likelihood of achieving improved ability to perform activities of daily living or work activities and the patient should agree to comply with the pre- and post-operative treatment plan including home exercise. The provider should be especially careful to make sure the patient understands the amount of post-operative therapy required and the length of partial- and full-disability expected post-operatively.

vi. Because smokers have a higher risk of delayed bone healing and post-operative costs, it is recommended that insurers cover a smoking cessation program peri-operatively. Physicians may monitor smoking cessation with laboratory tests such as cotinine levels for long-term cessation.

f. Operative Procedures: Prosthetic replacement of the articular surfaces of the knee; total or uni-compartmental with DVT prophylaxis. May include patellar resurfacing and computer assistance.

i. There is currently conflicting evidence on the effectiveness of patellar resurfacing. Isolated patellofemoral resurfacing is performed on patients under 60 only after diagnostic arthroscopy does not reveal any arthritic changes in other compartments. The diagnostic arthroscopy is generally performed at the same time as the resurfacing. Resurfacing may accompany a total knee replacement at the discretion of the surgeon.

ii. Computer guided implants are more likely to be correctly aligned. The overall long-term functional result using computer guidance is unclear. Decisions to use computer assisted methods depend on surgeon preference and age of the patient as it is more likely to have an impact on younger patients with longer expected use and wear of the implant. Alignment is only one of many factors that may affect the implant longevity.

iii. Complications occur in around 3 percent and include pulmonary embolism; infection, bony lysis, polyethylene wear, tibial loosening, instability, malalignment, stiffness, patellar tracking abnormality, nerve-vessel injury, and peri-prosthetic fracture.

g. Post-Operative Treatment:

i. Anti coagulant therapy to prevent deep vein thrombosis. Refer to Therapeutic Procedures, Non-operative.

ii. NSAIDs may be used for pain management after joint replacement. They have also been used to reduce heterotopic ossification after knee arthroplasty. NSAIDs do reduce the radiographically documented heterotopic ossification in this setting, but there is some evidence (in literature on total hip arthroplasty) that they do not improve functional outcomes and they may increase the risk of bleeding events in the post-operative period. Their routine use for prevention of heterotopic bone formation is not recommended.

iii. An individualized rehabilitation program based upon communication between the surgeon and the therapist and using therapies as outlined in Therapeutic Procedures, Non-operative. In all cases, communication between the physician and therapist is important to the timing of weight-bearing, and exercise progressions.

iv. Treatment may include the following: bracing and active therapy with or without passive therapy. Rehabilitation post-operatively may need to be specifically focused based on the following problems: knee flexion contracture, quadriceps muscle weakness, knee flexion

deficit, and foot, and ankle malalignment. Thus, therapies may include, knee braces, shoe lifts, orthoses, and electrical stimulation, accompanied by focused active therapy.

v. In some cases aquatic therapy may be used. Refer to Therapeutic Procedures, Non-operative, Aquatic Therapy. Pool exercises may be done initially under therapist's or surgeon's direction then progressed to an independent pool program.

vi. Continuous passive motion is frequently prescribed. The length of time it is used will depend on the patient and their ability to return to progressive exercise.

vii. Consider need for manipulation under anesthesia if there is less than 90 degrees of knee flexion after six weeks.

viii. Prior to revision surgery there should be an evaluation to rule out infection.

ix. Return to work and restrictions after surgery may be made by an attending physician experienced in occupational medicine in consultation with the surgeon or by the surgeon. Patient should be able to return to sedentary work within four to six weeks. Some patients may have permanent restrictions based on their job duties.

x. Patients are usually seen annually after initial recovery to check plain x-rays for signs of loosening.

## 5. Hip Arthroplasty

a. Description/Definition: Prosthetic replacement of the articulating surfaces of the hip joint. In some cases, hip resurfacing may be performed.

b. Occupational Relationship: Usually from post-traumatic arthritis, hip dislocations and femur or acetabular fractures. Patients with intracapsular femoral fractures have a risk of developing avascular necrosis of the femoral head requiring treatment months to years after the initial injury.

c. Specific Physical Exam Findings: Stiff, painful hip.

d. Diagnostic Testing Procedures: Standing pelvic radiographs demonstrating joint space narrowing to 2 mm or less, osteophytes or sclerosis at the joint. MRI may be ordered to rule out other more serious disease.

e. Surgical Indications/Considerations: Severe osteoarthritis and all reasonable conservative measures have been exhausted and other reasonable surgical options have been considered or implemented. Refer to subsection Aggravated Osteoarthritis.

i. Possible contraindications - inadequate bone density, prior hip surgery, and obesity.

ii. In cases where surgery is contraindicated due to obesity, it may be appropriate to recommend a weight loss program if the patient is unsuccessful losing weight on their own. Coverage for weight loss would continue only for motivated patients who have demonstrated continual progress with weight loss.

iii. Prior to surgery, patients may be assessed for any associated mental health or low back pain issues that may affect rehabilitation.

iv. For patients undergoing total hip arthroplasty, there is some evidence that a pre-operative exercise conditioning program, including aquatic and land-based exercise, results in quicker discharge to home than pre-operative education alone without an exercise program.

v. Aseptic loosening of the joint requiring revision surgery occurs in some patients. Prior to revision the joint should be checked to rule out possible infection which may require a bone scan as well as laboratory procedures, including a radiologically directed joint aspiration.

vi. Because smokers have a higher risk of non-union and post-operative costs, it is recommended that carriers cover a smoking cessation program peri-operatively. Physicians may monitor smoking cessation with laboratory tests such as cotinine levels for long-term cessation.

f. Operative Procedures: Prosthetic replacement of the articular surfaces of the hip, ceramic or metal prosthesis, with DVT prophylaxis. Ceramic prosthesis is more expensive; however, it is expected to have greater longevity and may be appropriate in some younger patients. Hip resurfacing, metal on metal, is an option for younger or active patients likely to out-live traditional total hip replacements.

i. Complications include, leg length inequality, deep venous thrombosis with possible pulmonary embolus, hip dislocation, possible renal effects, need for transfusions, future infection, need for revisions, fracture at implant site.

ii. The long-term benefit for computer assisted hip replacements is unknown. It may be useful in younger patients. Prior authorization is required.

iii. Robotic assisted surgery is considered experimental and not recommended due to technical difficulties.

#### g. Post-Operative Treatment

i. Anti coagulant therapy is used to prevent deep vein thrombosis. Refer to Therapeutic Procedures, Non-operative.

ii. NSAIDs may be used for pain management after joint replacement. They have also been used to reduce heterotopic ossification after hip arthroplasty. NSAIDs do reduce the radiographically documented heterotopic ossification in this setting, but there is some evidence that they do not improve functional outcomes and they may increase the risk of bleeding events in the post-operative period. Their routine use for prevention of heterotopic bone formation is not recommended.

iii. An individualized rehabilitation program based upon communication between the surgeon and the therapist and using the therapies as outlined in Therapeutic Procedures Non-operative. In all cases, communication

between the physician and therapist is important to the timing of weight-bearing and exercise progressions.

iv. Treatment usually includes active therapy with or without passive therapy with emphasis on gait training with appropriate assistive devices. Patients with accelerated return to therapy appear to do better. Therapy should include training on the use of adaptive equipment and home and work site evaluation when appropriate.

(a). There is good evidence for the use of aquatic therapy. Refer to Therapeutic Procedures, Non-operative. Pool exercises may be done initially under a therapist's or surgeon's direction then progressed to an independent pool program.

(b). There is some evidence that, for patients older than 60, early multidisciplinary therapy may shorten hospital stay and improve activity level for those receiving hip replacement. Therefore, this may be used for selected patients.

v. Return to activities at four to six weeks with appropriate restrictions by the surgeon. Initially range of motion is usually restricted. Return to activity after full recovery depends on the surgical approach. Patients can usually lift, but jogging and other high impact activities are avoided.

vi. Helical CT or MRI with artifact minimization may be used to investigate prosthetic complications. The need for implant revision is determined by age, size of osteolytic lesion, type of lesion and functional status. Revision surgery may be performed by an orthopedic surgeon in cases with chronic pain and stiffness or difficulty with activities of daily living. Prior authorization is required and a second opinion by a surgeon with special expertise in hip/knee replacement surgery should usually be performed.

vii. Return to work and restrictions after surgery may be made by an attending physician experienced in occupational medicine in consultation with the surgeon or by the surgeon.

viii. Patients are usually seen annually after the initial recovery to check plain x-rays for signs of loosening.

#### 6. Amputation

a. Description/Definition: Surgical removal of a portion of the lower extremity.

b. Occupational Relationship: Usually secondary to post-traumatic bone, soft tissue, vascular or neurologic compromise of part of the extremity.

c. Specific Physical Exam Findings: Non-useful or non-viable portion of the lower extremity.

d. Diagnostic Testing Procedures: Radiographs, vascular studies, MRI, bone scan.

e. Surgical Indications/Considerations: Non-useful or non-viable portion of the extremity.

i. Smoking may affect soft tissue healing through tissue hypoxia. Patients should be strongly encouraged to

stop smoking and be provided with appropriate counseling by the physician.

f. Operative Procedures: Amputation.

g. Post-Operative Treatment

i. An individualized rehabilitation program based upon communication between the surgeon and the therapist and using therapies as outlined in Therapeutic Procedures, Non-operative.

ii. Rigid removable dressings are used initially.

iii. Therapies usually include active therapy with or without passive therapy for prosthetic fitting, construction and training, protected weight-bearing, training on the use of adaptive equipment, and home and jobsite evaluation. Temporary prosthetics are used initially with a final prosthesis fitted by the second year. Multiple fittings and trials may be necessary to assure the best functional result.

iv. For prosthesis with special adaptive devices, e.g. computerized prosthesis; prior authorization and a second opinion from a physician knowledgeable in prosthetic rehabilitation and who has a clear description of the patients expected job duties and daily living activities are required.

v. Return to work and restrictions after surgery may be made by an attending physician experienced in occupational medicine in consultation with the surgeon or by the surgeon.

#### 7. Manipulation under Anesthesia

a. Description/Definition: Passive range of motion of a joint under anesthesia.

b. Occupational Relationship: Joint stiffness that usually results from a traumatic injury, compensation related surgery, or other treatment.

c. Specific Physical Exam Findings: Joint stiffness in both active and passive modes.

d. Diagnostic Testing Procedures: Radiographs. CT, MRI, diagnostic injections.

e. Surgical Indications/Considerations: Consider if routine therapeutic modalities, including therapy and/or dynamic bracing, do not restore the degree of motion that should be expected after a reasonable period of time, usually at least 12 weeks.

f. Operative Treatment: Not applicable.

g. Post-Operative Treatment

i. An individualized rehabilitation program based upon communication between the surgeon and the therapist and using therapies as outlined in Therapeutic Procedures, Non-operative. Therapy includes a temporary increase in frequency of both active and passive therapy to maintain the range of motion gains from surgery;

ii. Continuous passive motion is frequently used post-operatively;

iii. Return to work and restrictions after surgery may be made by an attending physician experienced in occupational medicine in consultation with the surgeon or by the surgeon.

#### 8. Osteotomy

a. Description/Definition: A reconstructive procedure involving the surgical cutting of bone for realignment. It is useful for patients that would benefit from realignment in lieu of total joint replacement.

b. Occupational Relationship: Post-traumatic arthritis or deformity.

c. Specific Physical Exam Findings: Painful decreased range of motion and/or deformity.

d. Diagnostic Testing Procedures: Radiographs, MRI scan, CT scan.

e. Surgical Indications/Considerations: Failure of non-surgical treatment when avoidance of total joint arthroplasty is desirable. For the knee, joint femoral osteotomy may be desirable for young or middle age patients with varus alignment and medial arthritis or valgus alignment and lateral compartment arthritis. High tibial osteotomy is also used for medial compartment arthritis. Multi-compartmental degeneration is a contraindication. Patients should have a range of motion of at least 90 degrees of knee flexion. For the ankle supra malleolar osteotomy may be appropriate. High body mass is a relative contraindication.

i. Because smokers have a higher risk of non-union and post-operative costs, it is recommended that carriers cover a smoking cessation program peri-operatively. Physicians may monitor smoking cessation with laboratory tests such as cotinine levels for long-term cessation.

f. Operative Procedures: Peri-articular opening or closing wedge of bone, usually with grafting and internal or external fixation.

i. Complications: new fractures, lateral peroneal nerve palsy, infection, delayed unions, compartment syndrome, or pulmonary embolism.

g. Post-Operative Treatment

i. An individualized rehabilitation program based upon communication between the surgeon and the therapist and using therapies as outlined in Therapeutic Procedures, Non-operative. In all cases, communication between the physician and therapist is important to the timing of weight-bearing, and exercise progressions.

ii. Weight-bearing and range-of-motion exercises depend on the type of procedure performed. Partial or full weight-bearing restrictions can range from six weeks partial weight-bearing, to three months full weight-bearing. It is usually six months before return to sports or other rigorous physical activity.

iii. If femoral intertrochanteric osteotomy has been performed, there is some evidence that electrical bone



growth stimulation may improve bone density. Refer to Therapeutic Procedures, Non-operative, Bone Growth Stimulators for description.

iv. Return to work and restrictions after surgery may be made by an attending physician experienced in occupational medicine in consultation with the surgeon or by the surgeon.

9. Hardware Removal. Hardware removal frequently occurs after initial MMI. Physicians should document the possible need for hardware removal and include this as treatment in their final report.

a. Description/Definition: Surgical removal of internal or external fixation device, commonly related to fracture repairs.

b. Occupational Relationship: Usually following healing of a post-traumatic injury that required fixation or reconstruction using instrumentation.

c. Specific Physical Exam Findings: Local pain to palpation, swelling, erythema.

d. Diagnostic Testing Procedures: Radiographs, tomography, CT scan, MRI.

e. Surgical Indications/Considerations: Persistent local pain, irritation around hardware.

f. Operative Procedures: Removal of hardware may be accompanied by scar release/resection, and/or manipulation. Some instrumentation may be removed in the course of standard treatment without symptoms of local irritation.

g. Post-Operative Treatment

i. An individualized rehabilitation program based upon communication between the surgeon and the therapist and using therapies as outlined in Therapeutic Procedures, Non-operative.

ii. Treatment may include therapy with or without passive therapy for progressive weight-bearing, range of motion.

iii. Return to work and restrictions after surgery may be made by an attending physician experienced in occupational medicine in consultation with the surgeon or by the surgeon.

10. Release of Contracture

a. Description/Definition: Surgical incision or lengthening of contracted tendon or peri-articular soft tissue.

b. Occupational Relationship: Usually following a post-traumatic complication.

c. Specific Physical Exam Findings: Shortened tendon or stiff joint.

d. Diagnostic Testing Procedures: Radiographs, CT scan, MRI scan.

e. Surgical Indications/Considerations: Persistent shortening or stiffness associated with pain and/or altered function.

i. Smoking may affect soft tissue healing through tissue hypoxia. Patients should be strongly encouraged to stop smoking and be provided with appropriate counseling by the physician.

f. Operative Procedures: Surgical incision or lengthening of involved soft tissue.

g. Post-Operative Treatment:

i. An individualized rehabilitation program based upon communication between the surgeon and the therapist and using therapies as outlined in Therapeutic Procedures, Non-Operative.

ii. Treatments may include active therapy with or without passive therapy for stretching, range of motion exercises.

iii. Return to work and restrictions after surgery may be made by an attending physician experienced in occupational medicine in consultation with the surgeon or by the surgeon.

11. Human Bone Morphogenetic Protein (RhBMP)

a. (RhBMP) is a member of a family of proteins which are involved in the growth, remodeling, and regeneration of bone tissue. It has become available as a recombinant biomaterial with osteo-inductive potential for application in long bone fracture non-union and other situations in which the promotion of bone formation is desired. RhBMP may be used with intramedullary rod treatment for open tibial fractures an open tibial Type III A and B fracture treated with an intramedullary rod. There is some evidence that it decreases the need for further procedures when used within 14 days of the injury. It should not be used in those with allergies to the preparation, or in females with the possibility of child bearing, or those without adequate neurovascular status or those less than 18 years old. Ectopic ossification into adjacent muscle has been reported to restrict motion in periarticular fractures. Other than for tibial open fractures as described above, it should be used principally for non-union of fractures that have not healed with conventional surgical management or periprosthetic fractures. Due to the lack of information on the incidence of complications and overall success rate in these situations, its use requires prior authorization. Refer to Tibial Fracture.

AUTHORITY NOTE: Promulgated in accordance with R.S. 23:1203.1.

HISTORICAL NOTE: Promulgated by the Louisiana Workforce Commission, Office of Workers Compensation Administration, LR 37:1814 (June 2011), amended LR 48:516 (March 2022).

**Subchapter B. Shoulder Injury  
Medical Treatment Guidelines**

Editor's Note: Form LWC-WC 1009. Disputed Claim for Medical Treatment has been moved to §2328 of this Part.

**§2315. Introduction**

A. This document has been prepared by the Louisiana Workforce Commission, Office of Workers' Compensation and should be interpreted within the context of guidelines for physicians/providers treating individuals qualifying under Louisiana's Workers' Compensation Act as injured workers with shoulder injuries. Although the primary purpose of this document is advisory and educational, these guidelines are enforceable under the Louisiana Workers Compensation Act. All medical care, services, and treatment owed by the employer to the employee in accordance with the Louisiana Workers' Compensation Act shall mean care, services, and treatment in accordance with these guidelines. Medical Care, services, and treatment that varies from these guidelines shall also be due by the employer when it is demonstrated to the medical director of the office by a preponderance of the scientific medical evidence, that a variance from these guidelines is reasonably required to cure or relieve the injured worker from the effects of the injury or occupational disease given the circumstances. Therefore, these guidelines are not relevant as evidence of a provider's legal standard of professional care. To properly utilize this document, the reader should not skip nor overlook any sections.

AUTHORITY NOTE: Promulgated in accordance with R.S. 23:1203.1.

HISTORICAL NOTE: Promulgated by the Louisiana Workforce Commission, Office of Workers Compensation Administration, LR 37:1820 (June 2011), LR 49:520 (March 2023).

**§2317. General Guideline Principles**

A. The principles summarized in this section are key to the intended implementation of all Office of Workers' Compensation medical treatment guidelines and critical to the reader's application of the guidelines in this document.

1. Application of Guidelines. The OWCA provides procedures to implement medical treatment guidelines and to foster communication to resolve disputes among the provider, payer, and patient through the Workers' Compensation Act.

2. Education. Education of the patient and family, as well as the employer, insurer, policy makers and the community should be the primary emphasis in the treatment of workers' compensation injuries. Currently, practitioners often think of education last, after medications, manual therapy, and surgery. Practitioners must develop and implement strategies to educate patients, employers, insurance systems, policy makers, and the community as a whole. An education-based paradigm should always start with inexpensive communication providing reassuring and evidence-based information to the patient. More in-depth education is currently a component of treatment regimens which employ functional, restorative, preventive and rehabilitative programs. No treatment plan is complete without addressing issues of individual and/or group patient education as a means of facilitating self-management of symptoms and prevention. . Facilitation through language interpretation, when necessary, is a priority and part of the medical care treatment protocol.

3. Informed Decision Making. Providers should implement informed decision making as a crucial element of a successful treatment plan. Patients, with the assistance of their health care practitioner, should identify their personal and professional functional goals of treatment at the first visit. Progress towards the individual's identified functional goals should be addressed by all members of the health care team at subsequent visits and throughout the established treatment plan. Nurse case managers, physical therapists, and other members of the health care team play an integral role in informed decision-making and achievement of functional goals. Patient education and informed decision-making should facilitate self-management of symptoms and prevention of further injury.

4. Treatment Parameter Duration. Time frames for specific interventions commence once treatments have been initiated, not on the date of injury. Obviously, duration will be impacted by patient adherence, as well as availability of services. Clinical judgment may substantiate the need to accelerate or decelerate the time frames discussed in this document. Such deviation shall be in accordance with La. R.S. 23:1203.1

5. Active Interventions. Emphasizing patient responsibility, such as therapeutic exercise and/or functional treatment, are generally emphasized over passive modalities, especially as treatment progresses. Generally, passive interventions are viewed as a means to facilitate progress in an active rehabilitation program with concomitant attainment of objective functional gains.

6. Active Therapeutic Exercise Program. Exercise program goals should incorporate patient strength, endurance, flexibility, coordination, and education. This includes functional application in vocational or community settings.

7. Positive Patient Response. Positive results are defined primarily as functional gains that can be objectively measured.

a. Objective functional gains include, but are not limited to, positional tolerances, range-of-motion (ROM), strength, and endurance, activities of daily living, ability to function at work, cognition, psychological behavior, and efficiency/velocity measures that can be quantified. Subjective reports of pain and function should be considered and given relative weight when the pain has anatomic and physiologic correlation. Anatomic correlation must be based on objective findings.

8. Re-Evaluation of Treatment within Four Weeks. If a given treatment or modality is not producing positive results within four weeks, treatment should be either modified or discontinued. Reconsideration of diagnosis should also occur in the event of poor response to a seemingly rational intervention.

9. Surgical Interventions. Surgery should be contemplated within the context of expected improvement of functional outcome and not purely for the purpose of pain relief. The concept of "cure" with respect to surgical

treatment by itself is generally a misnomer. All operative interventions must be based upon positive correlation of clinical findings, clinical course, and diagnostic tests. A comprehensive assimilation of these factors must lead to a specific diagnosis with positive identification of pathologic conditions. The decision and recommendation for operative treatment, and the appropriate informed consent should be made by the operating surgeon. Prior to surgical intervention, the patient and treating physician should identify functional operative goals and the likelihood of achieving improved ability to perform activities of daily living or work activities and the patient should agree to comply with the pre- and post-operative treatment plan and home exercise requirements. The patient should understand the length of partial and full disability expected post-operatively.

10. Pharmacy-Louisiana Law and Regulation: All prescribing will be done in accordance with the laws of the state of Louisiana as they pertain respectively to each individual licensee, including, but not limited to: Louisiana State Board of Medical Examiners regulations governing medications used in the treatment of non-cancer-related chronic or intractable pain; Louisiana Board of Pharmacy Prescription Monitoring Program; Louisiana Department of Health and Hospitals licensing and certification standards for pain management clinics; other laws and regulations affecting the prescribing and dispensing of medications in the state of Louisiana.

11. Six Month-Time Frame. Injuries resulting in temporary total disability may require maintenance treatment and may not attain return to work in six months.

12. Return To Work. Return to work is therapeutic, assuming the work is not likely to aggravate the basic problem or increase long-term pain. An injured worker's return-to-work status shall not be the sole cause to deny reasonable and medically necessary treatment under these guidelines. Two good practices are: early contact with injured workers and provide modified work positions for short-term injuries. The practitioner must provide specific physical limitations and the patient should never be released to non-specific and vague descriptions such as "sedentary" or "light duty." The following physical limitations should be considered and modified as recommended: lifting, pushing, pulling, crouching, walking, using stairs, bending at the waist, awkward and/or sustained postures, tolerance for sitting or standing, hot and cold environments, data entry and other repetitive motion tasks, sustained grip, tool usage and vibration factors. Even if there is residual chronic pain, return-to-work is not necessarily contraindicated. The practitioner should understand all of the physical demands of the patient's job position before returning the patient to full duty and should request clarification of the patient's job duties. Clarification should be obtained from the employer or, if necessary, from including, but not limited to, occupational health nurse, physical therapist, occupational therapist, vocational rehabilitation specialist, chiropractor or another professional. American Medical Association clarifies "disability" as "activity limitations and/or participation

restrictions in an individual with a health condition, disorder or disease" versus "impairment" as "a significant deviation, loss, or loss of use of any body structure or body function in an individual with a health condition, disorder or disease".

13. Delayed Recovery. Within the discretion of the treating physician, strongly consider a psychological evaluation, if not previously provided, as well as initiating interdisciplinary rehabilitation treatment and vocational goal setting, for those patients who are failing to make expected progress 6 to 12 weeks after initiation of treatment of an injury. The OWCA recognizes that 3 to 10 percent of all industrially injured patients will not recover within the timelines outlined in this document despite optimal care. Such individuals may require treatments beyond the limits discussed within this document, but such treatment requires clear documentation by the authorized treating practitioner focusing on objective functional gains afforded by further treatment and impact upon prognosis.

14. Guideline Recommendations and Inclusion of Medical Evidence. All recommendations are based on available evidence and/or consensus judgment. It is generally recognized that early reports of a positive treatment effect are frequently weakened or overturned by subsequent research. Per R.S. 1203.1, when interpreting medical evidence statements in the guideline, the following apply to the strength of recommendation.

Strong	Level 1 Evidence	We Recommend
Moderate	Level 2 and Level 3 Evidence	We Suggest
Weak	Level 4 Evidence	Treatment is an Option
Inconclusive	Evidence is Either Insufficient or Conflicting	

a. Consensus guidelines are generated by a professional organization that the guidelines are intended to serve. A committee of specialists and experts are selected by the organization to create an unbiased, vetted recommendation for the treatment of specific issues within the realm of their expertise. All recommendations in the guideline are considered to represent reasonable care in appropriately selected cases, regardless of the level of evidence or consensus statement attached to it. Those procedures considered inappropriate, unreasonable, or unnecessary are designated in the guideline as "not recommended."

15. Treatment of Pre-Existing Conditions The conditions that preexisted the work injury/disease will need to be managed under two circumstances: (a) A pre-existing condition exacerbated by a work injury/disease should be treated until the patient has returned to their objectively verified prior level of functioning or Maximum Medical Improvement (MMI); and (b) A pre-existing condition not directly caused by a work injury/disease but which may prevent recovery from that injury should be treated until its objectively verified negative impact has been controlled. The focus of treatment should remain on the work injury/disease.

B. The remainder of this document should be interpreted within the parameters of these guideline principles that may

lead to more optimal medical and functional outcomes for injured workers.

**AUTHORITY NOTE:** Promulgated in accordance with R.S. 23:1203.1.

**HISTORICAL NOTE:** Promulgated by the Louisiana Workforce Commission, Office of Workers Compensation Administration, LR 37:1821 (June 2011), amended by the Louisiana Workforce Commission, Office of Workers Compensation, LR 40:1162 (June 2014), LR 49:521 (March 2023).

**§2319. Initial diagnostic procedures**

A. The OWCA recommends the following diagnostic procedures be considered, at least initially, the responsibility of the workers' compensation carrier to ensure that an accurate diagnosis and treatment plan can be established. Standard procedures that should be utilized when initially diagnosing a work-related shoulder complaint are listed below.

1. History Taking and Physical Examination (Hx and PE) are generally accepted, well-established and widely used procedures that establish the foundation/basis for and dictates subsequent stages of diagnostic and therapeutic procedures. List of medications patient is taking should be included in every history, including over the counter medicines as well as supplements. When findings of clinical evaluations and those of other diagnostic procedures are not complementing each other, the objective clinical findings should have preference. The medical records should reasonably document the following:

- a. History of Present Injury
  - i. Mechanism of injury. This includes details of symptom onset and progression, and documentation of right or left dominance;
  - ii. Relationship to work. This includes a statement of the probability that the illness or injury is work-related;
  - iii. Prior occupational and non-occupational injuries to the same area including specific prior treatment;
  - iv. History of locking, clicking, weakness, acute or chronic swelling, crepitation, pain while lifting or performing overhead work, dislocation or popping. Pain or catching with overhead motion may indicate a labral tear. Night time pain can be associated with specific shoulder pathology. Anterior joint pain, such as that seen in throwing athletes, may indicate glenohumeral instability. Pain radiating below the elbow, may indicate cervical disc problems or proximal entrapment neuropathy.
  - v. Ability to perform job duties and activities of daily living; and
  - vi. Exacerbating and alleviating factors of the reported symptoms. The physician should explore and report on non-work related as well as, work related activities.

- b. Past History
  - i. Past medical history includes previous shoulder conditions, neoplasm, gout, arthritis, diabetes and previous shoulder symptoms;

- ii. Review of systems includes symptoms of rheumatologic, neurologic, endocrine, neoplastic, and other systemic diseases;

- iii. Smoking history; and
- iv. Vocational and recreational pursuits.

c. Physical Examination: Examination should include the elbow and neck. Both shoulders should be examined to compare asymptomatic and symptomatic sides and identify individuals with non-pathological joint laxity or degenerative rotator cuff pathology. Physical examinations should consist of accepted tests and exam techniques applicable to the joint or area being examined, including:

- i. visual inspection;
- ii. palpation, including the acromio-clavicular (AC) joint, sternoclavicular joint, and the subacromial bursa in the region of the acromiohumeral sulcus;
- iii. range-of-motion/quality of motion;
- iv. strength, shoulder girdle weakness may indicate musculoskeletal or neurogenic pathology;
- v. joint stability;
- vi. integrity of distal circulation and limited neurologic exam;
- vii. cervical spine evaluation; and
- viii. if applicable, full neurological exam including muscle atrophy and gait abnormality.
- ix. specific shoulder tests

(a). This section contains a description of common clinical shoulder tests. Generally, more than one test is needed to make a diagnosis. Clinical judgment should be applied when considering which tests to perform, as it is not necessary to perform all of the listed tests on every patient. The physical examination may be non-specific secondary to multi-faceted pathology in many patients, and because some tests may be positive for more than one condition. Given the multitude of tests available, the physician is encouraged to document the specific patient response, rather than report that a test is 'positive.' The tests are listed for informational purposes, and are also referenced in Specific Diagnostic, Testing and Treatment Procedures.

(i). Rotator cuff/Impingement tests/Signs - Most published clinical examination studies assess rotator cuff pathology. There is some evidence that tests are reliable for ruling out diagnoses, but not necessarily defining the pathology accurately. Some studies indicate that the Neer test, Hawkins test, Jobe test, crossed-arm adduction test, impingement sign and arc of pain are approximately 80 percent sensitive for impingement or rotator cuff pathology. The drop arm, Yergason's, Speed, and passive external Rotation Tests are thought to have specificity of 60 percent or higher. (Questions remain about interrater reliability.)

[a].Weakness with abduction.

[b].Arc of pain – Pain with 60 to 120 degrees of abduction.

[c].Neer impingement sign – Examiner flexes arm anteriorly to reproduce impingement. Positive if pain is reproduced.

[d].Neer impingement test – When the Neer impingement sign is positive, the subacromial bursa is injected with local anesthetic. If, after 40 minutes, the patient has sufficient pain relief so that the examiner can perform the Neer impingement sign without recreating the initial pain, the test suggests impingement.

[e].Hawkins - arm is abducted to 90 degrees, forward flexed by 90 degrees with elbow flexed. Examiner internally rotates the humerus. Pain suggests impingement.

[f].Drop arm - Patient slowly lowers arm from full abduction. If the arm drops, or if the patient is unable to maintain slow progress from approximately 90 degrees, the test suggests rotator cuff tear.

[g].Lift off - patient's hand is placed against back of waist with 90 degrees flexion of elbow. The patient is asked to lift the hand off of his back at waist level. If the hand drops to the initial position against the back, this suggests subscapularis tear or weakness. Some patients may not be able to perform the initial hand placement due to pain or limited range-of-motion.

[h].Subscapularis strength test - Patient places hand on mid-abdomen, and then applies pressure. If the elbow moves posteriorly or the wrist flexes, the test suggests subscapularis weakness or tear.

[i].Empty Can test - Patient's arm abducted to 60 to 90 degrees with 30 degrees forward flexion and with forearm pronated. Thumbs are pointing toward the floor. Patient resists examiner's downward pressure on the elbow. Weakness of the affected side, compared to the opposite side, or pain in subacromial area suggests supraspinatus tear, tendonitis or tendonosis.

[j].External rotation lag test - the patient's arm is abducted to 20 degrees with elbow flexed at 90 degrees, and almost fully externally rotated. If the patient cannot maintain the arm in external rotation, this suggests a supraspinatus and/or infraspinatus tear.

[k].External rotation weakness – Elbows are flexed with arms at side, and patient attempts to externally rotate against resistance. Weakness suggests infraspinatus and teres minor pathology.

[l].Impingement sign – Patient extends shoulder, then abducts and reports any pain

(ii). Acromioclavicular Joint Tests

[a].Crossed arm adduction – Examiner adducts arm across the body as far as possible toward the opposite shoulder. If patient reports pain in the AC joint, this suggests AC joint pathology. Examiner may measure the distance between antecubital fossa and the opposite acromion of the opposite shoulder. If one shoulder demonstrates increased

distance compared to the other shoulder, this suggests a tight posterior capsule.

[b].Paxino's - The examiner's thumb is placed under the posterolateral aspect of the acromion, with the index and long fingers on the superior aspect of middle part of the clavicle. Examiner applies anterior superior pressure to acromion with thumb, and pushes inferiorly on the middle of the clavicle with index and long fingers. If the patient reports increased pain in the AC joint, the test suggests AC joint pathology.

(iii).Labral Tears

[a].Labral tears which may require treatment usually occur with concurrent bicipital tendon disorders pathology and/or glenohumeral instability. Therefore, tests for labral pathology are included in these sections.

(iv).Bicipital Tendon Disorders

[a].Yergason's Test - The patient has the elbow flexed to 90 degrees. The examiner faces the patient, grasps the patient's hand with one hand and palpates the bicipital groove with the other. The patient supinates the forearm against resistance. If the patient complains of pain in the biceps tendon with resistance, it suggests a positive finding.

[b].Ludington's - The patient's hands are placed behind the head, with the shoulders in abduction and external rotation. If biceps contraction recreates pain, the test suggests biceps tendon pathology.

[c].Speed Test - The patient's shoulder is flexed to 90 degrees and supinated. The examiner provides resistance to forward flexion. If pain is produced with resistance, the test suggests biceps tendon instability or tendonitis.

[d].Biceps Load Test II - The patient is supine with the arm elevated to 120 degrees, externally rotated to maximum point, with elbow in 90 degrees of flexion and the forearm supinated. The examiner sits adjacent to the patient on the same side, and grasps the patient's wrist and elbow. The patient flexes the elbow, while the examiner resists. If the patient complains of pain with resistance to elbow flexion, or if the pain is increased with resisted elbow flexion, this may suggest a biceps related SLAP lesion in young patients.

(v). Glenohumeral Instability/Labral Tears/SLAP Lesions. Many of the following tests are also used to test for associated labral tears. The majority of the tests/signs should be performed on both shoulders for comparison. Some individuals have increased laxity in all joints, and therefore, tests/signs which might indicate instability in one individual may not be pathologic in individuals whose asymptomatic joint is equally lax.

[a].Sulcus sign. With the patient's arm at the side, the examiner pulls inferiorly and checks for deepening of the sulcus, a large dimple on the lateral side of the shoulder. Deepening of the sulcus suggests instability.

[b].Inferior Instability. With patient’s arm abducted to 90 degrees, examiner pushes down directly on mid-humerus. Patient may try to drop the arm to the side to avoid dislocation.

[c].Posterior Instability. The patient’s arm is flexed to 90 degrees anteriorly and examiner applies posterior force to the humerus. The examiner then checks for instability.

[d].Apprehension. Patient’s shoulder is in 90 degrees of abduction and in external rotation. Examiner continues to externally rotate and apply axial force to the humerus. If there is pain, or if patient asks to stop, the test suggests anterior instability.

[e].Relocation – Examiner applies posterior force on humerus while externally rotating. This is performed in conjunction with the apprehension test. If symptoms are reduced, the test suggests anterior instability.

[f]. Load and shift or anterior and posterior drawer – Patient is supine or seated with arm abducted from shoulder from 20 to 90 degrees and elbow flexed. Humerus is loaded by examiner, then examiner attempts to shift the humeral head anterior, posterior, or inferior. Both shoulders should be tested. Results are graded using:

[i]. Grade 0, little or no movement;

[ii]. Grade 1, humeral head glides beyond the glenoid labrum; and

[iii]. Grades 2 & 3 actual dislocation of the humeral head off the glenoid.

[g].Anterior slide or Kibler test. Patient places hands on hips with thumb directed posteriorly. Examiner applies force superiorly and anteriorly on the humerus, while the patient resists. If a click or deep pain results, test suggests labral tear.

[h].Active Compression (O’Brien) Test. The patient has the shoulder in 90 degrees flexion and 10 to 15 degrees adduction. The arm is internally rotated so the thumb is pointing downward. The patient elevates the arm while the examiner resists. If the patient experiences deep anterior shoulder pain that is relieved when the same process is repeated with external rotation of the arm, the test suggests labral tear or AC joint pathology.

[i]. Crank Test. The patient is standing and has arm elevated to 160 degrees in the scapular plane. The examiner loads the glenohumeral joint while the arm is passively rotated internally and externally. The test is repeated in the supine position. Pain, clicking, popping, or other mechanical grinding suggests labral tear and possible instability.

[j].Compression Rotation Test. The patient is supine with shoulder abducted at 90 degrees. The examiner applies an axial load across the glenohumeral joint while simultaneously passively rotating the patient’s arm in internal and external rotation. Pain, clicking, popping, or

other mechanical grinding suggests a labral tear and possible instability.

[k].Pain Provocation or Mimori Test. The patient is seated upright with the shoulder in 90 degrees abduction. The examiner maximally pronates and supinates the forearm while maintaining the shoulder at 90 degrees abduction. A positive test is suggested when pain or pain severity, is greater with the forearm pronated.

(vi).Functional Assessment. The provider should assess the patient’s functional skills initially and periodically during treatment. The initial exam will form the baseline for the patient’s functional abilities post- injury. This assessment will help the physician and patient determine when progress is being made and whether specific therapies are having a beneficial effect. A number of functional scales are available that have been validated in clinical research settings. Many of these scales were developed to evaluate specific diagnoses and will not be useful for all patients with shoulder pain. The following areas are examples of functional activities the provider may assess:

[a].interference with sleep;

[b].difficulty getting dressed or combing or washing hair;

[c].ability to do the household shopping alone;

[d].ability to shower or bath and dry oneself using both hands;

[e].ability to carry a tray of food across a room with both hands;

[f].ability to hang up clothes in the closet;

[g].ability to reach high shelves with the affected shoulder;

[h].difficulty with any other activities including sports and work duties;

[i].concerns about putting on overhead clothing;

[j].concerns that a specific activity might cause the shoulder to “go out”;

[k].a detailed description of ability to perform job duties.

[l].any positive historical information should be validated by the provider’s physical exam.

2. Radiographic Imaging of the shoulder is a generally accepted, well-established and widely used diagnostic procedure when specific indications based on history and/or physical examination are present. It should not be routinely performed for most non-traumatic diagnoses. The mechanism of injury and specific indications for the radiograph should be listed on the request form to aid the radiologist and x-ray technician. For additional specific clinical indications, Specific Diagnosis, Testing and Treatment Procedures. Indications include:

- a. inability to actively move arm through range-of-motion;
- b. history of significant trauma, especially blunt trauma or fall from a height;
- c. history of dislocation;
- d. age over 55 years;
- e. unexplained or persistent shoulder pain over two weeks. (Occult fractures, may not be visible on initial x-ray. A follow-up radiograph and/or bone scan may be required to make the diagnosis);
- f. history or exam suggestive of intravenous drug abuse or osteomyelitis; and
- g. pain with swelling and/or range-of-motion (ROM) limitation localizing to an area of prior fracture, internal fixation, or joint prosthesis.

3. Laboratory tests are generally accepted, well-established and widely used procedures. They are, however, rarely indicated at the time of initial evaluation, unless there is suspicion of systemic illness, infection, neoplasia, connective tissue disorder, or underlying arthritis or rheumatologic disorder based on history and/or physical examination. Laboratory tests can provide useful diagnostic information. The OWCA recommends that lab diagnostic procedures be initially considered the responsibility of the workers' compensation carrier to ensure that an accurate diagnosis and treatment plan can be established. Tests include, but are not limited to:

- a. Completed Blood Count (CBC) with differential can detect infection, blood dyscrasias, and medication side effects;
- b. Erythrocyte sedimentation rate, rheumatoid factor, antinuclear antigen (ANA), human leukocyte antigen (HLA), and C-reactive protein can be used to detect evidence of a rheumatologic, infection, or connective tissue disorder;
- c. Serum calcium, phosphorous, uric acid, alkaline phosphatase, and acid phosphatase can detect metabolic bone disease;
- d. Liver and kidney function may be performed for prolonged anti-inflammatory use or other medications requiring monitoring; and
- e. Analysis of joint aspiration for bacteria, white cell count, red cell count, fat globules, crystalline birefringence and chemistry to evaluate joint effusion.

#### 7. Other Procedures

a. Joint Aspiration: is a generally accepted, well-established and widely used procedure when specifically indicated and performed by individuals properly trained in these techniques. Especially, when history and/or physical examination are of concern for a septic joint or bursitis. Aspiration of a large effusion can help to decrease pain and speed functional recovery. Persistent or unexplained effusions may be examined for evidence of infection,

rheumatologic, or inflammatory processes. The presence of fat globules in the effusion strongly suggests occult fracture.

AUTHORITY NOTE: Promulgated in accordance with R.S. 23:1203.1.

HISTORICAL NOTE: Promulgated by the Louisiana Workforce Commission, Office of Workers Compensation Administration, LR 37:1822 (June 2011), LR 49:522 (March 2023).

#### **§2321. Follow-Up diagnostic imaging and testing procedures**

A. One diagnostic imaging procedure may provide the same or distinctive information as does another procedure. Therefore, the prudent choice of a single diagnostic procedure, a complement of procedures or a sequence of procedures will optimize diagnostic accuracy; maximize cost effectiveness (by avoiding redundancy), and minimize potential adverse effects to patients.

B. All diagnostic imaging procedures have a significant percentage of specificity and sensitivity for various diagnoses. None is specifically characteristic of a certain diagnosis. Clinical information obtained by history taking and physical examination should form the basis for selecting an imaging procedure and interpreting its results.

C. When a diagnostic procedure, in conjunction with clinical information, can provide sufficient information to establish an accurate diagnosis, the second diagnostic procedure will become a redundant procedure. At the same time, a subsequent diagnostic procedure can be a complementary diagnostic procedure if the first or preceding procedures, in conjunction with clinical information, cannot provide an accurate diagnosis. Usually, preference of a procedure over others depends upon availability, a patient's tolerance, and/or the treating practitioner's familiarity with the procedure.

1. Imaging Studies are generally accepted, well-established and widely used diagnostic procedures. When indicated, the following additional imaging studies can be utilized for further evaluation of the shoulder, based upon the mechanism of injury, symptoms, and patient history. For specific clinical indications, refer to Specific Diagnosis, Testing and Treatment Procedures. The studies below are listed by frequency of use, not importance. Diagnostic imaging may be useful in resolving the diagnostic uncertainties that remain after the clinical examination. Even a thorough history and physical examination may not define the shoulder pathology that produces the patient's symptoms. Therefore, additional investigations should be considered as an accepted part of the patient evaluation when surgery is being considered or clarification of diagnosis is necessary to formulate a treatment plan.

a. X-ray is widely accepted and frequently the first imaging study performed. Three radiographically distinguishable acromion types have been described: Type I (flat), Type II (curved), and Type III (hooked). Historically, acromion type was correlated with incidence of rotator cuff pathologies and with outcome of nonsurgical treatment of shoulder pain. However, there is considerable variation between observers regarding the acromial types, both in

interpreting plain x-rays and in classifying anatomical specimens. Acromial morphology should not be used to assess the likelihood of rotator cuff pathology. Acromial morphology alone should not be considered an indication for acromioplasty, as up to 40 percent of asymptomatic adults may have a Type II acromion. Appropriate soft tissue imaging techniques such as sonography and MRI should be used to assess rotator cuff or bursa status.

b. Diagnostic Sonography is an accepted technique for suspected full-thickness tears. A positive sonogram has a high specificity of 96 percent and provides convincing confirmation of the diagnosis. Sensitivity is high, 87 percent, however, negative sonography does not rule out a full-thickness tear. For partial thickness tears, a positive sonogram has high specificity, 94 percent, but is only moderately sensitive, 67 percent. A negative sonogram does not exclude the diagnosis of a partial thickness tear. The performance of sonography is operator-dependent, and is best when done by a specialist in musculoskeletal radiology. It is preferable to MRI when the patient is claustrophobic or has inserted medical devices.

c. Magnetic Resonance Imaging (MRI) is generally accepted and widely used to provide a more definitive visualization of soft tissue structures, including ligaments, tendons, joint capsule, and joint cartilage structures, than x-ray or Computed Axial Tomography (CT) in the evaluation of traumatic or degenerative injuries. The addition of intravenous or intra-articular contrast can enhance definition of selected pathologies. In general, the high field, conventional, MRI provides better resolution than a low field scan. A lower field scan may be indicated when a patient cannot fit into a high field scanner or is too claustrophobic despite sedation. Inadequate resolution on the first scan may require a second MRI using a different technique. All questions in this regard should be discussed with the MRI center and/or radiologist. MRI provides excellent soft tissue detail, but interpretation of the image is problematic and depends on operator skill. A positive MRI has high specificity of 93 percent and provides supporting evidence that a clinical suspicion of a full-thickness tear is correct. Sensitivity of MRI for full-thickness tears is also high at 89 percent. However, it may not identify the pathology in some cases. For partial thickness tears, sensitivity of MRI is below 50 percent but its specificity is high at 90 percent.

d. Computed Axial Tomography (CT): is generally accepted and provides excellent visualization of bone and is used to further evaluate bony masses and suspected fractures not clearly identified on radiographic window evaluation. Instrument scatter-reduction software provides better resolution when metallic artifact is of concern.

e. MR Arthrography (MRA): This accepted investigation uses the paramagnetic properties of gadolinium to shorten T1 relaxation times and provide a more intense MRI signal. It can accurately demonstrate and rule out full-thickness tears as well as non-contrast MRI, but it is invasive and its place in the evaluation of rotator cuff pathology has not been determined. In select populations of highly active

athletes, it may uncover unsuspected labral pathology such as SLAP lesions, but the arthroscopically normal labrum may produce an abnormal signal in half of MRA studies. Its contribution to the diagnosis of SLAP lesions has not been determined. An MRA is not necessary if the patient has already met indications for arthroscopy or surgery as outlined in Specific Diagnosis, Testing and Treatment. However, an MRA may be ordered when the surgeon desires further information prior to surgery.

f. Venogram/Arteriogram is a generally accepted test is useful for investigation of vascular injuries or disease, including deep-venous thrombosis. Potential complications may include pain, allergic reaction, and deep-vein thrombosis.

g. Bone Scan (Radioisotope Bone Scanning): is generally accepted, well-established and widely used. Bone scanning is more sensitive but less specific than MRI. <sup>99m</sup>Techneceium diphosphonate uptake reflects osteoblastic activity and may be useful in metastatic/primary bone tumors, stress fractures, osteomyelitis, and inflammatory lesions, but cannot distinguish between these entities. Bone scanning is more sensitive but less specific than MRI. It is useful for the investigation of trauma, infection, stress fracture, occult fracture, Complex Regional Pain Syndrome, and suspected neoplastic conditions of the upper extremity.

h. Other Radioisotope Scanning Indium and gallium scans are generally accepted procedures usually to help diagnose lesions seen on other diagnostic imaging studies. <sup>67</sup>Gallium citrate scans are used to localize tumor, infection, and abscesses. <sup>111</sup>Indium-labeled leukocyte scanning is utilized for localization of infection or inflammation.

i. Arthrograms are accepted; however, rarely used except for evaluation of patients with metal implants and previous shoulder surgery.

j. If the patient has a positive ultrasound, MRI, or Arthrogram—only one of these tests are necessary to diagnose a rotator cuff tear. Any additional tests must be for additional diagnosis.

k. Diagnostic Arthroscopy (DA) allows direct visualization of the interior of a joint, enabling the diagnosis of conditions when other diagnostic tests have failed to reveal an accurate diagnosis; however, it should generally not be employed for exploration purposes only. In order to perform a diagnostic arthroscopy, the patient must have completed at least some conservative therapy without sufficient functional recovery and meet criteria for arthroscopic repair.

i. DA may also be employed in the treatment of acute joint disorders. In some cases, the mechanism of injury and physical examination findings will strongly suggest the presence of a surgical lesion. In those cases, it is appropriate to proceed directly with the interventional arthroscopy

3. Other Tests. The following diagnostic procedures in this subsection are listed in alphabetical order.



a. Compartment Pressure Testing and Measurement Devices: such as pressure manometer, are generally accepted and useful in the evaluation of patients who present uncommon but reported symptoms consistent with a compartment syndrome.

b. Doppler Ultrasonography/Plethysmography: is useful in establishing the diagnosis of arterial and venous disease in the upper extremity and should be considered prior to the more invasive venogram or arteriogram study.

c. Electrodiagnostic Testing: Electrodiagnostic tests include but are not limited to, Electromyography (EMG), and Nerve Conduction Studies (NCS). These are generally accepted, well-established and widely used diagnostic procedures. Electrodiagnostic studies may be useful in the evaluation of patients with suspected involvement of the neuromuscular system, including radiculopathies, peripheral nerve entrapments, peripheral neuropathies, disorders of the neuromuscular junction and primary muscle disease. EMGs should not be routinely performed for shoulder injuries unless there are findings to suggest new diagnostic pathology (Refer to Brachial Plexus). In general, these diagnostic procedures are complementary to imaging procedures such as CT, MRI, and/or myelography or diagnostic injection procedures. Electrodiagnostic studies may provide useful, correlative neuropathophysiological information that would not be obtainable from standard radiologic studies. Portable Automated Electrodiagnostic Device (also known as Surface EMG) is not a substitute for conventional EMG/NCS testing in clinical decision-making, and therefore, is not recommended.

d. Personality/Psychological/Psychiatric/Psychosocial Evaluation: These are generally accepted and well-established diagnostic procedures with selective use in the upper extremity population, but have more widespread use in subacute and chronic upper extremity populations. Diagnostic testing procedures may be useful for patients with symptoms of depression, delayed recovery, chronic pain, recurrent painful conditions, disability problems, and for preoperative evaluation. Psychological/psychosocial and measures have been shown to have predictive value for postoperative response, and therefore should be strongly considered for use pre-operatively when the surgeon has concerns about the relationship between symptoms and findings, or when the surgeon is aware of indications of psychological complication or risk factors for psychological complication (e.g. childhood psychological trauma). Psychological testing should provide differentiation between pre-existing conditions versus injury caused psychological conditions, including depression and posttraumatic stress disorder. Psychological testing should incorporate measures that have been shown, empirically, to identify comorbidities or risk factors that are linked to poor outcome or delayed recovery. Formal psychological or psychosocial evaluation should be performed on patients not making expected progress within 6 to 12 weeks following injury and whose subjective symptoms do not correlate with objective signs and test results. In addition to the customary initial exam, the

evaluation of the injured worker should specifically address the following areas:

- i. employment history;
- ii. interpersonal relationships-both social and work;
- iii. patient activities;
- iv. current perception of the medical system;
- v. current perception/attitudes toward employer/job
- vi. results of current treatment
- vii. risk factors and psychological comorbidities that may influence outcome and that may require treatment
- viii. childhood history, including history of childhood psychological trauma, abuse and family history of disability.

(a). Personality/ psychological/ psychosocial evaluations consist of two components, clinical interview and psychological testing. Results should help clinicians with a better understanding of the patient in a number of ways. Thus the evaluation result will determine the need for further psychosocial interventions; and in those cases, Diagnostic and Statistical Manual of Mental Disorders (DSM) diagnosis should be determined and documented. The evaluation should also include examination of both psychological comorbidities and psychological risk factors that are empirically associated with poor outcome and/or delayed recovery. An individual with a Ph.D., Psy.D, or psychiatric M.D./D.O. credentials should perform initial evaluations, which are generally completed within one to two hours. A professional fluent in the primary language of the patient is preferred. When such a provider is not available, services of a professional language interpreter should be provided.

(i). Frequency: one-time visit for the clinical interview. If psychometric testing is indicated as a part of the initial evaluation, time for such testing should not exceed an additional two hours of professional time.

4. Special Tests are generally well-accepted tests and are performed as part of a skilled assessment of the patient's capacity to return-to-work, his/her strength capacities, and physical work demand classifications and tolerances. The procedures in this subsection are listed in alphabetical order.

a. Computer Enhanced Evaluations: may include isotonic, isometric, isokinetic and/or isoinertial measurement of movement, range-of-motion (ROM), endurance or strength. Values obtained can include degrees of motion, torque forces, pressures, or resistance. Indications include determining validity of effort, effectiveness of treatment and demonstrated motivation. These evaluations should not be used alone to determine return to work restrictions. The added value of computer enhanced evaluations is unclear. Targeted work tolerance screening or gradual return to work is preferred.

i. Frequency: One time for evaluation. Can monitor improvements in strength every three to four weeks up to a total of six evaluations.

b. Functional Capacity Evaluation (FCE): is a comprehensive or modified evaluation of the various aspects of function as they relate to the worker's ability to return-to-work. Areas such as endurance, lifting (dynamic and static), postural tolerance, specific range of motion, coordination and strength, worker habits, employability, as well as psychosocial aspects of competitive employment may be evaluated. Components of this evaluation may include: musculoskeletal screen; cardiovascular profile/aerobic capacity; coordination; lift/carrying analysis; job-specific activity tolerance; maximum voluntary effort; pain assessment/psychological screening; and non-material and material handling activities. When an FCE is being used to determine return to a specific jobsite, the provider is responsible for fully understanding the job duties. A jobsite evaluation is frequently necessary. FCEs cannot be used in isolation to determine work restrictions. The authorized treating physician must interpret the FCE in light of the individual patient's presentation and medical and personal perceptions. FCEs should not be used as the sole criteria to diagnose malingering. Full FCEs are sometimes not necessary. If Partial FCEs are performed, it is recognized that all parts of the FCE that are not performed are considered normal. In many cases, a work tolerance screening will identify the ability to perform the necessary job tasks.

i. Frequency: Can be used initially to determine baseline status and for case closure when patient is unable to return to pre-injury position and further information is desired to determine permanent work restrictions. Prior authorization is required for FCEs performed during treatment.

c. Jobsite Evaluation: is a comprehensive analysis of the physical, mental, and sensory components of a specific job. These components may include, but are not limited to; postural tolerance (static and dynamic); aerobic requirements; range of motion; torque/force; lifting/carrying; cognitive demands; social interactions; visual perceptual; sensation; coordination; environmental requirements of a job; repetitiveness; and essential job functions. Job descriptions provided by the employer are helpful but should not be used as a substitute for direct observation. A jobsite evaluation may include observation and instruction of how work is done, what material changes (desk, chair) should be made, and determination of readiness to return to work. Requests for a jobsite evaluation should describe the expected goals for the evaluation. Goals may include, but are not limited to the following:

i. To determine if there are potential contributing factors to the person's condition and/or for the physician to assess causality;

ii. To make recommendations for, and to assess the potential for ergonomic changes;

iii. To provide a detailed description of the physical and cognitive job requirements;

iv. To assist the patient in their return to work by educating them on how they may be able to do their job more safely in a bio-mechanically appropriate manner; and/or

v. To give detailed work/activity restrictions.

(a). Frequency: One time with additional visits as needed for follow-up visits per jobsite.

d. Vocational Assessment: The vocational assessment should provide valuable guidance in the determination of future rehabilitation program goals. It should clarify rehabilitation goals, which optimize both patient motivation and utilization of rehabilitation resources. If prognosis for return to former occupation idetermined to be poor, except in the most extenuating circumstances, vocational assessment should be implemented within 3 to 12 months post-injury. Declaration of MMI should not be delayed solely due to lack of attainment of a vocational assessment.

i. Frequency: One time with additional visits as needed for follow-up

e. Work Tolerance Screening: is a determination of an individual's tolerance for performing a specific job based on a job activity or task and may be used when a full Functional Capacity Evaluation is not indicated. The screening is monitored by a therapist and may include a test or procedure to specifically identify and quantify work-relevant cardiovascular, physical fitness and postural tolerance. It may also address ergonomic issues affecting the patient's return-to-work potential.

i. Frequency: One time for initial screen. May monitor improvements in strength every three to four weeks up to a total of six visits.

AUTHORITY NOTE: Promulgated in accordance with R.S. 23:1203.1.

HISTORICAL NOTE: Promulgated by the Louisiana Workforce Commission, Office of Workers Compensation Administration, LR 37:1825 (June 2011), LR 49:522 (March 2023).

**§2323. Specific Diagnosis, Testing and Treatment**

A. Acromioclavicular joint sprains/dislocations. An acute acromioclavicular (AC) joint injury is frequently referred to as a shoulder separation. There are six classifications of AC joint separation, which are based upon the extent of ligament damage and bony displacement:

1. Description/Definition:

a. Type I - Sprain of the AC ligament and capsule; x-ray usually normal.

b. Type II - Sprains consisting of a ruptured AC ligament and capsule with incomplete injury to the coracoclavicular (CC) ligament, resulting in mild AC joint subluxation. X-ray shows clavicle slightly elevated.

c. Type III - Dislocation of the clavicle above the acromion with complete tear of the AC ligament and/or CC ligaments; abnormal stress x-rays.

d. Type IV. - Dislocation consisting of a displaced clavicle that penetrates posteriorly through or into the trapezius muscle. The sterno-clavicular joint may also be dislocated.

e. Type V - Dislocation consisting of complete separation of the AC and CC ligaments and dislocation of the acromioclavicular joint with a large coracoclavicular interval.

f. Type VI - Dislocation consisting of a displaced clavicle that penetrates inferior to the coracoid.

2. Type I-III are common, while Types IV-VI are not, and when found require surgical consultation. For AC joint degeneration from repetitive motion that is found to be work-related, refer to Impingement Syndrome.

3. Occupational Relationship: Generally, workers sustain an AC joint injury when they fall landing on the point of the shoulder, driving the acromion downward; or fall on an outstretched hand or elbow with an adducted arm, creating a backward and outward force on the shoulder. It is important to rule out other sources of shoulder pain from the acute injury, including rotator cuff tear, fracture, and nerve injury.

4. Specific Physical Exam Findings may include the following:

a. At times, tenderness at the AC joint with contusions and/or abrasions at the joint area; and/or prominence/asymmetry of the shoulder can be seen;

b. The patient usually demonstrates decreased shoulder motion, and with palpation, the distal end of the clavicle is painful. There may be increased clavicular translation and cross-body adduction that causes exquisite pain at the AC joint. Cross-body adduction with the arm elevated to 90 degrees can also cause posterior pain with a tight posterior capsule, or lateral pain with impingement. Injection of local anesthetic in the AC joint should relieve pain when performing this maneuver.

5. Diagnostic Testing Procedures: Plain x-rays may include:

a. AP view;

b. AP radiograph of the shoulder with the beam angled 10 degrees cephalad (Zanca view) and a beam strength that is under-penetrating;

c. Axillary lateral views; and

d. Stress view; side-to-side comparison with 10 to 15 lb. of weight in each hand.

6. Non-operative Treatment Procedures may include:

a. Procedures outlined in Section F. Immobilization in some cases (up to 6 weeks for Type I-III AC joint

separations). Treatments for Type III injuries are controversial and may range from a sling to surgery.

b. Medication, such as non-steroidal anti-inflammatories and analgesics would be indicated. Narcotics are not normally indicated. Lidocaine patches may be used for pain relief. In chronic acromioclavicular joint pain, a series of injections with or without cortisone may be performed up to three times per year. Benefits may be achieved through therapeutic rehabilitation. It should emphasize a progressive increase in range-of-motion (ROM) without exacerbation of the AC joint injury. Full recovery of AC joint dislocation may require up to twelve weeks. With increasing motion and pain control, a strengthening program should be instituted. Refer to Therapeutic Procedures, Non-operative.

c. Return to appropriate modified duty should begin within the first week. Refer to Return to Work. With restoration of full-motion, return to full-duty should be anticipated within three months.

d. Other therapies in Therapeutic Procedures, Non-operative, may be employed in individual cases.

7. Surgical Indications: Patients who have Type III AC joint dislocations will usually recover well without surgical intervention. Surgical intervention may be considered when functional deficits interfere with activities of daily living and/or job duties after three to four months of active patient participation in non-operative therapy. For patients with particularly high physical demands on their shoulder, immediate orthopaedic consultation with surgical intervention as early as two weeks from the date of injury may be considered. Prior to surgical intervention, the patient and treating physician should identify functional operative goals and the likelihood of achieving improved ability to perform activities of daily living or work activities. The patient should also agree to comply with the pre- and post-operative treatment plan and home exercise requirements and understand the length of partial and full-disability expected post-operatively. With a Type IV-VI AC joint injury, an orthopedic surgical consultation is recommended.

8. Operative Procedures

a. AC joint stabilization with or without distal clavicle resection. Distal clavicle resection may prevent painful arthritis but can compromise post-operative AC joint stabilization.

9. Post-Operative Treatment

a. An individualized rehabilitation program based upon communication between the surgeon and the therapist using the treatments found in Therapeutic Procedures, Non-operative.

b. Early therapeutic rehabilitation interventions are recommended to maintain ROM with progressive strengthening.

i. Frequency: Three to five times per week for the first two weeks, three times per week for the following two weeks, then one to two times per week.

ii. Optimum Duration: Six to eight weeks with progression to home exercise and/or pool therapy.

iii. Maximum Duration: 12 weeks. Occasional follow-up visits may be justified to reinforce exercise patterns or to reach final functional goals if the therapy to date has demonstrated objective functional gains.

c. Return to work and restrictions after surgery may be made by an experienced primary occupational medicine physician in consultation with the surgeon or by the surgeon.

10. Adhesive Capsulitis/Frozen Shoulder Disorder

a. Description/Definition: Adhesive capsulitis of the shoulder, also known as frozen shoulder disorder, is a soft tissue lesion of the glenohumeral joint resulting in global restrictions of passive and active ROM. Lack of passive ROM can persist even with therapy, for an average of 30 months. The disorder progresses through stages, specifically:

i. Stage 1—Consists of acute pain with some limitation in range-of-motion; generally lasting two to nine months.

ii. Stage 2—Characterized by progressive stiffness, loss of passive range-of-motion, muscular atrophy, and decreased pain; generally lasting an additional 3 to 12 months beyond Stage 1.

iii. Stage 3—Characterized by partial or complete resolution of symptoms and restoration of ROM and strength; it usually takes an additional 5 to 26 months beyond Stage 2.

iv. Patients will usually complain of pain in the sub-deltoid region, but occasionally over the long head of the biceps or radiating down the lateral aspect of the arm to the forearm. Pain is often worse at night, with difficulty sleeping on the involved side. Motion is restricted and painful.

v. In Stages 2 and 3, patients may also experience peri-scapular and neck pain from compensatory scapular thoracic motion.

vi. Idiopathic adhesive capsulitis usually occurs spontaneously without any specific inciting injury. This occurs most frequently in diabetic, middle aged patients. This type of adhesive capsulitis is likely to remit over time and is usually not work related.

vii. Capsulitis or stiffness may occur secondary to trauma or surgery from another condition. Therapy and additional treatment recommendations for other specific diagnoses should be strictly followed to decrease the occurrence of secondary restricted ROM.

b. Specific Physical Exam Findings may include: Restricted active and passive glenohumeral ROM in multiple planes is the primary physical finding. It may be useful for the examiner to inject the subacromial space with lidocaine and then repeat ROM testing to rule out stiffness secondary to rotator cuff or bursal pathology. Lack of improvement of ROM usually confirms the diagnosis. Postural changes and

secondary trigger points along with atrophy of the deltoid and supraspinatus muscles may be seen.

c. Diagnostic Testing Procedures:

i. Plain x-rays should be done to rule out concomitant pathology such as subluxation or tumor.

ii. Other diagnostic testing may be indicated to rule out associated pathology. Refer to Follow-up Diagnostic Procedures and to Specific Diagnosis, Testing, and Treatment. Dynamic sonography may be useful to specifically identify the movements most affected and rule out other pathology.

iii. Laboratory tests should be considered to rule out systemic diseases.

d. Non-operative Treatment Procedures: Address the goal to restore and maintain function and may include the following:

i. Therapeutic interventions are the mainstay of treatment. They should include ROM, active therapies, and a home exercise program. Passive as well as active therapies may be used for control of pain and swelling. Therapy should progress to strengthening and instruction in a home exercise program targeted to further improve ROM and strength of the shoulder girdle musculature. There is some evidence that a home exercise program will have similar results to fully-supervised physical therapy in non-workers compensation populations; however, to facilitate return to work, supervised therapy is generally recommended for at least several sessions to assure proper performance of home exercise and to evaluate continued progress. These sessions are in addition to any sessions already performed for the original primary related diagnosis. Refer to Therapeutic Procedures, Non-operative for all other therapies as well as a description of active and passive therapies.

(a). Time to Produce Effect: Four sessions.

(b). Frequency: Two times per week for the first two weeks and one time or less thereafter.

(c). Optimum Duration: 8 to 12 sessions.

(d). Maximum Duration: 20 sessions per year. Additional follow-up visits may be justified to reinforce exercise patterns or to reach final functional goals if therapy to date has demonstrated objective functional gains.

ii. Return to work duties with increased ROM as tolerated are also helpful to increase function. Refer to Return to Work.

iii. Medications, such as NSAIDS and analgesics, may be helpful. Narcotics are indicated for post-manipulation or post-operative cases. Judicious use of pain medications to optimize function may be indicated. Refer to Medications.

iv. Subacromial bursal and/or glenohumeral steroid injections can decrease inflammation and allow the therapist to progress with functional exercise and ROM. There is strong evidence that intra-articular injection of a

corticosteroid produces pain relief and increases ROM in the short-term for individuals with restriction of both active and passive ROM in more than one direction. There is good evidence that the addition of a physical therapy or home exercise program is more effective than steroid injections alone. Injections under significant pressure should be avoided as the needle may be penetrating the tendon and injection into the tendon can cause possible tendon breakdown, tendon degeneration, or rupture. Injections should be minimized for patients under 30 years of age. Steroid injections should be used cautiously in diabetic patients. Diabetic patients should be reminded to check their blood glucose level at least daily for 2 weeks after injections.

(a). Time to Produce Effect: One injection.

(b). Maximum Duration: Three injections in one year at least four to eight weeks apart, when functional benefits are demonstrated with each injection.

v. There is no clear long-term benefit for suprascapular nerve blocks, however, blocks may be appropriate for patients when pain is not well-controlled and injections improve function.

(a). Time to Produce Effect: One block should demonstrate increased ability to perform exercises and/or range-of-motion.

(b). Maximum Duration: Three per year.

vi. In cases that are refractory to conservative therapy lasting at least three to six months, and in whom ROM remains significantly restricted (abduction usually less than 90 degrees), the following treatment may be considered:

(a). Distension arthrography or “brisement” in which saline, an anesthetic and usually a steroid are forcefully injected into the shoulder joint causing disruption of the capsule. There is good evidence that distension arthrogram with steroid and saline improves function in patients with decreased passive ROM after three months of treatment. Early therapy to maintain ROM, and restore strength and function should follow distension arthrography. Return to work with restrictions should be expected within one week of the procedure; return to full-duty is expected within four to six weeks.

(b). Dynamic splinting may be appropriate for rare cases when a functional ROM has not been achieved with the treatment listed above.

vii. There is no evidence that hyaluronate injections are superior to physical therapy in this condition and are not recommended.

viii. Other therapies in Therapeutic Procedures, Non-operative, may be employed in individual cases.

e. Surgical Indications: Surgery may be considered when functional deficits interfere with activities of daily living and/or job duties after three to six months of active patient participation in non-operative therapy. For most individuals this constitutes limitations in the range of 130

degrees elevation and 120 degrees abduction; with significant functional limitations; however, individuals who must perform overhead work and lifting may require a greater ROM. Prior to surgical intervention, the patient and treating physician should identify functional operative goals and the likelihood of achieving improved ability to perform activities of daily living or work activities. The patient should also agree to comply with the pre- and post-operative treatment plan and home exercise requirements. The patient should understand the length of partial and full disability expected post-operatively.

f. Operative Procedures: Manipulation under anesthesia which may be done in combination with steroid injection, distension arthrography, or arthroscopy. Contraindications to closed manipulation under anesthesia include anti-coagulation or bleeding diatheses, significant osteopenia, or recent surgical repair of shoulder soft tissue, fracture or neurological lesion. Complications may include humeral fracture, dislocation, cuff injuries, labral tears or brachial plexus injury. Arthroscopic capsular release or open surgical release may be appropriate in rare cases with failure of previous methods and when the patient has demonstrated ability to follow through with required physical and occupational therapy. Other disorders, such as impingement syndrome, may also be treated at the same time. Radiofrequency is not recommended due to reported complications from chondrolysis.

g. Post-Operative Treatment. An individualized rehabilitation program based upon communication between the surgeon and the therapist using the treatments found in Therapeutic Procedures, Non-operative. Therapy may include the following:

i. Early therapeutic rehabilitation interventions are recommended to maintain ROM and should progress to strengthening exercises.

ii. Frequency: Suggested frequency pattern is three to five times per week for the first two weeks, three times per week for the following two weeks, then one to two times per week. The exact frequency per week will depend on the severity.

iii. Optimum Duration: Six to eight weeks with progression to home exercise and/or pool therapy.

iv. Maximum Duration: Up to 12 weeks. Additional follow-up visits may be justified to reinforce exercise patterns or to reach final functional goals if the therapy to date has demonstrated objective functional gains.

v. Return to work and restrictions after surgery may be made by an experienced primary occupational medicine physician in consultation with the surgeon or by the surgeon.

vi. Patient should be approaching MMI within 8 to 12 weeks post-operatively; however, co-existence of other pathology should be taken into consideration.

## B. Bicipital Tendon Disorders

### 1. Description/Definition:

a. Disorders may include: primary bicipital tendonopathy, which is exceedingly rare; secondary bicipital tendonopathy, which is generally associated with rotator cuff tendonitis or impingement syndrome (see appropriate diagnosis subsections); subluxation of the biceps tendon, which occurs with dysfunction of the transverse inter-tubercular ligament and rotator cuff tears; and acute disruption of the tendon, which can result from an acute distractive force or transection of the tendon from direct trauma.

b. Symptoms may include aching, burning and/or stabbing pain in the shoulder, usually involving the anterior medial portion of the shoulder girdle. The symptoms are exacerbated with above-the-shoulder activities and those specifically engaging the biceps (flexion at the shoulder, flexion at the elbow and supination of the forearm). Relief occurs with rest. Patients may report nocturnal symptoms which interfere with sleep during the acute stages of inflammation; pain and weakness in shoulder during activities; repeated snapping phenomenon with a subluxing tendon; immediate sharp pain and tenderness along the course of the long head of the biceps following a sudden trauma which would raise suspicions of acute disruption of the tendon; and/or with predominant pain at the shoulder accompanied by referral patterns which may extend pain into the cervical or distal structures, including the arm, elbow, forearm, and wrist.

2. Occupational Relationship.

a. Bicipital tendon disorders may include symptoms of pain and/or achiness that occur after repetitive use of the shoulder and/or blunt trauma to the shoulder. Secondary bicipital tendonitis may be associated with prolonged above-the-shoulder activities, and/or repeated shoulder flexion, external rotation and abduction. Acute trauma to the biceps tendon of the shoulder girdle may also give rise to occupational injury of the biceps tendon.

b. Occupational disorders of the biceps tendon may accompany scapulothoracic dyskinesia, rotator cuff injury, AC joint separation, sub deltoid bursitis, shoulder instability or other shoulder pathology. Symptoms should be exacerbated or provoked by work that activated the biceps muscle. Symptoms may be exacerbated by other activities that are not necessarily work related and the physician should explore and report these areas.

3. Specific Physical Exam Findings may include the following:

a. If continuity of the tendon has been lost (biceps tendon rupture), inspection of the shoulder would reveal deformity (biceps bunching/Popeye deformity). It is important to differentiate between distal and proximal tendon rupture, as distal biceps ruptures often require urgent intervention.

b. Palpation demonstrates tenderness along the course of the bicipital tendon.

c. Pain at end range of flexion and abduction as well as with biceps tendon activation.

d. Provocative testing may include the following (a detailed description of the signs and tests is located in initial diagnostic procedures):

- i. Yergeson's sign.
- ii. Speed's Test.
- iii. Ludington's Test.
- iv. Diagnostic Testing Procedures:

(a). Plain x-rays include:

(i). Anterior/Posterior (AP) view. Elevation of the humeral head is indicative of a rotator cuff tear;

(ii). Lateral view in the plane of the scapula or an axillary view determines an anterior or posterior dislocation or the presence of a defect in the humeral head (a Hill-Sachs lesion);

(iii). Axillary view is also useful to demonstrate arthritis and spurs on the anterior inferior acromion; and

(iv). Outlet view determines if there is a downwardly tipped acromion.

(b). Adjunctive testing, such as sonography, or MRI should be considered when shoulder pain is refractory to four to six weeks of non-operative conservative treatment and the diagnosis is not readily identified by standard radiographic and clinical techniques.

4. Non-Operative Treatment Procedures:

a. Benefit may be achieved through procedures outlined in Non-operative Treatment Procedures, such as appropriate modalities, limited acute immobilization, exercise and evaluation of occupational workstation. Therapy should emphasize progressive increase in ROM. With increasing motion and pain control, a strengthening program should be instituted.

- i. Time to Produce Effect: Four sessions.
- ii. Frequency: Two times per week for the first two weeks and one time or less thereafter.
- iii. Optimum Duration: 8 to 12 sessions.
- iv. Maximum Duration: 20 sessions per year.

b. Medication, such as nonsteroidal anti-inflammatory and analgesics would be indicated. Narcotics are not normally indicated.

c. Biceps tendon sheath or subacromial steroid injections may be therapeutic. Injections under significant pressure should be avoided as the needle may be penetrating the tendon. Injection into the tendon can cause tendon degeneration, tendon breakdown, or rupture. Caution should be used in patients with a clinical suspicion of a partial tear. Injections should be minimized for patients under 30 years of age.

d. Steroid injections should be used cautiously in diabetic patients. Diabetic patients should be reminded to

check their blood glucose level at least daily for two weeks after injections.

i. Time to Produce Effect: One injection should provide demonstrable functional benefit.

ii. Maximum Duration: Three injections per year at the same site when functional benefits are demonstrated with each injection.

e. Return to work with appropriate restrictions should be considered early in the course of treatment. Refer to Return to Work. By 8 to 11 weeks, with restoration of full-motion, return to full-duty should be anticipated.

f. Other therapies in Therapeutic Procedures, Non-operative, may be employed in individual cases.

#### 5. Surgical Indications:

a. Acute Distal Biceps Tendon Rupture: normally requires urgent surgical repair.

b. Acute Proximal Long Head Biceps Tendon Rupture: active patient participation in non-operative treatment is often successful; however, operative intervention may be indicated for young patients, manual laborers or others who require forceful supination regularly for their work.

c. Bicipital Tendonitis: Conservative care prior to potential surgery must address flexibility and strength imbalances. Surgery may be considered when functional deficits interfere with activities of daily living and/or job duties after 12 weeks of active patient participation in non-operative therapy.

d. Subluxing Bicipital Tendon: Most patients with this condition also have a subscapularis tear. Surgical stabilization of the bicipital tendon is not commonly indicated. Good outcome may be achieved through successful rehabilitation procedures. Surgery may be considered when functional deficits interfere with activities of daily living and/or job duties after 12 weeks of active patient participation in non-operative therapy.

e. Prior to surgical intervention, the patient and treating physician should identify functional operative goals and the likelihood of achieving improved ability to perform activities of daily living or work activities and the patient should agree to comply with the pre- and post-operative treatment plan and home exercise requirements. The patient should understand the length of partial and full disability expected post-operatively.

#### 6. Operative Procedures:

a. Distal Biceps tendon repair.

b. Repair of rotator cuff pulley lesion.

c. Proximal tenodesis or tenotomy: Impingement of the biceps tendon can cause continued irritation, and pain preventing shoulder elevation. Tenodesis or tenotomy has been used for decreased elevation after therapy in conjunction with a sub scapular repair or irreparable rotator cuff tear.

#### 7. Post-Operative Treatment:

a. An individualized rehabilitation program based upon communication between the surgeon and the therapist using the treatments found in Therapeutic Procedures, Non-operative. Therapy may include the following:

b. It is reasonable to restrict ROM for two months for tenodesis or distal biceps tendon repair. Early loading of the tendon should be avoided. Surgical patients may not recover sufficiently to perform full activity for 3 to 12 months. Rehabilitation, lasting at least 6 to 12 weeks, is necessary to facilitate Maximum Medical Improvement (MMI).

i. Frequency: Three to five times per week for the first two weeks, three times per week for the following two weeks, then one to two times per week.

ii. Optimum Duration: Six to eight weeks with progression to home exercise and/or pool therapy.

iii. Maximum Duration: 12 weeks. Occasional follow-up visits may be justified to reinforce exercise patterns or to reach final functional goals if the therapy to date has demonstrated objective functional gains.

c. Return to work and restrictions after surgery may be made by an experienced primary occupational medicine physician in consultation with the surgeon or by the surgeon.

C. Brachial Plexus and Shoulder Peripheral Nerve Injuries. Injuries to the brachial plexus and nerves of the shoulder girdle region may result in loss of motor and sensory function, pain, and instability of the shoulder. Signs and symptoms vary with the degree and mechanism of injury. The two modes of injury are: acute direct or indirect traumatic injuries to the shoulder region, and repetitive motion or overuse. Transient compression, stretch or traction (neurapraxia) causes sensory and motor signs lasting days to weeks. Damage to the axon (axonotmesis) without disruption of the nerve framework may cause similar symptoms. The recovery time is delayed and depends upon axon re-growth distally from the site of injury. Laceration or disruption of the entire nerve with complete loss of framework (neurotmesis) is the most severe form of nerve injury and will invariably require surgical intervention. Return of function is dependent upon re-growth of the nerve distal to the injury site. Full return of motor function is variable and may take up to 18 months or longer. Electromyography (EMG) is the most commonly used diagnostic modality to analyze nerve injuries. Electrophysiologic studies, such as electromyography and nerve conduction studies are generally accepted, well-established and widely used for localizing the source of neurological symptoms. These studies should be utilized as an extension of the history and clinical examination and to assess or monitor nerve recovery. Studies should be performed three to four weeks following injury or description of symptoms. Studies performed early may be falsely negative and usually require repeat testing three to four weeks after the original injury. Thus, early testing is not generally recommended. If the symptoms have been present

for longer than three to four weeks, studies may be performed immediately after the initial evaluation. Serial studies may be indicated if initial studies are negative and may also be useful for gauging prognosis. Limb temperature should be controlled at 30 to 40 degrees centigrade. A description of six common nerve injuries to the shoulder girdle and their treatment follow.

1. Brachial Plexus Injuries:

a. Description/Definition:

i. The Brachial Plexus is formed by the nerve roots of C5-C8 and T1. These nerve roots exit the cervical spine and pass through the scalene musculature. After leaving the scalene musculature, at the level of the clavicle, they form trunks, division and chords which ultimately form the peripheral nerves of the arm.

b. Occupational Relationship: Direct injury to brachial plexus results in widespread sensory and motor loss. Direct trauma, subluxation to shoulder, clavicular fractures, shoulder depression, or head deviation away from the arm may result in variable brachial plexus lesions. Weight-lifting and carrying heavy back packs have also been associated with plexus injuries. Most injuries involve the upper and/or lower trunks. Upper trunk plexopathies may accompany full-thickness rotator cuff tears. Isolated middle trunk involvement is rare. Infraclavicular brachial plexus injuries have been reported due to hematoma formation secondary to an axillary block. If this occurs, emergency evacuation of the hematoma may be indicated. Symptoms may appear hours-to-days after the Procedure. Severe motor and sensory axonal loss is frequently seen on electrodiagnostic studies. It is important to differentiate injuries to the brachial plexus from the acquired (non work-related) Parsonage-Turner Syndrome or neuralgic amyotrophy occurring without a history of trauma. This idiopathic syndrome begins with severe pain in the shoulder girdle and is accompanied by resistance to passive motion. As the pain decreases, severe, near total weakness of one or more shoulder girdle muscles occurs. Almost total recovery can be expected but occurs over two to three years.

c. Specific Physical Exam Findings may include:

i. Evidence of trauma or deformity;

ii. Identification of sensory loss and demonstration of weakness which relates to the severity and anatomy of the injury to the brachial plexus; and/or

iii. Pain with recreation of the motions related to the mechanism of injury.

iv. Diagnostic Testing Procedures:

(a). EMG may show acute or chronic denervation of specific nerves. Nerve Conduction Studies demonstrating a loss of amplitude of 50 percent compared to the normal side are considered abnormal. NCVs/EMGs will be repeated at appropriate intervals to assess reinnervation.

(b). If studies do not localize and give sufficient information, then additional information may be obtained

from MRI and/or myelography. These studies are employed to differentiate root avulsion from severe brachial plexus injuries. Occasionally MRI may reveal the presence of an unexpected mass lesion consistent with a tumor.

v. Non-operative Treatment Procedures:

(a). In closed injuries, observation is favored. Repeat electrophysiologic studies may be helpful to assess or monitor recovery.

(b). Rehabilitation is based on procedures set forth Non-operative Treatment Procedures. However, utilization of ultrasound, and cold and heat should be discussed with the primary care physician, since these modalities may aggravate nerve injury.

(c). Medications such as analgesics, nonsteroidal anti-inflammatories, anti-depressants and anti-convulsants are indicated and narcotics may be indicated acutely. All medications should be prescribed as found in Thoracic Outlet Syndrome Guidelines.

(d). Return to work with appropriate restrictions should be considered early in the course of treatment. Refer to Return to Work.

vi. Surgical Indications:

(a). In open injuries, acute exploration may be indicated if nerve discontinuity is visualized. Surgery may be considered post-injury when functional deficits interfere with activities of daily living and/or job duties after active participation in non-operative therapy.

(b). In closed injuries, if functional deficits continue to be documented after three to four months of active patient participation in non-operative therapy, then exploration may be warranted and a surgical consultation should be considered. Patients with progressive weakness or a loss of function post-injury should be referred for surgical consultation immediately.

vii. Operative Procedures.

(a). Exploration and Repair.

viii. Post-Operative Treatment.

(a). An individualized rehabilitation program based upon communication between the surgeon and the therapist. Treatment may include the following:

(b). Early therapeutic rehabilitation interventions are recommended to maintain range-of-motion (ROM) and progressive strengthening.

2. Frequency: Suggested frequency pattern is three to five times per week for the first two weeks. Three times per week for the following two weeks, then one to two times per week. The exact frequency per week will depend on the severity and level of the nerve injury.

3. Optimum Duration: Six to eight weeks with progression to home exercise and/or pool therapy.

4. Maximum Duration: Up to 24 sessions. Additional follow-up visits may be justified to reinforce exercise



patterns or to reach final functional goals if the therapy to date has demonstrated objective functional gains.

a. Return to work and restrictions after surgery may be made by an experienced primary occupational medicine physician in consultation with the surgeon or by the surgeon.

b. Axillary Nerve:

i. Description/Definition: This nerve is derived from the fifth and sixth cervical roots and passes around the shoulder, supplying motor branches to the teres minor and the three heads of the deltoid. The axillary nerve provides sensation to the top of the shoulder at the level of the deltoid.

5. Occupational Relationship: Direct injury and penetrating wounds to the shoulder and upward pressure on the axilla can cause injury to the axillary nerve. Blunt trauma to the anterolateral shoulder has also been reported. Abnormalities of the nerve can be seen with fractures of the surgical neck of the humerus and dislocation of the shoulder. Axillary nerve injury may also occur from shoulder surgery. Patients complain of reduced abduction of overhead strength and/or numbness in the lateral arm. The quadrilateral space syndrome may cause pain in the axillary nerve region with abduction, external rotation, and extension. The axillary nerve and the posterior circumflex artery are in the space bound by the long head of the triceps, the teres minor, subscapularis, and latissimus dorsi when the arm is abducted. This syndrome is most commonly reported in young males 20 to 40 years of age and has been associated with overhead sports.

6. Specific Physical Exam Findings may include:

a. weakness and atrophy of the deltoid muscle and teres minor;

b. strength is lost in abduction, flexion and extension of the shoulder; and/or

c. sensory loss is reported over the upper arm.

7. Diagnostic Testing Procedures.

a. Plain x-rays.

b. EMG and Nerve Conduction Studies three weeks after the injury and repeated at appropriate intervals to assess for reinnervation. Comparison of EMG and NCV findings with the opposite side is usually necessary to diagnose the degree of injury.

c. MRI may be done to rule out other pathology.

d. To confirm quadrilateral space syndrome, an MRI angiogram may be done to visualize the posterior circumflex artery occlusion in abduction. However, occlusion is present in 80 percent of normals also. This study should only be done after conservative therapy and if surgery is being contemplated.

8. Non-Operative Treatment Procedures:

a. Rehabilitation is based on procedures set forth in Non-operative Treatment Procedures. However, utilization of ultrasound, and cold and heat should be discussed with

the primary care physician since these modalities may aggravate the nerve injury. Shoulder range-of-motion should be emphasized. For quadrilateral space syndrome, stretching of the posterior shoulder and teres minor is recommended.

b. Medications such as analgesics, nonsteroidal anti-inflammatory, anti-depressants and anti-convulsants are indicated. Narcotics may be indicated acutely. All medications should be prescribed as described in Thoracic Outlet Syndrome Guidelines.

c. Return to work with appropriate restrictions should be considered early in the course of treatment. Refer to Return to Work.

9. Surgical Indications: Surgical procedures are usually not necessary, since most injuries to the axillary nerve are due to stretch and/or traction and recover within three to six months. Even when deltoid weakness persists, return to full activity can be expected. One may consider surgery when functional deficits interfere with activities of daily living and/or job duties after three to four months of active patient participation in non-operative therapy and with EMG/NCV documentation of ongoing denervation and loss of function. Lesions secondary to direct penetrating trauma or previous surgery may require more immediate intervention. Surgery for quadrilateral space syndrome is not usually necessary as at least 70 percent of patients recover with conservative treatment. Indications may include six months of conservative treatment with persisting functional deficits, a positive arteriogram, and point tenderness at the posterior quadrilateral space. Overall outcomes of surgery cannot be predicted, as only a small case series have been reported.

10. Operative Procedures:

a. Exploration and Repair.

11. Post-Operative Treatment: An individualized rehabilitation program based upon communication between the surgeon and the therapist. Treatment may include the following: Early therapeutic rehabilitation interventions are recommended to maintain range-of-motion (ROM) and progressive strengthening.

a. Frequency: Suggested frequency pattern is three to five times per week for the first two weeks. Three times per week for the following two weeks, then one to two times per week. The exact frequency per week will depend on the severity and level of the nerve injury.

b. Optimum Duration: Six to eight weeks with progression to home exercise and/or pool therapy.

c. Maximum Duration: Up to 24 sessions. Additional follow-up visits may be justified to reinforce exercise patterns or to reach final functional goals if the therapy to date has demonstrated objective functional gains.

d. Return to work and restrictions after surgery may be made by an experienced primary occupational medicine physician in consultation with the surgeon or by the surgeon.

e. Long Thoracic Nerve.

12. Description/Definition:

a. The long thoracic nerve is formed by the cervical fifth, sixth, and seventh roots; it crosses the border of the first rib and descends along the posterior surface of the thoracic wall to the serratus anterior.

13. Occupational Relationship:

a. Injury can occur by direct trauma to the posterior triangle of the neck or trauma may be the result of chronically repeated or forceful shoulder depression. Repeated forward, overhead motion of the arms with the head tilted or rotated to the unaffected side, as well as, stretch or compression of the nerve with the arms abducted, can lead to long thoracic nerve dysfunction. Occasionally, severe traction with the shoulder compressed and the head tilted may be associated with long thoracic nerve pathology.

14. Specific Physical Exam Findings may include:

a. dull ache in the region of the shoulder exacerbated by tilting the head away from the effected side and without sensory loss;

b. scapular deformity and/or winging may be described by patient or family; and/or

c. serratus anterior wasting; and

d. scapular winging at the inferior border that may be demonstrated by asking the patient to forward elevate and lean on his arms, such as against a wall and/or the examiner resisting protraction. (Spinal accessory nerve pathology also causes winging when the patient is abducting.)

15. Diagnostic Testing Procedures.

a. Plain x-rays.

b. EMG and Nerve Conduction Studies three weeks after the injury and repeated at appropriate intervals to assess for reinnervation. Comparison of EMG and NCV findings with the opposite side is usually necessary to diagnose the degree of injury. Studies may also exclude more widespread brachial involvement.

c. MRIs or CTs if there is a need to rule out other pathology.

16. Non-Operative Treatment Procedures.

a. Rehabilitation is based on procedures set forth in Non-operative Treatment Procedures. Utilization of ultrasound, cold, and heat should be discussed with the Primary Care Physician since these modalities can aggravate nerve injury. Strengthening of the scapular stabilizers should be stressed.

b. Orthotics may be used to stabilize the scapula but long-term benefit is not established.

c. Medications such as analgesics, nonsteroidal anti-inflammatory, anti-depressants and anti-convulsants are indicated and narcotics may be indicated acutely. All medications should be prescribed as seen in Thoracic Outlet Syndrome Guidelines.

d. Return to work with appropriate restrictions should be considered early in the course of treatment (Refer to Return to Work). Heavy lifting and other activities that might stress the nerve should be avoided.

17. Surgical Indications. Laceration of the nerve and progressive loss of function are indications for prompt surgical intervention. Surgery may be considered when functional deficits interfere with activities of daily living and/or job duties after four to six months of active participation in non-operative therapy. Surgical consultation should occur at three to four months post-injury for these patients. In most cases, function will recover with conservative therapy in 6 to 12 months.

18. Operative Procedures:

a. exploration and repair;

b. muscle transfer;

c. scapular fixation.

19. Post-Operative Treatment: An individualized rehabilitation program based upon communication between the surgeon and the therapist. Treatment may include the following: Early therapeutic rehabilitation interventions are recommended to maintain ROM with progressive strengthening focusing on the scapular stabilizers.

a. Frequency: Suggested frequency pattern is three to five times per week for the first two weeks. Three times per week for the following two weeks, then one to two times per week. The exact frequency per week will depend on the severity and level of the nerve injury.

b. Optimum Duration: Six to eight weeks with progression to home exercise and/or pool therapy.

c. Maximum Duration: Up to 24 sessions. Additional follow-up visits may be justified to reinforce exercise patterns or to reach final functional goals if the therapy to date has demonstrated objective functional gains.

d. Return to work and restrictions after surgery may be made by an experienced primary occupational medicine physician in consultation with the surgeon or by the surgeon.

e. Musculocutaneous Nerve.

D. Description/Definition: The nerve is derived from the fifth and sixth cervical roots. It innervates the coracobrachialis, biceps and brachioradialis muscles and also provides sensation to the lateral aspect of the forearm.

E. Occupational Relationship: Trauma (including surgery) or penetrating wound to the brachial plexus, coracobrachialis, and shoulder often can cause nerve injury. Most commonly, a stretch/traction injury with the arm in abduction and external rotation induces nerve dysfunction. Cases have been reported to be associated with backpack use, pitching, heavy weight-lifting, mal-position during sleep or surgery, and sudden, forceful extension of the elbow. Complaints may include pain from the axilla into the forearm, biceps weakness, or sensation changes to the lateral forearm from the lateral antebrachial cutaneous nerve.

1. Specific Physical Exam Findings may include:
  - a. weakness and atrophy in the biceps and brachialis; and/or
  - b. sensory loss over the lateral aspect of the forearm; however, this is not always seen.
2. Diagnostic Testing Procedures.
  - a. EMG and Nerve Conduction Studies three weeks after the injury and repeated at appropriate intervals to assess for reinnervation. Comparison of EMG and NCV findings with the opposite side is usually necessary to diagnose the degree of injury.
3. Non-operative Treatment Procedures.
  - a. Rehabilitation is based on procedures set forth in Non-operative Treatment Procedures. Utilization of ultrasound, cold and heat should be discussed with the primary care physician, since these modalities can aggravate nerve injury.
  - b. Medications such as analgesics, nonsteroidal anti-inflammatory, anti-depressants and anti-convulsants are indicated and narcotics may be indicated acutely. All medications should be prescribed as seen in Thoracic Outlet Syndrome Guidelines.
  - c. Return to work with appropriate restrictions should be considered early in the course of treatment. Refer to Return to Work.
4. Surgical Indications: Laceration of the nerve and progressive loss of function are indications for prompt surgical intervention. Surgery may be considered when functional deficits interfere with activities of daily living and/or job duties after four to six months of active patient participation in non-operative therapy. Surgical consultation should occur at three to four months post-injury for these patients. In most cases, function will recover with conservative therapy in 6 to 12 months.
5. Operative Procedures.
  - a. Exploration and Repair.
6. Post-Operative Treatment: An individualized rehabilitation program based upon communication between the surgeon and the therapist. Treatment may include the following: Early therapeutic rehabilitation interventions are recommended to maintain ROM with progressive strengthening.
  - a. Frequency: Suggested frequency pattern is three to five times per week for the first two weeks. Three times per week for the following two weeks, then one to two times per week. The exact frequency per week will depend on the severity and level of the nerve injury.
  - b. Optimum Duration: Six to eight weeks with progression to home exercise and/or pool therapy.
  - c. Maximum Duration: Up to 24 sessions. Additional follow-up visits may be justified to reinforce

exercise patterns or to reach final functional goals if the therapy to date has demonstrated objective functional gains.

d. Return to work and restrictions after surgery may be made by an experienced primary occupational medicine physician in consultation with the surgeon or by the surgeon.

e. Spinal Accessory Nerve:

i. Description/Definition: Spinal Accessory Nerve is the eleventh cranial nerve innervating the ipsilateral sternocleidomastoid and trapezius muscles which are extremely important for scapular control and ultimately shoulder function.

ii. Occupational Relationship: Direct trauma to the posterior neck, forceful compression of the shoulder downward, and/or deviation of the head away from the traumatized shoulder can lead to injury to this nerve such as from a fall or motor vehicle accident. Surgical resection of the posterior neck can disrupt the nerve. Patients complain of inability to fully elevate or abduct above horizontal.

7. Specific Physical Exam Findings may include:

- a. pain in the shoulder;
- b. asymmetrical neckline;
- c. scapular winging with the arms out to the side, abduction, or with external rotation;
- d. weakness or paralysis of the trapezius with weakness in forward flexion or abduction above 90 degrees; and/or
- e. drooping of the shoulder.

8. diagnostic Testing Procedures:

a. EMG and Nerve Conduction Studies three weeks after the injury and repeated at appropriate intervals to assess for reinnervation. Comparison of EMG and NCV findings with the opposite side is usually necessary to diagnose the degree of injury.

b. Radiographic procedures may be necessary to exclude lesions at the base of the brain or upper cervical spine.

9. Non-operative Treatment Procedures.

a. Rehabilitation is based on procedures set forth in Non-Operative Treatment Procedures. Utilization of ultrasound, cold and heat should be discussed with the Primary Care Physician, since these modalities can aggravate nerve injury. Resistance exercises to strengthen muscles. Braces may be used but probably have no long-term value.

b. Occupational work station will usually need significant modification due to inability to work above 90 degrees flexion or abduction. Return to work with appropriate restrictions should be considered early in the course of treatment. Refer to Return to Work.

c. Medications such as analgesics, nonsteroidal anti-inflammatory, anti-depressants and anti-convulsants are

indicated and narcotics may be indicated acutely. All medications should be prescribed as seen in Thoracic Outlet Syndrome Guidelines.

10. Surgical Indications: Laceration of the nerve and progressive loss of function are indications for prompt surgical intervention. Surgery may be considered when functional deficits interfere with activities of daily living and/or job duties after four to six months of active participation in non-operative therapy. Surgical consultation should occur at three to four months post-injury for these patients. In most cases, function will recover with conservative therapy in 6 to 12 months.

#### 11 Operative Procedures.

- a. exploration and repair;
- b. tendon transfer—trapezius, levator scapular, rhomboids;
- c. scapular fixation for cases with heavy work demands and failed previous procedures.

12. Post-Operative Treatment: An individualized rehabilitation program based upon communication between the surgeon and the therapist. Treatment may include the following:

- a. Early therapeutic rehabilitation interventions are recommended to maintain ROM with progressive strengthening focusing on scapula stabilizers.
  - i. Frequency: Suggested frequency pattern is three to five times per week for the first two weeks. Three times per week for the following two weeks, then one to two times per week. The exact frequency per week will depend on the severity and level of the nerve injury.
  - ii. Optimum Duration: Six to eight weeks with progression to home exercise and/or pool therapy.
  - iii. Maximum Duration: Up to 24 sessions. Additional follow-up visits may be justified to reinforce exercise patterns or to reach final functional goals if the therapy to date has demonstrated objective functional gains.
  - iv. Return to work and restrictions after surgery may be made by an experienced primary occupational medicine physician in consultation with the surgeon or by the surgeon.
  - vi. Suprascapular Nerve.

(a). Description/Definition. This nerve is derived from the fifth and sixth cervical root, superior trunk of the brachial plexus and it innervates the supraspinatus and infraspinatus muscles of the rotator cuff.

(b). Occupational Relationship. Supraclavicular trauma, stretch, and friction through the suprascapular notch or against the transverse ligament at the notch, or a fall on an outstretched arms can cause injury to the nerve. Repetitive use of the arm has been shown on occasion to cause traction to the nerve. Damage, may occur secondary to a ganglion cyst which usually causes infraspinatus atrophy. Ganglion cysts may be associated with labral pathology and/or rotator

cuff tears. These are most commonly reported in athletes. Up to one third of volley ball players in one study had asymptomatic infraspinatus atrophy secondary to nerve damage. Nerve damage may also occur associated with a full rotator cuff tear. Since the clinical findings are similar for both diagnoses, clinicians should always consider the possibility of nerve damage when atrophy accompanies a rotator cuff tear.

(c). Specific Physical Exam Findings may include:

- (i). pain at the shoulder;
- (ii). wasting at the supraspinatus and/or infraspinatus muscles with weakness of external rotation and abduction with overhead activity; and/or
- (iii).a positive Tinel's eliciting a provocative pain response.

#### (d). Diagnostic Testing Procedures:

(i). EMG and Nerve Conduction Studies three weeks after the injury and repeated at appropriate intervals to assess for reinnervation. Comparison of EMG and NCV findings with the opposite side is usually necessary to diagnose the degree of injury.

(ii). If one suspects a mass lesion at the suprascapular notch or related labral or cuff pathology then an MRI or sonography may be indicated.

(iii).CT scan with attention to the suprascapular notch may be used to evaluate for boney impingement.

#### (e). Non-operative Treatment Procedures:

(i). Resolution of symptoms usually occurs within 6 to 12 months of diagnosis with non-operative treatment in the absence of lesions such as a cyst.

(ii). Rehabilitation is based on procedures set forth in Non-operative Treatment Procedures. An emphasis should be placed on posture; maintaining full shoulder motion; strengthening; and stretching the posterior capsule. Utilization of ultrasound, cold and heat should be discussed with the primary care physician, since these modalities can aggravate nerve injury.

(iii).Medications such as analgesics, nonsteroidal anti-inflammatory, anti-depressants, and anti-convulsants are indicated and narcotics may be indicated acutely. All medications should be prescribed as seen in Thoracic Outlet Syndrome Guidelines.

(iv).Return to work with appropriate restrictions should be considered early in the course of treatment (Refer to Return to Work). Heavy lifting or activities that aggravate the condition should be avoided.

13. Surgical Indications: Surgical release is warranted depending upon the presence of a ganglion cyst, results of the electrophysiologic studies, and/or absence of improvement with conservative management. In cases without cysts or other operative diagnoses, non-operative

treatment may be tried for three to six months due to the observed recovery rate of cases with no treatment. Difficulty performing functional activities after active patient participation should be the deciding factor. [General Principles]

#### 14. Operative Treatment Procedures.

- a. decompression and/or excision of ganglion cyst; and/or labral repair;
- b. surgical release at the suprascapular notch or spinoglenoid region;

15. Post-Operative Treatment: An individualized rehabilitation program based upon communication between the surgeon and the therapist using the treatments found in Therapeutic Procedures, Non-operative. Treatment may include the following: Early therapeutic rehabilitation interventions are recommended to maintain ROM with progressive strengthening.

a. Frequency: Suggested frequency pattern is three to five times per week for the first two weeks. Three times per week for the following two weeks, then one to two times per week. The exact frequency per week will depend on the severity and level of the nerve injury.

b. Optimum Duration: Six to eight weeks with progression to home exercise and/or pool therapy.

c. Maximum Duration: Up to 24 sessions. Additional follow-up visits may be justified to reinforce exercise patterns or to reach final functional goals if the therapy to date has demonstrated objective functional gains.

d. Return to work and restrictions after surgery may be made by an experienced primary occupational medicine physician in consultation with the surgeon or by the surgeon.

#### F. Bursitis/Rotator Cuff Tendonopathy (Alternate Spelling "Tendinopathy") of the Shoulder

##### 1. Description/Definition.

a. Bursitis: Acute or chronic inflammation of the bursa (a potential fluid filled sac) that may be caused by trauma, chronic overuse, inflammatory arthritis, and acute or chronic infection, and generally presents with localized pain and tenderness of the shoulder.

b. Tendonopathy includes the terms tendonitis, an inflammation of the tendon and tendonosis, non-inflammatory degenerative processes.

c. Rotator cuff tendonopathy may involve one or more of the four musculotendinous structures arising from the scapula and inserting on the lesser or greater tuberosity of the humerus may be involved. These structures include one internal rotator (subscapularis), and two external rotators (infraspinatus and teres minor), and the supraspinatus which assists in abduction.

d. History may include nocturnal pain, pain with over-the-shoulder activities, feeling of shoulder weakness and specific limitations of movement. Prior treatment for

presenting complaint(s) and pertinent familial history should be obtained.

2. Occupational Relationship: Onset of symptoms, date, mechanism of onset, and occupational history and current job requirements should be correlated with the intensity, character, duration and frequency of associated pain and discomfort. Tendonopathy may include symptoms of pain and/or achiness that occur after blunt trauma or repetitive use of the shoulder. Bursitis is often a sequela of an occupational strain or tendonopathy in the absence of other mitigating factors.

##### 3. Specific Physical Exam Findings may include:

a. Palpation elicits localized tenderness over the particular bursa or inflamed tendon with loss of motion during activity;

b. Painful arc may be seen between 40 and 120 degrees; and/or

c. Bursitis may be associated with other shoulder injury diagnoses such as impingement, rotator cuff instability, tendonitis, etc.; refer to applicable diagnosis subsections for additional guidelines.

##### 4. Diagnostic Testing Procedures:

a. Plain x-rays include:

5. AP view. Elevation of the humeral head indicates rotator cuff tear;

6. Lateral view in the plane of the scapula or an axillary view determines if there is anterior or posterior dislocation, or the presence of a defect in the humeral head (a Hill-Sachs lesion);

7. Axillary view is also useful to demonstrate arthritis and spurs on the anterior inferior acromion;

8. Outlet view determines if there is a downwardly tipped acromion.

a. Lab Tests. Laboratory tests may be used to rule out systemic illness or disease when proper clinical presentation indicates the necessity for such testing. Testing may include sedimentation rate, rheumatoid profile, complete blood count (CBC) with differential, and serum uric acid level. Routine screening for other medical disorders may be necessary, as well as, bursal aspiration with fluid analysis.

b. The subacromial injection has generally been considered the gold standard for differentiating ROM loss from impingement versus rotator cuff tears. Alleviation from pain may help to confirm the diagnosis. Patients with impingement should recover normal strength after the injection, while those with rotator cuff tears usually do not recover normal strength. However, manually tested elevation strength perceived as normal does not always rule out rotator cuff tear and this may contribute to incorrect diagnoses with this technique. There is good evidence that blinded subacromial blocks are not accurate. Up to a third of blinded injections may involve the cuff, and are likely to cause pain.

This may lead to an incorrect diagnosis. One study demonstrated that at least half of the positive responders did so up to 40 minutes after the injection; therefore, a negative response should not be diagnosed until 40 minutes post injection. The inaccuracy of the injection and patient response in some cases may contribute to its inability to completely predict the amount of recovery from subacromial decompression.

c. If there is a concern regarding needle placement, sonography or fluoroscopy may be used.

d. Steroid injections should be used cautiously in diabetic patients. Diabetic patients should be reminded to check their blood glucose level at least daily for two weeks after injections.

#### 9. Non-operative Treatment Procedures:

a. Therapeutic interventions are the mainstay of treatment. They should include ROM, active therapies, and a home exercise program. Passive as well as active therapies may be used for control of pain and swelling. Therapy should progress to strengthening and instruction in a home exercise program targeted to further improve ROM and strength of shoulder girdle musculature. Refer to Therapeutic Procedures, Non-operative.

b. May return to work without overhead activities and lifting with involved arm. An evaluation of the occupational work being performed and the work station may be necessary to institute ergonomic changes or accommodations. Return to work with appropriate restrictions should be considered early in the course of treatment. Refer to Return to Work.

c. Medications such as oral nonsteroidal anti-inflammatory, oral steroids and analgesics.

d. Steroid injections may be therapeutic. Injections under significant pressure should be avoided as the needle may be penetrating the tendon and injection into the tendon can cause possible tendon breakdown, tendon degeneration, or rupture. Injections should be minimized for patients under 30 years of age.

i. Time to Produce Effect: One injection.

ii. Maximum: three injections at the same site per year when functional benefits are demonstrated with each injection.

iii. Steroid injections should be used cautiously in diabetic patients. Diabetic patients should be reminded to check their blood glucose level at least daily for two weeks after injections.

e. Other therapies outlined in Therapeutic Procedures, Non-operative, may be employed in individual cases.

10. Operative Procedures: Are not commonly indicated for bursitis or tendonopathy. Refer to other related diagnoses in Specific Diagnosis Testing and Treatment Procedures.

#### 11. Calcifying Tendodnitis

##### a. Description/Definition:

i. Calcifying tendonitis is characterized by the deposition of hydroxyapatite (calcium phosphate) in any tendon of the rotator cuff. The supraspinatus tendon is affected most frequently. It is a morphologic diagnosis which may be asymptomatic or may produce pain. It may be present in a painful shoulder without being the cause of the pain. Radiographically evident calcifications are present without producing symptoms in some adults (7.5 percent to 20 percent). The calcifying process occurs in two phases: the formative phase, in which calcium deposits coalesce in the tendon matrix, and the resorptive phase, in which the calcium deposits are removed by phagocytic cells. The resorptive phase is thought to be the painful phase of the disorder. The etiology is not known, but trauma is considered unlikely to be causative. Pain may be accompanied by loss of ROM, a painful arc of motion, or by impingement signs. Morphologic classification of calcium deposits is based on the homogeneity and borders of the deposit on plain x-ray. (Gartner and Simons Classifications) Type I is homogenous with well-defined borders. Type II is heterogeneous in structure with sharp outline or homogenous in structure with no defined border. Type III is cloudy and transparent with no well-defined border. Type III frequently resolves without treatment. Generally, they are not associated with rotator cuff tears. The size of the deposit has not been shown to be correlated with severity of symptoms.

b. Occupational Relationship. Symptomatic calcifying tendonitis may occur after repetitive loading of the shoulder with force, such as with shoveling, raking, pushing, pulling, lifting at/or above shoulder level, or after blunt trauma to the shoulder.

##### c. Specific Physical Exam Findings may include:

i. pain with palpation to the shoulder with active or passive abduction and external rotation of the shoulder (painful arc);

ii. pain with specific activation of the involved muscles; and/or

iii. pain with impingement signs;

iv. severe pain on examination in some cases.

##### d. Diagnostic Testing Procedures:

i. plain x-ray films including AP lateral, axial, 30 degrees caudally angulated AP, Outlet view.

ii. If shoulder pain is refractory to 4 to 6 weeks of non-operative care and other diagnoses are suspected, adjunctive testing, such as MRI, sonography or arthrography, may be indicated.

##### e. Non-operative Treatment Procedures

i. Therapeutic rehabilitation interventions are the mainstay of treatment. They should include ROM, active therapies, and a home exercise program. Passive as well as active therapies may be used for pain control, including iontophoresis. Therapy should progress to strengthening and instruction in a home exercise programs targeted to ongoing

ROM and strengthening of shoulder girdle musculature. Refer to Therapeutic Procedures, Non-operative for other therapies as well as a description of active and passive therapies.

ii. Medications such as oral nonsteroidal anti-inflammatories, analgesics, and narcotics for significant pain. Refer to Medications.

iii. May return to work without overhead activities and lifting with involved arm. An evaluation of the occupational work station may be necessary to institute ergonomic changes or accommodations. Return to work with appropriate restrictions should be considered early in the course of treatment. Refer to Return to Work.

iv. Therapeutic ultrasound (Refer to Passive Therapy) may be used for tendonitis. There is some evidence that ultrasound alleviates symptoms, improves function, and reduces calcium deposits better than sham ultrasound in the short term. The advantage of ultrasound beyond six weeks is not certain.

v. Ultrasound-guided needle lavage and aspiration requires a physician skilled in sonographic techniques and is still considered investigational due to lack of randomized controlled trials. It is less costly and reportedly less painful than extracorporeal shock wave therapy. It requires prior authorization but may be an appropriate therapy in select patients who fail other conservative treatment.

vi. Extracorporeal shock wave therapy has good evidence for improving pain and function with calcifying tendonitis Type I or II when conservative treatment has not resulted in adequate functional improvement (See ESWT). General anesthesia or conscious sedation is not required for this procedure. Patients should be cautioned regarding the potential of avascular necrosis.

vii. Steroid injections may be therapeutic. Injections under significant pressure should be avoided as the needle may be penetrating the tendon and injection into the tendon can cause tendon degeneration, tendon breakdown, or rupture. Injections should be minimized for patients under 30 years of age.

(a). Steroid injections should be used cautiously in diabetic patients. Diabetic patients should be reminded to check their blood glucose level at least daily for two weeks after injections.

(i). Time to Produce Effect: One injection.

(ii). Maximum: Three injections at the same site per year when functional benefits are demonstrated with each injection.

viii. Other therapies outlined in Therapeutic Procedures, Non-operative, may be employed in individual cases.

f. Surgical Indications. When functional deficits interfere with activities of daily living and/or job duties after three to four months of active patient participation in non-

operative therapy. The natural history of calcifications includes resorption over time, with or without therapy. Prior to surgical intervention, the patient and treating physician should identify functional operative goals and the likelihood of achieving improved ability to perform activities of daily living or work activities. The patient should agree to comply with the pre- and post-operative treatment plan and home exercise requirements. The patient should understand the length of partial and full disability expected post-operatively.

g. Operative Procedures: Either an arthroscopic or open procedure may be used. Careful lavage to remove all calcium deposits from the surgical field is important. Full recovery may vary from three to six months.

h. Post-Operative Treatment. Individualized rehabilitation programs are based upon communication between the surgeon and the therapist using the treatments found in Therapeutic Procedures, Non-operative. Treatment may include the following:

i. sling, pillow sling, or abduction splint;

ii. gentle pendulum exercise, passive glenohumeral range-of-motion and posterior scapular stabilizing training can be instituted;

iii. patients can judiciously return to activities as tolerated per physician recommendations. If there is a significant tendon repair, progression will be delayed;

iv. progressive resistive exercise program beginning at two months with gradual returning to full activity at 4 to 6 months; all active non-operative procedures listed in Non-operative Treatment Procedures should be considered.

(a). Frequency: Three to five times per week for the first two weeks, three times per week for the following two weeks, then one to two times per week.

(b). Optimum Duration: Six to eight weeks with progression to home exercise and/or pool therapy.

(c). Maximum Duration: 12 weeks. Occasional follow-up visits may be justified to reinforce exercise patterns or to reach final functional goals if the therapy to date has demonstrated objective functional gains.

v. Return to work and restrictions after surgery may be made by an experienced primary occupational medicine physician in consultation with the surgeon or by the surgeon. Depending upon the patient's functional response and their job requirements, return to work with job modifications may be considered as early as one week post-operatively. The employer must be able to fully accommodate restrictions of overhead activities or heavy lifting. Physician/surgeon should be very specific regarding restrictions for overhead activities and heavy lifting. Work restrictions should be evaluated every four to six weeks during post-operative recovery and rehabilitation, with appropriate written communications to both the patient and the employer. Should progress plateau, the provider should re-evaluate the patient's condition and make appropriate adjustments to the treatment plan.

12. Fractures. There are five common types of shoulder fractures; each type will be addressed separately and in the order of most frequent occurrence.

a. Clavicular Fracture:

i. Occupational Relationship: Can result from direct blows or axial loads applied to the upper limb; commonly associated injuries include rib fractures, long-bone fractures of the ipsilateral limb and scapulothoracic dislocations.

ii. Specific Physical Exam Findings may include:

- (a). pain along the clavicle;
- (b). abrasions on the chest wall, clavicle and shoulder;
- (c). deformities in the above regions; and/or
- (d). pain with palpation and motion at the shoulder joint area.

iii. Diagnostic Testing Procedures: Clavicle x-rays. If they do not reveal sufficient information, then a 20 degree caudal-cranial AP view centered over both clavicles can be done.

iv. Non-operative Treatment Procedures:

(a). Most are adequately managed by closed techniques and do not require surgery. After reduction, the arm is immobilized in a sling or figure-8 bandage. Shoulder rehabilitation is begun with pendulum exercises 10 to 14 days after injury. Subsequently, with pain control, the therapy program can be progressed with therapeutic approaches as indicated in Non-operative Treatment Procedures.

(b). Medication, such as analgesics and nonsteroidal anti-inflammatories, would be indicated; narcotics may be indicated acutely for fractures and should be prescribed as indicated in Medications.

(c). All patients with fractures, especially those over 50, should be encouraged to ingest at least 1200 mg of Calcium and 800 IU of Vitamin D per day. There is some evidence that, for women in the older age group (58 to 88) with low hip bone density, greater callus forms for those who adhere to these recommendations than those who do not. Although the clinical implications of this are not known, there is greater non-union in this age group and thus, coverage for these medications during the fracture healing time period is recommended. At this time there is no evidence that bisphosphonates increase acute fracture healing.

(d). All female patients over 65 should be referred for an osteoporosis evaluation. Patients who have been on prednisone at a dose of 5 to 7.5 mg for more than three months should be evaluated for glucocorticoid induced osteoporosis. An osteoporosis evaluation may be considered for males who: are over 70, are physically inactive, have previous fragility fracture, have a BMI less than 20, or have been hypogonadal for five years. Evaluation may also be

considered for patients on medications that can cause bone loss, patients who have suffered a fracture due to a low-impact fall or with minimum to no provocation, and women under 65 with one of the following: menopause before 40, current smoker, or body mass index less than 20. Low body weight appears to be the best predictor of osteoporosis in women younger than 65. In one adequate study, all patients aged 50 to 75 referred to an orthopaedic department for treatment of wrist, vertebral, proximal humerus, or hip fractures received bone mass density testing. 97 percent of patients had either osteoporosis (45 percent) or osteopenia (42 percent). Referral is important to prevent future fractures in these groups. Long-term care for osteoporosis is not covered under workers compensation even though it may be discovered due to an injury-related acute fracture.

(e). Smoking may affect fracture healing. Patients should be strongly encouraged to stop smoking and provided with appropriate counseling.

(f). Return to work with appropriate restrictions should be considered early in the course of treatment. Refer to Return to Work.

v. Surgical Indications: Open fractures, vascular or neural injuries requiring repair, bilateral fractures, ipsilateral scapular or glenoid neck fractures, scapulothoracic dislocations, flail chest and non-union (displaced-closed fractures that show no evidence of union after four to six months). A Type II fracture/dislocation at the AC joint where the distal clavicular fragment remains with the acromion and the coracoid, and the large proximal fragment is displaced upwards is another indication for surgery. Completely displaced midclavicular fractures may be an indication for surgical repair. There is some evidence that plate fixation of completely displaced fractures involving the middle third of the clavicle leads to slightly better shoulder function than immobilization without surgical fixation and shorter healing time. Conservatively treated completely displaced fractures heal with mild decreases in strength and good patient satisfaction in 70 percent or more of cases. However, initial surgical repair may be considered for patients who desire excellent shoulder function for sport or job activities and/or those with approximately two cm or greater shortening of the clavicle. Because smokers have a higher risk of non-union and post-operative costs, it is recommended that insurers cover a smoking cessation program peri-operatively.

vi. Operative Procedures: Repair of fracture or associated distal clavicular resection using plates and screws or an intramedullary device.

vii. Post-Operative Treatment: An individualized rehabilitation program based upon communication between the surgeon and the therapist. This program would begin with two to three weeks of rest with a shoulder immobilizer while encouraging isometric deltoid strengthening. Pendulum exercises with progression to assisted forward flexion and external rotation would follow. Strengthening exercises should be started at 10 to 12 weeks as indicated in Non-operative Treatment Procedures.



## viii. Bone-Growth Stimulators

(a). Electrical: Preclinical and experimental literature has shown a stimulatory effect of externally applied electrical fields on the proliferation and calcification of osteoblasts and periosteal cells. Ensuing clinical literature on electrical stimulation of bone fractures has principally focused on the spine and lower extremity. Several techniques have been developed to deliver an electrical stimulus to a fracture or osteotomy site. Nonsurgical techniques include Capacitive Coupling (CC), which places skin electrodes on opposite sides of the bone being treated. Pulsed Electromagnetic Field (PEMF) uses a current-carrying coil which induces a secondary electrical field in bone. High-quality literature of electrical bone growth stimulation are lacking for shoulder injuries. Literature is conflicting in the use of electrical stimulation in other regions of the body. Due to a lack of supporting scientific evidence, it requires prior authorization and may be only considered when conventional surgical management has failed.

(b). Low-intensity Pulsed Ultrasound: There is some evidence that low-intensity pulsed ultrasound, applied by the patient at home and administered as initial treatment of the fracture, reduces the time required for cortical bridging in certain fractures of bones outside the shoulder joint. Shoulder fractures were not included in this literature. Non-union and delayed unions were not included in these clinical trials. Possible indications for Low-Intensity Pulsed Ultrasound are non-unions or fractures that are expected to require longer healing time. Prior authorization is required.

b. Proximal Humeral Fractures: Fractures of the humeral head have been classically described using Neer criteria; however, literature has shown a low level of observer agreement. These fractures are commonly referred to as one, two, three or four part fractures based on the number of fracture fragments. Displaced fractures of the greater tuberosity and impacted angulated fractures of the humeral head also have specific associated problems.

i. Occupational Relationship: May be caused by a fall onto an abducted arm; high-energy (velocity or crush) trauma with an abducted or non-abducted arm. Associated injuries are common, such as glenohumeral dislocation; stretch injuries to the axillary, musculocutaneous, and radial nerves; and axillary artery injuries with high-energy accident.

## ii. Specific Physical Exam Findings may include:

- (a). pain in the upper arm;
- (b). swelling and bruising in the upper arm, shoulder and chest wall;
- (c). abrasions about the shoulder; and/or
- (d). pain with any attempted passive or active shoulder motion.

## iii. Diagnostic Testing Procedures:

(a). X-ray trauma series (three views) are needed; AP view, axillary view and a lateral view in the

plane of the scapula. The latter two views are needed to determine if there is a glenohumeral dislocation. When an axillary view cannot be obtained, a CT should be done to rule out posterior dislocation.

(b). Vascular studies are obtained emergently if the radial and brachial pulses are absent.

(c). Classification can be by the Neer Method, however, agreement between observers using this method is poor. There are four fragments: the humeral shaft, humeral head, greater tuberosity, and the lesser tuberosity. The fragments are not usually considered fragments unless they are separated by 1 cm or are angulated 45 degrees or more.

## iv. Non-operative Treatment Procedures

(a). Non-displaced and minimally displaced fractures are generally treated conservatively with broad arm sling or body swath. There is some evidence that simple non-displaced proximal humeral fractures recover normal function more quickly when physical therapy is started one week after the fracture than when it is started three weeks after the fracture. Immobilization without physical therapy for more than one week is not recommended.

(b). Anterior or posterior dislocation associated with minimally displaced fractures can usually be reduced by closed means, but a general anesthetic is needed. These are usually not performed in the emergency room in order to avoid displacement of the fracture.

(c). Medication, such as analgesics and nonsteroidal anti-inflammatories, would be indicated; narcotics may be indicated acutely for fracture and should be prescribed as indicated in Medications.

(d). Immobilization may be provided with a sling, to support the elbow, or with an abduction immobilizer if a non-impacted greater tuberosity fragment is present. Immobilization is usually continued for four to ix weeks; however, the time will vary according to the type of fracture and surgeon's discretion.

(e). Shoulder rehabilitation is begun with pendulum exercises 0 to 14 days after injury. Light, functional exercises may be added at two to four weeks post-injury. Subsequently, with pain control, the therapy program can be progressed with therapeutic approaches as described in Non-operative Treatment Procedures. Home exercises are essential for recovery.

(i). Time to Produce Effect: Six sessions.

(ii). Optimum Duration: Nine sessions.

(iii). Maximum Duration: 12 to 24 sessions.

(f). Use of the injured arm at work is determined by the orthopaedist. The patient may, however, return to work without use of the injured arm soon after the injury. Refer to Return to Work.

(g). Also refer to osteoporosis in this Clavicular Fracture.

(h). Smoking may affect fracture healing. Patients should be strongly encouraged to stop smoking and provided with appropriate counseling.

v. Surgical Indications:

(a). Greater tuberosity fractures with 5mm of displacement usually require surgical fixation. However, rehabilitation may start as early as two to three days post-operatively.

(b). Two-part fractures are repaired according to the surgeon's preference. Internal fixation may be necessary to prevent varus or valgus angulation of the humerus; however, it is unclear whether this technique is more successful than more conservative treatment particularly in patients over 70. Percutaneous techniques and closed reduction have both been used.

(c). Three and four-part fractures frequently require operative treatment. Internal fixation is commonly used. Hemiarthroplasty may be used in the elderly population or for severely comminuted fractures. Use of this technique in the younger active patients frequently leads to the need for revision surgery and/or increased wear of the glenoid cavity. For four-part fractures with a fractured greater tuberosity, reverse arthroplasties have also been described, however; they should rarely be used since the long-term success of this prosthesis is currently unknown. This procedure is described under Section G. Therapeutic Procedures, Operative Shoulder Replacement (arthroplasty).

(i). Because smokers have a higher risk of non-union and post-operative costs, it is recommended that carriers cover a smoking cessation program peri-operatively.

vi. Operative Procedures: Percutaneous or internal fixation of the fracture or arthroplasty.

vii. Post-Operative Treatment

(a). An individualized rehabilitation program based upon communication between the surgeon and the therapist using the treatment found in Section F.

(b). Schanz pins will require removal, frequently between Two to six weeks.

(c). One-time Extracorporeal Shock Wave Therapy (ESWT) has been purported to increase healing in non-union fractures of long bones. None have been tested in prospective controlled studies. They are all considered experimental and are not recommended at this time.

(d). Bone-Growth Stimulators. (Refer to Clavicular Fractures.)

(e). Hyperbaric oxygen therapy – there is no evidence to support long-term benefit of hyperbaric oxygen therapy for non-union upper extremity fractures. It is not recommended.

(f). Return to work and restrictions after surgery may be made by an experienced primary occupational medicine physician in consultation with the surgeon or by the surgeon.

c. Humeral Shaft Fractures:

i. Occupational Relationship: A direct blow can fracture the humeral shaft at the junction of its middle and distal thirds. Twisting injuries to the arm will cause a spiral humeral shaft fracture. High energy (velocity or crush) will cause a comminuted humeral shaft fracture.

ii. Specific Physical Exam Findings may include:

(a). deformity of the arm;

(b). bruising and swelling; and/or

(c). possible sensory and/or motor dysfunction of the radial nerve.

iii. Diagnostic Testing Procedures:

(a). plain x-rays including AP view and lateral of the entire humeral shaft.

(b). vascular studies if the radial pulse is absent.

(c). compartment pressure measurements if the surrounding muscles are swollen, tense and painful and particularly if the fracture resulted from a crush injury.

iv. Non-operative Treatment Procedures:

(a). Most isolated humeral shaft fractures can be managed non-operatively.

(b). Medication, such as analgesics and nonsteroidal anti-inflammatories, would be indicated. Narcotics may be indicated acutely for fracture and should be prescribed as indicated in Section F.6, Medications.

(c). A coaptation splint may be used.

(d). At two to three weeks after injury, a humeral fracture orthosis may be used to allow for full elbow motion.

(e). Return to work with appropriate restrictions should be considered early in the course of treatment. Refer to Return to Work.

(f). Other therapies outlined in Therapeutic Procedures, Non-operative, may be employed in individual cases.

(g). Refer to comments related to osteoporosis in Clavicular Fracture.

(h). Smoking may affect fracture healing. Patients should be strongly encouraged to stop smoking and provided with appropriate counseling.

v. Surgical Indications: Indications for operative care would include:

(a). open fracture;

(b). associated forearm or elbow fracture (i.e., the floating elbow injury);

(c). burned upper extremity;

(d). associated paraplegia;

(e). multiple injuries (polytrauma);

(f). A radial nerve palsy which presented after closed reduction;

(g). pathologic fracture related to an occupational injury; and/or

(h). inability to perform basic activities of daily living while following conservative care.

(i). because smokers have a higher risk of non-union and post-operative costs, it is recommended that carriers cover a smoking cessation program peri-operatively.

vi. Operative Procedures

(a). Accepted methods of internal fixation of the fracture include:

(i). A broad plate and screws; and/or

(ii). Intramedullary rodding with or without cross-locking screws may be used but is associated with increased shoulder pain;

(b). Human Bone Morphogenetic Protein (RhBMP). Use of this material for surgical repair of shoulder fractures requires prior authorization. Refer to Operative Procedures, for further details.

vii. Post-Operative Treatment: An individualized rehabilitation program based upon communication between the surgeon and the therapist using the treatments found in Therapeutic Procedures, Non-operative. Treatment may include the following:

(a). Following rigid internal fixation, therapy may be started to obtain passive and later active shoulder motion using appropriate therapeutic approaches as indicated in Section F, Non-operative Treatment Procedures. Active elbow and wrist motion may be started immediately. Early therapeutic rehabilitation interventions are recommended to maintain range-of-motion (ROM) and progressive strengthening.

(i). Frequency: Three to five times per week for the first two weeks, three times per week for the following two weeks, then to two times per week.

(ii). Optimum Duration: Six to eight weeks with progression to home exercise and/or pool therapy.

(iii). Maximum Duration: 12 weeks. Additional follow-up visits may be justified to reinforce exercise patterns or to reach final functional goals if the therapy to date has demonstrated objective functional gains or if a nerve injury accompanies the fracture.

(b). Return to work and restrictions after surgery may be made by an experienced primary occupational medicine physician in consultation with the surgeon or by the surgeon.

(c). Bone Growth Stimulation. (Refer to Clavicular Fractures.)

d. Scapular Fractures:

i. Occupational Relationship. These are the least common of the fractures about the shoulder and include acromial, glenoid, glenoid neck and scapular body fractures. With the exception of anterior glenoid lip fractures caused by an anterior shoulder dislocation, all other scapular fractures are due to a high-energy injury.

ii. Specific Physical Findings may include:

(a). pain about the shoulder and thorax;

(b). bruising and abrasions;

(c). possibility of associated humeral or rib fractures; and/or

(d). vascular problems (pulse evaluation and Doppler examination).

iii. Diagnostic Testing Procedures:

(a). Trauma x-ray series - AP view, axillary view, and a lateral view in the plane of the scapula.

(b). Arteriography if a vascular injury is suspected.

(c). Electromyographic exam if nerve injuries are noted.

iv. Non-operative Treatment:

(a). Non-displaced acromial, coracoid, glenoid, glenoid neck and scapular body fractures may all be treated with the use of a shoulder immobilizer.

(b). Medication, such as analgesics and nonsteroidal anti-inflammatories, would be indicated. Narcotics may be indicated acutely for fracture and should be prescribed as indicated in Medications.

(c). Pendulum exercises may be started within the first week.

(d). Progress to assisted range-of-motion exercises at three to four weeks using appropriate therapeutic procedures as indicated in Section F, Non-operative Treatment Procedures.

(e). Return to work with appropriate restrictions should be considered early in the course of treatment. Refer to Return to Work.

(f). Refer to comments related to osteoporosis in Clavicular Fracture.

(g). Smoking may affect fracture healing. Patients should be strongly encouraged to stop smoking and provided with appropriate counseling.

v. Surgical Indications

(a). displaced acromial fractures.

(b). displaced glenoid fractures.

(c). displaced scapular body fractures in some circumstances.

(d). displaced fractures of the scapular neck and the ipsilateral clavicle.

(e). because smokers have a higher risk of non-union and post-operative costs, it is recommended that carriers cover a smoking cessation program peri-operatively.

vi. Operative Treatment

(a). displaced acromial fractures are treated with internal fixation.

(b). displaced glenoid fractures greater than 5 mm should be fixed internally. Fractures with less displacement may be treated surgically according to the surgeon's discretion. Two and three dimensional CT scans may be useful in planning the surgical approach.

(c). displaced scapular body fractures require internal fixation if the lateral or medial borders are displaced to such a degree as to interfere with scapulothoracic motion.

(d). displaced fractures of the scapular neck and the ipsilateral clavicle require internal fixation of the clavicle to reduce the scapular neck fracture.

vii. Post-Operative Treatment: An individualized rehabilitation program based upon communication between the surgeon and the therapist using the appropriate therapeutic procedures as indicated in Section F, Non-operative Treatment Procedures. Treatment may include the following:

(a). A shoulder immobilizer is utilized. Pendulum exercises initially begin at one week, and deltoid isometric exercises are started early at four to six weeks, active ROM is usually commenced.

(b). Early therapeutic rehabilitation interventions are recommended to maintain ROM with progressive strengthening.

(i). Frequency: Three to five times per week for the first two weeks, three times per week for the following two weeks, then one to two times per week.

(ii). Optimum Duration: 8 to 10 weeks with progression to home exercise and/or pool therapy.

(iii). Maximum Duration: 12 to 14 weeks. Occasional follow-up visits may be justified to reinforce exercise patterns or to reach final functional goals if the therapy to date has demonstrated objective functional gains.

(c). Return to work and restrictions after surgery may be made by an experienced primary occupational medicine physician in consultation with the surgeon or by the surgeon.

e. Sternoclavicular Dislocation/Fracture

i. Occupational Relationship: Sudden trauma to the shoulder/anterior chest wall. Anterior dislocations of the sternoclavicular joint usually do not require active treatment; however, symptomatic posterior dislocations will require reduction.

ii. Specific Physical Findings may include:

(a). Dysphagia and shortness of breath which requires emergency reduction.

(b). Pain at the sternoclavicular area;

(c). Abrasions on the chest wall, clavicle and shoulder;

(d). Deformities in the above regions; and/or

(e). Pain with palpation and motion at the sternoclavicular joint area.

iii. Diagnostic Testing Procedures:

(a). Plain x-rays of the sternoclavicular joint are routinely done. When indicated, comparative views of the contralateral limb may be necessary.

(b). X-rays of other shoulder areas and chest may be done if clinically indicated.

(c). CT scan for classification of pathology.

(d). Vascular studies should be considered if the history and clinical examination indicate extensive injury.

iv. Non-operative Treatment Procedures:

(a). Symptomatic posterior dislocations should be reduced in the operating room under general anesthesia.

(b). Immobilize with a sling for three to four weeks. Subsequently, further rehabilitation may be utilized using procedures set forth in Non-operative Treatment Procedures.

(c). Medications, such as analgesics and nonsteroidal anti-inflammatories, would be indicated. Narcotics may be indicated acutely for fracture and should be prescribed as indicated in Medications.

(d). Return to work with appropriate restrictions should be considered early in the course of treatment. Refer to Return to Work.

(e). Refer to comments related to osteoporosis in Clavicular fracture.

(f). Smoking may affect fracture healing. Patients should be strongly encouraged to stop smoking and provided with appropriate counseling.

v. Surgical Indications:

(a). failure of closed reduction.

(b). because smokers have a higher risk of non-union and post-operative costs, it is recommended that carriers cover a smoking cessation program peri-operatively.

vi. Operative Procedures

(a). reduction with soft tissue reconstruction is preferred;

(b). internal fixation - significant complications can occur with use of pins due to migration into other tissues.

vii. Post-Operative Treatment: An individualized rehabilitation program based upon communication between the surgeon and the therapist. This program would begin with four to six weeks of rest with a shoulder immobilizer, followed by therapeutic rehabilitation interventions.

(a). Early therapeutic rehabilitation interventions are recommended to maintain ROM with progressive strengthening.

(i). Frequency: Three to five times per week for the first two weeks, three times per week for the following two weeks, then one to two times per week.

(ii). Optimum Duration: Six to eight weeks with progression to home exercise and/or pool therapy.

(iii). Maximum Duration: 12 weeks. Occasional follow-up visits may be justified to reinforce exercise patterns or to reach final functional goals if the therapy to date has demonstrated objective functional gains.

(b). Return to work and restrictions after surgery may be made by an experienced primary occupational medicine physician in consultation with the surgeon or by the surgeon.

### 13. Impingement Syndrome

a. Description/Definition: A collection of symptoms, not a pathologic diagnosis. The symptoms result from the encroachment of the acromion, coracoacromial ligament, coracoid process, and/or the AC joint of the rotator cuff mechanism that passes beneath them as the shoulder is moved. The cuff mechanism is intimately related to the coracoacromial arch. Separated only by the thin lubricating surfaces of the bursa, compression and friction can be minimized by several factors, such as:

- i. shape of the coracoacromial arch that allows passage of the subjacent rotator cuff;
- ii. normal undersurface of the AC joint;
- iii. normal bursa;
- iv. normal capsular laxity; and
- v. coordinated scapulothoracic function.

b. The impingement syndrome may be associated with AC joint arthritis and both partial and full thickness rotator cuff tears, as well as, adhesive capsulitis/frozen shoulder. Normal function of the rotator cuff mechanism and biceps tendon assist to diminish impingement syndrome.

i. History may include

(a). delayed presentation (since the syndrome is usually not an acute problem). Patients will access care if their symptoms have not resolved with rest, time and "trying to work it out";

(b). complaints of functional losses due to pain, stiffness, weakness and catching when the arm is flexed and internally rotated; and

(c). sleep complaints are common and pain is often felt down the lateral aspect of the upper arm near the deltoid insertion or over the anterior proximal humerus.

(d). occupational Relationship: Repetitive overuse of the upper extremity, often seen with constant overhead motion.

c. specific Physical Exam Findings may include: As with most shoulder diagnoses, the examiner should not rely upon one set of physical exam findings alone due to the lack of specificity and sensitivity of most tests and common overlap of diagnoses. Physical examination findings may include the following:

i. Range-of-motion is limited particularly in internal rotation and in cross-body adduction, which may reflect posterior capsular tightness. Forward flexion and elevation may also be limited.

ii. Passive motion through the 60 to 90 degrees arc of flexion may be accompanied by pain and crepitus. This is accentuated as the shoulder is moved in-and-out of internal rotation.

iii. Active elevation of the shoulder is usually more uncomfortable than passive elevation.

iv. Pain on maximum active forward flexion is frequently seen with impingement syndrome, but is not specific for diagnosis.

v. Strength testing may reveal weakness of flexion and external rotation in the scapular plane. This weakness may be the result of disuse, tendon damage, or poor scapulothoracic mechanics.

vi. Pain on resisted abduction or external rotation may also indicate that the integrity of the rotator cuff tendons may be compromised, causing alteration of shoulder mechanics.

vii. Weakness of the posterior scapular stabilizers causing alteration of shoulder mechanics can also contribute to impingement syndrome.

viii. If inspection of the shoulder reveals deltoid and rotator cuff atrophy other diagnoses should be suspected such as cervical radiculopathy, axillary nerve pathology, or massive rotator cuff tears.

(a). Impingement syndromes commonly co-exist with other shoulder abnormalities such as rotator cuff tears, AC joint arthritis, biceps tendon ruptures, calcifying tendonitis, bursitis, labral tears, and in older patients, glenohumeral instability. This combination of pathology further complicates diagnostic decisions based mainly on clinical findings. Physicians use a combination of test results with history and other findings to create a differential diagnosis.

(b). Commonly used clinical tests include the following:

- (i). Hawkins;
- (ii). Neer;

- (iii). Horizontal adduction;
- (iv). Drop arm test;
- (v). Yergason's;
- (vi). Speed test.

(c). Diagnostic Testing Procedures

- (i). Plain x-rays include:

[a]. AP view is useful to evaluate for arthritis and elevation of the humeral head which are not typically present in impingement syndrome.

[b]. Lateral view in the plane of the scapula or an axillary view can help to determine aspects of instability which can give symptoms similar to impingement syndrome.

[c]. Axillary view is also useful to demonstrate glenohumeral arthritis and spurs on the anterior inferior acromion.

[d]. Outlet view determines if there is a downward curved acromion. A downward curved acromion does not necessarily establish the diagnosis of impingement syndrome and is not a sole indication for operative treatment.

(ii). Adjunctive testing, sonography or MRI, may be considered when shoulder pain is refractory to four to six weeks of non-operative conservative treatment and the diagnosis is not readily identified by a good history and clinical examination. (Refer to Follow-up Diagnostic Procedures.)

(iii). The subacromial injection has generally been considered the gold standard for differentiating ROM loss from impingement versus rotator cuff tears. Alleviation from pain may help to confirm the diagnosis. Patients with impingement should recover normal strength after the injection, while those with rotator cuff tears usually do not recover normal strength. However, manually tested elevation strength perceived as normal does not always rule out rotator cuff tear and this may contribute to incorrect diagnoses with this technique. There is good evidence that blinded subacromial blocks are not accurate. Up to a third of blinded injections may involve the cuff, and are likely to cause pain. This may lead to an incorrect diagnosis. One study demonstrated that at least half of the positive responders did so up to 40 minutes after the injection. Therefore, a negative response should not be diagnosed until 40 minutes post injection. The inaccuracy of the injection and patient response in some cases may contribute to its inability to completely predict the amount of recovery from subacromial decompression.

(iv). If there is a concern regarding needle placement, sonography or fluoroscopy may be used.

(v). Steroid injections should be used cautiously in diabetic patients. Diabetic patients should be reminded to check their blood glucose level at least daily for two weeks after injections.

(d). Non-operative Treatment Procedures

(i). An aggressive attempt should be made to define the contributing factors which are driving the syndrome, such as shoulder stiffness, humeral head depressor weakness (rotator cuff fiber failure), posterior capsular tightness and subacromial crowding, AC joint arthritis, muscle imbalance, and postural dysfunction.

(ii). Benefits may be achieved through therapeutic interventions. They should include ROM, active therapies, and a home exercise program. Passive as well as active therapies may be used for control of pain and swelling. Therapy should progress to strengthening and an independent home exercise program targeted to further improve ROM and strength of the shoulder girdle musculature. Refer to Therapeutic Procedures, Non-operative.

(iii). There is some evidence that manual therapy at a frequency of three times per week for four weeks, increases function and decreases pain.

(iv). Patients may return to work without overhead activities and lifting with involved arm. An evaluation of the jobsite may be necessary to institute ergonomic changes or accommodations. Return to work with appropriate restrictions should be considered early in the course of treatment. Refer to Return to Work.

(v). Medications, such as nonsteroidal anti-inflammatories and analgesics, should be prescribed. Refer to Medications.

(vi). Subacromial space injection may be therapeutic. Injections under significant pressure should be avoided as the needle may be penetrating the tendon and injection into the tendon can cause tendon degeneration, tendon breakdown, or rupture. Injections should be minimized for patients under 30 years of age.

[a]. Time to Produce Effect: One Injection.

[b]. Maximum: Three injections at the same site per year when functional benefits are demonstrated with each injection. Steroid injections should be used cautiously in diabetic patients. Diabetic patients should be reminded to check their blood glucose level at least daily for two weeks post injections.

(vii). Other therapies in Therapeutic Procedures, Non-operative may be employed in individual cases.

(e). Surgical Indications

(i). When functional deficits interfere with activities of daily living and/or job duties after three to six months of active patient participation in non-operative therapy, surgery may restore functional anatomy and reduce the potential for repeated impingement. Prior to surgical intervention, the patient and treating physician should identify functional operative goals and the likelihood of achieving improved ability to perform activities of daily living or work activities and the patient should agree to comply with the pre- and post-operative treatment plan including home exercise. The provider should be especially

careful to make sure the patient understands the amount of post-operative therapy required and the length of partial and full disability expected post-operatively.

(f). Operative Procedures

(i). Procedures might include partial coracoacromial ligament release, and an acromioplasty, as well as, repair of associated pathology. An acromioplasty is not always necessary as an adjunct to rotator cuff repair. There is some evidence that patients with a full-thickness rotator cuff tear and Type II acromions do not show appreciable benefit from subacromial decompression.

(ii). Coplaning of the clavicle involves the removal of spurs from its inferior surface with the purpose of increasing the space available for movement of the supraspinatus tendon. It is an acceptable procedure. Studies are conflicting regarding possible pain sequelae at the acromioclavicular joint as a consequence of the procedure. In cases with extensive rotator cuff repair, preservation of the coraco-acromial ligament is recommended to maintain joint stability.

(g). Post-Operative Treatment

(i). An individualized rehabilitation program based upon communication between the surgeon and the therapist using the treatments found in Therapeutic Procedures, Non-operative. Treatment may include the following:

(ii). sling, pillow sling, or abduction splint;

(iii).gentle pendulum exercise, passive glenohumeral range-of-motion, and posterior scapular stabilizing training can be instituted;

(iv).patients can judiciously return to activities as tolerated per physician recommendations. If there is a significant tendon repair, progression will be delayed;

(v). Progressive resistive exercise from six to eight weeks with gradual returning to full activity at four to six months.

(vi).Return to work and restrictions after surgery may be made by an experienced primary occupational medicine physician in consultation with the surgeon or by the surgeon. Depending upon the patient's functional response and their job requirements, return to work with job modifications may be considered as early as one week post-operatively, depending on job requirements. The employer must be able to fully accommodate restrictions of overhead activities or heavy lifting. Work restrictions should be evaluated every four to six weeks during post-operative recovery and rehabilitation with appropriate written communications to both the patient and the employer. Should progress plateau, the provider should re-evaluate the patient's condition and make appropriate adjustments to the treatment plan.

14. Rotator Cuff Tear

a. Description/Definition: Partial or full-thickness tears of the rotator cuff tendons, most often the

supraspinatus, can be caused by vascular, traumatic or degenerative factors or a combination. Further tear classification includes: a small tear is less than 1cm; medium tear is 1 to 3cm; large tear is 3 to 5cm; and massive tear is greater than 5cm, usually with retraction. Partial thickness cuff tears usually occur in age groups older than 30. Full-thickness tears can occur in younger age groups. Patient usually complains of pain along anterior, lateral shoulder or posterior glenohumeral joint.

b. Occupational Relationship: May be caused by sudden trauma to the shoulder such as breaking a fall using an overhead railing or an out-stretched arm; or chronic overuse with repetitive overhead motion or heavy lifting; or moderate lifting in de-conditioned workers.

c. Specific Physical Exam Findings may include

i. partial Thickness Tear

(a). There may be pain at the end of range-of-motion (ROM) when full passive ROM for abduction, elevation, external rotation and internal rotation are obtainable;

(b). Occasionally, there is a restriction of passive motion in one or more planes;

(c). Active ROM will be limited and painful for abduction and external rotation, as well as internal rotation and forward flexion;

(d). A painful arc may be present with active elevation;

(e). Pain will be positive for resisted tests (abduction, flexion, external rotation, internal rotation, abduction/internal rotation at 90 degrees, and abduction/external rotation at 45 degrees); and/or

(f). There may be positive impingement signs, refer to Impingement Syndrome.

ii. Full-Thickness Tear

(a). Passive and resisted findings are similar to those for partial thickness tears with greater weakness of abduction and external rotation;

(b). Active elevation may be severely limited with substitution of scapular rotation;

(c). Occasionally strength remains well preserved.

(d). Rotator cuff tears commonly co-exist with other shoulder abnormalities such as impingement, AC joint arthritis, bicep tendon ruptures, calcifying tendonitis, and older patients with glenohumeral instability, bursitis, and labral tears. This combination of pathology further complicates diagnostic decisions based mainly on the clinical findings. Full-thickness tears are usually readily apparent from the drop arm test or weakness with elevation. For other diagnoses, physicians should use a combination of test results with history and other findings to create a differential diagnosis. The following tests may be used:

- (i). hawkins;
- (ii). drop arm;
- (iii). lift off;
- (iv). subscapularis strength test;
- (v). empty can test;
- (vi). external rotation lag test.

(e). Neurological lesions can occur with rotator cuff tears or may be missed as isolated lesions. When muscle atrophy and weakness are present, the physician should consider neurologic lesions in the differential diagnoses.

#### d. Diagnostic Testing Procedures

i. AP view is useful to evaluate for arthritis and elevation of the humeral head. Superior migration of the humeral head is indicative of an extensive, and possibly irreparable, rotator cuff tear.

ii. Lateral view in the plane of the scapula or an axillary view can help to determine aspects of instability which can give symptoms similar to impingement syndrome.

iii. The axillary view is also useful to demonstrate glenohumeral arthritis and spurs on the anterior inferior acromion.

iv. Outlet view determines if there is a downward curved acromion. A downward curved acromion does not necessarily establish the diagnosis of impingement syndrome and is not a sole indication for operative treatment.

(a). Cases with the presence of significant weakness on elevation or rotation, a palpated defect at the greater tuberosity or a traumatic history should have early MRI. Adjunctive testing such as sonography or MRI should be considered for other shoulder cases refractory to four to six weeks of non-operative conservative treatment. Sonography may be better at detecting partial thickness tears but is operator dependent. The sonogram is very specific for rotator cuff tears but is not sensitive.

(b). Rotator cuff tears, both full-thickness and partial, appear to occur commonly in asymptomatic individuals. Sonographic diagnostic criteria for rotator cuff tear may be met in approximately 39 percent of asymptomatic persons, and MRI criteria for rotator cuff tear may occur in approximately 26 percent of asymptomatic persons. There also appears to be a linear trend with age, such that more than half of asymptomatic individuals over the age of 60 may demonstrate imaging changes consistent with rotator cuff tear, while a small minority of patients younger than 40 demonstrate these changes. Correlation of radiological and clinical findings is an important part of patient management.

#### e. Non-operative Treatment Procedures

i. Medications, such as nonsteroidal anti-inflammatory and analgesics, would be indicated. Acute

rotator cuff tear may indicate the need for limited narcotics use.

ii. Relative rest initially and procedures outlined in Non-Operative Treatment Procedures. Therapeutic rehabilitation interventions may include ROM and use a home exercise program and passive modalities for pain control. Therapy should progress to strengthening and independent home exercise programs targeted to ongoing ROM and strengthening of shoulder girdle musculature.

iii. Return to work with appropriate restrictions should be considered early in the course of treatment. Refer to Return to Work.

iv. Other therapies outlined in Therapeutic Procedures, Non-operative, may be employed in individual cases.

#### f. Surgical Indications

i. Goals of surgical intervention are to restore functional anatomy by re-establishing continuity of the rotator cuff, addressing associated pathology and reducing the potential for repeated impingement.

ii. Surgery may be indicated when functional deficits interfere with activities of daily living and/or job duties after 6 to 12 weeks of active patient participation in non-operative therapy.

iii. If no increase in function for a partial tear is observed after 6 to 12 weeks, a surgical consultation is indicated. For full-thickness tears it is thought that early surgical intervention produces better surgical outcome due to healthier tissues and often less limitation of movement prior to and after surgery. Patients may need pre-operative therapy to increase ROM.

iv. Full-thickness tears in individuals less than 60 should generally be repaired. Surgery for partial thickness tears has variable results and debridement should be performed early in younger active patients. Many patients with partial tears and good ROM and strength recover well without surgery. In patients over 65 the decision to repair a full rotator cuff tear depends on the length of time since the injury, the amount of muscle or tendon that has retracted, the level of fatty infiltration and the quality of the tendon. Procedures for these patients may include biceps tendon repair and shaving of the humeral tuberosity. For patients with lack of active elevation above 90 degrees, arthroscopic biceps tenotomy and tenodesis may be effective in returning some elevation. Recurrence rate may be up to 50 percent in older patients with multiple tendon full-thickness tears. Pseudo paralysis or severe rotator cuff arthropathy are contraindications to the procedure.

v. Literature suggests that the presence of three of the following factors may decrease the likelihood of a successful repair: decreased passive ROM, superior migration of the humeral head, presence of atrophy, and/or external rotation/abduction weakness strength. Presence of these conditions is not necessarily contraindications to



surgery, however, the patient should be made aware that the outcome may be less predictable.

vi. Prior to surgical intervention, the patient and treating physician should identify functional operative goals and the likelihood of achieving improved ability to perform activities of daily living or work activities and the patient should agree to comply with the pre- and post-operative treatment plan and home exercise requirements. The patient should understand the length of partial and full disability expected post-operatively.

vii. Smoking may affect soft tissue healing through tissue hypoxia. Patients should be strongly encouraged to stop smoking and provided with appropriate counseling.

g. Operative Procedures:

i. Options would include arthroscopic or open debridement and/or repair. In some cases, partial coracoacromial ligament release, and/or anterior acromioplasty.

ii. An acromioplasty is not always necessary as an adjunct to rotator cuff repair. There is some evidence that patients with a full-thickness rotator cuff tear and Type II acromions do not show appreciable benefit from subacromial decompression.

iii. Coplaning of the clavicle involves the removal of spurs from its inferior surface with the purpose of increasing the space available for movement of the supraspinatus tendon. It is an acceptable procedure. Studies are conflicting concerning the consequences of the procedure for the stability of the acromioclavicular joint.

iv. Distal clavicular resection is not recommended for patients without AC joint pain.

v. In cases with extensive rotator cuff tear, preservation of the coracoacromial ligament is recommended to prevent instability.

vi. Arthroscopic laser treatment is not recommended due to lack of evidence regarding outcomes.

h. Post-Operative Treatment: Individualized rehabilitation program based upon communication between the surgeon and the therapist. Treatment may include the following:

i. Sling, pillow sling, or abduction splint. Sling protection for a period of two to eight weeks is usually recommended after rotator cuff repair;

ii. Gentle pendulum exercise, passive glenohumeral range-of-motion in flexion and external rotation to prevent adhesions and maintain mobilization;

iii. Isometrics and activity of daily living skills usually being six weeks post-operatively.

iv. Active assisted range-of-motion exercises in supine with progression to sitting;

v. Light resistive exercise may begin at 6 to 12 weeks, depending on quality of tissue and surgeon's discretion;

vi. Pool exercise initially under therapists or surgeon's direction then progressed to independent pool program;

vii. Progression to a home exercise program is essential;

viii. Gradual resistive exercise from 3 to 12 months, with gradual return to full activity at 6 to 12 months;

ix. Time frames for therapy (excluding pool therapy).

(a). Optimum: 24 to 36 sessions.

(b). Maximum: 48 sessions. If functional gains are being achieved additional visits may be authorized for the patient to achieve their functional goal.

x. Continuous passive motion is not generally recommended. It may be used if the patient has no home assistance to regularly perform the passive movements required in the first six weeks and/or access to therapy is limited.

xi. Should progress plateau, the provider should re-evaluate the patient's condition and make appropriate adjustments to the treatment plan. Refer to Therapeutic Procedures-Non-Operative for other therapies that may be employed in individual cases.

xii. Return to work and restrictions after surgery may be made by an experienced primary occupational medicine physician in consultation with the surgeon or by the surgeon. Work restrictions should be evaluated every four to six weeks during post-operative recovery and rehabilitation with appropriate written communications to both the patient and employer. Return to full-duty too early in the course of tendon recovery increases the likelihood of recurrent, symptomatic tears. Animal models estimate that the infraspinatus tendon regains only 30 percent of strength at six weeks, 50 percent at three months, and 80 percent at six months. Therefore, return to any significant lifting early in the course of recovery may result in failure of the surgery and/or recurrent tears.

#### 15. Shoulder Instability/Glenohumeral Instability

a. Description/Definition: Subluxation (partial dislocation), or dislocation of the glenohumeral joint in either an anterior, interior, posterior or a combination of positions.

i. History may include:

(a). a slipping sensation in the arm;

(b). severe pain with inability to move the arm;

(c). abduction and external rotation producing a feeling that the shoulder might "come out"; or

(d). feeling of shoulder weakness.

b. Occupational Relationship: Instability may be caused by any of the following:

- i. a direct traumatic blow to the shoulder;
  - ii. a fall on an outstretched arm;
  - iii. performing repetitive forceful overhead activities similar to pitching baseball;
  - iv. a significant traction injury to the arm.
- v. In cases of subluxation symptoms may be exacerbated or provoked by work and initially alleviated with a period of rest. Symptoms may also be exacerbated by other activities that are not necessarily work related (e.g., driving a car or sports).

c. Specific Physical Exam Findings may include

i. Anterior dislocations may exhibit loss of normal shoulder contour; fullness in the axilla and pain over the shoulder with any motion. The patient may hold the extremity in a static position;

ii. Posterior dislocations usually occur with a direct fall on the shoulder or outstretched arm resulting in posteriorly directed forces to the humeral head. Seizures or electrocution may also cause posterior dislocations. Patients present with inability to externally rotate the shoulder;

iii. Neurologic examination may reveal findings consistent with axillary nerve injuries, musculocutaneous nerve injuries, generalized brachioplexopathies or other entrapment neuropathies;

iv. Abduction and external rotation positioning classically produces apprehension in those who have anterior instability. This finding may be present with other diagnoses. If apprehension is reproduced and then relieved with positive posterior pressure after a positive first maneuver, this is considered a positive relocation test. As with all shoulder diagnoses, a combination of physical findings and history should guide the provider in determining the final diagnoses. Direct posterior stress may produce pain and apprehension in those with posterior instability;

v. The contralateral joint should always be examined. Patients who have laxity in multiple positions, who have contralateral joint laxity or who have increased external rotation (90 degrees or more) with the arm at the side are not likely to be surgical candidates and can be treated conservatively.

vi. Other clinical findings (described in the Initial Diagnostic Procedures Section C):

- (a). sulcus sign;
- (b). inferior instability;
- (c). posterior instability;
- (d). apprehension, also known as crank, fulcrum or feagin;
- (e). relocation;

(f). load and shift or anterior and posterior drawer.

d. Diagnostic Testing Procedures

i. Plain x-rays to rule out bony deficit on the glenoid, including AP, axillary view, lateral in the plane of the scapula and possibly the West Point view. Axillary view to identify larger Hill-Sachs lesion of humeral head.

ii. More difficult diagnostic cases with subtle history and physical findings suggesting instability, rotator cuff or labral tear, may require a MRI or a CT arthrogram. This imaging may be useful to evaluate for labral detachment and capsular stress injury or laxity after four to eight weeks of active patient involvement in therapy.

iii. Suspected rotator cuff tear cases may require diagnostic arthroscopy.

e. Non-Operative Treatment Procedures: In subacute and/or chronic instabilities, age of onset of instability is an important part of the history. Older patients are less likely to have recurrent dislocations unless they have associated large rotator cuff tears. Therefore, the rotator cuff tear protocol should be followed if there is a suspicion of this pathology. Associated axillary nerve injuries are more common in older patients. Patients less than 30 years of age, especially males actively participating in sports, tend to have a higher recurrence rate, up to 75 percent in some series. Surgery should be considered for these patients after the first dislocation. Avoid any aggressive treatment in patients with history of voluntary subluxation or dislocation. These patients may need a psychiatric evaluation. Patient may not return to work with overhead activity or lifting with involved arm until cleared by physician for heavier activities.

i. First-time dislocation

(a). Immobilization. There is no evidence that immobilization beyond splinting for comfort initially affords any additional treatment advantage thus, it is not routinely required. Literature using MRI has shown that the Bankart lesion is separated from the bone in internal rotation and apposed to the bone in external rotation. There is some evidence that immobilization for three weeks with the shoulder in adduction and approximately 10 degrees of external rotation reduces the risk of recurrent dislocation. Decisions concerning external rotation splinting versus other options will depend on surgeon and patient preferences.

(b). Consider surgical intervention for young patients active in sports, or older patients with significant rotator cuff tears. If additional pathology is present consult appropriate diagnostic categories.

(c). Medications such as analgesics and anti-inflammatory may be helpful. (Refer to medication discussions in Medications.

(d). Other therapeutic procedures may include instruction in therapeutic exercise and proper work techniques, evaluation of occupational work station and passive modalities for pain control. (Refer to Therapeutic Procedures-Non operative, for specific time parameters.)

(e). Additional treatment may include, depending on level of improvement, manual therapy techniques, work conditioning and other treatment found in section F.

(f). Patient may not return to work with overhead activity or lifting with involved arm until cleared by physician for heavier activities. Return to work with appropriate restrictions should be considered early in the course of treatment. Refer to Return to Work.

ii. Acute or chronic dislocations: with a fracture contributing to instability;

(a). Practitioner should immobilize dislocations if in an acceptable position. Consultation should be obtained as surgical repair may be necessary.

(b). Return-to-work will be directly related to the time it takes the fracture to heal.

iii. Subacute and/or chronic instability:

(a). Chronic dislocations should first be treated similarly to acute dislocation. If continuing treatment is unsuccessful, with findings of instability, operative repair should be considered.

f. Surgical Indications

i. Identify causative agent for the instability (i.e., labral detachment, bony lesion, large rotator cuff tear, subscapularis tendon rupture, or multi-directional instability). There is strong evidence that initial operative repair in young active patients results in fewer recurrent dislocations, thus, operative repair should be considered for these patients. Those with Hill Sachs lesions, bony Bankart injuries, or significant glenoid bone loss have a worse prognosis for recurrences.

ii. Fractures not amenable to immobilization may also need operative management after the first dislocation. Even with open repairs some decrease in function should be expected. Loss of external rotation is common. In some cases the loss of motion may have an adverse effect on post-operative function. The desire for surgery should carefully balance the desire to prevent recurrent dislocations and the need for ROM.

iii. Older patients with documented large rotator cuff tears should also be considered for operative repair after first time dislocations. Repair of the rotator cuff tear alone or in combination with stabilization should be considered. Refer to the rotator cuff tear section.

iv. In general, older patients without the above lesions will suffer few recurrences, and therefore, are treated conservatively. Operative repair may be considered only after recurrent dislocations when functional deficits interfere with activities of daily living and/or job duties and active patient participation in non-operative therapy has occurred. Patients with multi-directional laxity and/or laxity in the contralateral shoulder are usually not good candidates for operative repair.

g. Operative Procedures:

i. Bankart lesion repair; or  
 ii. Capsular tightening. There is no evidence of benefit from thermal capsulorrhaphy and it is not recommended;

iii. Bony block transfer;

h. Post-Operative Treatment:

i. An individualized rehabilitation program based upon communication between the surgeon and the therapist. Depending upon the type of surgery, the patient will be immobilized for three to six weeks.

ii. As soon as it is safe to proceed without damaging the repair, begin therapeutic exercise. Pool therapy may be beneficial. Refer to Therapeutic Procedures, Non-operative for other therapies.)

iii. During this period of time, the patient could resume working when the surgeon has cleared the patient for specific activities and appropriate modifications can be made in the workplace. Return to work and restrictions after surgery may be made by an experienced primary occupational medicine physician in consultation with the surgeon or by the surgeon. Full ROM, lifting and pushing are prohibited usually for at least three months. Overhead work may be restricted up to six months.

iv. MMI can be expected three months after non-operative treatment and 6 to 12 months after operative treatment. Further job assessment and adjusted work restrictions may be needed prior to the patients return to full-duty.

16. Superior Labrum Anterior and Posterior (Slap) Lesions

a. Description/Definition: Lesions of the superior aspect of the glenoid labrum that extend anteriorly and posteriorly in relation to the biceps tendon insertion. There are several different types of SLAP lesions described.

i. Type I is a fraying of the superior labral edge without detachment of the labrum from the glenoid rim.

ii. Type II is a detachment of the biceps anchor from the glenoid. Three distinct Type II lesions have been described as anterior only, posterior only, or combined anterior and posterior.

iii. Type III is a bucket handle tear in the superior labrum only with biceps tendon and remainder of the superior labrum having stable attachment.

iv. Type IV is a bucket handle tear as in Type III, but with extension of the tear in to the biceps tendon. Additional types of lesions have been described that include extensions of the above-described lesions or extensions of Bankart lesions.

v. History may include:

(a). Symptoms with overhead throwing motions;

(b). Dislocation, subluxation, or subjective sense of instability;

(c). Poorly localized shoulder pain that is exacerbated by overhead activities;

(d). Catching, locking, popping or snapping;

(e). Subtle instability.

b. Occupational Relationship: Common mechanisms of injury that are thought to contribute to SLAP lesions include: compression injury such as fall on an outstretched arm with the shoulder in forward flexion and abduction or direct blow to the glenohumeral joint; traction injury such as repetitive overhead throwing, attempting to break a fall from a height, and sudden pull when losing hold of a heavy object; driver of an automobile who is rear ended; repetitive overhead motions with force such as pitching; or a fall on adducted arm with upward force directed on elbow. In some cases no mechanism of injury can be identified.

c. Specific Physical Exam Findings: The physical examination is often nonspecific secondary to other associated intra-articular abnormalities. No one test or combination of tests has been shown to have an acceptable sensitivity and specificity or positive predictive values for diagnosing SLAP lesion. Sensitivity and specificity are relatively low for individual tests and combinations. Overall physical examination tests for SLAP lesions may be used to strengthen a diagnosis of SLAP lesion, but the decision to proceed to operative management should not be based on physical examination alone. Refer to Initial Diagnostic Procedures for specific descriptions of these signs and tests.

i. Speed Test.

ii. Yergason's Test.

iii. Active Compression (O'Brien) Test.

iv. Jobe Relocation Test.

v. Crank Test.

vi. Anterior Apprehension Maneuver.

vii. Tenderness at the bicipital groove.

viii. Anterior Slide (Kibler) Test.

ix. Compression Rotation Test.

x. Pain Provocation Test.

xi. Biceps Load Test II.

d. Diagnostic Testing Procedures:

i. Radiographs are usually normal in isolated SLAP lesions. However, they can be useful in identifying other sources of abnormalities.

ii. Magnetic resonance imaging with arthrogram has the highest reported accuracy for both diagnosis and classification of SLAP lesions; however, it may be difficult to differentiate SLAP lesions, especially Type II lesions, from normal anatomic variants and from asymptomatic age related changes.

iii. Arthroscopic evaluation is the most definitive diagnostic test.

e. Non-operative Treatment Procedures: Most SLAP lesions are associated with other pathology such as rotator cuff tears, Bankart lesions, joint instability, biceps tendon tears, and supraspinatus tears. The provider should refer to the treatment protocols for these conditions and follow both the surgical and non surgical recommendations. For suspected isolated SLAP lesions, non invasive care, consider the following.

i. Medications such as analgesics and anti-inflammatories may be helpful. (Refer to medication discussions are in Medications.)

ii. Therapeutic procedures may include instruction in therapeutic exercise and proper work techniques, evaluation of occupational work station.

iii. Benefits may be achieved through therapeutic rehabilitation and rehabilitation interventions. They should include range-of-motion (ROM), active therapies, and a home exercise program. Passive as well as active therapies may be used for control of pain and swelling. Therapy should progress to strengthening and an independent home exercise program targeted to further improve ROM and strength of the shoulder girdle musculature. (Refer to Therapeutic Procedures, Non-operative.)

iv. Subacromial bursal and/or glenohumeral steroid injections may decrease inflammation and allow the therapist to progress with functional exercise and ROM.

(a). Time to Produce Effect: One injection.

(b). Maximum Duration: Three injections in one year at least four to eight weeks apart.

(c). Steroid injections should be used cautiously in diabetic patients. Diabetic patients should be reminded to check their blood glucose levels at least daily for two weeks after injections.

v. Return to work with appropriate restrictions should be considered early in the course of treatment. Refer to Return to Work.

vi. Other therapies in Therapeutic Procedures, Non-operative may be employed in individual cases.

f. Surgical Indications: There is a significant amount of normal anatomic variation of the superior glenoid labrum and origin of the long head of the biceps tendon. Differentiation between normal variation and pathology is imperative.

i. The physician should identify other shoulder pathology if any exists and follow the appropriate surgical indications. If a SLAP lesion is suspected, an arthroscopic exam should be performed in conjunction with the primary surgical procedure and an appropriate repair performed if necessary. See Specific Diagnosis Testing, & Treatment related sections. Or;

ii. When no additional pathology is identified and there is an inadequate response to at least three months of non-operative management with active patient participation as evidenced by continued pain with functional limitations

and/or instability significantly affecting activities of daily living or work duties;

iii. Prior to surgical intervention, the patient and treating physician should identify functional operative goals and the likelihood of achieving improved ability to perform activities of daily living or work activities and the patient should agree to comply with the pre- and post-operative treatment plan and home exercise requirements. The patient should understand the length of partial and full disability expected post-operatively. The patient should also understand that non-operative treatment is an acceptable option and that a potential complication of the surgery is shoulder stiffness with pain and possibly decreased function.

g. Operative Procedures: Operative treatment of SLAP lesions depends on the type of lesion present and whether any other intra-articular abnormalities are present. The following are generally accepted protocols for surgical intervention; however, due to current lack of evidence, operative treatment is not limited to these.

i. TypeI: Debridement is reasonable but not required.

ii. TypeII: Repair via suture anchors or biceps tenotomy are reasonable options.

iii. TypeIII: Debridement or excision of the bucket handle component alone or repair via suture anchors or biceps tenotomy/tenodesis are reasonable options.

iv. TypeIV: Debridement and/or biceps tenotomy or tenodesis are reasonable options.

h. Post-Operative Treatment: Post-Operative rehabilitation programs should be individualized and dependent upon whether any other intra-articular abnormalities exist and were operatively treated. There is a paucity of information on rehabilitation of isolated SLAP lesions. Common post-operative care involves wearing a sling, without active shoulder motion for 4 to 6 weeks. Elbow, wrist, and hand range-of-motion (ROM) exercises may be used at this time. The sling is removed at 4 to 6 weeks and active ROM is usually begun with restrictions directed by the surgeon. It is reasonable to restrict external rotation and abduction up to six months post-operative. Return to work and restrictions after surgery may be made by an experienced primary occupational medicine physician in consultation with the surgeon or by the surgeon.

AUTHORITY NOTE: Promulgated in accordance with R.S. 23:1203.1.

HISTORICAL NOTE: Promulgated by the Louisiana Workforce Commission, Office of Workers Compensation Administration, LR 37:1828 (June 2011), amended LR 49:523 (March 2023).

### **§2325. Therapeutic Procedures—Non-Operative**

A. Treating providers, as well as employers and insurers are highly encouraged to reference the General Guideline Principles. Before initiation of any therapeutic procedure, the authorized treating provider, employer, and insurer must consider these important issues in the care of the injured worker.

B. First, patients undergoing therapeutic procedure(s) should be released or returned to modified or restricted duty during their rehabilitation at the earliest appropriate time. Refer to “Return-to-Work” in this section for detailed information.

C. Second, cessation and/or review of treatment modalities should be undertaken when no further significant subjective or objective improvement in the patient’s condition is noted. If patients are not responding within the recommended duration periods, alternative treatment interventions, further diagnostic studies or consultations should be pursued.

D. Third, providers should provide and document education to the patient. No treatment plan is complete without addressing issues of individual and/or group patient education as a means of facilitating self-management of symptoms.

E. Lastly, formal psychological or psychosocial evaluation should be performed on patients not making expected progress within 6 to 12 weeks following injury and whose subjective symptoms do not correlate with objective signs and tests.

F. In cases where a patient is unable to attend an outpatient center, skilled home therapy may be necessary. Skilled home therapy may include active and passive therapeutic procedures as well as other modalities to assist in alleviating pain, swelling, and abnormal muscle tone. Skilled home therapy is usually of short duration and continues until the patient is able to tolerate coming to an outpatient center.

1. Acupuncture is an accepted and widely used procedure for the relief of pain and inflammation, and there is some scientific evidence to support its use. The exact mode of action is only partially understood. Western medicine literature suggests that acupuncture stimulates the nervous system at the level of the brain, promotes deep relaxation, and affects the release of neurotransmitters. Acupuncture is commonly used as an alternative or in addition to traditional Western pharmaceuticals. While it is commonly used when pain medication is reduced or not tolerated, it may be used as an adjunct to physical rehabilitation and/or surgical intervention to hasten the return to functional activity. Acupuncture should be performed by licensed practitioners.

a. Acupuncture is the insertion and removal of filiform needles to stimulate acupoints (acupuncture points). Needles may be inserted, manipulated, and retained for a period of time. Acupuncture can be used to reduce pain, reduce inflammation, increase blood flow, increase range of motion, decrease the side effect of medication-induced nausea, promote relaxation in an anxious patient, and reduce muscle spasm.

i. Indications include joint pain, joint stiffness, soft tissue pain and inflammation, paresthesia, post-surgical pain relief, muscle spasm, and scar tissue pain.

b. Acupuncture with Electrical Stimulation: is the use of electrical current (micro-amperage or milli-amperage)

on the needles at the acupuncture site. It is used to increase effectiveness of the needles by continuous stimulation of the acupoint. Physiological effects (depending on location and settings) can include endorphin release for pain relief, reduction of inflammation, increased blood circulation, analgesia through interruption of pain stimulus, and muscle relaxation. It is indicated to treat chronic pain conditions, radiating pain along a nerve pathway, muscle spasm, inflammation, scar tissue pain, and pain located in multiple sites.

c. Total Time Frames for Acupuncture and Acupuncture with Electrical Stimulation: Time frames are not meant to be applied to each of the above sections separately. The time frames are to be applied to all acupuncture treatments regardless of the type or combination of therapies being provided.

- i. Time to Produce Effect: three to ix treatments.
- ii. Frequency: one to three times per week.
- iii. Optimum Duration: one to two months.
- iv. Maximum Duration: 14 treatments.

(a). Any of the above acupuncture treatments may extend longer if objective functional gains can be documented or when symptomatic benefits facilitate progression in the patient's treatment program. Treatment beyond 14 treatments must be documented with respect to need and ability to facilitate positive symptomatic or functional gains. Such care should be re-evaluated and documented with each series of treatments.

d. Other Acupuncture Modalities: Acupuncture treatment is based on individual patient needs and therefore treatment may include a combination of procedures to enhance treatment effect. Other procedures may include the use of heat, soft tissue manipulation/massage, and exercise. Refer to Active Therapy (Therapeutic Exercise) and Passive Therapy sections (Massage and Superficial Heat and Cold Therapy) for a description of these adjunctive acupuncture modalities and time frames.

2. Biofeedback is a form of behavioral medicine that helps patients learn self-awareness and self-regulation skills for the purpose of gaining greater control of their physiology, such as muscle activity, brain waves, and measures of autonomic nervous system activity. Electronic instrumentation is used to monitor the targeted physiology and then displayed or fed back to the patient visually, auditorily, or tactilely, with coaching by a biofeedback specialist. Biofeedback is provided by clinicians certified in biofeedback and/or who have documented specialized education, advanced training, or direct or supervised experience qualifying them to provide the specialized treatment needed (e.g., surface EMG, EEG, or other).

a. Treatment is individualized to the patient's work-related diagnosis and needs. Home practice of skills is required for mastery and may be facilitated by the use of home training tapes. The ultimate goal in biofeedback treatment is normalizing the physiology to the pre-injury

status to the extent possible and involves transfer of learned skills to the workplace and daily life. Candidates for biofeedback therapy or training must be motivated to learn and practice biofeedback and self-regulation techniques.

b. Indications for biofeedback include individuals who are suffering from musculoskeletal injury in which muscle dysfunction or other physiological indicators of excessive or prolonged stress response affects and/or delays recovery. Other applications include training to improve self-management of emotional stress/pain responses such as anxiety, depression, anger, sleep disturbance, and other central and autonomic nervous system imbalances. Biofeedback is often utilized along with other treatment modalities.

- i. Time to Produce Effect: three to four sessions.
- ii. Frequency: One to two times per week.
- iii. Optimum Duration: Five to six sessions.

iv. Maximum Duration: 10 to 12 sessions. Treatment beyond 12 sessions must be documented with respect to need, expectation, and ability to facilitate positive symptomatic or functional gains.

3. Extracorporeal Shock Wave Therapy (ESWT) is used to increase function and decrease pain in patients with specified types of calcifying tendonitis who have failed conservative therapy. It is not a first line therapy. ESWT uses acoustic impulses with duration in microseconds focused on the target tissue. The mechanism of action is not known, but is not likely to be simply the mechanical disintegration of the calcium deposit. High-energy application of ESWT may be painful, and rare complications such as osteonecrosis of the humeral head have been reported. Dosage is established according to patient tolerance. Higher dosages are generally associated with better functional results. There is good evidence that ESWT may improve pain and function in radiographically or sonographically defined Type I or Type II calcium deposits when conservative treatment has failed to result in adequate functional improvement, but optimal dosing has not been defined. In the absence of a documented calcium deposit, there is no evidence that ESWT is effective and its use in this setting is not recommended. Neither anesthesia nor conscious sedation is required nor is it recommended for this procedure. There is no evidence that results with fluoroscopic guidance or with computer-assisted navigation are superior to results obtained by palpation. These are not recommended.

a. Indications—patients with calcifying tendonitis who have not achieved functional goals after two to three months of active therapy. The calcium deposits must be Type I, homogenous calcification with well-defined borders or Type II, heterogeneous with sharp border or homogenous with no defined border.

- i. Time to Produce Effect: Three days.
- ii. Frequency: Every four to seven days.

iii. Optimum Duration: Two sessions. Progress can be documented by functional reports and/or x-ray or sonographic decrease in calcium.

iv. Maximum Duration: Four sessions.

#### 4. Injections-Therapeutic

a. Description. Therapeutic injection procedures are generally accepted, well-established procedures that may play a significant role in the treatment of patients with upper extremity pain or pathology. Therapeutic injections involve the delivery of anesthetic and/or anti-inflammatory medications to the painful structure. Therapeutic injections have many potential benefits. Ideally, a therapeutic injection will: reduce inflammation in a specific target area; relieve secondary muscle spasm; allow a break from pain; and support therapy directed to functional recovery. Diagnostic and therapeutic injections should be used early and selectively to establish a diagnosis and support rehabilitation. If injections are overused or used outside the context of a monitored rehabilitation program, they may be of significantly less value.

b. Indications. Diagnostic injections are procedures which may be used to identify pain generators or pathology. For additional specific clinical indications, see Specific Diagnosis, Testing and Treatment Procedures.

c. Contraindications - General contraindications include local or systemic infection, bleeding disorders, allergy to medications used and patient refusal. Specific contraindications may apply to individual injections.

i. Shoulder Joint Injections: are generally accepted, well-established procedures that can be performed as analgesic or anti-inflammatory procedures. Common shoulder joint injections include anterior and posterior glenohumeral and acromioclavicular.

(a). Time to Produce Effect: Immediate with local anesthesia, or within 3 days if no anesthesia.

(b). Optimum Duration: Usually One or two injections are adequate.

(c). Maximum Duration: Not more than three to four times annually.

(d). Steroid injections should be used cautiously in diabetic patients. Diabetic patients should be reminded to check their blood glucose level at least daily for two weeks post injections.

ii. Subacromial Injections There is good evidence that blinded subacromial blocks are not accurate. Up to a third of blinded injections may involve the cuff and are likely to cause pain. This may lead to an incorrect diagnosis when the injection is being used diagnostically. (Refer to Diagnostic injections) If there is a concern regarding needle placement, sonography or fluoroscopy may be used.

iii. Soft Tissue Injections: include bursa and tendon insertions. Injections under significant pressure should be avoided as the needle may be penetrating the tendon. Injection into the tendon can cause tendon

degeneration, tendon breakdown, or rupture. Injections should be minimized for patients under 30 years of age. Steroid injections should be used cautiously in diabetic patients. Diabetic patients should be reminded to check their blood glucose level at least daily for two weeks post injections. The risk of tendon rupture should be discussed with the patient and the need for restricted duty emphasized.

(a). Frequency: Usually one or two injections are adequate.

(b). Time to Produce Effect: Immediate with local anesthesia, or within three days if no anesthesia.

(c). Optimum/Maximum Duration: Three steroid injections at the same site per year.

iv. Trigger Point Injections: although generally accepted, are not routinely used in the shoulder. However, it is not unusual to find shoulder girdle myofascial trigger points associated with shoulder pathology which may require injections.

(a). Description. Trigger point treatment can consist of dry needling or injection of local anesthetic with or without corticosteroid into highly localized, extremely sensitive bands of skeletal muscle fibers that produce local and referred pain when activated. Medication is injected in a four-quadrant manner in the area of maximum tenderness. Injection efficacy can be enhanced if injections are immediately followed by myofascial therapeutic interventions, such as vapo-coolant spray and stretch, ischemic pressure massage (myotherapy), specific soft tissue mobilization and physical modalities. There is conflicting evidence regarding the benefit of trigger point injections. A truly blinded study comparing dry needle treatment of trigger points is not feasible. There is no evidence that injection of medications improves the results of trigger-point injections. Needling alone may account for some of the therapeutic response.

(i). There is no indication for conscious sedation for patients receiving trigger point injections. The patient must be alert to help identify the site of the injection.

(b). Indications. Trigger point injections may be used to relieve myofascial pain and facilitate active therapy and stretching of the affected areas. They are to be used as an adjunctive treatment in combination with other treatment modalities such as functional restoration programs. Trigger point injections should be utilized primarily for the purpose of facilitating functional progress. Patients should continue with a therapeutic exercise program as tolerated throughout the time period they are undergoing intensive myofascial interventions. Myofascial pain is often associated with other underlying structural problems and any abnormalities need to be ruled out prior to injection.

(i). Trigger point injections are indicated in those patients where well circumscribed trigger points have been consistently observed, demonstrating a local twitch response, characteristic radiation of pain pattern and local autonomic reaction, such as persistent hyperemia following palpation. Generally, these injections are not necessary

unless consistently observed trigger points are not responding to specific, noninvasive, myofascial interventions within approximately a 6-week time frame.

(ii). Complications. Potential but rare complications of trigger point injections include infection, pneumothorax, anaphylaxis, neurapraxia, and neuropathy. If corticosteroids are injected in addition to local anesthetic, there is a risk of local developing myopathy. Severe pain on injection suggests the possibility of an intraneural injection, and the needle should be immediately repositioned.

[a]. Time to Produce Effect: Local anesthetic 30 minutes; no anesthesia 24 to 48 hours.

[b]. Frequency: Weekly, suggest no more than four injection sites per session per week to avoid significant post-injection soreness.

[c]. Optimum Duration: Four Weeks.

[d]. Maximum Duration: Eight weeks. Occasional patients may require two to four repetitions of trigger point injection series over a one to two year period.

v. Prolotherapy: (also known as Sclerotherapy/Regenerative Injection Therapy) consists of peri- or intra-ligamentous injections of hypertonic dextrose with or without phenol with the goal of inducing an inflammatory response that will recruit cytokine growth factors involved in the proliferation of connective tissue. Advocates of prolotherapy propose that these injections will alleviate complaints related to joint laxity by promoting the growth of connective tissue and stabilizing the involved joint.

(a). Laboratory studies may lend some biological plausibility to claims of connective tissue growth, but high quality published clinical studies are lacking. The dependence of the therapeutic effect on the inflammatory response is poorly defined, raising concerns about the use of conventional anti-inflammatory drugs when proliferant injections are given. The evidence in support of prolotherapy is insufficient and therefore, its use is not recommended in upper extremity injuries.

vi. Viscosupplementation/Intracapsular Acid Salts: involves the injection of hyaluronic acid and its derivatives into the glenohumeral joint space. Hyaluronic acid is secreted into the joint space by the healthy synovium and has functions of lubrication and cartilage protection. Its use in the shoulder is not supported by scientific evidence at this time.

5. Jobsite Alteration. Early evaluation and training of body mechanics are essential for every injured worker. Risk factors to be addressed include repetitive overhead work, lifting and/or tool use. In some cases, this requires a jobsite evaluation. Some evidence supports alteration of the work site in the early treatment of shoulder injuries. There is no single factor or combination of factors that is proven to prevent or ameliorate shoulder pain, but a combination of ergonomic and psychosocial factors are generally considered to be important. Physical factors that may be considered

include use of force, repetitive overhead work, and awkward overhead positions requiring use of force, upper extremity vibration, and contact pressure on the nerve. Psychosocial factors to be considered include pacing, degree of control over job duties, perception of job stress, and supervisory support. The job analysis and modification should include input from the employee, employer, and ergonomist or other professional familiar with work place evaluation. The employee must be observed performing all job functions in order for the jobsite analysis to be valid. Periodic follow-up is recommended to evaluate effectiveness of the intervention and need for additional ergonomic changes.

a. Ergonomic Changes may be made to modify the hazards identified. In addition, workers should be counseled to vary tasks throughout the day whenever possible. OSHA suggests that workers' who perform overhead repetitive tasks with or without force, take 15 to 30 second breaks every 10 to 20 minutes, or 5-minute breaks every hour. Mini-breaks should include stretching exercises.

b. Interventions should consider engineering controls (e.g., mechanizing the task, changing the tool used, or adjusting the jobsite), or administrative controls (e.g., adjusting the time an individual performs the task).

6. Medications for the treatment of upper extremity injuries is appropriate to control acute pain and inflammation. Use of medications will vary widely due to the spectrum of injuries from simple strains to complicated fractures. All drugs should be used according to patient needs. A thorough medication history, including use of alternative and over the counter medications, should be performed at the time of the initial visit and updated periodically. Treatment for pain control is initially accomplished with acetaminophen and/or NSAIDs. The patient should be educated regarding the interaction with prescription and over-the-counter medications as well as the contents of over-the-counter herbal products.

a. Nonsteroidal anti-inflammatory drugs (NSAIDs) and acetaminophen are useful in the treatment of injuries associated with degenerative joint disease and/or inflammation. These same medications can be used for pain control.

b. Topical agents may be beneficial for pain management in some patients with upper extremity injuries. This includes topical capsaicin, nonsteroidal, as well as, topical iontophoresis/phonophoresis, such as steroid creams and lidocaine.

c. The following are listed in alphabetical order.

i. Acetaminophen is an effective analgesic with antipyretic but not anti-inflammatory activity. Acetaminophen is generally well tolerated, causes little or no gastrointestinal irritation and is not associated with ulcer formation. Acetaminophen has been associated with liver toxicity in overdose situations or in chronic alcohol use. Patients may not realize that many over-the-counter preparations may contain acetaminophen. The total daily dose of acetaminophen is recommended not to exceed 2250



mg per 24 hour period, from all sources, including narcotic-acetaminophen combination preparations.

(a). Optimum Duration: 7 to 10 days.

(b). Maximum Duration: Chronic use as indicated on a case-by-case basis. Use of this substance long-term for three days per week or greater may be associated with rebound pain upon cessation.

ii. Minor Tranquilizer/Muscle Relaxants are appropriate for muscle spasm, mild pain and sleep disorders. When prescribing these agents, physicians must seriously consider side effects of drowsiness or dizziness and the fact that benzodiazepines may be habit-forming.

(a). Optimum Duration: Up to one week.

(b). Maximum Duration: Four weeks.

iii. Narcotics should be primarily reserved for the treatment of severe upper extremity pain. There are circumstances where prolonged use of narcotics is justified based upon specific diagnosis and in pre- and post-operative patients. In these and other cases, it should be documented and justified. In mild-to-moderate cases of upper extremity pain, narcotic medication should be used cautiously on a case-by-case basis. Adverse effects include respiratory depression, the development of physical and psychological dependence, and impaired alertness.

(a). Narcotic medications should be prescribed with strict time, quantity, and duration guidelines, and with definitive cessation parameters. Pain is subjective in nature and should be evaluated using a pain scale and assessment of function to rate effectiveness of the narcotic prescribed. Any use beyond the maximum should be documented and justified based on the diagnosis and/or invasive procedures.

(i). Optimum Duration: Up to 10 days.

(ii). Maximum Duration: Two weeks for most non-operative cases. Use beyond two weeks is acceptable in appropriate cases. Refer to Chronic Pain Guidelines which provides a detailed discussion regarding medication use in chronic pain management.

iv. Nonsteroidal Anti-Inflammatory Drugs (NSAIDs) are useful for pain and inflammation. In mild cases, they may be the only drugs required for analgesia. There are several classes of NSAIDs, and the response of the individual injured worker to a specific medication is unpredictable. For this reason, a range of NSAIDs may be tried in each case with the most effective preparation being continued. Patients should be closely monitored for adverse reactions. The US Food and Drug Administration advises that many NSAIDs may cause an increased risk of serious cardiovascular thrombotic events, myocardial infarction, and stroke, which can be fatal. Naproxen sodium does not appear to be associated with increased risk of vascular events. Administration of proton pump inhibitors, Histamine 2 Blockers, or prostaglandin analog misoprostol along with these NSAIDs may reduce the risk of duodenal and gastric ulceration but do not impact possible cardiovascular complications. Due to the cross-reactivity between aspirin

and NSAIDs, NSAIDs should not be used in aspirin-sensitive patients, and should be used with caution in all asthma patients. NSAIDs are associated with abnormal renal function, including renal failure, as well as, abnormal liver function. Certain NSAIDs may have interactions with various other medications. Individuals may have adverse events not listed above. Intervals for metabolic screening are dependent upon the patient's age, general health status and should be within parameters listed for each specific medication. Complete Blood Count (CBC) and liver and renal function should be monitored at least every six months in patients on chronic NSAIDs and initially when indicated.

(a). Non-selective Nonsteroidal Anti-Inflammatory Drugs:

(i). Includes NSAIDs, and acetylsalicylic acid (aspirin). Serious GI toxicity, such as bleeding, perforation, and ulceration can occur at any time, with or without warning symptoms in patients treated with traditional NSAIDs. Physicians should inform patients about the signs and/or symptoms of serious gastrointestinal toxicity and what steps to take if they occur. Anaphylactoid reactions may occur in patients taking NSAIDs. NSAIDs may interfere with platelet function. Fluid retention and edema have been observed in some patients taking NSAIDs.

[a]. Optimal Duration: One week.

[b]. Maximum Duration: One year. Use of these substances long-term (Three days per week or greater) is associated with rebound pain upon cessation.

(b). Selective Cyclo-oxygenase-2 (COX-2) Inhibitors:

(i). COX-2 inhibitors are more recent NSAIDs and differ in adverse side effect profiles from the traditional NSAIDs. The major advantages of selective COX-2 inhibitors over traditional NSAIDs are that they have less gastrointestinal toxicity and no platelet effects. COX-2 inhibitors can worsen renal function in patients with renal insufficiency, thus renal function may need monitoring.

(ii). COX-2 inhibitors should not be first-line for low risk patients who will be using an NSAID short term but are indicated in select patients for whom traditional NSAIDs are not tolerated. Serious upper GI adverse events can occur even in asymptomatic patients. Patients at high risk for GI bleed include those who use alcohol, smoke, are older than 65, take corticosteroids or anti-coagulants, or have a longer duration of therapy. Celecoxib is contraindicated in sulfonamide allergic patients.

[a]. Optimal Duration: 7 to 10 days.

[b]. Maximum Duration: Chronic use is appropriate in individual cases. Use of these substances long-term (three days per week or greater) is associated with rebound pain upon cessation.

v. Oral Steroids: have limited use but are accepted in cases requiring potent anti-inflammatory drug effect in carefully selected patients. A one-week regime of steroids may be considered in the treatment of patients who

have arthritic flare-ups with significant inflammation of the joint. The physician must be fully aware of potential contraindications for the use of all steroids such as avascular necrosis, hypertension, diabetes, glaucoma, peptic ulcer disease, etc., which should be discussed with the patient.

(a). Optimal Duration: Three to seven days.

(b). Maximum Duration: Seven days.

vi. Psychotropic/Anti-anxiety/Hypnotic Agents: may be useful for treatment of mild and chronic pain, dysesthesia, sleep disorders, and depression. Antidepressant medications, such as tricyclics and Selective Serotonin Reuptake inhibitors (SSRIs) and Selective serotonin norepinephrine reuptake inhibitors (SSNRIs), are useful for affective disorder and chronic pain management. Tricyclic antidepressant agents, in low dose, are useful for chronic pain but have more frequent side effects.

(a). Anti-anxiety medications are best used for short-term treatment (i.e., less than six months). Accompanying sleep disorders are best treated with sedating antidepressants prior to bedtime. Frequently, combinations of the above agents are useful. As a general rule, physicians should access the patient's prior history of substance abuse or depression prior to prescribing any of these agents.

(b). Due to the habit-forming potential of the benzodiazepines and other drugs found in this class, they are not routinely recommended. Refer to the Chronic Pain Guidelines which give a detailed discussion regarding medication use in chronic pain management.

(i). Optimum Duration: One to six months.

(ii). Maximum Duration: 6 to 12 months, with monitoring.

vii. Tramadol is useful in relief of upper extremity pain and has been shown to provide pain relief equivalent to that of commonly prescribed NSAIDs. Tramadol is an atypical opioid with norepinephrine and serotonin reuptake inhibition. It is not considered a controlled substance in the U.S. Although tramadol may cause impaired alertness it is generally well tolerated, does not cause gastrointestinal ulceration, or exacerbate hypertension or congestive heart failure. Tramadol should be used cautiously in patients who have a history of seizures or who are taking medication that may lower the seizure threshold, such as MAO inhibitors, SSRIs, and tricyclic antidepressants. This medication has physically addictive properties and withdrawal may follow abrupt discontinuation and is not recommended for patients with prior opioid addiction.

(a). Optimum Duration: Three to seven days.

(b). Maximum Duration: Two weeks. Use beyond two weeks is acceptable in appropriate cases.

#### viii. Topical Drug Delivery

(a). Description. Topical creams and patches may be an alternative treatment of localized musculoskeletal and neuropathic disorders and can be especially helpful in avoiding opioid use.

(b). Indications: neuropathic pain for many agents; episodic use of NSAIDs and salicylates for joint pain or musculoskeletal disorders. All topical agents should be used with strict instructions for application as well as maximum number of applications per day to obtain the desired benefit and avoid potential toxicity.

(c). Dosing and time to therapeutic effect: all topical agents should be prescribed with clear instructions for application and maximum number of applications per day to obtain the desired benefit and avoid potential toxicity. For most patients, the effects of long-term use are unknown. Thus, episodic use may be preferred for some agents.

(d). Side Effects. localized skin reactions may occur, depending on the medication agent used.

#### (e). Topical Agents

(i). Capsaicin. As of the time of this guideline writing, formulations of capsaicin have been FDA approved for management of pain associated with post-herpetic neuralgia. Capsaicin offers a safe and effective alternative to systemic NSAID therapy. Although it is quite safe, the local stinging or burning sensation that typically dissipates with regular use, usually after the first 7 to 10 days of treatment, limits effective use of capsaicin. Patients should be advised to apply the cream on the affected area with a plastic glove or cotton applicator and to avoid inadvertent contact with eyes and mucous membranes.

[a]. There is good evidence that low dose capsaicin (0.075 percent) applied four times per day will decrease pain up to 50 percent. There is strong evidence that a single application of eight percent capsaicin is more effective than a control preparation of 0.04 percent capsaicin for up to 12 weeks. However, there may be a need for frequent application, and it is not known whether subsequent applications of capsaicin are likely to be as effective as the first application. There is some evidence that in patients who are being treated with capsaicin 8 percent patches, two methods of pre-treatment are equally effective in controlling application pain and in enabling patients to tolerate the patch: topical four percent lidocaine cream applied to the area for one hour before placement of the capsaicin patch and 50 mg oral tramadol taken 30 minutes before patch placement.

(ii). Clonidine. There is good evidence that topical clonidine gel 0.1 percent is likely to alleviate pain from diabetic peripheral neuropathy in patients who display a nociceptive response to the application of 0.1 percent capsaicin applied to the pretibial area. It is likely that patients who do not display a pain response to pretibial capsaicin are not likely to have a clinically meaningful analgesic response to clonidine gel. It is unknown if this screening test applies to other types of neuropathic pain. Clonidine gel may be used for neuropathic pain.

[a]. Lofexidine (Lucemyra) is now available and indicated for mitigation of opioid withdrawal symptoms to facilitate abrupt discontinuation in adults. This is necessary to block or reduce life threatening side effects of

opioid withdrawal. This drug will be beneficial in drug treatment centers and for physicians finding necessity to abruptly stop opioid medication.

(iii). Ketamine and Tricyclics. Topical medications, such as the combination of ketamine and amitriptyline, have been proposed as an alternative treatment for neuropathic disorders including CRPS. A study using a 10 percent concentration showed no signs of systemic absorption. This low-quality study demonstrated decreased allodynia at 30 minutes for some CRPS patients. However, as of the time of this guideline writing, neither tricyclic nor ketamine topicals are FDA approved for topical use in neuropathic pain. Furthermore, there is good evidence that neither two percent topical amitriptyline nor 1 percent topical ketamine reduces neuropathic pain syndromes. Despite the lack of evidence, it is physiologically possible that topical tricyclics and a higher dose of ketamine could have some effect on neuropathic pain. Other less expensive topicals and compounds, including over-the-counter, should be trialed before more expensive compounds are ordered. The use of topical tricyclics and/or ketamine should be limited to patients with neuritic and/or sympathetically mediated pain with documented supporting objective findings such as allodynia and/or hyperalgesia. Continued use of these agents beyond the initial prescription requires documentation of effectiveness, including functional improvement, and/or decreased use of other medications, particularly decreased use of opioids or other habituating medications.

(iv). Lidocaine. As of the time of this guideline writing, formulations of lidocaine (patch form) have been FDA approved for pain associated with post-herpetic neuralgia. Evidence is mixed for long-term use of lidocaine topically. Physicians should always take into account the blood level that may be achieved with topical use as toxic levels have been reported and there is variability and systemic absorption among individuals. There is good evidence that lidocaine five percent plasters, applied for up to 12 hours to the lower extremities of patients with post-herpetic neuralgia and diabetic painful neuropathy, is non-inferior to pregabalin for the same indications. The topical lidocaine is associated with significantly fewer drug-related adverse events over four weeks of observation. There is some evidence that a five percent lidocaine patch may be used as a secondary option for patients with focal neuropathic pain. A 30 to 50 percent pain reduction may be achieved in those who tolerate the patch. Up to three patches may be used simultaneously for 12 hours per day. It should be applied only to intact skin. Metered dose eight percent pump sprays have also been used and usually require a three times per day reapplication. There is some evidence that the eight percent sprays are effective for short-term, two-week use. However, the effects of long-term use are unknown.

(v). Topical Salicylates and Nonsalicylates have been shown to be effective in relieving pain in acute musculoskeletal conditions and single joint osteoarthritis. Topical salicylate and nonsalicylates achieve tissue levels

that are potentially therapeutic, at least with regard to COX inhibition.

[a]. There is insufficient evidence to support the use of topical rubefacients containing salicylates for acute injuries or chronic conditions. They seem to be relatively well tolerated in the short-term, based on limited data. The amount and quality of the available data mean that uncertainty remains about the effects of salicylate-containing rubefacients.

[b]. There is good evidence that diclofenac gel (Voltaren, Solaraze) reduces pain and improves function in mild-to-moderate hand osteoarthritis. There is good evidence that topical diclofenac and ketoprofen are more effective than placebo preparations for purposes of relieving pain attributable to knee osteoarthritis. There is good evidence that topical NSAIDs probably reduce the risk of GI adverse effects by approximately one-third compared to oral NSAIDs. Topical diclofenac does not appear to affect the anti-platelet properties of aspirin unlike the oral version. The topical solution of two percent sodium diclofenac applied thrice a day is equal to 1.5 percent four times per day.

[c]. Diclofenac gel has been FDA approved for acute pain due to minor strains, pains, and contusions and for relief of pain due to osteoarthritis of the joints amenable to topical treatment, such as those of the knees, shoulders, and hands. It is likely that other NSAIDs would also be effective topically. Thus, topical NSAIDs are permitted when patients show functional improvement.

[d]. Other than local skin reactions, the side effects of therapy are minimal, although not non-existent. The usual contraindications to use of these compounds needs to be considered. Local skin reactions are rare and systemic effects are even less common. Their use in patients receiving warfarin therapy may result in alterations in bleeding time. Overall, the low level of systemic absorption can be advantageous. This allows the topical use of these medications when systemic administration is relatively contraindicated, such as is the case in patients with hypertension, cardiac failure, or renal insufficiency. Both topical salicylates and NSAIDs are appropriate for many chronic pain patients. However, in order to receive refills, patients should demonstrate increased function, decreased pain, or decreased need for oral medications.

(vi). Other Compounded Topical Agents. At the time of writing this guideline, no studies identified evidence for the effectiveness of compounded topical agents other than those recommended above. Therefore, other compounded topical agents are not generally recommended. In rare cases, they may be appropriate for patients who prefer a topical medication to chronic opioids or who have allergies or side effects from other more commonly used oral agents.

(vii). Prior authorization is required for all agents that have not been recommended above.

ix. Other Agents

(a). Glucosamine. There is good evidence that glucosamine does not improve pain related disability in those with chronic low back pain and degenerative changes on radiologic studies; therefore, it is not recommended for chronic lower spinal or non-joint pain. For chronic pain related to joint osteoarthritis, see specific extremity guidelines. Glucosamine should not be combined with chondroitin as it is ineffective.

(b). Oral Herbals. There is insufficient evidence due to low quality studies that an oral herbal medication, Compound Qishe Tablet, reduced pain more than placebo. There is also insufficient evidence that Jingfukang and a topical herbal medicine, Compound Extractum Nucis Vomicae, reduced pain more than Diclofenac Diethylamine Emulgel. Further research is very likely to change both the effect size and our confidence in the results. Currently, no oral herbals are recommended.

(c). Vitamin D. A large beneficial effect of vitamin D across different chronic painful conditions is unlikely. Therefore, it is not recommended.

(d). Alpha-Lipoic Acid. An adequate meta-analysis shows that there is some evidence that alpha-lipoic acid at a dose of 600 mg per day may reduce the symptoms of painful diabetic neuropathy in the short term of three to five weeks. The effect of the intravenous route appears to be greater than that of the oral route, but the oral route may have a clinically relevant effect. Doses of 1200 or 1800 mg have not been shown to have additional therapeutic benefit. This medication may be used for neuropathic pain.

## 7. Occupational Rehabilitation Programs

a. Non-Interdisciplinary. These generally accepted programs are work-related, outcome-focused, individualized treatment programs. Objectives of the program include, but are not limited to, improvement of cardiopulmonary and neuromusculoskeletal functions (strength, endurance, movement, flexibility, stability, and motor control functions), patient education, and symptom relief. The goal is for patients to gain full or optimal function and return to work. The service may include the time-limited use of passive modalities with progression to achieve treatment and/or simulated/real work. These programs are frequently necessary for patients who must return to physically demanding job duties or whose injury requires prolonged rehabilitation and therapy spanning several months.

i. Work Conditioning. These programs are usually initiated once reconditioning has been completed, but may be offered at any time throughout the recovery phase. It should be initiated when imminent return of a patient to modified or full duty is not an option, but the prognosis for returning the patient to work at completion of the program is at least fair to good.

- (a). Length of visit: One to two hours per day.
- (b). Frequency: Two to five visits per week.
- (c). Optimum Duration: Two to five weeks.

(d). Maximum Duration: Six weeks. Participation in a program beyond six weeks must be documented with respect to need and the ability to facilitate positive symptomatic or functional gains.

ii. Work Simulation. Work Simulation is a program where an individual completes specific work-related tasks for a particular job and return to work. Use of this program is appropriate when modified duty can only be partially accommodated in the work place, when modified duty in the work place is unavailable, or when the patient requires more structured supervision. The need for work place simulation should be based upon the results of a Functional Capacity Evaluation and/or Jobsite Analysis.

- (a). Length of visit: Two to six hours per day.
- (b). Frequency: Two to five visits per week.
- (c). Optimum Duration: Two to four weeks.

(d). Maximum Duration. Six weeks. Participation in a program beyond six weeks must be documented with respect to need and the ability to facilitate positive symptomatic or functional gains.

b. Interdisciplinary. These generally accepted programs are characterized by a variety of disciplines that participate in the assessment, planning, and/or implementation of an injured workers program with the goal for patients to gain full or optimal function and return to work. There should be close interaction and integration among the disciplines to ensure that all members of the team interact to achieve team goals. These programs are for patients with greater levels of perceived disability, dysfunction, de-conditioning and psychological involvement. For patients with chronic pain, refer to the OWCA's Chronic Pain Disorder Medical Treatment Guidelines.

i Work Hardening. Work Hardening is an interdisciplinary program addressing a patient's employability and return to work. It includes a progressive increase in the number of hours per day that a patient completes work simulation tasks until the patient can tolerate a full workday. This is accomplished by addressing the medical, psychological, behavioral, physical, functional, and vocational components of employability and return-to-work.

ii. This can include a highly structured program involving a team approach or can involve any of the components thereof. The interdisciplinary team should, at a minimum, be comprised of a qualified medical director who is board certified with documented training in occupational rehabilitation; team physicians having experience in occupational rehabilitation, occupational therapist; physical therapist; case manager; and psychologist. As appropriate, the team may also include: chiropractor, RN, or vocational specialist or Certified Biofeedback Therapist.

- (a). Length of visit: Up to eight hours/day.
- (b). Frequency: Two to five visits per week.

(c). Optimum Duration: Two to four weeks.

(d). Maximum Duration. Six weeks.

Participation in a program beyond six weeks must be documented with respect to need and the ability to facilitate positive symptomatic or functional gains.

#### 8. Orthotics and Prosthetics

a. Fabrication/Modification of Orthotics facilitate better motion response, stabilize a joint with insufficient muscle or proprioceptive/reflex competencies, to protect subacute conditions as needed during movement, and correct biomechanical problems. For specific types of orthotics/prosthetics, refer to Specific Diagnosis, Testing and Treatment Procedures.

i. Time to Produce Effect: One to three sessions (includes wearing schedule evaluation).

ii. Frequency: One to two times per week.

iii. Optimum/Maximum Duration: Four sessions of evaluation, casting, fitting, and re-evaluation.

b. Orthotic/Prosthetic Training is the skilled instruction (preferably by qualified providers) in the proper use of orthotic devices and/or prosthetic limbs including stump preparation, donning and doffing limbs, instruction in wearing schedule and orthotic/prosthetic maintenance training. Training can include activities of daily living and self-care techniques.

i. Time to Produce Effect: Two to six sessions.

ii. Frequency: Three times per week.

iii. Optimum/Maximum Duration: Two to four months.

c. Splints or adaptive equipment design, fabrication and/or modification indications include the need to control neurological and orthopedic injuries for reduced stress during functional activities and modify tasks through instruction in the use of a device or physical modification of a device, which reduces stress on the injury. Equipment should improve safety and reduce risk of re-injury. This includes high and low technology assistive options such as workplace modifications, computer interface or seating, and self-care aids.

i. Time to Produce Effect: Immediate.

ii. Frequency: One to three sessions or as indicated to establish independent use.

iii. Optimum/Maximum Duration: One to three sessions.

9. Patient Education. No treatment plan is complete without addressing issues of individual and/or group patient education as a means of prolonging the beneficial effects of treatment, as well as facilitating self-management of symptoms and injury prevention. The patient should be encouraged to take an active role in the establishment of functional outcome goals. They should be educated on their specific injury, assessment findings, and plan of treatment.

Instruction on proper body mechanics and posture, positions to avoid, self-care for exacerbation of symptoms, and home exercise should also be addressed.

a. Time to Produce Effect: Varies with individual patient.

b. Frequency: Should occur at each visit.

10. Personality/Psychosocial/Psychiatric/Psychological Intervention. Psychosocial treatment is generally accepted widely used and well-established intervention. This group of therapeutic and diagnostic modalities includes, but is not limited to, individual counseling, group therapy, stress management, psychosocial crises intervention, hypnosis and meditation. Any evaluation or diagnostic workup should clarify and distinguish between pre-existing versus aggravated versus purely causative psychological conditions. Psychosocial intervention is recommended as an important component in the total management program that should be implemented as soon as the problem is identified. This can be used alone or in conjunction with other treatment modalities. Providers treating patients with chronic pain should refer to the OWCA's Chronic Pain Disorder Medical Treatment Guidelines.

a. Time to Produce Effect: Two to four weeks.

b. Frequency: One to three times weekly for the first four weeks (excluding hospitalization, if required), decreasing to one to two times per week for the second month. Thereafter, two to four times monthly.

c. Optimum Duration: Six weeks to three months.

d. Maximum Duration. 3 to 12 months. Counseling is not intended to delay but to enhance functional recovery. For select patients, longer supervised treatment may be required, and if further counseling beyond 3 months is indicated, extensive documentation addressing which pertinent issues are pre-existing versus aggravated versus causative, as well as projecting a realistic functional prognosis, should be provided by the authorized treating provider every 4 to 6 weeks during treatment.

11. Restriction of Activities varies according to the specific diagnosis and the severity of the condition. Job modification/modified duty are frequently required to avoid exacerbation of the injured shoulder. Complete work cessation should be avoided, if possible, since it often further aggravates the pain presentation. Modified return-to-work is almost always more efficacious and rarely contraindicated in the vast majority of injured workers with upper extremity injuries.

12. Return-to-work. Early return-to-work should be a prime goal in treating occupational injuries given the poor return-to-work prognosis for an injured worker who has been out of work for more than six months. It is imperative that the patient be educated regarding the benefits of return-to-work, work restrictions, and follow-up if problems arise. When attempting to return a patient to work after a specific injury, clear objective restrictions of activity level should be made. An accurate job description with detailed physical

duty restrictions is often necessary to assist the physician in making return-to-work recommendations. This may require a jobsite evaluation.

a. Employers should be prepared to offer transitional work. This may consist of temporary work in a less demanding position, return to the regular job with restrictions, or gradual return to the regular job. Company policies which encourage return-to-work with positive communication are most likely to have decreased worker disability.

b. Return-to-work is defined as any work or duty that the patient is able to perform safely. It may not be the patient's regular work. Due to the large spectrum of injuries of varying severity and varying physical demands in the work place, it is not possible to make specific return-to-work guidelines for each injury. Therefore, the OWCA recommends the following:

i. Establishment of a Return-to-Work Status. Ascertain a return-to-work status is part of medical care, should be included in the treatment and rehabilitation plan, and addressed at every visit. A description of daily activity limitations is part of any treatment plan and should be the basis for restriction of work activities. In most non-surgical cases the patient should be able to return to work in some capacity or in an alternate position consistent with medical treatment within several days unless there are extenuating circumstances. Injuries requiring more than two weeks off work should be thoroughly documented. Refer to Specific Diagnoses in Post-Operative Return to Work Subsections.

ii. Establishment of Activity Level Restrictions. Communication is essential between the patient, employer and provider to determine appropriate restrictions and return-to-work dates. It is the responsibility of the physician to provide clear, concise restrictions, and it is the employer's responsibility to determine if temporary duties can be provided within the restrictions. For shoulder injuries, the following should be addressed when describing the patient's activity level:

(a). Activities such as overhead motion, lifting, abduction;

(b). Static shoulder positions with regard to duration and frequency;

(c). Use of adaptive devices or equipment for proper ergonomics and to enhance capacities;

(d). Maximum lifting limits with reference to the frequency of the lifting and/or the object height level; and

(e). Maximum limits for pushing, pulling, with limits on bending and twisting at the waist as necessary.

iii. Compliance with Activity Restrictions. In some cases, compliance with restriction of activity levels may require a complete jobsite evaluation, a functional capacity evaluation (FCE), or other special testing. Refer to "Special Tests" of this section.

### 13. Therapy-Active

a. The following active therapies are widely used and accepted methods of care for a variety of work-related injuries. They are based on the philosophy that therapeutic exercise and/or activity are beneficial for restoring flexibility, strength, endurance, function, range of motion, and can alleviate discomfort. Active therapy requires an internal effort by the individual to complete a specific exercise or task. This form of therapy requires supervision from a therapist or medical provider such as verbal, visual and/or tactile instruction(s). At times, the provider may help stabilize the patient or guide the movement pattern but the energy required to complete the task is predominately executed by the patient.

b. Patients should be instructed to continue active therapies at home as an extension of the treatment process in order to maintain improvement levels. Follow-up visits to reinforce and monitor progress and proper technique are recommended. Home exercise can include exercise with or without mechanical assistance or resistance and functional activities with assistive devices. Frequency times and duration of treatment apply only to diagnoses not previously covered in Section E.

i. Activities of Daily Living (ADL) are well-established interventions which involve instruction, active-assisted training, and/or adaptation of activities or equipment to improve a person's capacity in normal daily activities such as self-care, work re-integration training, homemaking, and driving.

(a). Time to Produce Effect: Four to five treatments.

(b). Frequency: Three to five times per week.

(c). Optimum Duration: Four to six weeks.

(d). Maximum Duration: Six weeks.

ii. Aquatic Therapy is a well-accepted treatment which consists of the therapeutic use of aquatic immersion for therapeutic exercise to promote ROM, flexibility, strengthening, core stabilization, endurance, body mechanics, and pain management. Aquatic therapy includes the implementation of active therapeutic procedures in a swimming or therapeutic pool. The water provides a buoyancy force that lessens the amount of force gravity applies to the body. The decreased gravity effect allows the patient to have a mechanical advantage and more likely to have a successful trial of therapeutic exercise. Literature has shown that the muscle recruitment for aquatic therapy versus similar non-aquatic motions is significantly less. Because there is always a risk of recurrent or additional damage to the muscle tendon unit after a surgical repair, aquatic therapy may be preferred by surgeons to gain early return of ROM. In some cases the patient will be able to do the exercises unsupervised after the initial supervised session. Parks and recreation contacts may be used to locate less expensive facilities for patients. Indications include:

(a). Postoperative therapy as ordered by the surgeon;

(b). Intolerance for active land-based or full-weight bearing therapeutic procedures;

(c). Symptoms that are exacerbated in a dry environment; and/or

(d). Willingness to follow through with the therapy on a regular basis.

iii. The pool should be large enough to allow full extremity ROM and fully erect posture. Aquatic vests, belts, snorkels, and other devices may be used to provide stability, balance, buoyancy, and resistance.

(a). Time to Produce Effect: Four to five treatments.

(b). Frequency: Three to five times per week.

(c). Optimum Duration: Four to six weeks.

(d). Maximum Duration: Eight weeks.

iv. A self-directed program is recommended after the supervised aquatics program has been established, or, alternatively a transition to a self-directed dry environment exercise program.

v. Functional Activities are well-established interventions which involve the use of therapeutic activity to enhance mobility, body mechanics, employability, coordination, balance, and sensory motor integration.

(a). Time to Produce Effect: Four to five treatments.

(b). Frequency: Three to five times per week.

(c). Optimum Duration: Four to six weeks.

(d). Maximum Duration: Six weeks.

vi. Functional Electrical Stimulation is an accepted treatment in which the application of electrical current to elicit involuntary or assisted contractions of atrophied and/or impaired muscles. Indications include muscle atrophy, weakness, and sluggish muscle contraction secondary to pain, injury, neuromuscular dysfunction or peripheral nerve lesion. Indications also may include an individual who is precluded from active therapy.

(a). Time to Produce Effect: Two to six treatments.

(b). Frequency: Three times per week.

(c). Optimum Duration: Eight weeks.

(d). Maximum Duration: Eight weeks. If functional gains are documented by a therapist, a home unit may be provided.

vii. Neuromuscular Re-education is a generally accepted treatment. It is the skilled application of exercise with manual, mechanical, or electrical facilitation to enhance strength; movement patterns; neuromuscular response; proprioception; kinesthetic sense; coordination; education of movement, balance and posture. Indications include the need to promote neuromuscular responses through carefully timed

proprioceptive stimuli, to elicit and improve motor activity in patterns similar to normal neurologically developed sequences, and to improve neuromotor response with independent control.

(a). Time to Produce Effect: Two to six treatments.

(b). Frequency: Three times per week.

(c). Optimum Duration: Four to eight weeks.

(d). Maximum Duration: Eight weeks.

viii. Therapeutic Exercise is a generally well-accepted treatment. Therapeutic exercise, with or without mechanical assistance or resistance, may include isoinertial, isotonic, isometric and isokinetic types of exercises. The exact type of program and length of therapy should be determined by the treating physician with the physical or occupational therapist. Refer to Specific Diagnosis, Testing and Treatment Procedures regarding specific diagnoses for details. In most cases, the therapist instructs the patient in a supervised clinic and home program to increase motion and subsequently increase strength. Usually, isometrics are performed initially, progressing to isotonic exercises as tolerated.

(a). Time to Produce Effect: Two to six treatments.

(b). Frequency: Two to three times per week.

(c). Optimum Duration: 16 to 24 sessions.

(d). Maximum Duration. 36 sessions. Additional visits may be necessary in cases of re-injury, interrupted continuity of care, exacerbation of symptoms, and in those patients with co-morbidities. Functional gains including increased ROM must be demonstrated to justify continuing treatment.

14. Therapy-Passive. Most of the following passive therapies and modalities are generally accepted methods of care for a variety of work-related injuries. Passive therapy includes those treatment modalities that do not require energy expenditure on the part of the patient. They are principally effective during the early phases of treatment and are directed at controlling symptoms such as pain, inflammation and swelling and to improve the rate of healing soft tissue injuries. They should be used adjunctively with active therapies to help control swelling, pain, and inflammation during the rehabilitation process. They may be used intermittently as a therapist deems appropriate or regularly if there are specific goals with objectively measured functional improvements during treatment.

a. On occasion, specific diagnoses and post-surgical conditions may warrant durations of treatment beyond those listed as "maximum." Factors such as exacerbation of symptoms, re-injury, interrupted continuity of care, and comorbidities may also extend durations of care. Specific goals with objectively measured functional improvement during treatment must be cited to justify extended durations of care. It is recommended that, if no functional gain is

observed after the number of treatments under “time to produce effect” have been completed, alternative treatment interventions, further diagnostic studies, or further consultations should be pursued.

b. The following passive therapies and modalities are listed in alphabetical order.

i. Continuous Passive Movement (CPM): Refer to Rotator Cuff Tear.

ii. Electrical Stimulation (Unattended is an accepted treatment. Unattended electrical stimulation once applied, requires minimal on-site supervision by the physician or non-physician provider. Indications include pain, inflammation, muscle spasm, atrophy, decreased circulation, and the need for osteogenic stimulation.

(a). Time to Produce Effect: Two to four treatments.

(b). Frequency. Varies. Depending upon indication, between two to three times per day to one time a week. Provide home unit if frequent use.

(c). Optimum Duration: One to three months.

(d). Maximum Duration: Three months.

iii. Hyperbaric Oxygen Therapy. There is no evidence to support long-term benefit of hyperbaric oxygen therapy for non-union upper extremity fractures. It is not recommended.

iv. Immobilization: Time is dependent upon type of injury.

(a). Time to Produce Effect: One day.

(b). Frequency: Once.

(c). Optimum Duration: One week.

(d). Maximum Duration: 12 weeks.

(e). The arm may be immobilized in a sling for 1 to 12 weeks post-injury, depending upon the age of the patient and diagnosis. The patient is instructed in isometric exercises while in the sling for the internal and external rotators and the deltoid.

v. Iontophoresis is an accepted treatment which consists of the transfer of medication, including, but not limited to, steroidal anti-inflammatory and anesthetics, through the use of electrical stimulation. Indications include pain (Lidocaine), inflammation (hydrocortisone, salicylate), edema (mecholy, hyaluronidase, salicylate), ischemia (magnesium, mecholy, iodine), muscle spasm (magnesium, calcium), calcifying deposits (acetate), scars, and keloids (chlorine, iodine, acetate).

(a). Time to Produce Effect: One to four treatments.

(b). Frequency: 3 times per week with at least 48 hours between treatments.

(c). Optimum Duration: 8 to 10 treatments.

(d). Maximum Duration: 10 treatments.

vi. Manipulation is a generally accepted, well-established and widely used therapeutic intervention for shoulder injuries. Manipulative treatment (not therapy) is defined as the therapeutic application of manually guided forces by an operator to improve physiologic function and/or support homeostasis that has been altered by the injury or occupational disease, and has associated clinical significance.

(a). High velocity, low amplitude (HVLA) technique, chiropractic manipulation, osteopathic manipulation, muscle energy techniques, counter strain, and non-force techniques are all types of manipulative treatment. This may be applied by osteopathic physicians (D.O.), chiropractors (D.C.), properly trained physical therapists (P.T.), properly trained occupational therapists (O.T.), or properly trained medical physicians. Under these different types of manipulation exist many subsets of different techniques that can be described as direct- a forceful engagement of a restrictive/pathologic barrier, indirect- a gentle/non-forceful disengagement of a restrictive/pathologic barrier, the patient actively assists in the treatment and the patient relaxing, allowing the practitioner to move the body tissues. When the proper diagnosis is made and coupled with the appropriate technique, manipulation has no contraindications and can be applied to all tissues of the body. Pre-treatment assessment should be performed as part of each manipulative treatment visit to ensure that the correct diagnosis and correct treatment is employed.

(i). Time to Produce Effect for all types of manipulative treatment: One to six treatments.

(ii). Frequency: Up to three times per week for the first three weeks as indicated by the severity of involvement and the desired effect.

(iii). Optimum Duration: 10 treatments.

(iv). Maximum Duration. 12 treatments. Additional visits may be necessary in cases of re-injury, interrupted continuity of care, exacerbation of symptoms, and in those patients with co-morbidities. Functional gains including increased ROM must be demonstrated to justify continuing treatment.

vii. Manual Electrical Stimulation is used for peripheral nerve injuries or pain reduction that requires continuous application, supervision, or involves extensive teaching. Indications include muscle spasm (including TENS), atrophy, decreased circulation, osteogenic stimulation, inflammation, and the need to facilitate muscle hypertrophy, muscle strengthening, muscle responsiveness in Spinal Cord Injury/Brain Injury (SCI/BI), and peripheral neuropathies.

(a). Time to Produce Effect: Variable, depending upon use.

(b). Frequency: Three to seven times per week.

(c). Optimum Duration: Eight weeks.



(d). Maximum Duration: Two months.

viii. **Massage—Manual or Mechanical.** Massage is manipulation of soft tissue with broad ranging relaxation and circulatory benefits. This may include stimulation of acupuncture points and acupuncture channels (acupressure), application of suction cups and techniques that include pressing, lifting, rubbing, pinching of soft tissues by, or with, the practitioner's hands. Indications include edema (peripheral or hard and non-pliable edema), muscle spasm, adhesions, the need to improve peripheral circulation and ROM, or to increase muscle relaxation and flexibility prior to exercise. In cases with edema, deep vein thrombosis should be ruled out prior to treatment.

- (a). Time to Produce Effect: Immediate.
- (b). Frequency: One to two times per week.
- (c). Optimum Duration: Six weeks.
- (d). Maximum Duration: Two months.

ix. **Mobilization (Joint)** is a generally well-accepted treatment. Mobilization is passive movement which may include passive ROM performed in such a manner (particularly in relation to the speed of the movement) that it is, at all times, within the ability of the patient to prevent the movement if they so choose. It may include skilled manual joint tissue stretching. Indications include the need to improve joint play, improve intracapsular arthrokinematics, or reduce pain associated with tissue impingement/maltraction.

- (a). Time to Produce Effect: Six to nine treatments.
- (b). Frequency: Three times per week.
- (c). Optimum Duration: Six weeks.
- (d). Maximum Duration: Two months.

x. **Mobilization (Soft Tissue)** is a generally well-accepted treatment. Mobilization of soft tissue is the skilled application of muscle energy, strain/counter strain, myofascial release, manual trigger point release and manual therapy techniques designed to improve or normalize movement patterns through the reduction of soft tissue pain and restrictions. These can be interactive with the patient participating or can be with the patient relaxing and letting the practitioner move the body tissues. Indications include muscle spasm around a joint, trigger points, adhesions, and neural compression. Mobilization should be accompanied by active therapy.

- (a). Time to Produce Effect: Two to three weeks.
- (b). Frequency: Two to three times per week.
- (c). Optimum Duration: Four to six weeks.
- (d). Maximum Duration: Six weeks.

xi. **Superficial Heat and Cold Therapy** is a generally accepted treatment. Superficial heat and cold therapies are thermal agents applied in various manners that lower or raises the body tissue temperature for the reduction

of pain, inflammation, and/or effusion resulting from injury or induced by exercise. It may be used acutely with compression and elevation. Indications include acute pain, edema and hemorrhage, need to increase pain threshold, reduce muscle spasm and promote stretching/flexibility. At the time of the writing of this guideline, continuous cryotherapy units with compression are supported by evidence only in post-surgical patients.

- (a). Time to Produce Effect: Immediate.
- (b). Frequency: Two to five times per week.
- (c). Maximum Duration: One month.

xii. **Transcutaneous Electrical Nerve Stimulation (TENS)** is a generally accepted treatment. TENS should include at least one instructional session for proper application and use. Indications include muscle spasm, atrophy, and decreased circulation and pain control. Minimal TENS unit parameters should include pulse rate, pulse width and amplitude modulation. Consistent, measurable functional improvement must be documented prior to the purchase of a home unit.

- (a). Time to Produce Effect: Immediate.
- (b). Frequency: Variable.
- (c). Optimum Duration: Three sessions.
- (d). Maximum Duration: Three sessions. If beneficial, provide with home unit or purchase if effective.

xiii. **Ultrasound (including Phonophoresis)** is an accepted treatment. Ultrasound includes ultrasound with electrical stimulation and phonophoresis. Ultrasound uses sonic generators to deliver acoustic energy for therapeutic thermal and/or non-thermal soft tissue effects. Indications include scar tissue, adhesions, collagen fiber and muscle spasm, and the need to extend muscle tissue or accelerate the soft tissue healing.

(a). Ultrasound with electrical stimulation is concurrent delivery of electrical energy that involves a dispersive electrode placement. Indications include muscle spasm, scar tissue, and pain modulation and muscle facilitation.

(b). Phonophoresis is the transfer of medication to the target tissue to control inflammation and pain through the use of sonic generators. These topical medications include, but are not limited to, steroidal anti-inflammatory and anesthetics.

- (i). Time to Produce Effect: 6 to 15 treatments.
- (ii). Frequency: Three times per week.
- (iii). Optimum Duration: Four to eight weeks.
- (iv). Maximum Duration: Two months.

15. **Vocational Rehabilitation** is a generally accepted intervention. Initiation of vocational rehabilitation requires adequate evaluation of patients for quantification of highest functional level, motivation and achievement of maximum medical improvement. Vocational rehabilitation may be as

simple as returning to the original job or as complicated as being retrained for a new occupation.

a. It may also be beneficial for full vocational rehabilitation to be started before MMI if it is evident that the injured worker will be unable to return to his/her previous occupation. A positive goal and direction may aid the patient in decreasing stress and depression, and promote optimum rehabilitation.

AUTHORITY NOTE: Promulgated in accordance with R.S. 23:1203.1.

HISTORICAL NOTE: Promulgated by the Louisiana Workforce Commission, Office of Workers Compensation Administration, LR 37:1850 (June 2011), LR 49:524 (March 2023).

### §2327. Therapeutic Procedures—Operative

A. All operative interventions must be based upon positive correlation of clinical findings, clinical course and diagnostic tests. A comprehensive assimilation of these factors must lead to a specific diagnosis with positive identification of pathologic condition(s). It is imperative to rule out non-physiologic modifiers of pain presentation or non-operative conditions mimicking operative conditions (e.g., peripheral neuropathy, myofascial pain, scleratogenous or sympathetically mediated pain syndromes, psychological), prior to consideration of elective surgical intervention.

B. In addition, operative treatment is indicated when the natural history of surgically treated lesions is better than the natural history for non-operatively treated lesions. All patients being considered for surgical intervention should first undergo a comprehensive neuro-musculoskeletal examination to identify mechanical pain generators that may respond to non-surgical techniques or may be refractory to surgical intervention.

C. Structured rehabilitation interventions should be strongly considered post-operative in any patient not making expected functional progress within three weeks post-operative.

D. Post-operative therapy will frequently require a repeat of the therapy provided pre-operatively. Refer to Therapeutic Procedures, Non-operative, and consider the first post-operative visit as visit number one, for the time frame parameters provided.

E. Return-to-work restrictions should be specific according to the recommendation in Therapeutic Procedures—Non-Operative.

#### 1. Shoulder Replacement (Arthroplasty)

a. Description/Definition. Prosthetic replacement of the articulating surfaces of the shoulder joint. There are three types of procedures commonly performed. The total shoulder component in which the glenoid and humeral head are replaced anatomically. The hemiarthroplasty which involves replacement of the humeral head only. The reverse arthroplasty where the head of the humerus is replaced by a prosthesis forming a socket and the glenoid is replaced with a ball prosthesis.

b. Occupational Relationship. Usually from post-traumatic arthritis, or from trauma resulting in severe humeral head fractures.

c. Specific Physical Exam Findings. Stiff, painful shoulder with limited function.

d. Diagnostic Testing Procedures: Radiographs or CTs demonstrating humeral head fracture. CTs or diagnostic arthroscopy to explore the status of rotator cuff and associated muscles and tendons, the presence of arthritis or subluxation, or superior migration of the humeral head. For revision procedures, a non-MRI arthrography or sonogram may be important to better visualize associated pathology.

e. Surgical Indications. The decision of whether a patient receives a total arthroplasty or a hemiarthroplasty depends on the surgeon's discretion. Factors to consider are the presence of glenoid erosions, humeral head subluxation and rotator cuff strength. There is good evidence that total arthroplasties compared to hemi-arthroplasties results in improved function in primary osteoarthritis of the shoulder, and relief of pain two years post-operatively. Longer-term results are unknown.

i. Hemiarthroplasty may utilize a long stem humeral head replacement or a resurfacing device. It may also be performed for humeral head fractures. It has been used for severe arthritis unresponsive to other treatments; however, there is some evidence that total shoulder arthroplasty may yield a better functional outcome. In younger active patients the eventual wear on the glenoid cartilage may cause decreased function over time. Total arthroplasty may therefore be preferred in many cases. Partial humeral head prosthesis may be useful in some cases. Cementless surface humeral head replacement may be indicated in young patients with glenohumeral arthritis and retained glenoid cartilage.

ii. Total shoulder arthroplasty is usually performed in cases of severe arthritis when all reasonable conservative measures have been exhausted without sufficient return to activities of daily living. Arthroscopic surgery may be considered in selected patients with a milder degree of arthritis. Arthroscopic SLAP repair is usually not recommended in cases of severe arthritis. The rotator cuff should generally be intact or repairable.

iii. Reverse arthroplasty is generally considered a salvage procedure for patients over 70 with severe osteoarthritis, massive rotator cuff tears and pseudo paralysis with integrity of the deltoid. Complications rates may be in the vicinity of 10 percent of patients within the first year following surgery. The long-term success of the prosthesis is not known at this time.

iv. Reverse prosthesis may also be the treatment for failed hemiarthroplasty with extensive cuff tears and/or instability. Most literature confirms that the complication rate is higher and the success rate lower when reverse arthroplasty is performed on a previously operated joint, however, many patients demonstrate good improvement

with elevation, but not necessarily rotation. Bone loss may increase the complication rate.

v. Procedural complications may include humeral head subluxation or dislocation, humeral and/or glenoid loosening, rotator cuff tear, fractures, stiffness, painful glenoid erosion, transient nerve palsies, heterotopic ossification, bone loss, and component mal-positioning.

vi. Revision surgery may be performed by an orthopedic surgeon in cases with chronic pain and stiffness, painful glenoid erosion, or difficulty with activities of daily living. Prior authorization is required and a second opinion by a surgeon with special expertise in shoulder surgery should usually be performed. In the case of a total failure of the prosthesis, arthrodesis is the salvage procedure.

f. Operative Treatment: Prosthetic replacement of the articular surfaces of the shoulder.

g. Post-Operative Treatment:

i. Individualized rehabilitation program based on communication between the surgeon and the therapist. Timing of passive motion and active rehabilitation is dependent on the type of procedures performed.

(a). Pool exercise initially under therapists or surgeon's direction then progressed to independent pool program.

(b). Progression to a home exercise is essential. Therapy should continue for at least 10 weeks with transition to home exercises at the beginning of each new phase of therapy.

(c). Gradual resistive exercise from 3 to 12 months, with gradual return to full activity at 6 to 12 months.

(i). Time frames for therapy (excluding pool therapy).

(ii). Optimum: 12 to 24 sessions.

(iii). Maximum: 36 sessions. If functional gains are being achieved additional visits may be authorized for the patient to achieve their functional goal.

ii. Reverse arthroplasty patients may have a more rapid rehabilitation in some cases. Per the recommendation of the surgeon the following therapies may take place: Sling use for the first three weeks, ADLs at three to six weeks, and then gentle strengthening.

iii. Should progress plateau the provider should reevaluate the patient's condition and make appropriate adjustments to the treatment plan. Other therapies may be employed in individual cases.

iv. Gradual return to full activity can occur between 6 to 12 months, depending on the procedure.

v. Return to work and restrictions after surgery may be made by an experienced primary occupational medicine physician in consultation with the surgeon or by the surgeon.

2. Oats Procedure Osteoarticular allograft transplantation is a procedure which places a plug of cadaveric bone tissue into a chondral defect at the articular surface of an injured bone. Its use has been described in case reports in the treatment of recurrent shoulder instability when large humeral head defects (Hill-Sachs lesions) are thought to be responsible for repeated episodes of subluxation. At this time, there is limited information concerning its effectiveness and appropriate application. For this reason, it requires prior authorization as an isolated procedure with a second opinion by a surgeon with special expertise in shoulder surgery. The procedure may be used for isolated chondral/bony deficits involving the humeral head, including avascular necrosis. Partial humeral head prosthesis may be useful in some cases. (Refer to Hemi-arthroplasty)

### 3. Arthrodesis

a. Description/Definition:

i. Fusion of the shoulder. Used as a salvage procedure.

b. Occupational Relationship:

i. Secondary to severe trauma and failure of other procedures.

c. Specific Physical Exam Findings:

i. Shoulder function is minimal and is usually associated with severe rotator cuff pathology.

d. Diagnostic Testing Procedures:

i. See Specific Diagnostic sections.

e. Surgical Indications:

i. Inability to perform activities of daily living, failed previous procedures.

f. Operative Treatment:

i. Fusion.

g. Post-Operative Treatment. An individualized rehabilitation program based upon communication between the surgeon and the therapist. Therapy may begin 6 weeks to 3 months depending on recovery. Occupational therapy is critical to improve function in activities of daily living. Assistive devices may be necessary.

i. Time frames for therapy (excluding pool therapy).

ii. Optimum: 12 to 24 sessions.

iii. Maximum: 36 sessions. If functional gains are being achieved additional visits may be authorized for the patient to achieve their functional goal.

4. Manipulation Under Anesthesia (Refer to Adhesive Capsulitis/Frozen Shoulder Disorder)

### 5. Hardware Removal

a. Description/Definition:

i. Surgical removal of internal or external fixation device, commonly related to fracture repairs.

b. Occupational Relationship:

i. Following healing of a post-traumatic injury that required fixation or reconstruction using instrumentation.

c. Specific Physical Exam Findings:

i. Local pain to palpation, swelling, erythema.

d. Diagnostic Testing Procedures:

i. Radiographs, tomography, CT scan, MRI.

e. Non-operative Treatment:

i. Active and/or passive therapy for local modalities, activity modification. Nonsteroidal Anti-Inflammatory Drugs (NSAIDs).

f. Surgical Indications:

i. Persistent local pain, irritation around hardware.

g. Operative Treatment:

i. Removal of instrumentation may be accompanied by scar release/resection, capsular release, and/or manipulation. Some instrumentation may be removed in the course of standard treatment without local irritation.

h. Post-Operative Treatment:

i. Include an individualized rehabilitation program based upon communication between the surgeon and the therapist.

ii. Early rehabilitation interventions are recommended to maintain range-of-motion and progressive strengthening.

(a). Frequency – Three to five times per week for the first two weeks, three times per week for the following two weeks, then one to two times per week.

(b). Optimum Duration for six to eight weeks with progression to home exercise and or pool therapy.

(c). Maximum Duration – 12 weeks. Occasional follow-up visits may be justified to reinforce exercise patterns, or to reach final functional goals if the therapy to date has demonstrated objective functional gains.

(d). Return to work and restrictions after surgery may be made by an experienced primary occupational medicine physician in consultation with the surgeon or by the surgeon.

5. Human Bone Morphogenetic Protein (RhBMP) is a member of a family of proteins which are involved in the growth, remodeling, and regeneration of bone tissue. It has become available as a recombinant biomaterial with osteo-inductive potential for application in long bone fracture non-union and other situations in which the promotion of bone formation is desired. In the treatment of non-union of

fractures of the humerus and clavicle, no controlled clinical trials have been conducted as of this date, though small case series have resulted in union of some fractures. Ectopic ossification into adjacent muscle has been reported to restrict motion in periarticular fractures. Due to lack of information on the incidence of complications and overall success rate, its use requires prior authorization. It should be used principally for non-union of fractures that have not healed with conventional surgical management or peri-prosthetic fractures.

AUTHORITY NOTE: Promulgated in accordance with R.S. 23:1203.1.

HISTORICAL NOTE: Promulgated by the Louisiana Workforce Commission, Office of Workers Compensation Administration, LR 37:1860 (June 2011).

**§2328. LWC-WC 1009. Disputed Claim for Medical Treatment**

E-Mail to: mgd1009@lwc.la.gov

Fax to: OWCA—Medical Services I. Last four digits of Social Security No. \_\_\_\_\_

ATTN: Medical Director 2. Date of Injury/Illness \_\_\_-\_\_-\_\_

(225) 342-9836 3. Parts of Body Injury \_\_\_\_\_

Mail to: Medical Services 4. Date of Birth \_\_\_-\_\_-\_\_

P.O. Box 94040 5. Date of This Request \_\_\_-\_\_-\_\_

Baton Rouge, LA 70804 6. Claim Number \_\_\_\_\_

**DISPUTED CLAIM FOR MEDICAL TREATMENT (1009)**

NOTE: THIS REQUEST WILL NOT BE HONORED UNLESS THERE ARE MEDICAL SERVICES IN DISPUTE AS PER R.S. 23:1203.1 J AND THE FOLLOWING HAS OCCURRED:

- A. The insurer has issued a denial;
- B. The insurer has issued an approval with modification;
- C. The insurer's failure to act has resulted in a deemed/tacit denial; or
- D. The aggrieved party is seeking a variance from the medical treatment schedule

DISPUTES RELATING TO COMPENSABILITY AND/OR CAUSATION ARE NOT ADDRESSED BY THE MEDICAL DIRECTOR.

GENERAL INFORMATION

An aggrieved party files this dispute with the Office of Workers' Compensation – Medical Services Director by mail, email or fax. This office must be notified immediately in writing of changes in address. An employee may be represented by an attorney, but it is not required. The completed LWC-WC-1009 must be submitted to OWCA within 15 calendar days of the 1010 denial, 1010 approval w/modification or 1010 deemed/tacit denial. A deemed/tacit denial is when a carrier/self-insured employer fails to return the LWC-WC-1010 form within five business days of submission of the form to the carrier/self-insured employer.

7. This request is submitted by  
 \_\_\_ Employee \_\_\_ Health Care Provider \_\_\_ Other \_\_\_\_\_

The following records/documents MUST be attached to this request. Failure to do so may result in the rejection of the request by the OWCA director:

A. Copies of all relevant information must be included with this request as per LAC 40:I.2715(J) including a copy of the LWC-WC-1010 and all of the information previously submitted to the carrier/self-insured employer.

- B. If applicable, a copy of the denial letter issued by the insurance carrier or utilization review company.
- C. Include scientific medical evidence when seeking a variance.

**EMPLOYEE**

8. Name \_\_\_\_\_  
 Street or Box \_\_\_\_\_  
 City \_\_\_\_\_  
 State \_\_\_\_\_ Zip \_\_\_\_\_  
 Phone (\_\_\_\_) \_\_\_\_\_

**EMPLOYEE'S ATTORNEY (if any)**

9. Name \_\_\_\_\_  
 Street or Box \_\_\_\_\_  
 City \_\_\_\_\_  
 State \_\_\_\_\_ Zip \_\_\_\_\_  
 Phone (\_\_\_\_) \_\_\_\_\_  
 Fax (\_\_\_\_) \_\_\_\_\_  
 Email \_\_\_\_\_

**EMPLOYER**

(circle one)

10. Name \_\_\_\_\_  
 Street or Box \_\_\_\_\_  
 City \_\_\_\_\_  
 State \_\_\_\_\_ Zip \_\_\_\_\_  
 Phone (\_\_\_\_) \_\_\_\_\_  
 Fax (\_\_\_\_) \_\_\_\_\_

**INSURER/ADMINISTRATOR**

11. Name \_\_\_\_\_  
 Street or Box \_\_\_\_\_  
 City \_\_\_\_\_  
 State \_\_\_\_\_ Zip \_\_\_\_\_  
 Phone (\_\_\_\_) \_\_\_\_\_  
 Fax (\_\_\_\_) \_\_\_\_\_  
 Email \_\_\_\_\_

**TREATING/REQUESTING PHYSICIAN**

12. Name \_\_\_\_\_  
 Street or Box \_\_\_\_\_  
 City \_\_\_\_\_  
 State \_\_\_\_\_ Zip \_\_\_\_\_  
 Phone (\_\_\_\_) \_\_\_\_\_  
 Fax (\_\_\_\_) \_\_\_\_\_  
 Email \_\_\_\_\_

13. PLEASE PROVIDE A SUMMARY OF THE DETAILS REGARDING THE ISSUE AT DISPUTE:  
 (If requesting a variance, explain here)

\_\_\_\_\_  
 \_\_\_\_\_  
 \_\_\_\_\_  
 \_\_\_\_\_  
 \_\_\_\_\_  
 \_\_\_\_\_  
 \_\_\_\_\_  
 \_\_\_\_\_  
 \_\_\_\_\_  
 \_\_\_\_\_  
 \_\_\_\_\_

You may attach a letter or petition with additional information with this disputed claim.

By signing below, you are certifying that this form along with all supporting documentation has been sent to the carrier/self-insured employer this date by email or fax.

The information given above is true and correct to the best of my knowledge and belief.

\_\_\_\_\_  
 SIGNATURE OF REQUESTING PARTY (Required)      DATE

\_\_\_\_\_  
 Printed Name of Requesting Party

LWC-WC 1009-Rev 08/2024

**AUTHORITY NOTE:** Promulgated in accordance with R.S. 23:1203.1.

**HISTORICAL NOTE:** Promulgated by the Louisiana Workforce Commission, Office of Workers Compensation Administration, LR 38:3254 (December 2012), amended LR 51:85 (January 2025).

## Chapter 25. Hospital Reimbursement Schedule, Billing Instruction and Maintenance Procedures

Editor's Note: Other Sections applying to this Chapter can be found in Chapter 51.

**§§2501-2503. Reserved.**

### §2505. Hospital Inpatient Reimbursement

A. Reimbursement for inpatient hospital services will be limited to the lesser of covered billed charges or the per diem amount. The per diem rate assigned to the Standard Metropolitan Statistical Area in which the services are rendered will be applied to inpatient days by type of service, either medical or surgical.\* The reimbursement amount will be reduced by charges for noncovered items and services.

NOTE: \*The diagnosis/procedure code requiring the greatest resource consumption (severity) should be used to assign the correct category.

B. Using the following Per Diem Rate Schedule, the formula for calculating payment amount is:

$$\text{Per Diem Rate} \times \text{Inpatient Days} = \text{per Diem Amount}$$

1. If billed charges > per diem amount, pay per diem amount less noncovered charges.

2. If billed charges < per diem amount, pay billed charges less noncovered charges.

Per Diem Rate Schedule		
SMSA*	Medical per Diem	Surgical per Diem
Alexandria	\$1212	\$1628
Baton Rouge	\$1125	\$2015
Houma-Thibodaux	\$ 908	\$1697
Lafayette	\$1009	\$1655
Lake Charles	\$ 946	\$1645
Monroe	\$1050	\$1654

LABOR AND EMPLOYMENT

New Orleans	\$1186	\$2059
Nonmetropolitan	\$ 771	\$1570
Shreveport	\$1198	\$1629
*Please refer to Exhibit I for listing of hospitals within each SMSA.		

C. A provider formally approved by Medicare as a rural referral center will be recognized as such under these rules, and will be reimbursed under the same per diem rate as that of the SMSA assigned to the provider by the Medicare Geographic Classification Review Board.

D. Exhibit 1

Hospitals by Area			
Alexandria	Monroe	New Orleans	Nonmetropolitan
Bayou Rapides Byrd Memorial Rapides General St. Frances Cabrini	Glenwood Regional Medical Center HCA North Monroe Hospital Lincoln General St. Francis Medical Center St. Erlington Hospital	Childrens Hospital De La Ronde Hospital Doctors Hospital of Jefferson East Jefferson General Elmwood Medical Center Eye, Ear, Nose and Throat Highland Park Hospital Hotel Dieu Hospital Humana Hospital—New Orleans Jo Ellen Smith/F. Edward Hebert Lakeside Hospital Meadowcrest Hospital Mercy Hospital of New Orleans New Orleans General Northshore Regional Medical Ochsner Foundation Pendleton Memorial Methodist River Parishes Hospital Slidell Memorial Southern Baptist Hospital St. Charles Hospital St. Charles Hospital/Luling St. Jude Medical Center St. Tammany Parish Touro Infirmary Tulane Medical Center United Medical Center West Jefferson Medical Center	Abbeville General Abrom Kaplan Memorial Acadia Saint Landry Allen Parish American Legion Hospital Assumption General Bienville General Bogalusa Community Bunkie General Caldwell Memorial Citizens Medical Center Dauterive Hospital Desoto General East Carroll Parish Franklin Foundation Franklin Parish Hardtner Medical Center Homer Memorial Hood Memorial Humana Hospital—Marksville Humana Hospital—Oakdale Humana Hospital—Ville Platte Humana Hospital—Winn Parish Iberia General Jackson Parish Jennings American Legion L.S. Huckabay Medical Memorial Lakewood Hospital Lasalle General Madison Parish Merryville General Moosa Memorial Hospital Morehouse General Natchitoches Parish Pointe Coupee General Richland Parish—Delhi Richland Parish—Rayville Riverland Medical Center Riverside Medical Center Sabine Medical Center Savoy Memorial Hospital South Cameron Memorial St. Helena Parish St. James Parish Tri Ward General Union General West Carroll Memorial West Feliciana Parish
<b>Baton Rouge</b> Ascension Hospital Baton Rouge General Medical Lane Memorial Medical Center of Baton Rouge Our Lady of the Lake Prevost Memorial Hospital Riverview Medical Center River West Medical Center Seventh Ward Community Westpark Community Hospital Womans Hospital	<b>Lake Charles</b> Beauregard Memorial Dequincy Memorial Humana Hospital—Lake Charles Lake Charles Memorial St. Patrick Hospital West Calcasieu—Cameron		
	<b>Shreveport</b> Bossier Medical Center Doctors Hospital Highland Hospital Humana Hospital—Springhill LSU Medical Center Minden Medical Hospital North Caddo Memorial Physicians and Surgeons Riverside Community Schumpert Hospital Willis Knighton Medical		
<b>Houma-Thibodaux</b> Lady of the Sea General St. Anne General Terrebonne General Thibodaux Hospital			
<b>Lafayette</b> Doctors Hospital of Opelousas Gary Memorial Hospital Hamilton Medical Center Lafayette General Hospital Opelousas General Hospital Our Lady of Lourdes Womens and Childrens Hospital			

AUTHORITY NOTE: Promulgated in accordance with R.S. 23:1034.2.

HISTORICAL NOTE: Promulgated by the Department of Labor, Office of Workers' Compensation, LR 19:54 (January 1993), repromulgated LR 19:212 (February 1993), amended LR 20:1299 (November 1994).

**§2507. Outpatient Reimbursement**

A. Outpatient hospital and ambulatory surgery services will be reimbursed at covered charges less a 10 percent discount. The formula for calculating payment amount is:

$$\text{(Billed Charges) - (Noncovered Charges) = Covered Charges} \times 0.90 = \text{Payment Amount}$$

B. If a patient is admitted as an outpatient, however; is in the hospital overnight, this will be considered outpatient

services. When patient is in hospital by midnight census of day two, this becomes an inpatient admission, thus services are paid at per diem rate. In addition, all procedures which can safely be performed as outpatient procedures shall be reimbursed as such. (Reference the Utilization Review Procedures, Chapter 27).

C. For a hospital admission to be subject to inpatient reimbursement, it must be medically necessary and not solely for the convenience of the payor.

AUTHORITY NOTE: Promulgated in accordance with R.S. 23:1034.2.

HISTORICAL NOTE: Promulgated by the Department of Labor, Office of Workers' Compensation, LR 19:54 (January 1993), repromulgated LR 19:212 (February 1993), amended LR 20:1299 (November 1994).

**§2509. Psychiatric and Chemical Dependency Reimbursement**

A. Inpatient. Reimbursement for inpatient psychiatric and/or chemical dependency unit services will be limited to the lesser of covered billed charges or the per diem amount.

1. The uniform statewide per diem rates will be applied to inpatient days by type of service, either psychiatric or chemical dependency.

2. The reimbursement amount will be reduced by charges for noncovered items and services.

Per Diem Rate Schedule	
Psychiatric Services	\$799
Chemical Dependency Unit Services	\$597

3. Using the above per diems, the formula for calculating payment amount is the same as that for acute care inpatient services found in §2505.B.1.

B. Outpatient. Psychiatric and chemical dependency services rendered on an outpatient basis by professional providers such as medical doctors, Ph.D. psychologists, and social workers will be reimbursed based on the medical reimbursement schedule for related CPT-4 Procedure Codes promulgated by the state of Louisiana, Office of Workers' Compensation. Any facility fees associated with providing these professional services will be reimbursed at covered charges less a 10 percent discount. The formula for calculating payment amount is:

$$(Billed\ Charges) - (Noncovered\ Charges) = Covered\ Charges \times 0.90 = Payment\ Amount$$

AUTHORITY NOTE: Promulgated in accordance with R.S. 23:1034.2.

HISTORICAL NOTE: Promulgated by the Department of Labor, Office of Workers' Compensation, LR 19:54 (January 1993), repromulgated LR 19:212 (February 1993), amended LR 20:1299 (November 1994).

**§2511. Rehabilitation Services Reimbursement**

A. Inpatient. Reimbursement for inpatient rehabilitation facility services will be limited to the lesser of covered billed charges or the per diem amount.

1. The uniform statewide per diem rate will be applied to inpatient days by type of facility, either hospital based or freestanding.

2. The reimbursement amount will be reduced by charges for noncovered items and services.

Per Diem Rate Schedule	
Hospital Based Rehabilitation Facility	\$ 704
Freestanding Rehabilitation Facility	\$1225

3. Using the above per diems, the formula for calculating payment amount is the same as that for inpatient hospital services found in §2505.B.1.

B. Outpatient. Rehabilitation services rendered on an outpatient basis by professional providers such as medical doctors, physical therapists, occupational therapists, and

speech therapists will be reimbursed based on the customary and reasonable fee schedule for related CPT-4 procedure codes promulgated by the state of Louisiana, Office of Workers' Compensation. Any facility fees associated with delivery of these professional services will be reimbursed at covered charges less a 10 percent discount. The formula for calculating payment is:

$$(Billed\ Charges) - (Noncovered\ Charges) = Covered\ Charges \times 0.90 = Payment\ Amount$$

AUTHORITY NOTE: Promulgated in accordance with R.S. 23:1034.2.

HISTORICAL NOTE: Promulgated by the Department of Labor, Office of Workers' Compensation, LR 19:54 (January 1993), repromulgated LR 19:212 (February 1993), amended LR 20:1299 (November 1994).

**§2513. Skilled Nursing and Intermediate Facility Reimbursement**

A. Reimbursement for skilled nursing facility or intermediate care (swing bed) facility services will be limited to the lesser of covered billed charges or the per diem amount.

1. The uniform statewide per diem rates will be applied to inpatient days by type of facility, either hospital-based or freestanding.

2. The reimbursement amount will be reduced by charges for noncovered items and services.

Per Diem Rate Schedules	
<b>Skilled Nursing Facility</b>	
Hospital Based	\$294
Freestanding	\$ 69
<b>Intermediate Care Facility</b>	
Hospital Based	\$224
Freestanding	\$ 63

3. Using the above per diems, the formula for calculating payment amount is the same as that for inpatient hospital services found in §2505.B.1.

AUTHORITY NOTE: Promulgated in accordance with R.S. 23:1034.2.

HISTORICAL NOTE: Promulgated by the Department of Labor, Office of Workers' Compensation, LR 19:54 (January 1993), repromulgated LR 19:212 (February 1993), amended LR 20:1299 (November 1994).

**§2515. Hospice Services Reimbursement**

A. Hospice care services will be reimbursed at the lesser of covered billed charges or the per diem, per shift, or per hour rate.

1. The uniform statewide rates depicted in the table below will be applied by type of facility, either hospital based or freestanding.

2. The four categories of service are defined by the intensity of care, the skill level of the caregiver, and the place of service as follows.

a. Routine Home Care. The hospice is paid the routine home care rate for each day the patient is under the



care of the hospice and not receiving one of the other categories of hospice care. This rate is paid without regard to the volume or intensity of routine home care services provided on any given day, and is also paid when the patient is receiving hospital care for a condition unrelated to their terminal condition.

b. **Continuous Home Care.** Continuous home care is to be provided only during a period of crisis. A period of crisis is a period in which a patient requires continuous care which is primarily nursing care to achieve management of acute medical symptoms.

i. Nursing care must be provided by either a registered nurse or a licensed practical nurse and a nurse must be providing care for more than half of the period of care.

ii. A minimum of eight hours of care must be provided during a 24 hour day which begins and ends at midnight. This care need not be continuous.

iii. Continuous home care is covered when it is provided to maintain an individual at home during a medical crisis. If less skilled care is needed on a continuous basis to enable the person to remain at home, this is covered as routine home care.

c. **Respite Care.** Respite care is short-term inpatient care provided to the individual only when necessary to relieve the family members or other persons caring for the individual at home. Respite care may be provided only on an occasional basis and may not be reimbursed for more than five consecutive days at a time. Payment for the sixth and any subsequent days is to be made at the routine home care rate.

d. **General Inpatient Care.** Payment at the inpatient rate is made when general inpatient care is provided. None of the other fixed payment rates are applicable for a day on which the patient receives hospice inpatient care.

**AUTHORITY NOTE:** Promulgated in accordance with R.S. 23:1034.2.

**HISTORICAL NOTE:** Promulgated by the Department of Labor, Office of Workers' Compensation, LR 19:54 (January 1993), repromulgated LR 19:212 (February 1993), amended LR 20:1299 (November 1994).

**§2517. Hospice Care Rate Schedule**

A. Schedule

	<b>Routine</b>	<b>*Continuous</b>	<b>Respite</b>	<b>General Inpatient</b>
Hospital Based	\$114	\$28	\$117	\$504
Freestanding	\$116	\$29	\$120	\$513

\*(Continuous Home Care is an hourly rate. All others are per diems)

B. The formulas for calculating payment amount by category of service are:

1. routine home care, respite care and general inpatient care:

Per Diem Rate x days = Per Diem Amount;

- a. if billed charges > per diem amount, pay per diem amount less noncovered charges;
- b. if billed charges < per diem amount, pay billed charges less noncovered charge;

2. continuous home care—the rate quoted is an hourly rate. As defined above, to be covered, continuous home care must be provided for a minimum of eight hours.

Hourly Rate x Hours of Care Provided = Payment Amount

**AUTHORITY NOTE:** Promulgated in accordance with R.S. 23:1034.2.

**HISTORICAL NOTE:** Promulgated by the Department of Labor, Office of Workers' Compensation, LR 19:54 (January 1993), repromulgated LR 19:212 (February 1993), amended LR 20:1299 (November 1994).

**§2519. Outlier Reimbursement and Appeals Procedures**

A. **Automatic Outliers.** Inpatient hospital acute care services falling within certain diagnosis code ranges will be reimbursed outside the normal per diem reimbursement method. These atypical admissions will be paid at covered billed charges less a 15 percent discount. Conditions requiring acute care inpatient hospital services that are work-related and are recognized as "automatic outliers" are:

- 1. AIDS: ICD-10 diagnosis code B20;
- 2. Acute Myocardial Infarction: ICD10 diagnosis codes: I213, I214, I220, I221, I222, I228, I229; I2101, I2102, I2109, I2111, I2119, I2121, I2129; and
- 3. severe burns: ICD-10 diagnosis codes: T2030XA, T20311A, T20312A, T20319A, T2032XA, T2033XA, T2034XA, T2035XA, T2036XA, T2037XA, T2039XA, T2070XA, T20711A, T20712A, T20719A, T2072XA, T2073XA, T2074XA, T2075XA, T2076XA, T2077XA, T2079XA; T2130XA, T2131XA, T2132XA, T2133XA, T2134XA, T2135XA, T2136XA, T2137XA, T2139XA, T2170XA, T2171XA, T2172XA, T2173XA, T2174XA, T2175XA, T2176XA, T2177XA, T2179XA; T2230XA, T22311A, T22312A, T22319A, T22321A, T22322A, T22329A, T22331A, T22332A, T22339A, T22341A, T22342A, T22349A, T22351A, T22352A, T22359A, T22361A, T22362A, T22369A, T22391A, T22392A, T22399A, T2270XA, T22711A, T22712A, T22719A, T22721A, T22722A, T22729A, T22731A, T22732A, T22739A, T22741A, T22742A, T22749A, T22751A, T22752A, T22759A, T22761A, T22762A, T22769A, T22791A, T22792A, T22799A; T23301A, T23302A, T23309A, T23311A, T23312A, T23319A, T23321A, T23322A, T23329A, T23331A, T23332A, T23339A, T23341A, T23342A, T23349A, T23351A, T23352A, T23359A, T23361A, T23362A, T23369A, T23371A, T23372A, T23379A, T23391A, T23392A, T23399A, T23701A, T23702A, T23709A, T23711A, T23712A, T23719A, T23721A, T23722A, T23729A, T23731A, T23732A, T23739A, T23741A, T23742A, T23749A, T23751A, T23752A, T23759A, T23761A, T23762A, T23769A, T23771A, T23772A, T23779A, T23791A, T23792A, T23799A; T24301A, T24302A, T24309A, T24311A, T24312A, T24319A, T24321A, T24322A,

LABOR AND EMPLOYMENT

T24329A, T24331A, T24332A, T24339A, T24391A,  
 T24392A, T24399A, T24701A, T24702A, T24709A,  
 T24711A, T24712A, T24719A, T24721A, T24722A,  
 T24729A, T24731A, T24732A, T24739A, T24791A,  
 T24792A, T24799A; T25311A, T25312A, T25319A,  
 T25321A, T25322A, T25329A, T25331A, T25332A,  
 T25339A, T25391A, T25392A, T25399A, T25711A,  
 T25712A, T25719A, T25721A, T25722A, T25729A,  
 T25731A, T25732A, T25739A, T25791A, T25792A,  
 T25799A; T2600XA, T2601XA, T2602XA, T2610XA,  
 T2611XA, T2612XA, T2620XA, T2621XA, T2622XA,  
 T2630XA, T2631XA, T2632XA, T2640XA, T2641XA,  
 T2642XA, T2650XA, T2651XA, T2652XA, T2660XA,  
 T2661XA, T2662XA, T2670XA, T2671XA, T2672XA,  
 T2680XA, T2681XA, T2682XA, T2690XA, T2691XA,  
 T2692XA; T270XXA, T271XXA, T272XXA, T273XXA,  
 T274XXA, T275XXA, T276XXA, T277XXA; T281XXA,  
 T282XXA, T283XXA, T2840XA, T28411A, T28412A,  
 T28419A, T2849XA, T285XXA, T286XXA, T287XXA,  
 T288XXA, T28911A, T28912A, T28919A, T2899XA;  
 T300; T304; T310, T320; T3110, T3210; T3111, T3211;  
 T3120, T3220; T3121, T3221; T3122, T3222; T3130,  
 T3230; T3131, T3231; T3132, T3232; T3133, T3233;  
 T3140, T3240; T3141, T3142, T3143, T3243; T3144,  
 T3244; T3150, T3250; T3152, T3252; T3151, T3251;  
 T3154, T3254; T3153, T3253; T3155, T3255; T3160,  
 T3260; T3161, T3261; T3162, T3262; T3163, T3263;  
 T3164, T3264; T3165, T3265; T3166, T3266; T3170,  
 T3270; T3171, T3271; T3172, T3272; T3173, T3273;  
 T3174, T3274; T3175, T3275; T3176, T3276; T3177,  
 T3277; T3180, T3280; T3181, T3281; T3182, T3282;  
 T3183, T3283; T3184, T3284; T3185, T3285; T3186,  
 T3286; T3187, T3287; T3188, T3288; T3190, T3290;  
 T3191, T3291; T3192, T3292; T3191, T3293; T3194,  
 T3294; T3196, T3296; T3195, T3295; T3197, T3297;  
 T3198, T3298; T3199, T3299.

B. Appeal Procedures. Special reimbursement consideration will be given to cases that are atypical in nature due to case acuity causing unusually high charges when compared to the provider's usual case mix. This appeal process applies to workers' compensation cases paid under the per diem reimbursement formula limiting the payment amount to the lesser of per diem or covered billed charges.

1. The following general criteria will be applied to determine when a case, originally paid at the per diem rate, may be appealed:

- a. total charges for an inpatient hospital surgical admit are greater than or equal to \$100,000;
- b. total charges for an inpatient hospital medical admit are greater than or equal to \$75,000;
- c. average per day charge for any case (inpatient hospital, rehabilitation, SNF, etc.) equates to 1.75 times the applicable per diem rate.

2. When a provider determines that a case falls within the appealable criteria, a request for review may be submitted to the carrier/self-insured employer.

3. If denied, a provider may then file a formal appeal with the Office of Workers' Compensation using the Special Reimbursement Consideration Appeal Form (LDOL-WC-3000) (see §2519.B.7.a.Exhibit II). Forms are available upon request from the Office of Workers' Compensation at the address shown on the sample form. Procedures for filing an appeal and documentation required are provided on the form.

4. Final determination as to acceptance of a case for special reimbursement rests solely with the state of Louisiana, Office of Workers' Compensation.

5. If approved, the provider will be reimbursed at covered billed charges less a 15 percent discount.

6. The formula for calculation of the reimbursement amount for both automatic outliers and approved appeal cases is:

$$\text{(Billed Charges) - (Noncovered Charges) = Covered Charges} \times 0.85 = \text{Payment Amount}$$

7. All workers' compensation claims paid outside the per diem reimbursement method either as automatic outliers or as Special Reimbursement Consideration Appeal cases are subject to on-site bill audit. Bill audits are governed by the rules and procedures found in the Utilization Review Procedures Manual. Please refer to that manual for details.

a. Exhibit II



Louisiana Department of Employment & Training  
 Office of Workers' Compensation  
 P. O. Box 94040  
 Baton Rouge, LA 70804-9040

**EXHIBIT II**

**SPECIAL  
 REIMBURSEMENT  
 CONSIDERATION  
 APPEAL**

**INSTRUCTIONS:** Please provide the following information and return Parts 1 and 2 intact with the required medical records to the address shown below. Send Part 3 to the Workers' Compensation insurance carrier. Retain the last copy for your files. It should be understood that an appeal is not a guarantee of additional reimbursement.

DATE	WORKERS' COMPENSATION CARRIER NAME AND ADDRESS
------	--

**HOSPITAL INFORMATION**

HOSPITAL NAME			
ADDRESS		CITY	
CONTACT PERSON	TITLE	TELEPHONE NO.	EXT.

**PATIENT INFORMATION**

PATIENT NAME		SOCIAL SECURITY NUMBER	
EMPLOYER NAME AND ADDRESS		DATES OF SERVICE	
PATIENT ADDRESS	CITY	STATE	ZIP CODE
DIAGNOSIS AND SURGICAL PROCEDURES			
WAS ADMISSION PRE-CERTIFIED? <input type="checkbox"/> YES <input type="checkbox"/> NO	IF NO, HAS OFFICE OF WORKERS' COMPENSATION BEEN NOTIFIED OF THE ADMISSION?		<input type="checkbox"/> YES <input type="checkbox"/> NO

**MEDICAL INFORMATION**

The following information **must** be submitted with an appeal for special reimbursement consideration.

- Entire medical record
- All supporting information which could substantiate percentage of charge reimbursement
- Itemization of charges

STATE OFFICE OF WORKERS' COMPENSATION USE ONLY		
SPECIAL CASE CONSIDERATION	<input type="checkbox"/> APPROVED	<input type="checkbox"/> DENIED
NAME	TITLE	REIMBURSEMENT RATE
REASON		

**SEND THIS  
 FORM TO:**

Louisiana Department of Employment & Training  
 Office of Workers' Compensation  
 P. O. Box 94040  
 Baton Rouge, La 70804-9040

**AUTHORITY NOTE:** Promulgated in accordance with R.S. 23:1034.2.

**HISTORICAL NOTE:** Promulgated by the Department of Labor, Office of Workers' Compensation, LR 19:54 (January 1993), repromulgated LR 19:212 (February 1993), amended LR 20:1299 (November 1994), amended by the Workforce Commission, Office of Workers' Compensation Administration, LR 41:981 (May 2015), repromulgated LR 41:1774 (September 2015), amended LR 42:283 (February 2016).

### **§2521. Hospital Billing Instructions**

#### **A. Introduction**

1. The purpose of this document is to facilitate the billing process for hospital services.

2. For an overview of the workers' compensation program and policies covering treatment of compensable work-related injuries and illnesses, please refer to the carrier/self-insured employer.

**B. Verification of Coverage.** The carrier/self-insured employer is responsible for 100 percent of the maximum allowable reimbursement rate for covered services rendered for treatment of compensable conditions. The claimant is not required to contribute a copayment and does not have to meet any deductibles.

1. Prior to the provision of medical services, supplies, or other nonmedical services the determination that the illness, injury, or condition is work-related must be made, and must be accomplished in the following manner:

a. carrier/self-insured employer should be contacted for verification of coverage/liability;

b. the name and title of the individual verifying coverage/liability must be recorded in the claimant's records;

c. denial of coverage/liability must be immediately communicated to the claimant.

2. Those procedures identified in this reimbursement schedule as noncovered are not billable to the claimant if rendered in treatment of compensable conditions unless the claimant is informed beforehand that he will be responsible for the charges.

3. In certain circumstances, the provider collects his fees from the claimant because he is unsure or unaware of the occupational nature of the injury or condition. If the

provider decides to bill the workers' compensation carrier/self-insured employer after compensability has been established, he must, to the best of his knowledge, make certain that the claimant has not already filed for reimbursement. If the claimant has not filed, the provider should bill the carrier/self-insured employer and reimburse the claimant. To avoid duplicate billings, the provider should file for the claimant, billing the full amount; or, the claimant should bill the full amount himself.

4. For covered services, if there is a difference between the provider's billed amount and the Office of Workers' Compensation maximum allowable reimbursement, the claimant, employer, and carrier cannot, under any circumstances, be billed for the difference.

#### **C. Pre-Certification**

1. Pre-certification is required for all admissions.

2. Please refer to the Managed Care Program Section of the Utilization Review Manual for definitions and requirements.

**AUTHORITY NOTE:** Promulgated in accordance with R.S. 23:1034.2.

**HISTORICAL NOTE:** Promulgated by the Department of Labor, Office of Workers' Compensation, LR 19:54 (January 1993), repromulgated LR 19:212 (February 1993), amended LR 20:1299 (November 1994).

### **§2523. Required Information for Billing Inpatient Services**

#### **A. Itemization**

1. Billing for hospital and other institutional type services must be submitted on a UB-92 Form as developed and implemented by the National Uniform Billing (UB-92) Committee. A copy of this form is on the last page of this Section.

2. Please itemize inpatient charges with the applicable UB-92 revenue codes. The use of all inclusive accommodation and ancillary revenue codes is not acceptable. These codes may contain services which are noncovered.

3. Invalid revenue codes which are not assigned or defined in the UB-92 manual are not allowed.

Title 40, Part I

4. Sample UB-92 Form

		APPROVED OMB NO. 0938-0279	
2		3 PATIENT CONTROL NO.	
5 FED. TAX NO.		6 STATEMENT COVERS PERIOD FROM THROUGH	
7 COV. D.		8 N-C D.	
9 C-I D.		10 L-R D.	
11			
12 PATIENT NAME		13 PATIENT ADDRESS	
14 BIRTHDATE		15 SEX	
16 MS		17 DATE	
18 HR		19 TYPE & 20 SER.	
21 D HR		22 STAT	
23 MEDICAL RECORD NO.		24	
25		26	
27		28	
29		30	
31		32	
33		34	
35		36	
37		38	
39		40	
41		42	
43		44	
45		46	
47		48	
49		50	
51		52	
53		54	
55		56	
57		58	
59		60	
61		62	
63		64	
65		66	
67		68	
69		70	
71		72	
73		74	
75		76	
77		78	
79		80	
81		82	
83		84	
85		86	
87		88	
89		90	
91		92	
93		94	
95		96	
97		98	
99		100	

**DUE FROM PATIENT**

**X**

UB-92 HCFA-1450 OCR / Original I CERTIFY THE CERTIFICATIONS ON THE REVERSE APPLY TO THIS BILL AND ARE MADE A PART HEREOF.

LABOR AND EMPLOYMENT

AUTHORITY NOTE: Promulgated in accordance with R.S. 23:121034.2.

HISTORICAL NOTE: Promulgated by the Department of Labor, Office of Workers' Compensation, LR 19:54 (January 1993), repromulgated LR 19:212 (February 1993), amended LR 20:1299 (November 1994).

**§2525. Inpatient Services Not Billable on the UB-92**

A. The following inpatient services are not billable on the UB-92 Form unless they are customarily billed in that manner:

1. durable medical equipment when charges exceed \$150;
2. orthotic/prosthetic appliance when charges exceed \$150 (Pacemakers and other surgically implanted devices may be billed on UB-92);
3. ambulance;
4. psychiatric/psychological treatments and services;
5. therapeutic services;
6. professional services customarily billed separately must be billed on the HCFA-1500 Claim Form; and
7. separate sets of billing instructions have been developed for the following services:
  - a. professional services (including chiropractor and physical therapy);
  - b. durable medical equipment and supplies;
  - c. prosthetic and orthotic equipment;
  - d. medical transportation (ambulance);
  - e. respiratory therapy; and
  - f. nursing/home health and attendant services.

AUTHORITY NOTE: Promulgated in accordance with R.S. 23:1034.2.

HISTORICAL NOTE: Promulgated by the Department of Labor, Office of Workers' Compensation, LR 19:54 (January 1993), repromulgated LR 19:212 (February 1993), amended LR 20:1299 (November 1994).

**§2527. Inpatient Revenue Codes Not Billable on the UB-92**

A. The following revenue codes must be billed on the HCFA 1500 Form as professional services.

Revenue Code(s)	Description
290	Durable Medical Equipment (DME) General Classification (Except charge under \$150)
291	DME—Rental
292	DME—Purchase
299	DME—Other Equipment
540-549	Ambulance Services
900-909	Psychiatric/Psychological Treatments
910-919	Psychiatric/Psychological Services
940-949	Therapeutic Services
960-989	Professional Fees

AUTHORITY NOTE: Promulgated in accordance with R.S. 23:1034.2.

HISTORICAL NOTE: Promulgated by the Department of Labor, Office of Workers' Compensation, LR 19:54 (January 1993), repromulgated LR 19:212 (February 1993), amended LR 20:1299 (November 1994).

**§2529. Required Information for Billing Outpatient Services**

A. Itemization. Please itemize outpatient charges with the applicable revenue codes. The use of all inclusive ancillary revenue codes is not acceptable.

B. Reports. Supporting documentation of services rendered may be attached to billings for outpatient services. Such reports are:

1. emergency room reports;
2. operative reports, if surgery was performed; and
3. discharge summary, if surgery was performed.

AUTHORITY NOTE: Promulgated in accordance with R.S. 23:1034.2.

HISTORICAL NOTE: Promulgated by the Department of Labor, Office of Workers' Compensation, LR 19:54 (January 1993), repromulgated LR 19:212 (February 1993), amended LR 20:1299 (November 1994).

**§2531. Outpatient Services Not Billable on the UB-92**

A. The following services are not billable on the UB-92 Form unless they are customarily billed in that manner:

1. ambulance;
2. psychiatric/psychological treatments and services;
3. therapeutic services;
4. all professional services including those provided by salaried personnel that are customarily billed separately and those provided in connection with emergency room service. These type of professional services must be billed on the HCFA-1500 Form;
5. outpatient clinic services; and
6. all outpatient durable medical and prosthetic/orthotic items.

B. Separate sets of billing instructions/fee schedules have been developed for the following services:

1. professional services (including chiropractor and physical therapy);
2. durable medical equipment and supplies;
3. prosthetic and orthotic equipment;
4. medical transportation (ambulance);
5. respiratory therapy;
6. nursing/home health and attendant services; and
7. ambulance.

AUTHORITY NOTE: Promulgated in accordance with R.S. 23:1034.2.

HISTORICAL NOTE: Promulgated by the Department of Labor, Office of Workers' Compensation, LR 19:54 (January 1993), repromulgated LR 19:212 (February 1993), amended LR 20:1299 (November 1994).

**§2533. Outpatient Revenue Codes Not Billable on the UB-92**

A. The following revenue codes must be billed on the HCFA 1500 Form.

Revenue Code(s)	Description
274	Medical/Surgical Supplies Prosthetics
277	Medical/Surgical Supplies Take Home Oxygen
290	Durable Medical Equipment (DME) General Classification
291	DME-Rental
292	DME-Purchase
299	DME-Other Equipment
500-539	Outpatient Services, Clinic, Free-Standing Clinic and Osteopathic Services
570-599	Home Health Services
540-549	Ambulance Services
550-559	Skilled Nursing
820-859	Dialysis Service
860-879	Not Assigned
880-889	Miscellaneous Dialysis Services
900-909	Psychiatric/Psychological Treatments
910-919	Psychiatric/Psychological Services
940-949	Therapeutic Services
960-989	Professional Fees

AUTHORITY NOTE: Promulgated in accordance with R.S. 23:1034.2.

HISTORICAL NOTE: Promulgated by the Department of Labor, Office of Workers' Compensation, LR 19:54 (January 1993), repromulgated LR 19:212 (February 1993), amended LR 20:1299 (November 1994).

**§§2535-2537. Reserved.**

**§2539. Annual Maintenance**

A. To ensure that the reimbursement for the procedures are as fair as possible, the Office of Workers' Compensation will require the self insured employer or carrier to submit the following information for claims incurred in the preceding period. This information will be reviewed and any changes to the maximum allowable reimbursement rates will be published.

B. Information Required. The information required for calculation of the reimbursement schedule will include:

Information	Field Length	Type
FIP-Parish Code	3	Numeric
Provider Name	35	Alpha Numeric
Charge Amount	10	Numeric
Type of Service: Medical vs. Surgical*	30	Alpha
Length of Stay	4	Numeric
IP/OP indicator	1	Alpha
*The diagnosis/procedure code requiring the greatest resource consumption (severity) should be used to assign the correct category.		

C. Communication Format. The following is the current format, however, the Office of Workers' Compensation will

establish the format on an annual basis to facilitate the review:

1. magnetic tape;

a. tape 9-tract, 8.5 inch to 10.5 inch reels with silver mylar reflector (standard reels) with write-ring removed;

b. recording density—1600 or 6250 bytes per inch;

c. recording code—Extended Binary Coded Decimal Interchange Code (EBCDIC);

d. header record must identify submitter and position of each field in the record;

e. tape must have a leading tape mark and an end of file mark. The external label must identify the submitter, the date submitted, the tape number with identification of the total number of tapes submitted and the descriptive narrative of the information contained within the records;

2. diskettes:

a. a 5.25 inch diskette (floppy disk) that is IBM PC-DOS compatible with the following attributes:

i. double sided;

ii. double density;

iii. soft sectored;

iv. 9 sectors per track; and

v. 40 tracks per diskette;

b. a 3.5 inch, 720K diskette, that is IBM PC-DOS compatible with the following attributes:

i. double sided; and

ii. double density;

c. the external label must identify the submitter, the date submitted, the diskette number with identification of the total number of diskettes submitted and the descriptive narrative of the information contained within the records.

AUTHORITY NOTE: Promulgated in accordance with R.S. 23:1034.2.

HISTORICAL NOTE: Promulgated by the Department of Labor, Office of Workers' Compensation, LR 19:54 (January 1993), repromulgated LR 19:212 (February 1993), amended LR 20:1299 (November 1994).

**§§2541-2553. Reserved.**

**§2599. Appendix A—F.I.P.S. Area Codes**

Appendix A F.I.P.S. Area Codes			
001	Acadia	045	Iberia
003	Allen	047	Iberville
005	Ascension	049	Jackson
007	Assumption	051	Jefferson
009	Avoyelles	053	Jefferson Davis
011	Beauregard	055	Lafayette
013	Bienville	057	Lafourche
015	Bossier	059	LaSalle
017	Caddo	061	Lincoln
019	Calcasieu	063	Livingston
021	Caldwell	065	Madison
089	St. Charles	091	St. Helena
093	St. James	095	St. John the Baptist
097	St. Landry	099	St. Martin
101	St. Mary	103	St. Tammany
105	Tangipahoa	107	Tensas

023 Cameron	067 Morehouse	109 Terrebonne
025 Catahoula	069 Natchitoches	111 Union
027 Claiborne	071 Orleans	113 Vermillion
029 Condordia	073 Ouachita	115 Vernon
031 DeSoto	075 Plaquemines	117 Washington
033 East Baton Rouge	077 Pointe Coupee	119 Webster
035 East Carroll	079 Rapides	121 West Baton Rouge
037 East Feliciana	081 Red River	123 West Carroll
039 Evangeline	083 Richland	125 West Feliciana
041 Franklin	085 Sabine	127 Winn
043 Grant	087 St. Bernard	998 Out-of-State

AUTHORITY NOTE: Promulgated in accordance with R.S. 23:1034.2.

HISTORICAL NOTE: Promulgated by the Department of Labor, Office of Workers' Compensation, LR 19:54 (January 1993), repromulgated LR 19:212 (February 1993), amended LR 20:1299 (November 1994).

## Chapter 27. Utilization Review Procedures

### §2701. Statement of Policy

A. It is the intent of this rule to establish procedures and policies appropriate to the fulfillment of the powers, duties, and functions of the director of the Office of Workers' Compensation as set forth in R.S. 23:1291 (Act 938 of the 1988 Regular Session). R.S. 23:1291 empowers the director of the Office of Workers' Compensation:

1. "to resolve disputes over the necessity, advisability, and cost of proposed or already performed hospital care or services, medical or surgical treatment, or any nonmedical treatment recognized by the laws of this state as legal."; and

2. "to audit the specific medical records of the patient under treatment by any health care provider who has furnished services or treatment to a person covered by this Chapter, or the records of any person or entity rendering care, services, or treatment or furnishing drugs or supplies for the purpose of determining whether an inappropriate reimbursement has been made."

B. The law provides that after the promulgation of the medical treatment schedule, medical care, services, and treatment due, pursuant to R.S. 23:1203 et seq., by the employer to the employee incurred in the treatment of work-related injuries or occupational diseases [hereinafter referred to as "illness(es)"] shall mean care, services, and treatment in accordance with the medical treatment schedule.

1. It is therefore the policy of the Office of Workers' Compensation that medical bills for services should be sent to the carrier/self-insured employer for payment. Fees for covered services in excess of the amounts allowable under the terms of this schedule are not recoverable from the employer, insurer, or employee.

2. It is also deemed to be in the best interest of all of the parties in the system that fees for services reasonably performed and billed in accordance with the reimbursement schedule should be promptly paid. Not paying or formally contesting such bills by filing LWC-WC-1008 (disputed claim for compensation), with the Office of Workers'

Compensation within 60 days of the date of receipt of the bill may subject the carrier/self-insured employer to penalties and attorneys fees. Additionally, frivolous contesting of the bill may subject the carrier/self-insured employer to penalties and attorneys fees.

3. If claimant is receiving treatment for both compensable and noncompensable medical conditions, only those services provided in treatment of compensable conditions should be listed on invoices submitted to the carrier/self-insured employer unless the noncompensable condition (e.g., hypertension, diabetes) has a direct bearing on the treatment of the compensable condition. In addition, payments from private payers for noncompensable conditions should not be listed on invoices submitted to the carrier/self-insured employer. If a provider reasonably doesn't know the workers' compensation status, or the workers' compensation insurer has denied coverage, the provider won't be penalized for not complying with this rule. Upon notification or knowledge of workers' compensation eligibility, the provider will comply with these regulations prospectively.

4. Statements of charges shall be made in accordance with standard coding methodology as established by these rules, ICD-10-CM, ICD-10-PCS, HCPCS, and CPT-4 coding manuals. Unbundling or fragmenting charges, duplicating or over-itemizing coding, or engaging in any other practice for the purpose of inflating bills or reimbursement is strictly prohibited. Services must be coded and charged in the manner guaranteeing the lowest charge applicable. Knowingly and willfully misrepresenting services provided to workers' compensation claimants is strictly prohibited

5. Providers should take reasonable steps to ensure that only those services provided are billed to the carrier/self-insured employer. Violation of this provision may subject provider/practitioner to mandatory audit of all charges.

6. Bills for a particular charge item may not be included in subsequent billings without clear indication that they have been previously billed.

7. These rules must be used in addition to all the reimbursement rules.

AUTHORITY NOTE: Promulgated in accordance with R.S. 23:1291.

HISTORICAL NOTE: Promulgated by the Department of Employment and Training, Office of Workers' Compensation, LR 17:263 (March 1991), repromulgated LR 17:653 (July 1991), amended by the Workforce Commission, Office of Workers' Compensation Administration, LR 38:1030 (April 2012), LR 42:284 (February 2016).

### §2703. Introduction

A. Managed care activities are defined as a set of coordinated cost and utilization management activities by the carrier/self-insured employer to assure appropriate payment for health care services rendered to employees eligible for workers' compensation benefits in the state of Louisiana.



1. Pre-admission certification review is the cornerstone of utilization management. The pre-admission certification review notice (i.e., telephone call or written notification) is the claimant's entry into the benefits management system and triggers other utilization management functions. During pre-admission certification review, all utilization management activities can be coordinated. When cases are reviewed before hospitalization, this activity works to promote appropriate lengths of stay, discharge planning, and ambulatory care. The pre-admission certification program reviews and certifies, before hospitalization, that a proposed hospital admission is both medically necessary and appropriate. It is not a process of substituting judgement for that of the physician, but rather making a determination of what level of care is to be reasonable and necessary under the provisions of the Louisiana Workers' Compensation Act.

2. The following managed care activities required by the Louisiana Workers' Compensation Act are described: pre-admission certification, admission certification, continued stay review (including length of stay assignment), discharge planning, reporting standards and dispute resolution, ambulatory surgery, and second surgical opinion.

#### B. Definitions

*Admission Review*—the review of the medical necessity and appropriateness of hospital admissions. The review takes place after the admission, but within a stated time frame.

*Ambulatory Review*—the review of the medical necessity and appropriateness of services rendered to claimants in out-of-hospital settings (e.g., skilled nursing facility, home health services, physician's office, and outpatient ancillary services).

*Appeals Process*—a physician, hospital, or a claimant may appeal to the carrier/self-insured employer to change its decision regarding payment for an inpatient admission, an extension of a length of stay, a specific treatment or for a claim for medical services. The appeals process is formally written and includes specific time frames, how the process works and who makes the final decision. The final step in the appeals process is a review by the Office of Workers' Compensation Administration.

*Continued Stay Review*—the review of an ongoing inpatient hospitalization to assure that it remains the most appropriate setting for the care being rendered.

*Discharge Planning*—the process of assessing a claimant's need for medically appropriate treatment after hospitalization to effect an appropriate and timely discharge. The hospital and attending physician have major responsibility for this function with the carrier/self-insured employer promoting, monitoring, and assisting the hospital.

*Pre-Admission Certification Review*—the review and assessment of the medical necessity and appropriateness of hospital admissions before hospitalization occurs. The appropriateness of the site or level of care is assessed along with the timing and duration of the proposed hospitalization.

*Second Surgical Opinion*—second surgical opinion programs enable claimants to receive a consultation from a second physician before undergoing specified surgical procedures. The consulting opinion does not have to confirm the original recommendation for surgery, however, the decision to have or not to have the surgery remains with the claimant.

*Utilization Management Program*—a comprehensive set of integrated utilization management components including: pre-admission certification review, admission review, second surgical opinion, continued stay review, and discharge planning.

**AUTHORITY NOTE:** Promulgated in accordance with R.S. 23:1291.

**HISTORICAL NOTE:** Promulgated by the Department of Employment and Training, Office of Workers' Compensation, LR 17:263 (March 1991), repromulgated LR 17:653 (July 1991).

### §2705. Pre-Admission Certification

Editor's Note: The telephone number for the Office of Workers' Compensation has been changed to (225) 342-7555.

A. Pre-admission certification is the review and assessment of the medical necessity and appropriateness of non-emergency hospital admissions before hospitalization has occurred. The appropriateness of the site and the level of care is assessed along with the timing of the proposed admission. Actual payment for services is also contingent upon the carrier/self-insured employer's verification of:

1. claimant's entitlement to benefits at the time hospitalization actually occurs; and
2. statutory coverage for the care that is actually provided.

B. Application for pre-admission certification should be made prior to admission to the hospital unless the admission to the hospital is for a compensable illness or bodily injury that occurs without warning and requires immediate inpatient treatment to prevent death, disability or serious impairment of patient function. In the event an inpatient admission is for treatment of such a medical emergency, notification must be made to the carrier/self-insured employer within 48 hours of admission.

C. Louisiana Office of Worker's Compensation Administration shall support both ICD-9 and ICD-10 coding formats for a period of time after the compliance date. Claims shall be accepted with ICD-9 codes for service dates or discharge dates prior to the compliance date for pre-authorized services and/or treatment or timely filing requirements. If an authorization is requested on or before the compliance date, and the date of service is on or after October 1, 2015, healthcare professionals must submit an ICD-10 code. If an authorization is requested after the compliance date, the ICD-10 code will be required. The pre-admission certification process follows the sequence below.

1. The physician, hospital, or claimant must initiate the pre-admission certification process by calling the

## LABOR AND EMPLOYMENT

carrier/self-insured employer. The reviewer will request the following information:

- a. claimant name;
- b. Social Security number;
- c. date of injury;
- d. claimant's address;
- e. sex;
- f. claimant's date of birth;
- g. name of hospital;
- h. hospital address;
- i. anticipated admission date;
- j. admitting diagnosis (to include ICD-10-CM codes);\*
- k. expected length of stay;
- l. major procedures and related CPT/ICD-10-PCS codes;\*
- m. plan of treatment;
- n. complications or other factors requiring the inpatient setting;
- o. medical justification for inpatient admission;
- p. is surgery anticipated? If yes, procedure;
- q. is general anesthesia required;
- r. admitting physician's name;
- s. admitting physician's address;
- t. admitting physician's phone number;
- u. admitting physician's Tax ID or Social Security number; and
- v. caller's name and number.

\*The provider will provide descriptive/narrative information and the reviewer, representing the carrier/self-insured employer, will provide the ICD-10-CM, ICD-10-PCS and/or CPT-4 codes.

### D. Pre-Admission Review Procedures

1. The carrier/self-insured employer must be able to administer a program where pre-admission certification review is initiated by the physician, hospital or claimant. Once the caller has made the first phone call to notify the carrier/self-insured employer of proposed hospitalization, the carrier/self-insured employer will follow through with phone calls and written confirmations to the claimant, physician and hospital.

2. Pre-admission certification review is primarily conducted by telephone during normal business hours (8 a.m. to 4:30 p.m. Central Time, Monday through Friday, excluding legal holidays) to assure quick responses. Written requests for pre-admission certification may be processed by the carrier/self-insured employer on a case by case basis.

3. The Office of Workers' Compensation Administration will require annual reports on all workers' compensation medical review activity. Automated software support for the review process is recommended in order to assure timely responses, uniform administration, and complete data gathering.

4. All non-emergency hospital admissions must be reviewed using nationally accepted criteria designed to assess the need for the acute level of care. The Appropriateness Evaluation Protocol (AEP) and the Intensity/Severity/Discharge (ISD) criteria are the two most prominent nationally accepted criteria for admissions.

- a. The AEP manual is available from:

Utilization Management Assoc.  
888 Worcester Street  
Wellesly, MA 02811  
Phone: (617) 237-6822

- b. The ISD manual is available from:

InterQual  
44 Lafayette  
North Hampton, NH 03862  
Phone: (603) 964-7255

5. When the medical necessity of a proposed hospitalization is approved or certified, an expected length of stay is assigned. The length of stay is based on statistical norms developed by the Professional Activities Study (PAS) of the Commission on Professional and Hospital Activities, Southern Region.

- a. The PAS is available from:

CPHA Publications  
1968 Green Road  
Box 1809  
Ann Arbor, MI 48106  
Phone: (800) 521-6210

6.a. The carrier/self-insured employer shall use registered nurses for the initial review of recommended hospitalization. Registered nurses will use written criteria provided in Paragraph D.4 above to assess proposed hospitalizations. Physicians must review all questionable cases and make the carrier/self-insured employer decisions on all denials of certifications.

b. Within five calendar days of receipt of the request, a response must be generated in writing as to whether or not the admission is approved or denied. Verbal response will be given within two working days from the time of the request followed by the written response. Copies of the written response will be sent to the attending physician, the hospital, and the claimant and must notify the parties of the right to appeal and the appeal process. Sample letters are enclosed as Clauses E.1.b.iii and iv.

7.a. An appeals process must be available for reconsideration of any denial decisions. If the admitting physician, hospital, or claimant desires to appeal a denial of an admission or continued stay request, the appeals process

is initiated by contacting the carrier/self-insured employer by telephone or other immediate means following receipt of the denial. After the appeal request is received, it will be referred to the carrier/self-insured employer medical director or physician consultant in the appropriate specialty if required. The carrier/self-insured employer medical director or physician consultant will review the available information regarding the request and make a decision concerning the appeal within 48 hours of receipt/communication of the appeal.

b. If the carrier/self-insured employer medical director decision is an approval of the appeal the admitting physician and hospital will be immediately notified via telephone and follow up by letter will be sent to the physician, claimant, and hospital.

c. If the carrier/self-insured employer medical director's decision is a denial the carrier/self-insured employer will notify the admitting physician and hospital and will immediately submit in writing the denial and case documentation by fax to the director of the Office of Workers' Compensation for review at (225) 342-6556.\*\* The material should be clearly identified as a denial of hospital admission and should be addressed "Attention: Medical Manager, Office of Workers' Compensation." The director will immediately review the case and will notify the carrier/self-insured employer, admitting physician, and hospital by telephone of his agreement or disagreement with the denial decision. Follow-up notification will be sent to the claimant, carrier/self-insured employer, hospital, and admitting physician by certified mail return receipt requested. Any party who disagrees with the director's resolution may file a Disputed Claim for Compensation Form (LDOL-WC-1008), available from the Office of Workers' Compensation Administration as otherwise provided by law.

8. Review nurses should coordinate related managed care activities with the pre-admission certification request. For example, compliance with a second surgical opinion

component should be checked during the physician's initial call.

9. The review process is also used to identify and refer cases for discharge planning.

10. The carrier/self-insured employer will provide written notification of the review decision to the claimant, attending physician and the hospital.

11.a. The carrier/self-insured employer must maintain appropriate internal documentation of each request for pre-admission certification to verify the process and the decision for claims processing and reporting purposes.

b. If a patient does not enter the hospital on the proposed date of admission (or within 15 days following that date) re-certification is required. In such cases the caller should contact the carrier/self-insured employer to re-affirm the previously submitted pre-certification data and have the admission re-certified.

#### E. Pre-Admission Review Preparation

##### 1. Preparation

a. Educational Program for Providers. The carrier/self-insured employer will develop and distribute provider notices announcing the pre-admission certification program, describing the reasons for implementation and operation, including an explanation of the appeals process. This notice of the pre-admission certification program may be included in local carrier/self-insured employer provider newsletters.

b. Pre-Admission Review Forms. The carrier/self-insured employer may use the samples attached (Exhibit 1 and 2) or develop forms to capture pertinent patient and provider information during the pre-admission certification activity. These forms may be identical to those used by the carrier/self-insured employer for their other business. However, they should capture the statistical data elements required by the Office of Workers' Compensation Administration.

LABOR AND EMPLOYMENT

i. Exhibit 1, Pre-Certification Activity Sheet

EXHIBIT 1 PRE-CERT ACTIVITY SHEET																							
NAME OF CLAIMANT		SOCIAL SECURITY NUMBER		DATE OF INJURY																			
ADDRESS OF CLAIMANT		CITY	STATE		ZIP CODE																		
SEX <input type="checkbox"/> MALE <input type="checkbox"/> FEMALE		CLAIMANT'S DATE OF BIRTH																					
NAME OF HOSPITAL																							
ADDRESS		CITY		STATE																			
ADDRESS		CITY		STATE																			
PROPOSED DATE OF ADMISSION		DIAGNOSIS AND/OR ICDA & CM		EXPECTED LENGTH OF STAY																			
MAJOR PROCEDURE		PLAN OF TREATMENT		COMPLICATIONS																			
MEDICAL JUSTIFICATION																							
PROVIDER NUMBER		PRIMARY PHYSICIAN		CALLERS NAME AND NUMBER																			
ATTENDING PHYSICIAN'S NAME				PHONE NUMBER																			
ADDRESS		CITY		STATE																			
ADDRESS		CITY		STATE																			
IS SURGERY ANTICIPATED? IF YES, PROCEDURES <input type="checkbox"/> YES <input type="checkbox"/> NO			IS GENERAL ANESTHESIA REQUIRED? <input type="checkbox"/> YES <input type="checkbox"/> NO																				
<table style="width: 100%; border: none;"> <tr> <td style="width: 20%; border: none;">_____</td> <td style="width: 10%; border: none;">75%</td> <td style="width: 10%; border: none;">90%</td> <td style="width: 20%; border: none;">_____ DAYS</td> <td style="width: 20%; border: none;">_____</td> <td style="width: 10%; border: none;">_____</td> </tr> <tr> <td style="border: none;">DATE</td> <td style="border: none;">( )</td> <td style="border: none;">( )</td> <td style="border: none;">PAST 75%</td> <td style="border: none;">CERTIFICATGION NO.</td> <td style="border: none;"></td> </tr> <tr> <td style="border: none;">APPEAL</td> <td style="border: none;">OUT PT.</td> <td style="border: none;">MMC/SNF</td> <td style="border: none;">RECERT</td> <td style="border: none;">CHANGES</td> <td style="border: none;">N &amp; M</td> </tr> </table>						_____	75%	90%	_____ DAYS	_____	_____	DATE	( )	( )	PAST 75%	CERTIFICATGION NO.		APPEAL	OUT PT.	MMC/SNF	RECERT	CHANGES	N & M
_____	75%	90%	_____ DAYS	_____	_____																		
DATE	( )	( )	PAST 75%	CERTIFICATGION NO.																			
APPEAL	OUT PT.	MMC/SNF	RECERT	CHANGES	N & M																		
<b>RECERTS</b>  1. NO. OF RECERT DAYS _____ NO. OF RECERT DAYS TO SHOW _____ FILE    D C    ACTUVE _____ DATE _____  2. NO. OF RECERT DAYS _____ NO. OF RECERT DAYS TO SHOW _____ FILE    D C    ACTUVE _____ DATE _____  3. NO. OF RECERT DAYS _____ NO. OF RECERT DAYS TO SHOW _____ FILE    D C    ACTUVE _____ DATE _____  4. NO. OF RECERT DAYS _____ NO. OF RECERT DAYS TO SHOW _____ FILE    D C    ACTUVE _____ DATE _____  5. NO. OF RECERT DAYS _____ NO. OF RECERT DAYS TO SHOW _____ FILE    D C    ACTUVE _____ DATE _____			<b>CHANGES</b>  DATE OF SERVICE _____  <b>CHANGE</b>																				



LABOR AND EMPLOYMENT

ii. Exhibit 3, Pre-Admission Approval Letter

Re: Patient:  
Pre-Admission Certification No.:  
Claimant No.:  
Date of Service:  
Hospital:

The admission to the hospital referenced above has been initially approved for (number of days) days.

IT IS IMPORTANT FOR YOU TO KNOW THAT.....

this approval of the inpatient hospital setting is based on information provided by the above listed hospital and/or physician.

THE DETERMINATION OF ACTUAL BENEFITS.....

can only be made upon receipt of the completed claim. Payment for the services received is subject to statutory limitations. Eligibility is dependent upon:

1. the medical necessity for the services provided; and
2. the work-relatedness of the illness or injury.

IF THE CLAIMANT REQUIRES CONTINUED HOSPITALIZATION BEYOND THE NUMBER OF DAYS APPROVED.....

the admitting physician or authorized hospital representative should contact the carrier/self-insured employer at (phone number) on or before the above days expire.

BENEFITS FOR SERVICES RENDERED DURING ADDITIONAL HOSPITAL DAYS NOT CERTIFIED MAY BE DENIED.

iii. Exhibit 3-B, Pre-Admission Denial Letter

Re: Patient:  
Pre-Certification No.:  
Contract No.:  
Date of Service:  
Hospital:

Dear (claimant/physician/provider)

The medical director for (carrier/self-insured employer) has carefully reviewed the pre-certification request for admission to the hospital referenced above.

Based upon information obtained, it has been determined that the medical necessity of the admission has not been documented.

As a result of the findings, this letter is to notify you that (carrier/self-insured employer) will not consider payment for the requested admission.

If you disagree with this decision, you may appeal in accordance with the guidelines attached.

Sincerely,

2. Implementation

a. Telephone Inquiry Service. Telephone numbers should be published in educational materials and standardized form letters to the physicians, hospitals, and claimants. This telephone service allows for prompt response

to requests for review and to general inquiries about the review process.

b. Appropriate Staff and Documentation for Program Management of Certified, Denied and Appealed Admissions. Registered nurses and physicians are the

recommended staff for processing of pre-admission certification requests and inquires. Procedures must be available for timely review of appealed or denied admissions by a physician (a psychiatrist for mental illness or substance abuse admissions). Program procedures should be routine and documented.

3. Evaluation

a. Data Collection. Pre-admission certification documentation should be linked to the payment system to properly process inpatient claims. The pre-admission certification documentation should be retrievable on a claim-by-claim basis for compilation and classification of activity performance.

b. Carrier/Self-Insured Employer Data Reporting. Carrier/self-insured employer will be required to collect the following data according to the Office of Workers' Compensation Administration requirements.

Information	Positions	Type
ICD-10-CM	5/7	Numeric
Provider Name	30	Alpha
Provider Street Address	30	Alpha Numeric
Parish Code for Provider of Service (Use Standard FIPS code, see Exhibit 5)	3	Numeric
Place of Treatment	1	Alpha Numeric
Type of Facility*	6	Numeric
Type of Service: Medical vs. Surgical	1	Alpha Numeric
Claimant Name	30	Alpha
Claimant Social Security Number	9	Numeric
Length of Stay	4	Numeric

\*See "Type Facility Codes" in Exhibit 6.

c. Exhibit 5

F.I.P.S. Area Codes		
001 Acadia	045 Iberia	089 St. Charles
003 Allen	047 Iberville	091 St. Helena
005 Ascension	049 Jackson	093 St. James
007 Assumption	051 Jefferson	095 St. John the Baptist
009 Avoyelles	053 Jefferson Davis	097 St. Landry
011 Beauregard	055 Lafayette	099 St. Martin
013 Bienville	057 Lafourche	101 St. Mary
015 Bossier	059 La Salle	103 St. Tammany
017 Caddo	061 Lincoln	105 Tangipahoa
019 Calcasieu	063 Livingston	107 Tensas
021 Caldwell	065 Madison	109 Terrebonne
023 Cameron	067 Morehouse	111 Union
025 Catahoula	069 Natchitoches	113 Vermillion
027 Claiborne	071 Orleans	115 Vernon
029 Concordia	073 Ouachita	117 Washington
031 DeSoto	075 Plaquemines	119 Webster
033 East Baton Rouge	077 Pointe Coupee	121 West Baton Rouge
035 East Carroll	079 Rapides	123 West Carroll
037 East Feliciana	081 Red River	125 West Feliciana
039 Evangeline	083 Richland	127 Winn
041 Franklin	085 Sabine	
043 Grant	087 St. Bernard	998 Out-of-State

d. Exhibit 6a

Type Of Facility Code General Type Provider (Position 1 and 2)			
00	Not Licensed	36	Alcohol/Drug Rehab Center (CDU)
01	Hospital*	37	Special Care Unit-Behavior Modification
02	Skilled Nursing Facility*	38	Outpatient Surgical Unit (Hospital Based)
03	Custodial Nursing/Rehab Facility	39	Hospice
04	Physician (M.D.)	40	Licensed Massage Therapist (MA)
05	Home Health Agency*	41	Doctor of Education (EdD)
06	Dentist (D.M.D.-D.D.S.)	42	Lithotripter Facility
07	Pharmacy (not hospital)	43	Master of Science (M.S.)
10	Ambulance (non-hospital)	44	Certified Substance Abuse Counselor (CSAC)
11	Podiatrist (D.P.M.)	45	Counseling and Biofeedback Therapy
12	Psychologist (Ph.D.)	46	Family Counseling, Pastoral Counseling
13	Chiropractor	47	Oriental Medical Doctor (O.M.D.)
14	Osteopath (D.O.)	48	Certified Surgical Technician (C.S.T.)
15	Registered Nurse (R.N.)	49	Doctor of Divinity (D.D.)
16	Surgical Center (free standing)	50	Private Duty Nursing
17	Radiation Center (free standing)	51	Multiple Specialties
18	Renal Dialysis Center (free standing)	52	Radiology (Non-Hospital)
19	Certified Registered Nurse Anesthetist (CRNA)	53	VA/Military Hospital/ Acute Care
20	Physical Therapist	54	VA/Military Hospital/ Psychiatric
21	Optometrist	55	VA/Military Hospital/CDU
22	Registered Sitter	56	VA/Military Hospital/SNF
23	Optical Dispensary	57	VA/Military Hospital/HHA
24	Medical/Surgical Supply Organization	58	VA/Military Hospital/ Ambulatory Surgery
25	Other Para-Medical	59	Registered Dietitian (R.D.)
26	Hearing Aid Dealers	60	Cardiac Catheterization Facility
27	Audiologist	61	Residential Treatment Center
28	Speech Pathologist	62	Eating Disorder Treatment Facilities
28	Social Worker	63	Physician's Assistant
30	Licensed Practical Nurse	64	Third Party Liability
31	Public Conveyance	65	Emergency Room Physicians
32	Rehabilitation Center	66	Medical Staff Services
33	Pre-admit Testing Facility	67	Mental Health Clinic
34	Alcohol/Drug Rehabilitation Center (CDU) Detox Services Only	68	Sperm Banks
35	Psychiatric Hospitals-Inpatient and Outpatient	69	Home Infusion Therapy
*If position 1 and 2 are 01, 02, or 05, use the additional codes on the next page, otherwise, the remaining four positions of the Type Facility Code may be filled with zeros (0's).			

e. Exhibit 6b

Type of Facility Code			
Specific Type Provider (Position 3 and 4)			
<b>If General Type (Position 1 and 2) is 01:</b>			
01	General Short Term	03	Official Health Agency
02	General Long Term	04	Rehab. Facility Based Program
03	TB	05	Hospital Based Program
04	Psychiatric	06	S.N.F. Based Program
05	Chronic Disease	07	Proprietary
06	Specialty Short Term	08	Other
07	Specialty Long Term	<b>Ownership/Management (Position 5 and 6)</b>	
08	Christian Science	<b>If General Type (Position 1 and 2) is 01 or 02 or 05:</b>	
09	All Others	01	Church
<b>If General Type (Position 1 and 2) is 02:</b>			
		02	Other Than Church
01	Skilled Nursing Facility	03	Proprietary
02	E.C. Unit of Hospital	04	State
03	E.C. Unit of Rehabilitation Center	05	Parish (County)
04	E.C. Unit of Domiciliary Institution	06	City
05	Distinct part of S.N.F.	07	City-Parish (County)
06	Christian Science	08	Hospital District
07	Combined with Intermediate Care	09	P.H.S. (Fed. Gov't.)
08	Intermediate Care Facility Only	10	Other than P.H.S. (Fed Gov't.)
09	Other	11	All Other
<b>If General Type (Position 1 and 2) is 05:</b>			
01	Visiting Nurse Association		
02	Combined Govt. and Vol. Agency		

AUTHORITY NOTE: Promulgated in accordance with R.S. 23:1291.

HISTORICAL NOTE: Promulgated by the Department of Employment and Training, Office of Workers' Compensation, LR 17:263 (March 1991), repromulgated LR 17:653 (July 1991), amended by the Workforce Commission, Office of Workers' Compensation Administration, LR 42:284 (February 2016).

**§2707. Admission and Continued Stay Review**

Editor's Note: The telephone number for the Office of Workers' Compensation has been changed to (225) 342-7555.

A. In those instances when an emergency hospital admission is involved, an admission review is conducted. Admission review determines the medical appropriateness of the admission and utilizes the same techniques employed in pre-admission certification review such as reviewing all pertinent medical information against a set of accepted medical criteria to evaluate the need for hospital level of care. Non-emergency admissions that have not been pre-certified by pre-admission certification review are also monitored through admission review. If the admission is considered appropriate, a reasonable length of stay is assigned using a set of standard criteria. The admission review and continued stay review follow the sequence below.

B. Continued stay review is the review of the appropriateness and necessity of continued hospitalization while the patient is still in the hospital. The review is conducted using acceptable medical criteria to evaluate the appropriateness of continued hospital level of care. The same criteria used in pre-admission certification review are used during continued stay review. The day before the expected discharge date, the case is reviewed to determine if hospital level of care is still needed. If additional inpatient care is necessary, review personnel will authorize an extension of the length of stay.

C. Continued stay review is an integral part of managed care. During continued stay review, review personnel can identify cases that will benefit from individual case management. Continued stay review permits the review personnel to become aware of changes in a patient's condition or slow recovery which may necessitate a longer hospital stay.

**D. Admission and Continued Stay Review Procedures**

1. The carrier/self-insured employer will automatically review the necessity for continued hospitalization the day before the initial length of stay assigned expires without claimant initiation responsibility. The responsibility to request an extension may be delegated to the hospital if requested by the hospital and agreed to in writing by the carrier/self-insured employer. If the party who has the responsibility for initiating the continued stay review fails to do so, they will be responsible for the cost of any subsequent care provided.

2. Continued stay review will include telephone discussions with the hospital or physician if the information required is not available from the hospital. All pertinent information necessary to determine if continued hospitalization is medically necessary and appropriate will be gathered (i.e., current medications and methods of administration used, frequency, lab values, and results of diagnostic tests). If re-certification is appropriate, additional days are assigned based upon statistical norms indicated in the PAS manual using the next higher percentile adjusted by the medical judgement of the reviewer, if applicable. This process will continue until the patient is discharged or until documentation no longer supports the medical necessity for inpatient services. If re-certification is not medically necessary or appropriate based upon documentation reviewed, the medical director will issue a denial to the physician, claimant, and hospital by the close of business (4:30 p.m. Central Time) on the day of the review.

3. All nonelective acute care hospital admissions including emergencies, psychiatric admissions, and all extended hospitalizations are reviewed using nationally accepted criteria designed to assess the need for hospital level of care. The Appropriateness Evaluation Protocol (AEP) and the Intensity/Severity/Discharge (ISD) criteria are the two most prominent nationally accepted criteria for admissions.

4. Automated software support for the review process is recommended in order to assure timely responses, uniform



administration and complete data gathering. Computer prompts may be especially important in following up on length of stay assignments and assuring timely continued stay review.

5. Registered nurses use written criteria to assess the need for continued stays in the hospital. Physicians review all questionable cases and will make the final carrier/self-insured employer decisions on all denials of certification.

6.a. An appeals process must be available for reconsideration of any denial decisions. If the admitting/treating physician, hospital, or claimant desires to appeal a denial of an admission or continued stay request, the appeals process is initiated by contacting the carrier/self-insured employer by telephone or other immediate means following receipt of the denial. After the appeal request is received, it will be referred to the carrier/self-insured employer medical director or physician consultant. The carrier/self-insured employer medical director or physician consultant will review the available information regarding the request and make a decision concerning the appeal within 48 hours of receipt/communication of the appeal.

b. If the carrier/self-insured employer medical director's decision is an approval of the appeal the admitting/treating physician and hospital will be immediately notified via telephone and follow up by letter will be sent to the physician, claimant, and hospital.

c. If the carrier/self-insured employer medical director's decision is a denial the carrier/self-insured employer will notify the admitting/treating physician and hospital and will immediately submit in writing the denial and case documentation by fax to the director of the Office of Workers' Compensation for review at (225) 342-6556.\*\* The material should be clearly identified as a denial of an admission or continued hospital stay request and should be addressed "Attention: Medical Manager, Office of Workers' Compensation." The director will immediately review the case and will notify the carrier/self-insured employer, the admitting/treating physician, and hospital by telephone of his agreement or disagreement with the denial decision. Follow-up notification will be sent to the claimant, carrier/self-insured employer, hospital, and admitting/treating physician by certified mail return receipt requested. Any party who disagrees with the director's resolution may file a Disputed Claim for Compensation

Form (LDOL-WC-1008), available from the Office of Workers' Compensation Administration as otherwise provided by law.

7. The review process is also used to identify and refer cases for discharge planning.

8. The program includes written notification of the continued stay review decision to the claimant, physician and the hospital.

9. The carrier/self-insured employer maintains appropriate internal documentation of each request for continued stay review to verify the process and the decision for claims processing and reporting purposes.

#### E. Admission And Continued Stay Review Preparation

##### 1. Preparation

a. Educational Program for Providers. The carrier/self-insured employer will maintain and make available to the provider information regarding the admission and continued stay review certification program, describing the reasons for implementation and operation, including an explanation of the appeals process. This notice of the admission and continued stay review program may be included in local carrier/self-insured employer provider newsletters.

b. Admission and Continued Stay Review Forms. The carrier/self-insured employer may use samples (Exhibit 1 and 2, Clauses E.1.d.i and ii) or develop forms to capture pertinent patient and provider information during the admission and continued stay review activity. These forms may be identical to those used by the carrier/self-insured employer for their other business, however, they should capture the statistical data elements required by the Office of Workers' Compensation Administration.

c. Standardized Form Letters. The carrier/self-insured employer will develop letters announcing the results of the admission and continued stay review process to:

- i. claimant;
- ii. the admitting/treating physician; and
- iii. the hospital, with appeals process information where necessary.

LABOR AND EMPLOYMENT

- d. Exhibits of Form Letters
  - i. Exhibit 3-A—Continued Stay Approval Letter

Re: Patient:  
Pre-Admission Certification No.:  
Claimant No.:  
Date of Service:  
Hospital:

Additional days to the hospital referenced above have been approved based upon a determination of medical necessity for continued inpatient care. A total of (indicate number of days) days is available for this hospital stay.

IT IS IMPORTANT FOR YOU TO KNOW THAT ...  
This approval of the inpatient hospital setting is based on information provided by the above listed hospital and/or physician.

THE DETERMINATION OF ACTUAL BENEFITS ...  
Can only be made upon receipt of completed claim. Payment for the services received is subject to statutory limitations. Eligibility is dependent upon:  
1. the medical necessity for the services provided; and  
2. the work-relatedness of the illness or injury.

IF THE CLAIMANT REQUIRES CONTINUED HOSPITALIZATION BEYOND THE NUMBER OF DAYS APPROVED ...  
The admitting physician or authorized hospital representative should contact the carrier/self-insured employer at (phone number) on or before the above days expire.

BENEFITS FOR SERVICES RENDERED DURING ADDITIONAL HOSPITAL DAYS NOT CERTIFIED MAY BE DENIED.

- ii. Exhibit 3-C—Continued Stay Denial Letter

Re: Patient:  
Pre-Certification No.:  
Contract No.:  
Date of Service:  
Hospital:

Dear (claimant/physician/provider)

The medical director has reviewed carefully your current medical status and, based upon the information obtained, has determined that the medical necessity of further hospitalization has not been documented.

Charges for inpatient services after (date), at the hospital referenced above will not be considered for payment.

If you disagree with this decision, you may appeal in accordance with the guidelines attached.

Sincerely,

2. Implementation

a. Telephone Inquiry Service. Telephone numbers should be published in educational materials and standardized form letters to the physicians, hospitals, and claimants. This telephone service allows for prompt response to requests for review and to general inquires about the review process.

b. Appropriate Staff and Documentation for Program Management of Certified, Denied, and Appealed Admissions. Registered nurses and physicians are the recommended staff for processing of admission and continued stay review requests and inquires. Procedures

must be available for timely review of appealed or denied admissions by a physician (a psychiatrist for mental illness or substance abuse admissions). Program procedures should be routine and documented.

3. Evaluation

a. Data Collection. Admission and continued stay review documentation should be linked to the claims system to properly process inpatient claims. The admission and continued stay review documentation should be retrievable on a claim-by-claim basis for compilation and classification of activity performance.

b. Carrier/Self-Insured Employer Data Reporting. Carrier/self-insured employer will be required to collect data according to the Office of Workers' Compensation Administration requirements:

Information	Positions	Type
ICD-10-CM	5/7	Numeric
Provider Name	30	Alpha
Provider Street Address	30	Alpha Numeric
Parish Code for Provider of Service (Use Standard FIPS code, see Exhibit 5)	3	Numeric
Place of Treatment	1	Alpha Numeric
Type of Facility*	6	Numeric
Type of Service: Medical vs. Surgical	1	Alpha Numeric
Claimant Name	30	Alpha
Claimant Social Security Number	9	Numeric
Length of Stay	4	Numeric

\* See "Type Facility Codes" in Exhibit 6.

AUTHORITY NOTE: Promulgated in accordance with R.S. 23:1291.

HISTORICAL NOTE: Promulgated by the Department of Employment and Training, Office of Workers' Compensation, LR 17:263 (March 1991), repromulgated LR 17:653 (July 1991), amended by the Workforce Commission, Office of Workers' Compensation Administration, LR 42:284 (February 2016).

**§2709. Discharge Planning**

Discharge planning is the process of assessing a patient's need for treatment after hospitalization and effecting an appropriate and timely discharge. The hospital has major responsibility for this function with the carrier/self-insured employer promoting, monitoring, and assisting the hospital.

**A. Discharge Planning Procedures**

1. Discharge planning is primarily the responsibility of the hospital.

2. The carrier/self-insured employer supports discharge planning by identifying and referring patients who may need discharge planning, by assisting the hospital with information on statutory coverage and alternative providers, and by monitoring hospitals to assure that appropriate discharge planning services are provided.

3. Discharge planning cases are identified primarily by the hospital. These services may not be duplicated by the carrier/self-insured employer if they are provided by the hospital. However, in addition, the carrier/self-insured employer identifies cases through pre-admission certification, admission review, continued stay review, and other managed care activities.

4. The carrier/self-insured employer requires appropriate hospital documentation on cases processed through discharge planning.

**B. Discharge Planning Preparation**

**1. Preparation**

a. Discharge Planning Information. The carrier/self-insured employer will capture pertinent patient and provider data during the discharge planning activity. This information may be identical to that used by the carrier/self-insured employer for their other business, however it should include

the statistical data elements required by the Office of Workers' Compensation Administration.

b. Screening for Cases. The carrier/self-insured employer should identify the cases that are most likely to require discharge planning. This process can be initiated during the pre-admission certification activity to identify cases and to notify the hospital to begin discharge planning as soon as possible. The sooner the hospital discharge planner knows the patient's needs, the more likely it is that unnecessary days will be avoided.

**2. Implementation**

a. Telephone Inquiry Service. Telephone numbers should be published in educational materials and standard form letters to hospitals and claimants. This telephone service should provide for prompt response to general inquiries about the discharge planning process.

b. Monitoring the Hospital. The carrier/self-insured employer should monitor the hospital's discharge planning activity on a case-by-case basis and an aggregate basis at regular intervals. Monitoring ensures that Louisiana workers' compensation claimants receive quality care. As part of the monitoring effort, the carrier/self-insured employer may require documentation from the medical records or abstract material on patients. Documentation should include information on the cases the hospital has seen, the discharge planning activity, the results of the activity and the problems encountered.

AUTHORITY NOTE: Promulgated in accordance with R.S. 23:1291.

HISTORICAL NOTE: Promulgated by the Department of Employment and Training, Office of Workers' Compensation, LR 17:263 (March 1991), repromulgated LR 17:653 (July 1991).

**§2711. Second Surgical Opinion**

A. When surgery has been recommended by the treating physician, the carrier/self-insured employer is entitled to obtain a second professional opinion from a physician chosen by the carrier/self-insured employer. Regardless of the second surgical opinion outcome, the claimant remains free to elect not to undergo surgery after the consultation. The carrier/self-insured employer is responsible for informing the claimant when a second surgical opinion is required and for referring the claimant to a second surgical opinion physician. This Program is designed to reduce unnecessary surgeries and to provide the claimant with possible alternate courses of treatment so that he or she can make an informed decision.

**B. Second Surgical Opinion Procedures**

1. The following is a list of surgical procedures that usually require a second opinion.

Spinal Surgery	Foot Surgery
Gastrectomy	Hemorrhoidectomy
Coronary Artery Bypass	Varicose Vein Surgery
Knee Surgery	Traumatic Cataract Surgery
Nasal Surgery	Joint Replacement

LABOR AND EMPLOYMENT

2. The carrier/self-insured employer should have in place a process to waive second surgical opinions on the basis of defined criteria.

3. The carrier/self-insured employer shall develop manual procedures or develop an automated system for administering program requirements, selecting consultants, documenting claimant compliance with the program, and efficiently handling claimant and physician contacts.

4. The second surgical opinion consultation and any tests necessary for the second surgical opinion consultant to render an opinion on the proposed surgery are to be paid by carrier/self-insured employer.

AUTHORITY NOTE: Promulgated in accordance with R.S. 23:1291.

HISTORICAL NOTE: Promulgated by the Department of Employment and Training, Office of Workers' Compensation, LR 17:263 (March 1991), repromulgated LR 17:653 (July 1991).

**§2713. Ambulatory Surgery**

A. Ambulatory surgery refers to a program which recommends that specified surgical procedures be performed on an outpatient basis. The program is designed to reduce unnecessary hospitalizations and to shift care to less costly settings if medically appropriate. The surgeon is responsible for following the specified guidelines for procedures which should be performed in an outpatient setting.

B. Ambulatory Surgery Procedures

1. The following is a list of surgical procedures and tests that are classified as primarily outpatient procedures not requiring hospitalization under normal circumstances.

Arthroscopy	Brush Biopsy of Stomach
Blood Transfusions	Carpal Tunnel Release
Closed Reduction Nasal Fracture	Cystoscopy
Closed Reduction of Dislocation or Fracture	Dx Radiological Procedures in Absence of Acute Admittable Illness
Dx Ultrasound	Esophagoscopy
Exploration Tendon Sheath—Hand	Excision Lesion Tendon Sheath—Hand
Excision Lesion Tendon Sheath	Fiberoptic Bronchoscopy
Flex Fiberoptic Colonoscopy	Gastroscopy
Lid Reconstruction	Laryngoscopy/ Tracheoscopy
Large Bowel Endoscopy	Laparoscopy
Other Larynx Diagnostic Procedures	Other Fusion of Toe
Other Skin and Subcutaneous Incision/Drainage	Other Local Destruction of Skin
Peripheral Nerve Biopsy	Plastic Repair External Ear
Partial Osteotomy	Sinus Puncture for Lavage
Surgical Tooth Extraction	Small Bowel Endoscopy—via existing surgical ostomy
Skin Incision and Foreign Body Removal	Skin and Subcutaneous Biopsy
Skin Suture	Tooth Extraction
Turbinate Fracture	Tenotomy of Hand
Total Osteotomy—Digit	Turbinectomy by Diathermy/Cryosurgery
The Office of Workers' Compensation may expand this list pursuant to its rulemaking authority.	

2. The carrier/self-insured employer should not waive ambulatory surgeries except on the basis of defined criteria, which must include at least the following:

a. presence of other documented medical problems that make prolonged pre-operative or post-operative observation medically necessary;

b. inability to provide proper post-operative care at home; and

c. likelihood that another major surgical procedure might follow the initial procedure.

3. The carrier/self-insured employer should have an automated system for administering program requirements and documenting provider compliance with the program.

C. Ambulatory Surgery Preparation

1. Preparation

a. It is important to stress to the provider that the intent of the program is not to reduce the quality of care and to explain that carrier/self-insured employer consultant physicians are available to discuss cases for which the attending physician feels the surgery must be performed on an inpatient basis.

b. Drawing on the strength of existing physician relations, the carrier/self-insured employer needs to stress continued cooperation between the carrier/self-insured employer physician consultant and the attending physician. In addition, the carrier/self-insured employer should develop ongoing physician communications, such as newsletters and attendance at community physician gatherings.

2. Implementation

a. Telephone Inquiry Service. Telephone numbers should be published in educational materials and standard form letters to physicians and claimants. This telephone service should provide for prompt response to inquiries regarding ambulatory surgery.

b. Appropriate Staff and Documentation. Registered nurses and physicians are the recommended staff for processing of ambulatory surgery requests and inquiries. Procedures must be available for timely review of cases which providers believe cannot be safely performed in an outpatient setting. Program procedures should be routine and documented.

3. Evaluation

a. Data Collection. Ambulatory surgery information should be linked to the claims system to properly process surgical claims. Ambulatory surgery elements should be retrievable on a claim-by-claim basis for compilation and classification of activity performance.

b. Plan Data Reporting. Carriers will be required to collect data for report preparation as outlined in the billing and maintenance section of the Office of Workers' Compensation Reimbursement Manual.

AUTHORITY NOTE: Promulgated in accordance with R.S. 23:1291.

HISTORICAL NOTE: Promulgated by the Department of Employment and Training, Office of Workers' Compensation, LR 17:263 (March 1991), repromulgated LR 17:653 (July 1991).

### **§2715. Medical Treatment Schedule Authorization and Dispute Resolution**

A. Purpose. It is the purpose of this Section to facilitate the management of medical care delivery, assure an orderly and timely process in the resolution of care-related disputes; identify the required medical documentation to be provided to the carrier/self-insured employer to initiate a request for authorization as provided in R.S. 23:1203.1(J); and provide for uniform forms, timeframes, and terms for suspension of prior authorization process, withdrawal of request for authorization, authorization, denial, and dispute resolution in accordance with R.S. 23:1203.1.

#### B. Statutory Provisions

##### 1. Emergency Care

a. In addition to all other utilization review rules and procedures, R.S. 23:1142 provides that no prior consent by the carrier/self-insured employer is required for any emergency medical procedure or treatment deemed immediately necessary by the treating health care provider. Any health care provider who authorizes or orders diagnostic testing or treatment subsequently held not to have been of an emergency nature shall be responsible for all of the charges incurred in such testing or treatment. Such health care provider shall bear the burden of proving the emergency nature of the diagnostic testing or treatment.

b. Fees for those services of the health care provider held not to have been of an emergency nature shall not be an enforceable obligation against the employee or the employer or the employer's workers' compensation insurer unless the employee and the payor have agreed upon the treatment or diagnostic testing by the health care provider.

2. Non-Emergency Care. In addition to all other utilization review rules and procedures, the law (R.S. 23:1142) establishes a monetary limit for non-emergency medical care. No health care provider shall incur more than a total of \$750 in non-emergency diagnostic testing or treatment without the mutual consent of the carrier/self-insured employer and the employee. The statute further provides significant penalties for a carrier's/self-insured employer's arbitrary and capricious refusal to approve necessary care beyond that limit.

##### 3. Medical Treatment Schedule

a. In addition to all other utilization review rules and procedures, R.S. 23:1203.1 provides that after the promulgation of the medical treatment schedule, medical care, services, and treatment due, pursuant to R.S. 23:1203 et seq., by the employer to the employee shall mean care, services, and treatment in accordance with the medical treatment schedule.

b. Pursuant to R.S. 23:1203.1(I), medical care, services, and treatment that varies from the promulgated medical treatment schedule shall also be due by the employer when it is demonstrated to the medical director of the Office of Workers' Compensation by a preponderance of

the scientific medical evidence, that a variance from the medical treatment schedule is reasonably required to cure or relieve the injured worker from the effects of the injury or occupational disease given the circumstances.

c. Pursuant to R.S. 23:1203.1(M), with regard to all treatment not covered by the medical treatment schedule, all medical care, services, and treatment shall be in accordance with Subsection D of R.S. 23:1203.1.

d. Except as provided pursuant to D.2, all requests for authorization of care beyond the statutory non-emergency monetary limit of \$750 are to be presented to the carrier/self-insured employer. In accordance with these Utilization Review Rules, the carrier/self-insured employer or a utilization review company acting on its behalf shall determine if such request is in accordance with the medical treatment schedule. If the request is denied or approved with modification and the health care provider determines to request a variance from the medical director, then a LWC-WC-1009 shall be filed as provided in Subsection G of this Section.

e. Disputes shall be filed by any aggrieved party on a LWC-WC-1009 within 15 calendar days of receipt of the denial or approval with modification of a request for authorization. The medical director shall render a decision as soon as practicable, but in no event later than 30 calendar days from the date of filing. The decision shall determine whether:

i. the recommended care, services, or treatment is in accordance with the medical treatment schedule; or

ii. a variance from the medical treatment schedule is reasonably required; or

iii. the recommended care, services, or treatment that is not covered by the medical treatment schedule is in accordance with another state's adopted guideline pursuant to Subsection D of R.S. 23:1203.1.

f. In accordance with LAC 40:I.5507.C, any party feeling aggrieved by the R.S. 23:1203.1(J) determination of the medical director shall seek a judicial review by filing a Form LWC-WC-1008 in a workers' compensation district office within 15 calendar days of the date said determination is mailed to the parties. A party filing such appeal must simultaneously notify the other party that an appeal of the medical director's decision has been filed. Upon receipt of the appeal, the workers' compensation judge shall immediately set the matter for an expedited hearing to be held not less than 15 days nor more than 30 calendar days after the receipt of the appeal by the office. The workers' compensation judge shall provide notice of the hearing date to the parties at the same time and in the same manner.

g. R.S. 23:1203.1(J) provides that after a health care provider has submitted to the carrier/self-insured employer the request for authorization and the information required pursuant to this Section, the carrier/self-insured employer shall notify the health care provider of their action on the request within five business days of receipt of the request.

#### C. Minimum Information for Request of Authorization

## LABOR AND EMPLOYMENT

1. Initial Request for Authorization. The following criteria are the minimum submission by a health care provider requesting care beyond the statutory non-emergency medical care monetary limit of \$750 and will accompany the LWC-WC-1010:

- a. history provided to the level of the condition and as provided in the medical treatment schedule;
- b. physical findings/clinical tests;
- c. documented functional improvements from prior treatment, if applicable;
- d. test/imaging results; and
- e. treatment plan including services being requested along with the frequency and duration.

2. To make certain that the request for authorization meets the requirements of this Subsection, the health care provider should review the medical treatment schedule for each area(s) of the body to obtain specific detailed information related to the specific services or diagnostic testing that is included in the request. Each section of the medical treatment schedule contains specific recommendations for clinical evaluation, treatment and imaging/testing requirements. The medical treatment guidelines can be viewed on Louisiana's Workforce Commission website. The specific URL is [http://www.laworks.net/WorkersComp/OWC\\_MedicalGuideLines.asp](http://www.laworks.net/WorkersComp/OWC_MedicalGuideLines.asp).

3. Subsequent Request for Authorizations. After the initial request for authorization, subsequent requests for additional diagnostic testing or treatment does not require that the healthcare provider meet all of the initial minimum requirements listed above. Subsequent requests require only updates to the information of Subparagraph 1.a-e above. However such updates must demonstrate the patient's current status to document the need for diagnostic testing or additional treatment. A brief history, changes in clinical findings such as orthopedic and neurological tests, and measurements of function with emphasis on the current, specific physical limitations will be important when seeking approval of future care. The general principles of the medical treatment schedule are:

- a. the determination of the need to continue treatment is based on functional improvement; and
- b. the patient's ability (current capacity) to return to work is needed to assist in disability management.

### D. Submission and Process for Request for Authorization

1. Except as provided pursuant to D.2., to initiate the request for authorization of care beyond the statutory non-emergency medical care monetary limit of \$750 per health care provider, the health care provider shall submit LWC-WC-1010 along with the required information of this Section by fax or email to the carrier/self insured employer.

#### 2. Evaluation and Management Visits

a. The medical treatment schedule provides that a timely routine evaluation and management office visit with the treating physician is required for documentation of

functional improvement resulting from previously authorized medical care, service and treatment. A LWC-WC-1010 shall be required to initiate the request for authorization of the first routine evaluation and management office visit that occurs beyond the statutory non-emergency medical care monetary limit of \$750 per health care provider. If such routine evaluation and management office visit is approved as medically necessary, a LWC-WC-1010 shall not be required for any subsequent routine evaluation and management office visits with the employee's treating physician within the first year of the accident date not to exceed 12 visits. Any routine evaluation and management office visit that occurred prior to the first submission of a LWC-WC-1010 shall count towards the 12 visits to occur within one year of the accident date. A LWC-WC-1010 shall be required for a routine evaluation and management office visit after the twelfth visit or after one year from date of accident. If approved, an LWC-WC-1010 shall only be required on every fourth routine evaluation and management office visit thereafter. The carrier/self-insured employer may authorize more office visits over a defined period of time.

b. A routine evaluation and management office visit is limited to new and established patient evaluation and management office/outpatient visits, which includes the following Current Procedural Terminology Codes: 99201, 99202, 99203, 99204, 99205, 99211, 99212, 99213, 99214, and 99215.

c. Any medical care, services, or treatment performed at such routine evaluation and management office visit that will be billed as anything other than a routine evaluation and management office visit code shall require pre approval with a request for authorization on a form LWC-WC-1010. Nothing contained in Subparagraph D.2.a of this Section shall prevent the carrier/self insured employer from denying one of the 12 routine evaluation and management office visits to occur within the first year of the accident date for reasons other than medical necessity to include but not be limited to causation, compensability, and medical relatedness. After the first 12 routine evaluation and management office visits or after one year from the date of accident, the carrier/self insured employer may deny as not medically necessary any request for a routine evaluation and management office visit.

### 3. Authorization for Active Therapeutic Exercise

a. If the carrier/self insured employer determines on an otherwise compensable claim that modifications to a request for authorization on LWC-WC-1010 for active therapeutic exercise is necessary in order for the request for authorization to be in accordance with the medical treatment schedule, said request shall not be approved with modification for a number of treatments less than the minimum "time to produce effect" found in the applicable portion of the medical treatment schedule.

b. Notwithstanding the provisions of Subparagraph 3.a., the carrier/self-insured employer may approve with modification a request for active therapeutic exercise below the minimum "time to produce effect" found in the applicable portion of the medical treatment schedule if the carrier/self-insured employer has already approved active

therapeutic exercise beyond the “frequency” and “maximum duration” found in the applicable portion of the medical treatment schedule.

4. The carrier/self-insured employer shall provide to the OWC a fax number and/or email address to be used for purposes of these rules and particularly for LWC-WC-1010 and 1010A. If the fax number and/or email address provided is for a utilization review company contracted with the carrier/self-insured employer, then the carrier/self-insured employer shall provide the name of the utilization review company to the OWC. All carrier/self-insured employer fax numbers and/or email addresses provided to the OWC will be posted on the office’s website at [www.laworks.net](http://www.laworks.net). If the fax number or e-mail address is for a contracted utilization review company, then the OWC will also post on the web the name of the utilization review company. When requesting authorization and sending the LWC-WC-1010 and 1010A, the health care provider shall use the fax number and/or email address found on the OWC website.

5. Pursuant to R.S. 23:1203.1, the five business days to act on the request for authorization does not begin for the carrier/self-insured employer until the information of Subsection C and LWC-WC-1010 is received. In the absence of the submission of such information, any denial of further non-emergency care by the carrier/self-insured employer is prima facie, not arbitrary and capricious.

#### E. First Request

1. If a carrier/self-insured employer determines that the information required in Subsection C of this Section has not been provided, then the carrier/self-insured employer shall, within five business days of receipt of LWC-WC-1010, notify the health care provider of its determination. Notice shall be by fax or e-mail to the healthcare provider and shall include the provider-submitted LWC-WC-1010 with the “first request” section completed to indicate a delay due to lack of information and LWC-WC-1010A identifying the information that was not provided. A copy of the LWC-WC-1010 and all information faxed or emailed to the health care provider shall also be faxed or emailed to the claimant attorney, if any. On the same business day, a copy of the LWC-WC-1010 and all information faxed or emailed to the health care provider shall also be sent by regular mail to the claimant’s last known address.

a. The health care provider must respond by fax or e-mail to the carrier/self-insured employer’s request for additional information within 10 business days of receipt of the request.

b. If the health care provider agrees that the additional information from the first request is due, then such information shall be provided along with LWC-WC-1010 and 1010A.

c. If the health care provider disagrees that the additional information in the first request is due, then the health care provider shall return the LWC-WC-1010 and 1010A with an explanation describing why the health care provider believes all required information has been previously provided.

d. If the health care provider fails to respond to the first request within 10 business days of receipt, then such failure to respond shall result in a withdrawal of the request for authorization without further action by the OWC or the carrier/self-insured employer. In order to obtain authorization for care the health care provider will be required to initiate a new request for authorization with a new LWC-WC-1010 pursuant to this Section.

e. The carrier/self-insured employer must respond by fax or e-mail within five business days of receipt of a timely submitted response from the health care provider:

i. if the health care provider responds timely with additional information and the carrier/self-insured employer determines that the requested information has been provided, then the carrier/self-insured employer has five business days to act on the request for authorization pursuant to R.S. 23:1203.1(J) and these rules. Subsection G of this Section provides the rules regarding whether a request for authorization is approved, approved with modification, or denied;

ii. if the health care provider responds timely with additional information but the carrier/self-insured employer determines that the requested information has again not been provided, then the carrier/self-insured employer shall return LWC-WC-1010 to the health care provider, and indicate suspension of prior authorization process due to lack of information;

iii. if the health care provider responds timely with the appropriate forms and an explanation as to why no additional information is necessary; and

iv. the carrier/self-insured employer determines that the request for information has been satisfied, then the carrier/self-insured employer has five business days to act on the request for authorization pursuant to R.S. 23:1203.1(J) and these rules. Subsection G of this Section provides the rules regarding whether a request for authorization is approved, approved with modification, or denied;

v. the carrier/self-insured employer determines that the requested information has still not been provided, then the carrier/self-insured employer shall return to the health care provider the LWC-WC-1010 indicating suspension of prior authorization process due to lack of information.

2.a. A carrier/self-insured employer who fails to return LWC-WC-1010 within the five business days as provided in this Subsection is deemed to have denied such request for authorization. A health care provider, claimant, or claimant’s attorney if represented who chooses to appeal a denial pursuant to this Subsection shall file a LWC-WC-1009 pursuant to Subsection J of this Section.

b. A request for authorization that is deemed denied pursuant to this Subparagraph may be approved by the carrier/self-insured employer within 10 calendar days of being deemed denied. The approval will be indicated in section 3 of LWC-WC-1010. The medical director shall dismiss any appeal that may have been filed by a LWC-WC-1009. The carrier/self-insured employer shall be given a

## LABOR AND EMPLOYMENT

presumption of good faith regarding the decision to change the denial to an approval provided that the LWC-WC-1010 which indicates "approved" in section 3 is faxed or emailed within the 10 calendar days.

### F. Appeal of Suspension of Prior Authorization Process

1. If the health care provider disagrees with the suspension of prior authorization process, the provider, within five business days of receipt of the suspension, shall file an appeal with the medical services section of the OWC. The appeal shall include:

a. a copy of the LWC-WC-1010 submitted to the carrier/self-insured employer. The health care provider should complete the appropriate section of the form indicating that an appeal is being requested; and

b. a copy of LWC-WC-1010A; and

c. a copy of all information previously submitted to the carrier/self-insured employer.

2. The medical services section shall, within 10 business days of receipt of the filed LWC-WC-1010:

a. determine whether the information provided satisfied the provisions of Subsection C of this Section; and

b. issue a written determination to the health care provider, claimant and carrier/self-insured employer.

3. If the medical services section determines that the requested information was not provided, then the health care provider will be required to submit the information to the carrier/self-insured employer within five business days of receipt of the decision of the medical services section.

a. If the information is provided as required by decision of the medical services section, the carrier/self-insured employer shall have five business days to act on the request for authorization pursuant to R.S. 23:1203.1(J) and these rules. Subsection G of this Section provides the rules regarding a request for authorization being approved, approved with modification, or denied.

b. Failure of the health care provider to provide the information within five business days of receipt of the decision of the medical services section shall result in a withdrawal of the request for authorization without further action by the OWC or the carrier/self-insured employer. In order to obtain authorization, the medical provider will be required to initiate a new request for authorization pursuant to this Section.

4. If the medical services section determines that the requested information was provided, then within five business days of receipt of the decision of the medical services section decision, the carrier/self-insured employer shall act on the request for authorization pursuant to R.S. 23:1203.1(J) and these rules with the information as previously provided. Subsection G of this Section provides the rules regarding a request for authorization being approved, approved with modification, or denied.

5. Failure of the carrier/self-insured employer to act on the request within the five business days will be deemed a denial of the request for authorization. A health care

provider, claimant, or claimant's attorney if represented who chooses to appeal a denial pursuant to this subparagraph shall file a LWC-WC-1009 pursuant to Subsection J of this Section.

6. A request for authorization that is deemed denied pursuant to this subparagraph may be approved by the carrier/self-insured employer within 10 calendar days of being deemed denied. The approval will be indicated in section 3 of LWC-WC-1010. The medical director shall dismiss any appeal that may have been filed by a LWC-WC-1009. The carrier/self-insured employer shall be given a presumption of good faith regarding the decision to change the denial to an approval provided that the LWC-WC-1010 which indicates "approved" in section 3 is faxed or emailed within the 10 calendar days.

### G. Approval or Denial of Authorization for Care

1. Request for authorization covered by the medical treatment schedule. Upon receipt of the LWC-WC-1010 and the required medical information in accordance with this Section, the carrier/self-insured employer shall have five business days to notify the health care provider of the carrier/self-insured employer's action on the request. Based upon the medical information provided pursuant to this Section the carrier/self-insured employer will determine whether the request for authorization is in accordance with the medical treatment schedule:

a. the carrier/self-insured employer will return to the health care provider Form 1010, and indicate in the appropriate section on the form that "The requested treatment or testing is approved" if the request is in accordance with the medical treatment schedule; or

b. the carrier/self-insured employer will return to the health care provider, claimant, and the claimant's attorney if one exists, the LWC-WC-1010, and indicate in the appropriate section on the form "The requested treatment or testing is approved with modification" if the carrier/self-insured employer determines that modifications are necessary in order for the request for authorization to be in accordance with the medical treatment schedule, or that a portion of the request for authorization is denied because it is not in accordance with the medical treatment schedule. The carrier/self-insured employer shall include with the LWC-WC-1010 a summary of reasons why a part of the request for authorization is not in accordance with the medical treatment schedule and explain any modification to the request for authorization. The LWC-WC-1010 and the summary of reasons shall be faxed or emailed to the health care provider and to the claimant attorney, if any. On the same business day, a copy of the LWC-WC-1010 and the summary of reasons shall also be sent by regular mail to the claimant's last known address; or

c. the carrier/self-insured employer will return to the health care provider, the claimant, and the claimant's attorney if one exists, the LWC-WC-1010, and indicate in the appropriate section on the form "the requested treatment or testing is denied" if the carrier/self-insured employer determines that the request for authorization is not in accordance with the medical treatment schedule. The carrier/self-insured employer shall include with the LWC-



WC-1010 a summary of reasons why the request for authorization is not in accordance with the medical treatment schedule. The LWC-WC-1010 and the summary of reasons shall be faxed or mailed to the health care provider and to the claimant attorney, if any. On the same business day, a copy of the LWC-WC-1010 and the summary of reasons shall also be sent by regular mail to the claimant's last known address.

2. Request for Authorization not Covered by the Medical Treatment Schedule. Requests for authorization of medical care, services, and treatment that are not covered by the medical treatment schedule in accordance to R.S. 23:1203.1(M), must follow the same prior authorization process established for all other requests for medical care, services, and treatment. A request for authorization that is not covered by the medical treatment schedule exists when the requested care, services, or treatment are for a diagnosis not addressed by the medical treatment schedule. The health care Provider requesting care, services, or treatment that is not covered by the medical treatment schedule may submit documentation sufficient to establish that the request is in accordance with R.S. 23:1203.1(D). After timely receipt of the LWC-WC-1010, the submitted documentation if any, and the required medical information in accordance with this Section, the carrier/self-insured employer shall determine whether the request for authorization is in accordance with R.S. 23:1203.1(D). In making this determination, the carrier/self-insured employer shall review the submitted documentation, but may apply another guideline that meets the criteria of R.S. 23:1203.1(D). The carrier/self-insured employer has five business days to notify the health care provider of the carrier/self-insured employer's action on the request:

a. the carrier/self-insured employer will return to the health care provider the LWC-WC-1010, and indicate in the appropriate section on the form that "The requested treatment or testing is approved" if the request is in accordance with R.S. 23:1203.1(D); or

b. the carrier/self-insured employer will return to the health care provider, claimant, and the claimant's attorney if one exists, the LWC-WC-1010, and indicate in the appropriate section on the form "The requested treatment or testing is approved with modification" if the carrier/self-insured employer determines that modifications are necessary in order for the request for authorization to be in accordance with R.S. 23:1203.1(D), or that a portion of the request for authorization is denied because it is not in accordance with R.S.23:1203.1(D). The carrier/self insured employer shall include with the LWC-WC-1010 a summary of reasons why a part of the request for authorization is not in accordance with R.S. 23:1203.1(D). The LWC-WC-1010 and the summary of reasons shall be faxed or emailed to the health care provider and to the claimant attorney, if any. On the same business day a copy of the LWC-WC-1010 and the summary of reasons shall also be sent by regular mail to the claimant's last known address; or

c. the carrier/self-insured employer will return to the health care provider, the claimant, and the claimant's attorney if one exists, the LWC-WC-1010, and indicate in

the appropriate section on the form "the requested treatment or testing is denied" if the carrier/self-insured employer determines that the request for authorization is not in accordance with R.S. 23:1203.1(D). The carrier/self-insured employer shall include with the LWC-WC-1010 a summary of reasons why the request for authorization is not in accordance with R.S. 23:1203.1(D). The LWC-WC-1010 and the summary of reasons shall be faxed or emailed to the health care provider and to the claimant attorney, if any. On the same business day a copy of the LWC-WC-1010 and the summary of reasons shall also be sent by regular mail to the claimant's last known address.

3. Summary of Reasons. The summary of reasons provided by the carrier/self-insured employer with the approval with modification or denial shall include:

- i. the name of the employee;
- ii. the date of accident;
- iii. the name of the health care provider requesting authorization;
- iv. the decision (approved with modification, denied);
- v. the clinical rationale to include a brief summary of the medical information reviewed;
- vi. the criteria applied to include specific references to the medical treatment schedule, or to the guidelines adopted in another state if the requested care, services or treatment is not covered by the medical treatment schedule; and
- vii. a Section labeled "Voluntary Reconsideration" pursuant to Paragraph I.2 of this Section that includes a phone number that will allow the health care provider to speak to a person with the carrier/self-insured employer or its utilization review company with authority to reconsider a denial or approval with modification.

4. Upon receipt of the LWC-WC-1010 and the required medical information in accordance with this Section, the carrier/self-insured employer shall have five business days to notify the health care provider of the carrier/self-insured employer's action on the request. Based upon the medical information provided pursuant to this Section, and other information known to the carrier/self-insured employer at the time of the request for authorization, the carrier will return to the health care provider, claimant, and claimant's attorney if one exists, the LWC-WC-1010 and indicate in the appropriate section on the form "the requested treatment or testing is denied because:

- a. "the request for authorization or a portion thereof is not related to the on-the-job injury;" or
- b. "the claim is non-compensable;" or
- c. "other" and provide a brief explanation for the basis of denial.

5. The LWC-WC-1010 and the summary of reasons shall be faxed or emailed to the health care provider and the claimant attorney, if any. On the same business day a copy of

## LABOR AND EMPLOYMENT

the LWC-WC-1010 and the summary of reasons shall also be sent by regular mail to the claimant's last known address.

H. Failure to respond by carrier/self-insured employer. A carrier/self-insured employer who fails to return LWC-WC-1010 with section 3 completed within the five business days to act on a request for authorization as provided in this Section is deemed to have denied such request for authorization. A health care provider, claimant, or claimant's attorney if represented who chooses to appeal a denial pursuant to this Subparagraph shall file a LWC-WC-1009 pursuant to Subsection J of this Section.

### I. Reconsideration Prior to LWC-WC-1009 Decision

1. R.S. 23:1203.1(L) provides that it is the intent of the legislature that, with establishment of the medical treatment schedule, medical and surgical treatment, hospital care, and other health care provider services shall be delivered in an efficient and timely manner to injured employees.

2. In furtherance of that goal, the LWC-WC-1010 and the summary of reasons provided by the carrier/self-insured employer with the denial or approved with modification will include a statement that the health care provider is encouraged to contact the carrier/self-insured employer to discuss reconsideration of the denial or approval with modification. The carrier/self-insured employer shall include on the summary of reasons a section labeled "voluntary reconsideration," and include a phone number that will allow the health care provider to speak to a person with the carrier/self-insured employer or its utilization review company with authority to reconsider the previous denial or approval with modification.

3. Reconsideration after denied or approved with modification. If the carrier/self-insured employer determines that the requested care should now be approved, it will return to the health care provider, the claimant, and the claimant's attorney if one exists within 10 calendar days of the denial or approval with modification, the LWC-WC-1010, and in the appropriate section on the form indicate "the prior denied or approved with modification request is now approved." Such approval ends the utilization review process as it relates to the request. A LWC-WC-1009 or 1008 shall not be filed regarding such request. The carrier/self-insured employer shall be given a presumption of good faith regarding the decision to change its decision of denied or approved with modification to approved after discussing the request with the health care provider.

4. Reconsideration after deemed denied due to failure to respond. A request for authorization that is deemed denied pursuant to Subsection H of this Section may be approved by the carrier/self-insured employer within 10 calendar days of the request for authorization as indicated on the LWC-WC-1010. The approval will be indicated in Section 3 of LWC-WC-1010. The medical director shall dismiss any appeal that may have been filed by a LWC-WC-1009. The carrier/self-insured employer shall be given a presumption of good faith regarding the decision to change the denial to an approval provided that the LWC-WC-1010 which indicates "approved" in Section 3 is faxed or emailed within 10 calendar days of the request for authorization.

J. Review of denial, approved with modification, deemed denied, or variance by LWC-WC-1009.

1. Any aggrieved party who disagrees with a request for authorization that is denied, approved with modification, deemed denied pursuant to Paragraphs E.2, F.5, and Subsection H, or who seeks a determination from the medical director with respect to medical care, services, and treatment that varies from the medical treatment schedule shall file a request for review with the OWC. The request for review shall be filed within 15 calendar days of:

a. receipt of the LWC-WC-1010 by the health care provider indicating that care has been denied or approved with modification; or

b. the expiration of the fifth business day without response by the carrier/self-insured employer pursuant to Paragraphs E.2, F.5, and Subsection H of this Section.

2. The request for review shall include:

a. LWC-WC-1009 which shall state the reason for review is either;

i. a request for authorization that is denied; or

ii. a request for authorization that is approved with modification; or

iii. a request for authorization that is deemed denied pursuant to Paragraphs, E.2, F.5, and Subsection H; or

iv. a variance from the medical treatment schedule is warranted; and

b. a copy of LWC-WC-1010 which shows the history of communications between the health care provider and the carrier/self-insured employer that finally resulted in the request being denied or approved with modification; and

c. all of the information previously submitted to the carrier/self-insured employer; and

d. in cases where a variance has been requested, the health care provider or claimant shall also provide any other evidence supporting the position of the health care provider or the claimant including scientific medical evidence demonstrating that a variance from the medical treatment schedule is reasonably required to cure or relieve the claimant from the effects of the injury or occupational disease given the circumstances.

3. In cases where the requested care, services, or treatment are not covered by the medical treatment schedule pursuant to R.S. 23:1203.1(M):

i. the health care provider may also submit with the LWC-WC-1009 the documentation provided to the carrier/self-insured employer pursuant to Paragraph G.2 of this Section; and

ii. the carrier/self-insured employer may submit to the medical director within five business days of receipt of the LWC-WC-1009 from the health care provider or claimant the documentation used to deny or approve with modification the request for authorization pursuant to R.S. 23:1203.1(D). A copy of the information being submitted to

the medical director must be provided by fax or email to the health care provider and claimant attorney, if any, and on the same business day to the claimant by regular mail at his last known address.

4. The health care provider or claimant filing the LWC-WC-1009 shall certify that such form and all supporting documentation has been sent to the carrier/self-insured employer by email or fax. The OWC shall notify all parties of receipt of a LWC-WC-1009.

5.a. Within five business days of receipt of the LWC-WC-1009 from the health care provider or claimant, the carrier/self-insured employer shall provide to the medical director, with a copy going to the health care provider or claimant attorney, if any, via fax or email and on the same business day to the claimant via regular mail at his last known address, any evidence it thinks pertinent to the decision regarding the request being denied, approved with modification, deemed denied, or that a variance from the medical treatment schedule is warranted.

b. The medical director shall within 30 calendar days of receipt of the LWC-WC-1009, and consideration of any medical evidence from the carrier/self-insured employer if provided within such five business days, render a decision as to whether the request for authorization is medically necessary and is:

i. in accordance with the medical treatment schedule; or

ii. in accordance with R.S. 23:1203.1(D) if such request is not covered by the medical treatment schedule, or

iii. whether the health care provider or claimant demonstrates by a preponderance of the scientific medical evidence that a variance from the medical treatment schedule is reasonably required. The decision of the medical director shall be provided in writing to the health care provider, claimant, claimant's attorney if one exists, and Carrier/Self-Insured Employer.

c. The decision of the medical director shall include:

i. the date the decision is mailed; and

ii. the name of the employee; and

iii. the date of accident; and

iv. the decision of the medical director; and

v. the clinical rationale to include a summary of the medical information reviewed; and

vi. the criteria applied to make the LWC-WC-1009 decision.

#### K. Appeal of 1009 Decision by Filing 1008

1. In accordance with LAC 40:I.5507.C, any party feeling aggrieved by the R.S. 23:1203.1(J) determination of the medical director shall seek a judicial review by filing a Form LWC-WC-1008 in a workers' compensation district office within 15 calendar days of the date said determination is mailed to the parties. The filed LWC-WC-1008 shall include a copy of the LWC-WC-1009 and the decision of the

medical director. A party filing such appeal must simultaneously notify the other party that an appeal of the medical director's decision has been filed. Upon receipt of the appeal, the workers' compensation judge shall immediately set the matter for an expedited hearing to be held not less than 15 calendar days nor more than 30 calendar days after the receipt of the appeal by the office. The workers' compensation judge shall provide notice of the hearing date to the parties at the same time and in the same manner. The decision of the medical director may only be overturned when it is shown, by clear and convincing evidence that the decision was not in accordance with the provisions of R.S. 23:1203.1.

#### L. Variance to Medical Treatment Schedule

1. Requests for authorization of medical care, services, and treatment that may vary from the medical treatment schedule must follow the same prior authorization process established for all other requests for medical care, services, and treatment that require prior authorization. If a request is denied or approved with modification, and the health care provider or claimant determines to seek a variance from the medical director, then a LWC-WC-1009 shall be filed as provided in Subsection J of this Section. The health care provider, claimant, or claimant's attorney filing the LWC-WC-1009 shall submit with such form the scientific medical literature that is higher ranking and more current than the scientific medical literature contained in the medical treatment schedule, and which supports approval of the variance.

2. A variance exists in the following situations.

a. The requested care, services, or treatment is not recommended by the medical treatment schedule although the diagnosis is covered by the medical treatment schedule.

b. The requested care, services, or treatment is recommended by the medical treatment schedule, but for a different diagnosis or body part.

c. The requested care, services, or treatment involves a medical condition of the claimant that complicates recovery of the claimant that is not addressed by the medical treatment schedule.

M. Emergency Care. In addition to all other rules and procedures, the health care provider who provides care under the "medical emergency" exception must demonstrate that it was a "medical emergency" in the following manner:

a. by demonstrating that the illness or condition presents one or more of the following findings:

i. Severity of Illness Criteria:

(a). Sudden Onset of Unconsciousness or Disorientation (coma or unresponsiveness);

(b). Pulse Rate:

(i). less than 50 per minute;

(ii). greater than 140 per minute;

(c). Blood Pressure:

## LABOR AND EMPLOYMENT

(i). systolic less than 90 or greater than 200 mm Hg.;

(ii). diastolic less than 60 or greater than 120 mm Hg.;

(d). acute loss of sight or hearing;

(e). acute loss of ability to move body part;

(f). persistent fever equal to or greater than 100 (p.o.) or greater than 101(r) for more than five days;

(g). active bleeding;

(h). severe electrolyte/blood gas abnormality (any of the following):

(i).  $\text{Na} < 124 \text{ mEq/L}$ , or  $\text{Na} > 156 \text{ mEq/L}$ ;

(ii).  $\text{K} < 2.5 \text{ mEq/L}$ , or  $\text{K} > 6.0 \text{ mEq/L}$ ;

(iii).  $\text{CO}_2$  combining power [unless chronically abnormal]  $< 20 \text{ mEq/L}$ , or  $\text{CO}_2$  combining power [unless chronically abnormal]  $> 36 \text{ mEq/L}$ ;

(iv). blood ph  $< 7.30$ , or blood ph  $> 7.45$ ;

(i). acute or progressive sensory, motor, circulatory or respiratory embarrassment sufficient to incapacitate the patient (inability to move, feed, breathe, etc.).

NOTE: Must also meet Intensity of Service criterion simultaneously in order to certify. Do not use for back pain.

(j). EKG evidence of acute ischemia; must be suspicion of a new MI;

(k). wound dehiscence or evisceration.

### ii. Intensity of Service Criteria

(a). Intravenous medications and/or fluid replacement (does not include tube feedings);

(b). surgery or procedure scheduled within 24 hours requiring:

(i). general or regional anesthesia; or

(ii). use of equipment, facilities, procedure available only in a hospital;

(c). vital sign monitoring every two hours or more often (may include telemetry or bedside cardiac monitor);

(d). chemotherapeutic agents that require continuous observation for life threatening toxic reaction;

(e). treatment in an I.C.U.;

(f). intramuscular antibiotics at least every eight hours;

(g). intermittent or continuous respirator use at least every eight hours;

NOTE: If at least one criterion is satisfied from both the severity of illness criteria and the intensity of service criteria, the service is considered to be emergency.

b. by demonstrating by other objective criteria that the treatment was necessary to prevent death, or serious permanent impairment to the patient.

### N. Change of Physician

1. Requests for change of treating physician within one field or specialty shall be made in writing to the carrier/self-insured employer and shall contain a clear statement of the reason for the requested change. Having exhausted the monetary limit for non-emergency treatment is insufficient justification, without other reasons. The carrier/self-insured employer shall notify all parties of the request, and of their action on the request, within five calendar days of date of receipt of the request. Failure to timely respond may result in assessment of penalties by the hearing officer.

2. Disputes over change of physician will be resolved in accordance with R.S. 23:1121.

O. Opposing Medical Opinions. In the event that there are opposing medical opinions regarding claimant's condition or capacity to work, the Office of Workers' Compensation Administration will appoint an independent medical examiner of the appropriate licensure class to examine the claimant, or review the medical records at issue. The expense of this examination will be set by the director and will be borne by the carrier/self-insured employer.

AUTHORITY NOTE: Promulgated in accordance with R.S. 23:1203.1.

HISTORICAL NOTE: Promulgated by the Department of Employment and Training, Office of Workers' Compensation, LR 17:263 (March 1991), repromulgated LR 17:653 (July 1991), repromulgated LR 18:257 (March 1992), amended by the Louisiana Workforce Commission, Office of Workers' Compensation, LR 38:1030 (April 2012), repromulgated LR 38:1287 (May 2012), amended LR 38:3255 (December 2012), LR 40:1163 (June 2014).

### §2717. Medical Review Guidelines

A. Workers' Compensation is designed to provide indemnity and medical care benefits for workers who sustain injuries or illnesses arising out of and in the course and scope of employment. The following instructions give some general guidelines for medical review of workers' compensation claims.

#### B. Technical Considerations for Review of Claims

1. Prior to a detailed medical review, a cursory review of the claim should be accomplished and should include at least the following.

a. Job related illness/injury must be identified.

b. Each service/item billed must be identifiable.

c. Billing period must be identified.

d. Appropriate forms must be used and filled out completely.

2. If the cursory review indicates that sufficient information is present, processing of the claim can proceed. If the review indicates information is lacking, the carrier/self-insured employer must take immediate and appropriate action to obtain the information required. The "timely payment" provision contained in the statement of

policy in this manual will not apply until the required information is obtained. However, absence of nonessential information is not justification for delay in claim processing.

C. Functions of Medical Review. The carrier/self-insured employer should use a program of prevention and detection to guarantee the most appropriate and economical use of health care resources for claimants.

1. Prevention through Education. Informing physicians and other health care providers about workers' compensation programs, policies and statutory provisions that deal with claim submission is the key to ensuring the appropriate billing of covered services. As part of that educational focus, the following are some of the administrative policies encountered in the review process:

- a. quality of care;
- b. medical necessity;
- c. screening tests;
- d. confidentiality;
- e. general documentation requirements.

2. Quality of Care. Quality care should:

a. be provided in a timely manner, without inappropriate delay, interruption, premature termination or prolongation of treatment, and emphasize an early, safe return to work;

b. seek the patient's cooperation and participation in the decisions and process of his or her treatment;

c. be based on accepted principles of evidence based practice as established in R.S. 23:1203.1 and the skillful and appropriate use of other health professionals and technology;

d. be provided with sensitivity to the stress and anxiety that illness can cause, and with concern for the patient's and family's overall welfare and should focus on improvement in function related to the physical demands of the injured workers' job;

e. use technology and other resources efficiently to achieve the treatment goal;

f. be sufficiently documented in the patient's medical record to allow continuity of care and peer evaluation.

3. Medical Necessity

a. The workers' compensation law provides benefits only for services that are medically necessary for the diagnosis or treatment of a claimant's work related illness, injury, symptom or complaint. *Medically necessary* or *medical necessity* shall mean health care services that are:

i. clinically appropriate, in terms of type, frequency, extent, site, and duration, and effective for the patient's illness, injury, or disease; and

ii. in accordance with the medical treatment schedule and the provisions of R.S. 23:1203.1.

b. To be medically necessary, a service must be:

i. consistent with the diagnosis and treatment of a condition or complaint; and

ii. in accordance with the Louisiana medical treatment schedule; and

iii. not solely for the convenience of the patient, family, hospital or physician; and

iv. furnished in the most appropriate and least intensive type of medical care setting required by the patient's condition.

c. Services not related to the diagnosis or treatment of a work related illness or injury are not payable under the workers' compensation laws and shall be the financial responsibility of the claimant, and in appropriate cases, his health insurance carrier.

4. Screening Tests

a. A screening test not related to the on-the-job illness or injury is not covered under the workers' compensation law.

b. A screening test may be defined as a diagnostic procedure or test which is performed for a claimant in the absence of, or regardless of, his/her presenting sign(s), complaint(s), or symptom(s).

c. Although screening tests may reflect good medical practice, such tests are not covered under the Workers' Compensation Program if not specifically related to the on-the-job illness or injury. For example, a standard battery of laboratory tests ordered without regard to a specific symptom or diagnosis consistent with the reported on-the-job illness or injury, is considered nonpayable screening.

d. Payment for such test(s) shall be an enforceable obligation against the claimant and, in appropriate cases, his health insurance carrier, but shall not be an enforceable obligation against the employer or insurer.

5. Confidentiality. When it is necessary to request additional information to clarify the need for services or substantiate coverage for a claim being reviewed, the carrier/self-insured employer must take particular care to ensure that all of its employees adhere to strict policy guidelines regarding claimant privacy. The carrier/self-insured employer shall require only sufficient information to allow a reviewer to make an independent judgement regarding diagnosis and treatment. Intimate details in a claimant's records are neither necessary nor desired, and are specifically protected by law.

6. General Documentation Requirements. The determination of appropriate reimbursement requires adequate documentation of services. The following items establish the minimum documentation requirements prior to payment.

a. Documentation for all services must be legible and signed by the health care provider, i.e., date(s) of service, type of surgery where applicable, diagnosis (not a list of symptoms).

## LABOR AND EMPLOYMENT

b. Submitted documentation must contain sufficient data to substantiate the diagnosis and need for treatment on each date of service.

c. To substantiate medical necessity:

i. it is essential to report the most complete and precise diagnosis(es) on the claim form;

ii. service(s) billed should be appropriate for the diagnosis;

iii. documentation in the clinical record (i.e., physical findings and historical data) should confirm the diagnosis and support the medical necessity and appropriateness of the service billed; and

iv. documentation should be available for each service billed.

d. The maintenance of adequate and accurate clinical records is a requirement for all physicians and hospitals. Documentation should be complete, including positive as well as negative findings, and should be recorded in a timely manner.

7. Detection. The carrier/self-insured employer detects the misuse of benefits through routine claims review, computer analysis, claims audit and the investigation of complaints. The carrier shall conduct such reviews and analysis on an ongoing basis and shall investigate all complaints in a timely manner. Referrals of appropriate cases may be made to the Office of Workers' Compensation Medical Review staff.

8. Prepayment and Postpayment Claim Review. A practitioner's or provider's claims may be selected for review by the Office of Workers' Compensation if utilization review procedures detect a pattern of over-utilization of services. If a review indicates a possible overuse or misuse of services, the practitioner or provider will be notified in writing that he or she will receive a request for additional information on a sampling of submitted claims.

9. Referrals. The Office of Workers' Compensation medical review staff will investigate complaints from claimants, carriers, employers, physicians, other practitioners, and health care facilities, inquiries from the press or government agencies, referrals from other internal areas of the Office of Workers' Compensation, and even

leads from various media sources (e.g., newspapers) if in the judgement of the medical manager such investigation is warranted. In appropriate cases, the Office of Workers' Compensation will refer evidence of over-utilization to the various licensing authorities.

### D. Professional Justification

1. Medical Necessity. All claims submitted for payment to the carrier/self-insured employer must be reviewed for medical necessity and for compliance with the medical treatment schedule and the provisions of R.S. 23:1201.1. Medical necessity implies the use of technologies\* services, or supplies provided by a hospital, physician, or other provider that is determined to be:

a. medically appropriate for the symptoms and diagnosis or treatment of the work-related illness or injury;

b. provided for the diagnosis or the direct care and treatment of the patient's illness or injury;

c. in accordance with the medical treatment schedule and the provisions of R.S. 23:1203.1; and

d. not primarily for the convenience of the patient, patient's family, practitioner or provider; and

e. the most appropriate level of service that can be provided to the patient.

2. Additional Medical Record Information. It is the responsibility of the claimant and provider to furnish all medical documentation needed by the carrier/self-insured employer to determine if the injury or illness is job related and if the services are medically necessary for the condition of the claimant (e.g., physician office record, hospital medical record, doctor's orders, treatment plan, vital signs, lab data, test results, nurses' notes, progress notes).

\*The term *technology* refers to any medical or surgical treatment, medical or surgical device, therapeutic or diagnostic procedure, drug, biological, or therapeutic or diagnostic agent.

AUTHORITY NOTE: Promulgated in accordance with RS 23:1291.

HISTORICAL NOTE: Promulgated by the Department of Employment and Training, Office of Workers' Compensation, LR 17:263 (March 1991), repromulgated LR 17:653 (July 1991), amended by the Louisiana Workforce Commission, Office of Workers' Compensation, LR 38:1036 (April 2012), repromulgated LR 38:1293 (May 2012).

§2718. Utilization Review Forms

A. LWC Form 1010—Request of Authorization/  
Carrier or Self Insured Employer Response

LWC FORM 1010 - REQUEST OF AUTHORIZATION/CARRIER OR SELF INSURED EMPLOYER RESPONSE			
PLEASE PRINT OR TYPE			
<b>SECTION 1. IDENTIFYING INFORMATION - To Be Filled Out By Health Care Provider</b>			
P A T I E N T	Last Name:                      First:                      Middle:		Street Address, City, State, Zip:
	Last 4 Digits of Social Security Number:	Date of Birth:	Phone Number:                      Date of Injury:
	Employers Name:		Street Address, City, State, Zip:
C A R R I E R	Name:		Adjuster:                      Claim Number (if known):
	Street Address, City, State Zip:		Email Address:                      Phone Number:                      Fax Number:
<b>SECTION 2. REQUEST FOR AUTHORIZATION - To Be Filled Out By Health Care Provider</b>			
P R O V I D E R	Requesting Health Care Provider		Phone Number:                      Fax Number:
	Street Address, City, State Zip:		Email:
	Diagnosis:		CPT/DRG Code:                      ICD/DSM Code:
	Requested Treatment or Testing (Attach Supplement If Needed):		
	Reason for Treatment or Testing (Attach Supplement If Needed):		
<b>INFORMATION REQUIRED BY RULE TO BE INCLUDED WITH REQUEST FOR AUTHORIZATION - To Be Filled Out By Health Care Provider</b> (Following is the required minimum information for Request of Authorization (LAC 40:2715 (C))			
P R O V I D E R	<input type="checkbox"/>	History provided to the level of condition and as provided by Medical Treatment Schedule	
	<input type="checkbox"/>	Physical Findings/Clinical Tests	
	<input type="checkbox"/>	Documented functional improvements from prior treatment	
	<input type="checkbox"/>	Test/imaging results	
	<input type="checkbox"/>	Treatment Plan including services being requested along with the frequency and duration	
	I hereby certify that this completed form and above required information was		<input type="checkbox"/> Faxed
		<input type="checkbox"/> Emailed	(day) (month) (year)
Signature of Health Care Provider:		Printed Name:	
<b>SECTION 3. RESPONSE OF CARRIER/SELF INSURED EMPLOYER FOR AUTHORIZATION</b> (Check appropriate box below and return to requesting Health Care Provider, Claimant and Claimant Attorney as provided by rule)			
C A R R I E R	<input type="checkbox"/> The requested Treatment or Testing is <b>approved</b>		
	<input type="checkbox"/> The requested Treatment or Testing is <b>approved with modifications</b> (Attach summary of reasons and explanation of any modifications)		
	<input type="checkbox"/> The requested Treatment or Testing is <b>denied</b> because		
	<input type="checkbox"/>	Not in accordance with Medical Treatment Schedule or R.S.23:1203.1(D) (Attach summary of reasons)	
	<input type="checkbox"/>	The request, or a portion thereof, is not related to the on-the-job injury	
	<input type="checkbox"/>	The claim is being denied as non-compensable	
<input type="checkbox"/>	Other (Attach brief explanation)		
I hereby certify that this response of Carrier/Self Insured Employer for Authorization was		<input type="checkbox"/> Faxed	to the Health Care Provider (and to the Attorney of Claimant if one exists, if denied or approved with modification) on this the _____ day of _____, _____
		<input type="checkbox"/> Emailed	(day) (month) (year)
Signature of Carrier/Self Insured Employer:		Printed Name:	

**LABOR AND EMPLOYMENT**

<b>C A R R I E R</b>	<input type="checkbox"/> The prior <b>denied</b> or <b>approved with modification</b> request is now <b>approved</b>		
	I hereby certify that this response of Carrier/Self Insured Employer for Authorization was	<input type="checkbox"/> Faxed	to the Health Care Provider and Attorney of Claimant if one exists on this the _____ day of _____, _____
		<input type="checkbox"/> Emailed	(day) (month) (year)
	<b>Signature of Carrier/Self Insured Employer:</b>		<b>Printed Name:</b>

**SECTION 4. FIRST REQUEST**  
(Form 1010A is required to be filled out by Carrier/Self Insured Employer and Health Care Provider)

<b>C A R R I E R</b>	<input type="checkbox"/> The requested Treatment or Testing is delayed because minimum information required by rule was not provided		
	I hereby certify that this First Request and accompanying Form 1010A was	<input type="checkbox"/> Faxed	to the Health Care Provider on this the _____ day of _____, _____
		<input type="checkbox"/> Emailed	(day) (month) (year)
	<b>Signature of Carrier/Self Insured Employer:</b>		

<b>P R O V I D E R</b>	I hereby certify that a response to the First Request and accompanying Form 1010A was		
		<input type="checkbox"/> Faxed	to the Carrier/Self Insured Employer on this the _____ day of _____, _____
		<input type="checkbox"/> Emailed	(day) (month) (year)
	<b>Signature of Health Care Provider:</b>		<b>Printed Name:</b>

**SECTION 5. SUSPENSION OF PRIOR AUTHORIZATION DUE TO LACK OF INFORMATION**

<b>C A R R I E R</b>	Suspension of Prior Authorization Process due to Lack of Information		
	<input type="checkbox"/> The requested Treatment or Testing is delayed due to a Suspension of Prior Authorization Due to Lack of Information		
	I hereby certify that this Suspension of Prior Authorization was	<input type="checkbox"/> Faxed	to the Health Care Provider on this the _____ day of _____, _____
		<input type="checkbox"/> Emailed	(day) (month) (year)
<b>Signature of Carrier/Self Insured Employer:</b>		<b>Printed Name:</b>	

<b>P R O V I D E R</b>	Appeal of Suspension to Medical Services Section by Health Care Provider		
	I hereby certify that this form and all information previously submitted to Carrier/Self Insured Employer was faxed to OWCA Medical Services (Fax Number: 225-342-9836) this _____ day of _____, _____.		
	I hereby certify that this Appeal of Suspension of Prior Authorization was	<input type="checkbox"/> Faxed	to the Carrier/Self Insured Employer on this the _____ day of _____, _____
		<input type="checkbox"/> Emailed	(day) (month) (year)
<b>Signature of Health Care Provider:</b>		<b>Printed Name:</b>	

**SECTION 6. DETERMINATION OF MEDICAL SERVICES SECTION**

<b>O W C A</b>	<input type="checkbox"/> The required information of LAC40:2715(C) was <i>not</i> provided		
	<input type="checkbox"/> The required information of LAC40:2715(C) was provided		
	I hereby certify that a written determination was	<input type="checkbox"/> Faxed	to the Health Care Provider & Carrier/Self Insured Employer on this the _____ day of _____, _____
		<input type="checkbox"/> Emailed	(day) (month) (year)
<b>Signature:</b>		<b>Printed Name:</b>	

**SECTION 7. HEALTH CARE PROVIDER RESPONSE TO MEDICAL SERVICES DETERMINATION**

<b>P R O V I D E R</b>	I hereby certify that additional information, pursuant to the determination of Medical Services Section, was		
		<input type="checkbox"/> Faxed	to the Carrier/Self Insured Employer on this the _____ day of _____, _____
		<input type="checkbox"/> Emailed	(day) (month) (year)
	<b>Signature of Health Care Provider:</b>		<b>Printed Name:</b>



B. LWC Form 1010A—First Request

**LWC FORM 1010A - FIRST REQUEST**  
PLEASE PRINT OR TYPE

SECTION 1. IDENTIFYING INFORMATION				
<b>P A T I E N T</b>	Last Name:	First:	Middle:	Social Security Number:
	Employers Name:			Claim Number (if known):
SECTION 2. CARRIER/SELF INSURED EMPLOYER'S FIRST REQUEST FOR REQUIRED MINIMUM INFORMATION				
<b>C A R R I E R</b>	I have received a request for authorization for the above referenced matter and have determined it lacks the required minimum information of 40:2715(C) - Please check all that apply			
	<input type="checkbox"/> History provided to the level of condition and as provided by Medical Treatment Schedule			
	<input type="checkbox"/> Physical Findings/Clinical Tests			
	<input type="checkbox"/> Documented functional improvements from prior treatment			
	<input type="checkbox"/> Test/imaging results			
	<input type="checkbox"/> Treatment Plan including services being requested along with the frequency and duration			
	<b>COMMENTS</b>			
	(Please provide a detailed explanation in support of your First Request)			
SECTION 3. HEALTH CARE PROVIDER RESPONSE TO FIRST REQUEST				
<b>P R O V I D E R</b>	<input type="checkbox"/> Additional information has been provided - Attach Supporting Documentation			
	<input type="checkbox"/> Additional information has not been provided - Provide explanation below			
	<b>EXPLANATION</b>			

AUTHORITY NOTE: Promulgated in accordance with RS 23:1203.1.

HISTORICAL NOTE: Promulgated by the Workforce Commission, Office of Workers' Compensation Administration, LR 38:1037 (April 2012), amended LR 38:3255 (December 2012), LR 42:286 (February 2016).

**§2719. Instructions for On-Site Audit of Hospital Charges by Workers' Compensation Carrier**

A. The carrier is authorized to conduct an on-site audit of hospital services related to a compensable injury or illness. This is accomplished by a line-by-line examination of billed charges, comparing the doctor's orders with supporting

medical documentation in the patient's chart and the corresponding departmental records.

B. The following audit guidelines will be followed by hospitals and carrier/self-insured employer. Disputes between the carrier/self-insured employer and hospitals will be referred to the Office of Workers Compensation for final resolution.

1. Carrier/Self-Insured Employer Responsibilities

a. The claims to be audited should be identified as quickly as possible after the carrier/self-insured employer receives the claim.

## LABOR AND EMPLOYMENT

b. The carrier/self-insured employer or its audit agency should give 10 calendar days advance notice to the hospital of its desire to perform an audit. The carrier/self-insured employer or its audit agency should make an appointment to do the audit at the time that is mutually agreed to by both parties. At the time the appointment is made, the hospital shall be informed of:

- i. the name(s) of patient(s) whose records are to be audited;
- ii. the admission and discharge dates for each case;
- iii. the medical record numbers and billing numbers of the claims to be audited, as assigned by the hospital, if those appear on the claim;
- iv. the name(s) of the auditor(s) who will conduct the audit, if available, and the name of the audit firm if the carrier/self-insured employer is contracting for auditing services;
- v. the portion of the bill to be audited (i.e., drugs, respiratory therapy, etc.) if the entire bill is not to be audited.

c. Qualified individuals familiar with hospital billing practices, medical terminology and medical record charting must be used to perform the billing audit.

d. Auditors must be properly authorized and identified as representatives of the carrier/self-insured employer or its audit agency.

e.i. Recognizing that no single standard exists for the payment of hospital bills prior to audit, or for audit fees charged by hospitals, the Office of Workers' Compensation recommends the following guidelines.

(a). The carrier/self-insured employer should pay at least 80 percent of billed charges prior to the audit. If an audit fee is charged by the provider, it should not exceed \$50 per patient record plus copy charges as provided below.

(b). The carrier/self-insured employer will reimburse the hospital for copies of medical records at the following rates: Fees will not exceed \$15 per record for 1-20 pages, and \$0.30 per page for records in excess of 20 pages. Microfilm copies will not exceed \$0.50 per page.

ii. Should the carrier/self-insured employer and hospital not be able to agree to this standard or some other standard, either party may submit the dispute to the Office of Workers' Compensation Administration in the same manner and subject to the same procedures as established for dispute resolution of claims for workers' compensation benefits.

f. Auditors should itemize specific unsupported charges and unbilled charges found on hospital bills. The final audit findings will offset unbilled charges against unsupported charges in a reconciliation process to be completed by the carrier/self-insured employer after receiving the audit report which should include a listing of all unbilled charges and unsupported billings.

g. Auditors should conduct exit interviews with a hospital's audit coordinator and/or other appropriate hospital

personnel prior to leaving to permit the review of the preliminary audit results before issuing a final report. If the exit interview is waived by the hospital, this fact should be indicated in writing.

h. A written report of the final audit results should be sent to all interested parties in a timely fashion.

### 2. Hospital Responsibilities

a. Hospitals must schedule an appointment to audit a bill promptly upon the receipt of a request for such an appointment, at a time mutually agreed upon by the hospital and the carrier/self-insured employer or its audit agency no later than 10 days from receipt of request.

b. Hospitals should respond promptly to a request for an itemized bill from the carrier/self-insured employer or its agent.

c. Hospitals should respond promptly to requests for additional information on the period of hospitalization, including information from the medical record and from the billing office.

d. Hospitals should designate one individual to be responsible for coordinating all hospital audit activities, and act as a liaison between provider personnel and the carrier/self-insured employer. This would include informing appropriate hospital departments of pending audits and audit results, answering carrier/self-insured employer questions, insuring that a late charge bill is sent to the patient or carrier/self-insured employer, issuing a refund to the appropriate party, etc. After notice of a proposed audit has been received by the hospital, this individual should coordinate between the medical records department and the billing office to insure that medical records, financial records, and any other documentation needed to substantiate charges are provided and available for the audit.

e. The hospital liaison shall acquaint the carrier/self-insured employer representative or audit agent with its record system and charging practices.

f. All substances administered to the patient in any form, as well as all treatments or medical services, must be specifically and accurately documented.

g. The hospital's representative will be available to the carrier/self-insured employer to conduct an exit interview. Discrepancies will be reviewed, resolved, and agreed upon by both parties. This will be done by written confirmation of the unbilled and/or undocumented charges identified during the audit and signed by both parties. In the event that same day resolution is not possible, the hospital, in a timely manner, should resolve differences in any unsupported or unbilled amounts resulting from the audit.

h. The hospital should issue refunds promptly if overcharges and/or undocumented charges exceeding the balance of the carrier/self-insured employer liability are discovered during the audit.

i. Hospitals may not bill for undocumented charges discovered during the bill audit process. However, hospitals

may bill for documented and previously unbilled charges discovered during the bill audit process, for charges in excess of the audit fee charged by the hospital.

**AUTHORITY NOTE:** Promulgated in accordance with R.S. 23:1291.

**HISTORICAL NOTE:** Promulgated by the Department of Employment and Training, Office of Workers' Compensation, LR 17:263 (March 1991), repromulgated LR 17:653 (July 1991).

## Chapter 29. Pharmacy Reimbursement Schedule, Billing Instruction and Maintenance Procedures

Editor's Note: Other Sections applying to this Chapter can be found in Chapter 51.

### §§2901-2903. Reserved.

### §2905. Covered Services

A. Drugs prescribed by the treating or a consulting physician for an occupational injury or disease are reimbursable under workers' compensation. If a drug is prescribed for other than primary treatment of the compensable condition the treating physician must provide written justification. For example, a weight control drug may be necessary to reduce a person's weight in order to relieve pain and enable proper strengthening and treatment of a back injury; or, an antidepressant may be prescribed to enhance an analgesic.

B. Durable medical equipment, prosthetics, and nonreusable supplies are also reimbursable to pharmacies but must be billed on the HCFA 1500 Form. National Drug Codes (NDCs) are not acceptable for the billing of supplies. Separate billing instructions are provided for these services. Refer to the appropriate reimbursement schedule.

C. Medication paid for by a claimant will be reimbursed directly to the claimant. In order for the claimant to bill the carrier/self-insured employer, the pharmacist must furnish the claimant with a signed receipt and a nonnegotiable copy of each prescription including the national drug code and quantity. The pharmacy billing must include only the actual amount billed for the amount of drugs being dispensed on any one visit.

**AUTHORITY NOTE:** Promulgated in accordance with R.S. 23:1034.2.

**HISTORICAL NOTE:** Promulgated by the Department of Labor, Office of Workers' Compensation, LR 19:54 (January 1993), repromulgated LR 19:212 (February 1993), amended LR 20:1299 (November 1994).

### §2907. Reimbursement

A. Payment for brand-name pharmaceuticals including oral non-legend drugs will be made at the lesser of:

1. the provider's usual charge;
2. a provider/insurer contracted charge; or
3. the average wholesale price (AWP) plus 10 percent plus a dispensing fee equal to the Medicaid dispensing fee set

by the state of Louisiana, Department of Health and Hospitals.

B. Payment for generic pharmaceuticals will be made at the lesser of:

1. the provider's usual charge;
2. a provider/insurer contracted charge; or
3. the average wholesale price (AWP) plus 40 percent, plus a dispensing fee equal to the Medicaid dispensing fee set by the state of Louisiana, Department of Health and Hospitals.

C. The average wholesale prices (AWPs) for brand-name and generic pharmaceuticals will be the AWP listed in the most recent monthly update of the *Annual Pharmacists' Reference Red Book* available from:

Medical Economics Company, Inc.  
680 Kinderkamack Road  
Oradell, NJ 07649  
Phone (800) 526-4870

D. Compounded prescriptions will be paid utilizing the same reimbursement formula as generic drugs. Please write "COMPOUND RX" directly above the RX# field on the Drug Claim Form.

E. When not in conflict with physician's orders and/or when not contrary to stop orders, medications should be dispensed in quantities sufficient to last 30 days except pharmaceuticals which could be considered "one-a-day, long-term maintenance" drugs, which may be dispensed in 100 unit dose quantities.

F. Refills will be permitted on an original prescription for a period of not more than one year from the date of such prescription, subject to applicable laws and regulations and only in accordance with the authorization of the prescribing physician.

**AUTHORITY NOTE:** Promulgated in accordance with R.S. 23:1034.2.

**HISTORICAL NOTE:** Promulgated by the Department of Labor, Office of Workers' Compensation, LR 19:54 (January 1993), repromulgated LR 19:212 (February 1993), amended LR 20:1299 (November 1994).

### §2909. Noncovered Services

A. The workers' compensation insurer will not make payment for:

1. over-the-counter (OTC) drugs and supplies unless prescribed by the treating physician of record. All over-the-counter and Schedule V preparations must be prescribed by a medical practitioner licensed to write prescriptions. Approved OTC drugs are reimbursed the same as legend drugs;
2. drugs or disposable needles and syringes dispensed while a patient in a hospital, nursing home, or other institution;
3. experimental or investigative drugs which have not been approved by FDA;

## LABOR AND EMPLOYMENT

4. vitamins, vitamin injections, or vitamin therapy of any kind;

5. diet pills or drugs for the purpose of weight reduction unless the treating physician can provide prior justification;

6. charges for any prescription, or item of merchandise or service, not related to the qualifying illness or injury;

7. pharmacy charges incurred in conjunction with non-work related conditions; or

8. items or services which are furnished gratuitously without regard to the individual's ability to pay, and without expectation of payment from any source.

AUTHORITY NOTE: Promulgated in accordance with R.S. 23:1034.2.

HISTORICAL NOTE: Promulgated by the Department of Labor, Office of Workers' Compensation, LR 19:54 (January 1993), repromulgated LR 19:212 (February 1993), amended LR 20:1299 (November 1994).

### §§2911-2913. Reserved.

#### §2915. Billing Instructions

A. Pharmaceutical billing must occur on either the CMS 1500 or a company invoice. Billing document will include the following minimum information:

1. claimant name;
2. claimant address;
3. unique claimant identifier;
4. date prescription was filled;
5. national drug code;
6. drug name;
7. drug quantity;
8. total charge;
9. number of days prescribed;
10. prescribing providers name;
11. prescribing providers NPI;
12. pharmacists I.D.;
13. dispensing facility address;
14. dispensing facility phone number;
15. medication charge; and
16. dispensing fee charge.

B. Entities issuing reimbursement documentation will include the following information:

1. claimant name;
2. claimant address;
3. unique claimant identifier;
4. date prescription was filled;

5. national drug code;

6. drug name;

7. amount charged per prescription;

8. total amount charged;

9. individual drug reimbursement;

10. total bill reimbursement;

11. individual tax reimbursement;

12. total tax reimbursement;

13. total amount reimbursed;

14. payor name;

15. payor address; and

16. payor phone number.

#### C. Item by Item Instructions for Completion of the Drug Form

1. Group Number—leave blank.
2. Cardholder's I.D. Number—enter claimants Social Security number.
3. Cardholder's Name—enter claimant's full name.
4. Pharmacy Name—enter name of pharmacy.
5. Street No.—enter physical address of pharmacy.
6. City, State, Zip—enter pharmacy city, state and zip.
7. Pharmacy No.—leave blank.
8. Phone Number—enter telephone number of pharmacy.
9. Other Party Coverage—leave blank.
10. Claimant's Last Name, First Name and Middle Initial—enter claimant's name.
11. Date of Birth—enter month, day, year.
12. Sex—check the appropriate box.
13. Relationship to the Cardholder—should be same as claimant.
14. Patient/Authorized Representative—signature must be present. If signature is on file at the pharmacy, then indicate "signature on file" in the patient's signature box.
15. Authorized Pharmacy Representative—enter pharmacist's name.
16. Date Rx Written—enter date prescription originally written.
17. Date Rx Filled—enter date of purchase.
18. Rx Number—indicate the alpha and/or numeric prescription number assigned by the pharmacy as it appears on the prescription order. Omit spaces or punctuation.
19. New/Refill—check the appropriate box.

20. Metric Quantity—report the quantity of the drug dispensed.

21. Days Supply—indicate days supply for which the prescription is dispensed.

22. National Drug Code—enter the 11 digit national drug code which identifies the drug dispensed.

- a. Labeler Code—first five digits;
- b. Product Code—middle four digits;
- c. Package Code—last two digits.

23. Prescriber I.D.—leave blank.

24. - 29. Complete same as Items 18-23 if second prescription is filed.

30. INGR Cost—indicate the *Red Book* AWP.

31. DISP Fee—leave blank.

32. Tax—do not complete.

33. Total Price—enter your normal retail charge (total price).

34. DED Amt—leave blank.

35. Balance—leave blank.

AUTHORITY NOTE: Promulgated in accordance with R.S. 23:1034.2.

HISTORICAL NOTE: Promulgated by the Department of Labor, Office of Workers' Compensation, LR 19:54 (January 1993), repromulgated LR 19:212 (February 1993), amended LR 20:1299 (November 1994), amended by the Workforce Commission, Office of Workers' Compensation, LR 38:837 (March 2012).

§§2917-2927. Reserved.

## Chapter 31. Vision Care Services, Reimbursement Schedule, Billing Instruction and Maintenance Procedures

Editor's Note: Other Sections applying to this Chapter can be found in Chapter 51.

§§3101-3113. Reserved.

### §3115. Covered Services

A. Only optical services necessitated by an occupational injury or illness are covered. Such services are provided as a result of damage to the eye(s) due to a work injury or exposure. In addition, frames, lenses and contact lenses not originally purchased by the carrier/self-insured employer will be replaced if damaged or broken in a work-related accident, in accordance with the provisions of R.S. 23:1203.

B.1. There are three distinct types of services provided:

- a. professional service;
- b. optical fitting service; and
- c. eye appliance.

2. Ophthalmologists may provide all three services. Opticians may provide optical fittings and appliances only.

C. Follow-Up Services. The reimbursement allowed for contact lenses shall include the normal follow-up to check for proper fit, vision correction and comfort. Any other follow-up services routinely provided free of charge by the vendor to other patients or customers shall be provided free of charge to workers' compensation claimants.

AUTHORITY NOTE: Promulgated in accordance with R.S. 23:1034.2.

HISTORICAL NOTE: Promulgated by the Department of Labor, Office of Workers' Compensation, LR 19:54 (January 1993), repromulgated LR 19:212 (February 1993), amended LR 20:1299 (November 1994).

### §3117. Benefit Detail and Limitations

A. Certain items are not payable by the carrier/self-insured employer unless specifically justified on medical grounds or as a replacement for eyewear of like-quality damaged in an occupational accident. In other words, upgrades such as daily wear to extended wear contact lenses, or ordinary frames to designer frames are not reimbursable. If the claimant desires an upgrade, the carrier/self-insured employer should be billed for the frames or lenses which approximates the original item and the claimant must pay the difference.

B. The items subject to this limitation are:

1. sunglasses;
2. scratch resistant lenses;
3. antireflectant lenses;
4. photosensitive lenses; and
5. oversized lenses.

C. *Covered Vision Care Services* includes exams, lenses, frames, and contact lenses prescribed by a licensed physician (M.D. or D.O.), or by an optometrist (O.D.). Prior approval is required from the carrier/self-insured employer.

D. Lenses must be equal in quality to the first quality lenses series manufactured by American Optical, Bausch and Lomb, or Univis, and must meet Z80.1 or Z80.2 standards of the American National Standards Institute.

E. Standard eyeglass frames adequate to hold lenses which qualify for payment are covered. Any additional charges for "oversize" or designer frames are considered optional and are the claimant's liability.

F. Therapeutic contact lenses:

1. are covered if the patient's visual acuity cannot otherwise be corrected to 20/70 in the better eye;
2. are covered if they are the only effective treatment; and
3. include the fee for cleaning and storage kits.

G. The contact lens suitability exam:

LABOR AND EMPLOYMENT

1. is included in the dispensing fee if the claimant is able to wear contact lenses;

2. is payable as a separate expense if the claimant is unable to wear contact lenses.

H. Prism, slab-off prism, and special base curve lenses are covered when prescribed because of therapeutic necessity.

I. Payment for covered frames and lenses is based on the provider's net acquisition cost comprising the material costs and laboratory costs, and the dispensing fee.

1. *Net Acquisition Cost* includes the frame, the lens ground on both sides with the edges ground for placement in the frame, plus laboratory costs associated with mounting in the frame; and applicable sales tax. The components of net acquisition cost are:

- a. material costs:
  - i. actual cost for materials, excluding charges for laboratory services;
  - ii. cost of lens blank purchased directly from the manufacturer or wholesaler; and
  - iii. rose tints or their equivalent, when prescribed for therapeutic reasons; and
- b. laboratory costs;
  - i. includes grinding to prescription;
  - ii. safety hardening;
  - iii. drop ball testing;
  - iv. coating and edging;
  - v. application of tints when prescribed, if not provided by manufacturer;
  - vi. assembly; and
  - vii. laboratory overhead.

2. *Dispensing Fee*—the fee that compensates a provider for dispensing lenses and frames as specified under this program. The dispensing fee includes measuring and verifying the lens as well as selecting, fitting, and adjusting the frames. A separate dispensing fee would be applicable for single vision, bifocal, and trifocal lenses. Contact lenses and special lenses are given individual consideration based on reported details and circumstances.

J. The maximum allowable reimbursement for professional services described by CPT codes are contained in the CPT Code Reimbursement Manual.

AUTHORITY NOTE: Promulgated in accordance with R.S. 23:1034.2.

HISTORICAL NOTE: Promulgated by the Department of Labor, Office of Workers' Compensation, LR 19:54 (January 1993), repromulgated LR 19:212 (February 1993), amended LR 20:1299 (November 1994).

**§3119. Maximum Allowable Reimbursement**

A. Maximum allowable reimbursement lists the maximum payment allowed for vision items described by HCPCS codes. Payment will be the least of:

- 1. the provider's usual and customary fee;
- 2. a pre-negotiated amount between the provider and carrier/self-insured employer; or
- 3. the amount indicated in the maximum allowable reimbursement schedule.

State of Louisiana Office of Workers' Compensation Schedule of Maximum Allowances for Vision Services and Supplies		
HCPCS	Description	Purchase New
V2020	Frames; Purchases	\$74
V2025	Deluxe Frame	B.R.
V2100	Sphere; Single Vision	\$50
V2101	Sphere; Single Vision	\$58
V2102	Sphere; Single Vision	\$60
V2103	Spherocylinder; Single Vision	\$38
V2104	Spherocylinder; Single Vision	\$54
V2105	Spherocylinder; Single Vision	\$57
V2106	Spherocylinder; Single Vision	\$59
V2107	Spherocylinder; Single Vision	\$65
V2108	Spherocylinder; Single Vision	\$59
V2109	Spherocylinder; Single Vision	\$59
V2110	Spherocylinder; Single Vision	\$61
V2111	Spherocylinder; Single Vision	\$63
V2112	Spherocylinder; Single Vision	\$86
V2113	Spherocylinder; Single Vision	\$78
V2114	Spherocylinder; Single Vision	\$100
V2115	Lenticular; (Myodisc); per Lens	\$101
V2118	Aniseikonic Lens; Single Vision	\$85
V2121	Lenticular lens, per lens, single	\$93
V2199	Not Otherwise Classified	B.R.
V2200	Sphere; Bifocal	\$66
V2201	Sphere; Bifocal	\$66
V2202	Sphere; Bifocal	\$92
V2203	Spherocylinder; Bifocal	\$65
V2204	Spherocylinder; Bifocal	\$69
V2205	Spherocylinder; Bifocal	\$74
V2206	Spherocylinder; Bifocal	\$83
V2207	Spherocylinder; Bifocal	\$66
V2208	Spherocylinder; Bifocal	\$91
V2209	Spherocylinder; Bifocal	\$77
V2210	Spherocylinder; Bifocal	\$87
V2211	Spherocylinder; Bifocal	\$80
V2212	Spherocylinder; Bifocal	\$89
V2213	Spherocylinder; Bifocal	\$120
V2214	Spherocylinder; Bifocal	\$125
V2215	Lenticular (Myodisc); per Lens	\$93
V2216	Lenticular; Nonaspheric; per Lens	\$91
V2217	Lenticular; Aspheric Lens; Bifocal	\$108
V2218	Aniseikonic; per Lens; Bifocal	\$105
V2219	Bifocal Seg Width over 28mm	\$59
V2220	Bifocal Add over 3.25d	\$60
V2221	Lenticular lens, per lens, bifocal	\$109
V2299	Specialty Bifocal (by report)	B.R.
V2300	Sphere; Trifocal	\$81
V2301	Sphere; Trifocal	\$104
V2302	Sphere; Trifocal	\$101
V2303	Spherocylinder; Trifocal	\$76
V2304	Spherocylinder; Trifocal	\$82
V2305	Spherocylinder; Trifocal	\$116

State of Louisiana Office of Workers' Compensation Schedule of Maximum Allowances for Vision Services and Supplies		
HCPCS	Description	Purchase New
V2306	Sphero-cylinder; Trifocal	\$124
V2307	Sphero-cylinder; Trifocal	\$91
V2308	Sphero-cylinder; Trifocal	\$92
V2309	Sphero-cylinder; Trifocal	\$94
V2310	Sphero-cylinder; Trifocal	\$98
V2311	Sphero-cylinder; Trifocal	\$109
V2312	Sphero-cylinder; Trifocal	\$101
V2313	Sphero-cylinder; Trifocal	\$105
V2314	Sphero-cylinder; Trifocal	\$111
V2315	Lenticular; (Myodisc); per Lens	\$118
V2316	Lenticular Nonaspheric; per Lens	\$111
V2317	Lenticular; Aspheric Lens	\$138
V2318	Aniseikonic Lens; Trifocal	\$156
V2319	Trifocal Seg Width over 28mm	\$75
V2320	Trifocal Add over 3.25d	\$84
V2321	Lenticular lens, per lens, trifocal	\$145
V2399	Specialty Trifocal (by report)	B.R.
V2410	Variable Asphericity Lens	\$147
V2430	Variable Asphericity Lens; Bifocal	\$141
V2499	Variable Sphericity Lens	B.R.
V2500	Contact Lens; PMMA; Spherical	\$125
V2501	Contact Lens; PMMA; Toric or Prism	\$134
V2502	Contact Lens PMMA; Bifocal	\$154
V2503	Contact Lens PMMA; Color Vision	\$145
V2510	Contact Lens; Gas Permeable	\$171
V2511	Contact Lens; Gas Permeable; Toric	\$186
V2512	Contact Lens; Gas Permeable	\$277
V2513	Contact Lens; Gas Permeable	\$252
V2520	Contact Lens Hydrophilic	\$128
V2521	Contact Lens Hydrophilic; Toric	\$193
V2522	Contact Lens Hydrophilic; Bifocal	\$262
V2523	Contact Lens Hydrophilic; Extended	\$181
V2530	Contact Lens; Scleral; per Lens	\$277
V2531	Contact lens, scleral, gas permeable, per lens	\$783
V2599	Contact Lens; Other Type	B.R.
V2600	Hand Held Low Vision Aids	B.R.
V2610	Single Lens Spectacle Mounted	B.R.
V2615	Telescopic and Other Compound Lens	B.R.
V2623	Prosthetic Eye; Plastic; Custom	\$1,384
V2624	Polishing Artificial Eye	\$78
V2625	Enlargement of Ocular Prosthesis	\$374
V2626	Reduction of Ocular Prosthesis	\$259
V2627	Scleral Cover Shell	\$1,412
V2628	Fabrication and Fitting	\$367
V2629	Prosthetic Eye; Other Type	B.R.
V2630	Anterior Chamber Intraocular Lens	\$534
V2631	Iris Supported Intraocular Lens	\$534
V2632	Posterior Chamber Intraocular Lens	\$453
V2700	Balance Lens; per Lens	\$52
V2702	Deluxe lens feature	B.R.
V2710	Slab off Prism; Glass or Plastic	\$78
V2715	Prism; per Lens	\$19
V2718	Press-on Lens; Fresnell Prism	\$41
V2730	Special Base Curve	\$33
V2744	Tint; Photochromatic; per Lens	\$20
V2745	Addition to lens; tint, any color, solid, gradient or equal, excludes photochromatic, any lens material, per lens	\$13
V2750	Anti-Reflective Coating; per Lens	\$26
V2755	UV Lens; per Lens	\$27
V2756	Eye glass case	\$6
V2760	Scratch Resistant Coating	\$17

State of Louisiana Office of Workers' Compensation Schedule of Maximum Allowances for Vision Services and Supplies		
HCPCS	Description	Purchase New
V2761	Mirror coating, any type, solid, gradient or equal, any lens material, per lens	B.R.
V2762	Polarization, any lens material, per lens	B.R.
V2770	Occluder Lens; per Lens	\$29
V2780	Oversize Lens; per Lens	\$15
V2781	Progressive lens, per lens	B.R.
V2782	Lens, index 1.54 to 1.65 plastic or 1.60 to 1.79 glass, excludes polycarbonate, per lens	\$71
V2783	Lens, index greater than or equal to 1.66 plastic or greater than or equal to 1.80 glass, excludes polycarbonate, per lens	\$80
V2784	Lens, polycarbonate or equal, any index, per lens	\$52
V2785	Processing; Transp Corneal Tissue	B.R.
V2786	Specialty occupational multifocal lens, per lens	B.R.
V2787	Astigmatism correcting function of intraocular lens	B.R.
V2790	Amniotic membrane for surgical reconstruction, per procedure	B.R.
V2797	Vision supply, accessory and/or service component of another hcpcs vision code	B.R.
V2799	Vision Service; Miscellaneous	B.R.

AUTHORITY NOTE: Promulgated in accordance with R.S. 23:1034.2.

HISTORICAL NOTE: Promulgated by the Department of Labor, Office of Workers' Compensation, LR 19:54 (January 1993), repromulgated LR 19:212 (February 1993), amended LR 20:1299 (November 1994), amended by the Workforce Commission, Office of Workers' Compensation, LR 39:1840 (July 2013).

§§3121-3139. Reserved.

### Chapter 33. Hearing Aid Equipment and Services Reimbursement Schedule, Billing Instructions and Maintenance Procedures

Editor's Note: Other Sections applying to this Chapter can be found in Chapter 51.

§§3301-3323. Reserved.

§3325. Covered Services

A. The carrier/self-insured employer will pay for a hearing aid to correct trauma-induced hearing loss. The purchase and use of the hearing aid must be shown to improve the claimant's hearing ability and must be prescribed by an ear, nose and throat specialist or by a physician possessing a certificate of clinical competence in audiology (CCCA).

B. Definitions

1. *Covered Hearing Aid Expense.* Covered Hearing Aid Expense includes charges incurred for audiometric examinations, hearing aid evaluation tests, and hearing aids to the extent that charges are reasonable and customary as set forth below:

a. audiometric examination performed by a physician or audiologist;

b. hearing aid evaluation test performed by a physician or audiologist, which may include the trial and testing of various makes and models of hearing aids to determine which make and model will best compensate for the loss of hearing acuity but only when indicated by the most recent audiometric examination;

c. hearing aids of the following functional design: in-the-ear, behind-the-ear and on-the-body, but only if:

i. the hearing aid is prescribed based upon the most recent audiometric examination and most recent hearing aid evaluation test; and

ii. the hearing aid provided by the dealer is the make and model prescribed by the physician or audiologist and is certified as such by the physician or audiologist.

In order for the charges for services and supplies described in §3325.B.1.a and b above to be covered, the audiometric examination must result in a determination that a hearing aid would compensate for the loss of hearing acuity.

2. *Provider*—a physician, audiologist or dealer.

a. *Physician*—an otologist or otolaryngologist who is board certified or eligible for certification in his/her specialty in compliance with the standards established by his/her respective professional sanctioning body, who is a licensed doctor of medicine or osteopathy legally qualified to practice medicine and who, within the scope of his/her license, performs a medical examination of the ear and determines whether the patient has a loss of hearing acuity and whether the loss can be compensated for by a hearing aid.

b. *Audiologist*—any person who meets the following criteria:

i. possesses a master's degree or doctorate degree in audiology or speech pathology from an accredited university;

ii. possesses a Certificate of Clinical Competence in Audiology or an Equivalency Certificate from the American Speech and Hearing Association; and

iii. is qualified, in the state in which the service is provided, to conduct an audiometric examination and hearing aid evaluation test for the purpose of measuring hearing acuity and determining and prescribing the type of hearing aid that would best improve the claimant's loss of hearing acuity.

(a). *Dealer*—any person or organization that sells hearing aids prescribed by a physician or audiologist to improve hearing acuity in compliance with the laws or regulations governing such sales.

3. *Hearing Aid*—

a. an electronic device worn on the person for the purpose of amplifying sound and assisting the physiologic process of hearing and includes the following, if necessary:

i. the single hearing aid unit;

ii. ear mold, necessary cords, tubing and connectors;

iii. standard package of batteries;

iv. earphone (often referred to as a receiver) or oscillator; and

v. one year warranty.

vi. The above mentioned hearing aid is covered by the carrier/self-insured employer only if:

(a). the claimant first obtains a medical examination of the ear by a physician and such examination, in conjunction with the audiometric examination, results in the determination that the prescribed hearing aid would compensate for the loss of hearing acuity; and

(b). the hearing aid provided by the dealer is the make and model prescribed by the physician or audiologist, unless any changes in the prescription are agreed upon by the physician or audiologist prior to dispensing the hearing aid.

4. *Ear Mold*—a device of soft rubber, plastic or nonallergenic material which may be vented or nonvented that individually is fitted to the external auditory canal and pinna of the patient.

5. *Dispensing Fee*—a fee to be paid to a dealer for dispensing hearing aids. This dispensing fee includes history (e.g., general information on patient environmental circumstances), fabrication and fitting of the ear mold, fitting the ear mold to the prescribed hearing aid, instructions in the wearing of the hearing aid and follow-up visits within a six-month period immediately following the fitting of the hearing aid.

6. *Audiometric Examination*—a procedure for measuring hearing acuity that includes history, procedures for measuring hearing acuity including tests relating to air conduction, bone conduction, speech reception threshold and speech discrimination, and summary and findings.

7. *Hearing Aid Evaluation Test*. The hearing aid evaluation test is defined in two components as follows.

a. *Hearing Aid Evaluation Test*—a series of subjective and objective tests by which a physician or audiologist determines which make and model of hearing aid will best compensate for the loss of hearing acuity and which make and model will therefore be prescribed.

b. *Conformity Evaluation (if a hearing aid is prescribed and fitted)*—one visit to the prescribing physician or audiologist by the claimant subsequent to obtaining the hearing aid for an evaluation of its performance and a determination of its conformity to the prescription.

8. *Hearing Aids*—

a. *Monaural*—the standard unit which provides amplified sound for one ear only.

b. *Cros (Contralateral Routing Signal) or "Cross Over" System*—places a microphone behind the poorer ear and feeds the amplified sound to the better ear.



c. *Bicros*—consists of two microphones which send signals to a single amplifier.

d. *Bilateral*—a body-worn aid which feeds the sound from a microphone and amplifier located on the body to both ears via a "Y" cord and two receivers.

e. *Binaural*—a hearing aid system consisting of two complete hearing aids, two microphones, two amplifiers and two receivers, one for each ear.

f. Eyeglass hearing aids which are mounted in the stem of a pair of eyeglasses also are payable but only up to the monaural payment level. Therefore, reimbursement for such aids may include payment for special eyeglass frame fronts and/or optics as needed to accommodate the eyeglass type aid, provided payment does not exceed the charge for the covered hearing aid expense for one basic behind-the-ear type aid.

AUTHORITY NOTE: Promulgated in accordance with R.S. 23:1034.2.

HISTORICAL NOTE: Promulgated by the Department of Labor, Office of Workers' Compensation, LR 19:54 (January 1993), repromulgated LR 19:212 (February 1993), amended LR 20:1299 (November 1994).

**§3327. Physician Dispensing of Hearing Aids**

A. Hearing aid evaluation tests are billable only when the evaluation is performed by a provider other than the hearing aid dispenser or if the test results indicate no hearing aid is needed.

AUTHORITY NOTE: Promulgated in accordance with R.S. 23:1034.2.

HISTORICAL NOTE: Promulgated by the Department of Labor, Office of Workers' Compensation, LR 19:54 (January 1993), repromulgated LR 19:212 (February 1993), amended LR 20:1299 (November 1994).

**§3329. Reimbursement Schedule**

A. The following Section, maximum allowable reimbursement, lists the maximum payment allowed for hearing items described by HCPCS codes. Payment will be the least of:

1. the provider's usual and customary fee;
2. a pre-negotiated amount between the provider and carrier/self-insured employer; or
3. the amount indicated in the maximum allowable reimbursement schedule.

State of Louisiana Office of Workers' Compensation Schedule of Maximum Allowances for Hearing Services and Supplies		
HCPCS	Description	Maximum Allowable
V5008	Hearing screening	\$35
V5010	Assessment for hearing aid	\$82
V5011	Fitting or checking of hearing aid	B.R.
V5014	Repair/modification of a hearing aid	\$117
V5020	Conformity evaluation	\$70
V5030	Hearing aid, monaural, body worn, air conduction	\$738
V5040	Hearing aid, monaural, body worn, bone conduction	\$767

State of Louisiana Office of Workers' Compensation Schedule of Maximum Allowances for Hearing Services and Supplies		
HCPCS	Description	Maximum Allowable
V5050	Hearing aid, monaural, in the ear (full shell only)	\$708
V5060	Hearing aid, monaural, behind the ear	\$720
V5070	Glasses, air conduction	\$802
V5080	Glasses, bone conduction	\$838
V5090	Dispensing fee, unspecified hearing aid	\$270
V5095	Semi-implantable middle ear hearing prosthesis	B.R.
V5100	Hearing aid, bilateral, body worn	\$1,061
V5110	Dispensing fee, bilateral	\$287
V5120	Binaural, body	\$1,160
V5130	Binaural, in the ear (full shell only)	\$1,378
V5140	Binaural, behind the ear	\$1,406
V5150	Binaural, glasses	\$1,388
V5160	Dispensing fee, binaural	\$334
V5170	Hearing aid, cros, in the ear (full shell only)	\$958
V5180	Hearing aid, cros, behind the ear	\$896
V5190	Hearing aid, cros, glasses	\$955
V5200	Dispensing fee, cros	\$282
V5210	Hearing aid, bicros, in the ear (full shell only)	\$1,049
V5220	Hearing aid, bicros, behind the ear	\$1,008
V5230	Hearing aid, bicros, glasses	\$1,042
V5240	Dispensing fee, bicros	\$311
V5241	Dispensing fee, monaural hearing aid, any type	B.R.
V5242	Hearing aid, analog, monaural, cic (completely in the ear canal)	B.R.
V5243	Hearing aid, analog, monaural, itc (in the canal)	B.R.
V5244	Hearing aid, digitally programmable analog, monaural, cic	B.R.
V5245	Hearing aid, digitally programmable, analog, monaural, itc	B.R.
V5246	Hearing aid, digitally programmable analog, monaural, ite (in the ear)	B.R.
V5247	Hearing aid, digitally programmable analog, monaural, bte (behind the ear)	B.R.
V5248	Hearing aid, analog, binaural, cic	B.R.
V5249	Hearing aid, analog, binaural, itc	B.R.
V5250	Hearing aid, digitally programmable analog, binaural, cic	B.R.
V5251	Hearing aid, digitally programmable analog, binaural, itc	B.R.
V5252	Hearing aid, digitally programmable, binaural, ite	B.R.
V5253	Hearing aid, digitally programmable, binaural, bte	B.R.
V5254	Hearing aid, digital, monaural, cic	B.R.
V5255	Hearing aid, digital, monaural, itc	B.R.
V5256	Hearing aid, digital, monaural, ite	B.R.
V5257	Hearing aid, digital, monaural, bte	B.R.
V5258	Hearing aid, digital, binaural, cic	B.R.
V5259	Hearing aid, digital, binaural, itc	B.R.
V5260	Hearing aid, digital, binaural, ite	B.R.
V5261	Hearing aid, digital, binaural, bte	B.R.
V5262	Hearing aid, disposable, any type, monaural	B.R.
V5263	Hearing aid, disposable, any type, binaural	B.R.
V5264	Ear mold/insert, not disposable, any type	B.R.
V5265	Ear mold/insert, disposable, any type	B.R.
V5266	Battery for use in hearing device	B.R.
V5267	Hearing aid supplies / accessories	B.R.
V5268	Assistive listening device, telephone amplifier, any type	B.R.
V5269	Assistive listening device, alerting, any type	B.R.
V5270	Assistive listening device, television amplifier, any type	B.R.

State of Louisiana Office of Workers' Compensation Schedule of Maximum Allowances for Hearing Services and Supplies		
HPCPS	Description	Maximum Allowable
V5271	Assistive listening device, television caption decoder	B.R.
V5272	Assistive listening device, tdd	B.R.
V5273	Assistive listening device, for use with cochlear implant	B.R.
V5274	Assistive listening device, not otherwise specified	B.R.
V5275	Ear impression, each	B.R.
V5298	Hearing aid, not otherwise classified	B.R.
V5299	Hearing aid, not otherwise classified	B.R.
V5336	Repair/modification augmen devise	B.R.
V5362	Speech screening	B.R.
V5363	Language screening	B.R.
V5364	Dysphagia screening	B.R.

AUTHORITY NOTE: Promulgated in accordance with R.S. 23:1034.2.

HISTORICAL NOTE: Promulgated by the Department of Labor, Office of Workers' Compensation, LR 19:54 (January 1993), repromulgated LR 19:212 (February 1993), amended LR 20:1299 (November 1994), amended by the Workforce Commission, Office of Workers' Compensation, LR 39:1840 (July 2013).

§§3331-3341. Reserved.

## Chapter 35. Nursing/Attendant Care and Home Health Services Reimbursement Schedule, Billing Instruction and Maintenance Procedures

Editor's Note: Other Sections applying to this Chapter can be found in Chapter 51.

§§3501-3505. Reserved.

### §3507. Prior Authorization

A.1. All nursing services and personal care services described herein, except those specifically noted, must have prior written authorization of the carrier/self-insured employer before reimbursement will be made. Claimants should be notified of this requirement in writing upon the initiation of the claim.

2. Each authorization request must include a prescription or statement of need from the treating physician of record. The information provided by the prescribing physician must include, at a minimum:

a. in addition to the medical report and written justification required above, a description of needed nursing or other attendant services, as well as specifying the level of nursing care (R.N., L.P.N., sitter/nonprofessional); and

b. estimated period of need, including daily/hourly requirements for each level of nursing care.

B. Prior authorization requests will be approved, denied, or amended and approved by the carrier/self-insured employer. Occasionally, some requests may be returned for

further information, explanation, or reports. Once a request is approved, please take great care to bill only for those procedures or services specifically authorized by the carrier/self-insured employer. In addition, please attach the authorization letter to the invoice or enter the prior authorization number in the appropriate field on the invoice.

AUTHORITY NOTE: Promulgated in accordance with R.S. 23:1034.2.

HISTORICAL NOTE: Promulgated by the Department of Labor, Office of Workers' Compensation, LR 19:54 (January 1993), repromulgated LR 19:212 (February 1993), amended LR 20:1299 (November 1994).

### §3509. Training Requirements and Reimbursement Guidelines

A. Payment may be made for authorized services to the following provider types, subject to the following guidelines.

1. Trained professional nursing personnel who provide services through the auspices of public or private home health agencies who are paid for their services by their employer.

2. Trained professional nursing personnel who are self-employed may be paid directly for their services at a rate not to exceed the maximum allowable reimbursement for nursing/attendant care services. Self-employed nurses and attendants are considered independent contractors by the carrier/self-insured employer; therefore, the carrier/self-insured employer takes no responsibility for producing income tax forms (such as W-2 Forms) for those individuals.

3. Nursing and personal care homes will be reimbursed at the approved per diem rates established for institutional services.

4. Nursing manpower agencies and home health agencies will be reimbursed using the same procedure codes and maximum allowable reimbursement schedule established for Nurse/Attendant Care Services.

5. Authorized services by nonprofessional family members are reimbursable up to eight hours in any 24-hour period. Any family member who is a medical professional may provide services under the same restrictions placed on self-employed nurses and attendants.

6. Family members and other persons who are not trained professional nursing personnel may receive payment in the amount of the current minimum wage if the following requirements have been satisfied:

a. the attendant has received adequate instruction from the authorized treating provider regarding the services to be provided in the home;

b. the services provided must be beyond the scope of normal household duties and must be in the nature of services ordinarily rendered by trained professional personnel in hospitals or nursing homes; and

c. the medical evidence of record must be sufficient to identify the nature and approximate value of the services provided.

7. The purpose of private duty nurses is to provide skilled constant attention and observation to a seriously ill patient. The need for, and the length of, service usually depends on the condition of the patient and the level of care required rather than the nature of the disease, illness, or condition.

8. Patients recovering from major surgery, severe systemic disease or one of the catastrophic diseases, frequently require a level of skilled care beyond that afforded by the general nursing service provided by a hospital or other institution.

9. The following are examples of services which require "skilled" personnel for proper administration. This list is not all-inclusive:

- a. intravenous injections and feeding;
- b. insertion and replacement of urethral catheters;
- c. dressing open or draining wounds involving prescription medications and aseptic techniques;
- d. insertion and replacement of tubes for gastric feedings;
- e. nasopharyngeal and tracheotomy aspiration;
- f. care of extensive decubitus ulcers (2 cm or greater), or care of other widespread skin disorders;
- g. initial phases of a regimen involving administrations of medical gases.

10. "Supportive" service to a patient is not necessarily a skilled service and may require only a nonprofessional level of care. For example, a nonambulatory patient may need frequent changes of position in the bed to avoid the development of ulcers. Changing of position can ordinarily be accomplished by untrained, nonprofessional personnel, so this is not considered a "skilled" service.

11. The following are specific activities which are not considered to be "skilled" nursing services and a person of lesser training can be utilized. This listing is not all-inclusive:

- a. administration of routine oral medications; eye drops; ointments;
- b. general maintenance care of colostomy or ileostomy;
- c. routine services in connection with indwelling bladder catheters (emptying and cleaning containers; clamping tubing; and refilling irrigation containers with solution);
- d. changes of dressings in noninfected postoperative or chronic conditions;
- e. prophylactic and palliative skin care; including bathing, and application of skin creams, or treatment of minor skin problems;
- f. general maintenance care in connection with a plaster cast;

- g. routine care in connection with braces and similar devices;
- h. administration of medical gases after the initial training of the patient in self-administration;
- i. general supervision of exercises which have been taught to the patient;
- j. assisting the patient in routine activities; dressing, eating, hygiene, etc.

AUTHORITY NOTE: Promulgated in accordance with R.S. 23:1034.2.

HISTORICAL NOTE: Promulgated by the Department of Labor, Office of Workers' Compensation, LR 19:54 (January 1993), repromulgated LR 19:212 (February 1993), amended LR 20:1299 (November 1994).

**§3511. Maximum Allowable Reimbursement**

A. Payment for nursing/attendant care services, (not to include home infusion therapy) will be made for the least of:

- 1. the provider's usual and customary fee;
- 2. a pre-negotiated amount between the provider and carrier/self-insured employer; or
- 3. the maximum allowable amounts as established by these rules.

B. In computing the number of Home Health Agency (HHA) visits rendered a patient eligible for Workers' Compensation benefits, each personal contact in the place of the residence of patient made for the purpose of providing a covered service by a health worker on the staff of a HHA or by others under contract or arrangement with a HHA shall be counted as a visit. A visit made simultaneously by two or more health workers from a HHA to provide a single covered service for which one person supervises or instructs the other shall be counted as one visit.

C. The following shall be used.

Code	Description	Allowance
W0050	Home health agency based health care employee (visit rate)	\$100
W0100	Home health agency based registered nurse (hourly rate)	\$ 44
W0110	Home health agency based licensed practical nurse (hourly rate)	\$ 31
W0120	Home health agency based nurses' aide, (hourly rate)	\$ 11
W0125	Home health agency based attendant, (hourly rate)	Minimum Wage
W0200	Self employed registered nurse, (hourly rate)	\$ 44
W0210	Self employed licensed practical nurse, (hourly rate)	\$ 31
W0220	Self employed nurses' aide, (hourly rate)	\$ 11
W0225	Self employed attendant, hourly rate	Min. Wage
W0325	Nonprofessional family member	Min. Wage
<b>Home Infusion Therapy</b>		
Per diem allowances reflect the necessary supplies for the safe and effective administration of the prescribed therapy. Supplies include intravenous pump with battery back-up alarm, pump administration sets, IV tubing, central line dressing kits, needles, syringes, saline, heparin, PRN adapters, tape, gauze, IV pole, alcohol pads, start kits, catheters, and other ordinary supplies as needed.		

LABOR AND EMPLOYMENT

Code	Description	Allowance
<b>Antibiotic Therapy</b>		
<b>Dosage per Day</b>		<b>Per Diem</b>
W0401	One dose per day	\$ 77 + AWP*
W0402	Two doses per day	\$ 94 + AWP
W0403	Three doses per day	\$110 + AWP
W0404	Four doses per day	\$127 + AWP
W0405	Over four doses per day	\$143 + AWP
*AWP means Average Wholesale Price as found in the most current monthly update of the Red Book.		
<b>Total Parenteral Nutrition</b>		
Per diem price reflects daily charge for any combination of standard dextrose, amino acid and additives and includes cost of skilled nurse visit. Lipids 10 percent (500cc) should be included at no additional charge based upon frequency of once a week		
	<b>Description</b>	<b>Per Diem</b>
W0502	1.0 to 1.6 liters of TPN daily	\$182
W0504	1.7 to 2.4 liters of TPN daily	\$215
W0506	2.5 liters or greater of TPN daily	\$248
<b>Additional Lipids</b>		
Allowance includes tubing and administration supplies.		
W0512	Lipids 10% (500ml)	\$33
W0514	Lipids 20% (500ml)	\$44
W0519	Special formulations	BR
<b>Pain Management</b>		
Allowances are based on use of five cassettes per month and include pump and administration sets.		
W0602	Pain management, drug and ingredients	\$86 + AWP
<b>Additional Cassettes</b>		
W0612	50 ML	\$39
W0614	100 ML	\$50
<b>Hydration</b>		
Allowance per day reflects use of standard fluids and supplies.		
W0702	One liter daily	\$58
W0704	Two liters daily	\$66
W0706	Three liters daily	\$75
W0708	Four liters daily	\$84
<b>Chemotherapy</b>		
W0802	Continuous infusion	\$99 + AWP
W0804	Bolus/push	\$88 + AWP
W0806	Intermittent infusion	\$50 + AWP
<b>Enteral Therapy</b>		
W0902	Enteral nutrient	\$22 + AWP

AUTHORITY NOTE: Promulgated in accordance with R.S. 23:1034.2.

HISTORICAL NOTE: Promulgated by the Department of Labor, Office of Workers' Compensation, LR 19:54 (January 1993), repromulgated LR 19:212 (February 1993), amended LR 20:1299 (November 1994).

§§3513-3535. Reserved.

## Chapter 37. Home and Vehicle Modification Reimbursement Schedule, Billing Instructions and Maintenance Procedures

Editor's Note: Other Sections applying to this Chapter can be found in Chapter 51.

§§3701-3705. Reserved.

### §3707. Prior Authorization

A. Requests for home or vehicle modifications will most often originate from the claimant or a vocational rehabilitation consultant.

B. A request for modification or repair of a dwelling must be substantiated by detailed estimates listing the following:

1. exact nature of work to be done;
2. itemized cost of materials; and
3. total cost of labor broken down by total hours and hourly rate.

C. Prior authorization requests will be approved, denied, or amended and approved by the carrier/self-insured employer. Occasionally, some requests may be returned for further information, explanation or reports. Once a request is approved, take great care to bill only for those modifications specifically authorized by the carrier/self-insured employer. In addition, a copy of the prior authorization letter should be attached to the invoice/billing.

AUTHORITY NOTE: Promulgated in accordance with R.S. 23:1034.2.

HISTORICAL NOTE: Promulgated by the Department of Labor, Office of Workers' Compensation, LR 19:54 (January 1993), repromulgated LR 19:212 (February 1993), amended LR 20:1299 (November 1994).

### §3709. Home Modifications

A. The main objective of the carrier/self-insured employer is to maintain the claimant in a home environment, thus avoiding prolonged or repeated hospitalization.

B. Written authorization detailing the approved modifications and their exact cost must be issued prior to the initiation of work to be done.

C. When a request for modification or repair of a dwelling is considered, the request must contain verification that the dwelling is owned by the claimant or that there is an agreement with the owner for long-term residence. Modifications and repairs will be made after a determination by carrier/self-insured employer staff as to needs in accordance with the following guidelines.

1. Home modifications considered by the carrier/self-insured employer will be limited to the interior of a residence with the exception of ramps, lifts, and porches necessary for access to and exit from the home. However, when the existing residence is constructed in such a manner as to severely limit the claimant's mobility, the carrier/self-insured employer may consider additional exterior modifications. Items that may not be included in a bid for a room addition include medicine cabinets, special lighting, special doorways (double doors, sliding glass doors, etc.) decks or porches (wider than what is necessary for accessibility).

2. When it is determined that the reasonable rearrangement of existing furniture, fixtures, appliances, etc. will eliminate barriers and make the dwelling accessible, the carrier/self-insured employer will not approve any interior modification.

D. The purchase of special appliances or devices will be made when such will promote a return to work, overcome a need for hospitalization or special nursing, and/or

substantially improve the mobility of the claimant. Each case will be considered on an individual basis.

E. Inspection and acceptance of the modifications should be made by the carrier/self-insured employer prior to final payment.

**AUTHORITY NOTE:** Promulgated in accordance with R.S. 23:1034.2.

**HISTORICAL NOTE:** Promulgated by the Department of Labor, Office of Workers' Compensation, LR 19:54 (January 1993), repromulgated LR 19:212 (February 1993), amended LR 20:1299 (November 1994).

### §3711. Vehicle Modifications

A. The carrier/self-insured employer will authorize modifications to vehicles only on the basis of medical necessity. Modifications will be limited to the following:

1. installation of hand controls; and
2. van modifications when transfers into and out of a sedan type vehicle are not possible.

B. The carrier/self-insured employer cannot purchase vehicles, but can provide for modifications to an existing vehicle or to a vehicle purchased by the claimant.

**AUTHORITY NOTE:** Promulgated in accordance with R.S. 23:1034.2.

**HISTORICAL NOTE:** Promulgated by the Department of Labor, Office of Workers' Compensation, LR 19:54 (January 1993), repromulgated LR 19:212 (February 1993), amended LR 20:1299 (November 1994).

### §3713. Reserved.

### §3715. Schedule of Maximum Allowances

A. The reimbursement allowances for home and vehicle modifications are determined by obtaining bids for the specific modifications. Maximum allowable reimbursement schedules cannot be preset or predetermined. A minimum of three bids should be obtained by the carrier/self-insured employer whenever possible.

B. The payment agreed to by the carrier/self-insured employer represents the maximum allowance and constitutes payment in full for the services. No additional charge to the claimant is allowed. No charge shall be submitted to the carrier/self-insured employer before the service has been performed. All home and vehicle modifications require prior authorization.

**AUTHORITY NOTE:** Promulgated in accordance with R.S. 23:1034.2.

**HISTORICAL NOTE:** Promulgated by the Department of Labor, Office of Workers' Compensation, LR 19:54 (January 1993), repromulgated LR 19:212 (February 1993), amended LR 20:1299 (November 1994).

### §§3717-3735. Reserved.

## Chapter 39. Medical Transportation Reimbursement Schedule, Billing Instructions, and Maintenance Procedures

Editor's Note: Other Sections applying to this Chapter can be found in Chapter 51.

### §§3901-3907. Reserved.

### §3909. Ambulance Services

A. Levels of Care. Transportation by ground ambulance has been determined to be of two levels of care: either basic life support (BLS) or advanced life support (ALS). The ALS level of care cannot be charged unless the services meet the requirements stated in the ALS definition below. The BLS level of care will be billed when the ALS level of care does not apply.

#### B. Definitions

1. Advanced Life Support. The advanced life support (ALS) base rate may be billed when the following requirements are met. For the trip being billed, at least one ALS service must have been provided. ALS services are defined as:

- a. administration of intravenous solutions by an emergency medical technician;
- b. airway management by an emergency medical technician or paramedic;
- c. endotracheal airway management by an emergency medical technician or paramedic;
- d. advanced cardiac life support performed by a paramedic;
- e. administration of drugs by a paramedic; and
- f. performance of any of the above by a registered nurse or physician.

2. Basic Life Support. The basic life support (BLS) base rate is applicable to ground ambulance transports not covered under the ALS definition above.

C. Covered Services. For the two types of ambulance transportation services, vendors will be reimbursed at a base rate plus mileage. The base rate includes all charges for the ambulance transportation service not otherwise listed as a covered HCPCS code. Reimbursable services are detailed in §3911, "Schedule of Maximum Allowances."

1. Emergency Situations. The carrier/self-insured employer will reimburse ambulance service from the scene of the accident to the hospital or from some other location in the event an emergency exists.

2. Nonemergency Transports. Nonemergency transports may be allowed when the claimant's medical or physical condition precludes use of other modes of transportation, or if a claimant needs to be transferred from

one inpatient medical facility to another because of specialized services. A report may be requested from the attending physician documenting the necessity.

3. Roundtrips. Except for residents of nursing homes or personal care homes, roundtrips are not reimbursable without prior authorization by the carrier/self-insured employer. Unless the claimant's physical condition will not permit, the claimant is expected to provide his/her own transportation home after receiving treatment at a medical facility. The carrier/self-insured employer may also reimburse roundtrips for other reasons if prior authorization has been obtained.

4. Air Transport. Air ambulance transportation services will be reimbursed when specialized emergency services are not available locally or when ground transportation would be a clear health or life-endangering alternative. When prior authorization has been obtained, nonemergency air transportation may be reimbursed.

**D. Noncovered Services**

1. Routine, nonemergency ambulance or emergency vehicle transports to the doctor, therapist or other medical practitioner because of a lack of transportation on the part of the claimant are not covered unless pre-authorized by the carrier/self-insured employer.

2. The advanced life support (ALS) base rate will not be reimbursed simply because an ambulance is "ALS equipped" or because specially trained personnel were present. The ALS transport must have been medically justified. The nature of the injury or illness must be described in the diagnosis field of the invoice for all ALS transports or the bills will be denied pending receipt of the required information, or reimbursed at a lesser level of care. Documentation should also be attached to invoices when billing for BLS transports.

3. Only loaded transport mileage is reimbursable. Return mileage on one-way transports is not reimbursable and should not be billed to the carrier/self-insured employer.

AUTHORITY NOTE: Promulgated in accordance with R.S. 23:1034.2.

HISTORICAL NOTE: Promulgated by the Department of Labor, Office of Workers' Compensation, LR 19:54 (January 1993), repromulgated LR 19:212 (February 1993), amended LR 20:1299 (November 1994).

**§3911. Schedule of Maximum Allowances**

A. This document provides the basis for identification of procedures to be reimbursed to transportation vendors. The coding source is the health care financing administration common procedure coding system (HCPCS). No other coding methodology will be accepted by the carrier/self-insured employer. Please do not bill using any of the modifiers. Modifiers will not affect payment and may cause your bill to be unnecessarily delayed.

B. This fee schedule provides the basis for reimbursement of medical transportation. Reimbursement is limited to the least of:

1. the provider's usual and customary charge;

2. a reimbursement amount previously negotiated by the provider and the carrier/self-insured employer; or

3. the maximum allowable reimbursement as determined by the following schedule.

State of Louisiana Office of Workers' Compensation Schedule of Maximum Allowances for Medical Transportation		
HCPCS	Description	Maximum Allowable
A0140	Nonemergency Transportation and Air Travel (Private or Commercial), Intra or Interstate	B.R.
A0999	Unlisted Ambulance Service	B.R.
A0380	Emergency Ambulance Service, BLS per Mile, One Way	\$6
A0390	Emergency Ambulance Service, (ALS) Per Mile, One Way	\$7
A0420	Ambulance Service, Waiting Time, One Half (1/2) Hour Increments, Rate per Unit (See Table Below)	\$42
A0422	Ambulance Service, Oxygen, Administration and Supplies, Life Sustaining Situation	B.R.
A0427	Emergency Ambulance Service, Advanced Life Support (ALS) Base Rate, All Inclusive Services, One Way	\$375
A0428	Nonemergency Transportation, Ambulance, Base Rate, One Way	\$169
A0429	Emergency Ambulance Service, BLS Rate One Way	\$258
A0430	Ambulance Service, Conventional Air Service One Way	B.R.
A0431	Ambulance Service, Air, Helicopter, v	B.R.

AUTHORITY NOTE: Promulgated in accordance with R.S. 23:1034.2.

HISTORICAL NOTE: Promulgated by the Department of Labor, Office of Workers' Compensation, LR 19:54 (January 1993), repromulgated LR 19:212 (February 1993), amended LR 20:1299 (November 1994), amended by the Workforce Commission, Office of Workers' Compensation, LR 39:1841 (July 2013).

**§§3913-3933. Reserved.**

**Chapter 41. Durable Medical Equipment and Supplies Reimbursement Schedule, Billing Instructions, and Maintenance Procedures**

Editor's Note: Other Sections applying to this Chapter can be found in Chapter 51.

**§§4101-4109. Reserved.**

**§4111. Durable Medical Equipment**

A. Durable medical equipment (DME) refers to those items which can withstand repeated use, are primarily used to serve a medical purpose, are generally not useful to a person in the absence of illness, injury or disease, and are appropriate for use in the claimant's home.

1. Covered Services. The carrier/self-insured employer reimburses for the purchase or rental of certain medical equipment and accessories and the purchase of certain medical supplies for the claimant's use in a noninstitutional

setting. Supplies and equipment for nursing home claimants are restricted by the terms of any negotiated agreement between the nursing home and the carrier/self-insured employer, except as detailed herein. All items must be prescribed by the claimant's treating physician.

NOTE: Allowances pertaining to oxygen and other respiratory equipment and services can be found in both this manual and the respiratory services manual. procedure codes and billing instructions for braces and supplies related to prosthetic devices may be found in the manual for prosthetic/orthopedic equipment. hearing aid information is found in the hearing aid equipment and services manual.

2. **Noncovered Services.** In general, only those supply and equipment items listed in the section of this manual entitled "maximum allowances" will be reimbursed. The use of otherwise unlisted HCPCS codes may be covered when medical necessity is documented.

3. **Nonlisted Items and Individual Consideration.** Occasionally, there may be a workers' compensation claim where the HCPCS code either does not appear on the schedule of maximum allowances or is designated as "by report (BR)." In these instances, where medical necessity has been documented, the carrier/self-insured employer should contact three DME Suppliers in the geographic area from which the claim originated and obtain charge information for the specific HCPCS code billed. The carrier will use the average of the three responses as the maximum allowance for the specific HCPCS code. This procedure may be repeated when necessary for other codes which fall into this category.

AUTHORITY NOTE: Promulgated in accordance with R.S. 23:1034.2.

HISTORICAL NOTE: Promulgated by the Department of Labor, Office of Workers' Compensation, LR 19:54 (January 1993), repromulgated LR 19:212 (February 1993), amended LR 20:1299 (November 1994).

#### **§4113. Equipment Rental/Purchase Guidelines**

A. Whenever the total of prospective rental payments for the period of medical need as stated by the prescribing physician equals or exceeds the maximum purchase price as set by the Office of Workers' Compensation Administration, the DME provider, prescribing physician and carrier/self-insured employer should recommend purchase instead of rental when communicating with the claimant. All items with a maximum allowable rate of \$150 or less will be allowed as purchases only, regardless of the expected period of medical need. If, however, a definite period of medical need cannot be determined at the time of the initial prescription, a rental authorization will be granted with following condition.

1. Rented DME is considered purchased equipment once the Monthly Rental Allowance equals the Purchase Allowance. The DME is then owned by the claimant and neither claimant, nor insurer, nor employer can be billed.

B. If a claimant's medical condition changes or does not improve as expected, a rental may be discontinued in favor of a purchase. The carrier/self-insured employer reserves the right to reevaluate the rental/purchase option at any time within the authorized rental period.

C. If death or other factors intervene, rental fees for equipment will terminate at the end of the month such circumstances occurred and no further payment will be made regardless of the original rental period authorized.

D. The return of rented equipment is the dual responsibility of the claimant and the DME supplier. The carrier/self-insured employer is not responsible and will not reimburse for additional rental periods solely because of a delay in equipment return.

AUTHORITY NOTE: Promulgated in accordance with R.S. 23:1034.2.

HISTORICAL NOTE: Promulgated by the Department of Labor, Office of Workers' Compensation, LR 19:54 (January 1993), repromulgated LR 19:212 (February 1993), amended LR 20:1299 (November 1994).

#### **§4115. Equipment Warranty and Repair Information**

A. Benefits are not provided for equipment repair or maintenance by the carrier/self-insured employer. The repair or maintenance of rented DME is the responsibility of the DME supplier at no additional charge to the claimant. The carrier/self-insured employer is responsible for DME repair and maintenance of purchased equipment (subject to warranty provisions).

B. For purchased DME, the DME supplier must provide a one-year warranty agreement to the claimant. If the warranty agreement requires some nominal monetary fee, it is billable to the carrier/self-insured employer. The DME supplier must always inform the claimant about any DME warranty provided by the manufacturer.

AUTHORITY NOTE: Promulgated in accordance with R.S. 23:1034.2.

HISTORICAL NOTE: Promulgated by the Department of Labor, Office of Workers' Compensation, LR 19:54 (January 1993), repromulgated LR 19:212 (February 1993), amended LR 20:1299 (November 1994).

#### **§4117. Billing Instructions**

A. All initial claims for the rental or purchase of DME must be filed with a statement of medical necessity. The authorized physician should supply the durable medical equipment provider with a prescription stating the medical necessity for such services with the claimant's diagnosis, prognosis, and expected time span for which the equipment or supplies will be required. The recommended form for this information is on the following page. The form should be presented to the DME Supplier by the claimant and must be attached to the initial claim form for the rental or purchase of DME.

LABOR AND EMPLOYMENT

B. DME Certification Form

		<b>DURABLE MEDICAL EQUIPMENT CERTIFICATION</b>		
<p><b>THIS FORM MUST BE COMPLETED BY THE PHYSICIAN PRESCRIBING THE EQUIPMENT AND ATTACHED TO THE CLAIM FILED BY THE SUPPLIER</b></p>				
PATIENT'S NAME	AGE	CONTRACT NO.		
EQUIPMENT PRESCRIBED		DATE PRESCRIBED		
DIAGNOSIS				
LIMITATIONS (Check all conditions applicable)				
<input type="checkbox"/> Weakness of arm(s) <input type="checkbox"/> Confined to chair <input type="checkbox"/> Other <input type="checkbox"/> Weakness of leg(s) <input type="checkbox"/> Confined to bed <input type="checkbox"/> Unable to ambulate <input type="checkbox"/> Confined to home				
HOW LONG WILL THE PATIENT NEED THIS EQUIPMENT (BE SPECIFIC)				
IF THE EQUIPMENT IS FOR OXYGEN SUPPLIES, PLEASE PROVIDE THE FOLLOWING INFORMATION.				
FREQUENCY OF USE	MEDICAL NEED FOR THE EQUIPMENT	EXPECTED BENEFIT OF RECEIVING THE OXYGEN THERAPY		
IF THE EQUIPMENT IS FOR HOME BLOOD GLUCOSE MONITORING SYSTEM, PLEASE PROVIDE THE FOLLOWING INFORMATION.				
IS THE PATIENT TAKING INSULIN? <input type="checkbox"/> YES <input type="checkbox"/> NO	IF YES, FREQUENCY?	DEGREE OF DIABETIC CONTROL?		
KETOSIS? <input type="checkbox"/> YES <input type="checkbox"/> NO	INSULIN REACTIONS <input type="checkbox"/> YES <input type="checkbox"/> NO	IS PATIENT PREGNANT? <input type="checkbox"/> YES <input type="checkbox"/> NO		
ARE OTHER DIABETIC COMPLICATIONS PRESENT (BE SPECIFIC)				
PHYSICIAN'S NAME		ADDRESS	CITY	STATE      ZIP
PHYSICIAN'S PHONE NO.	PHYSICIAN'S SIGNATURE		DATE	
	X			



AUTHORITY NOTE: Promulgated in accordance with R.S. 23:1034.2.

HISTORICAL NOTE: Promulgated by the Department of Labor, Office of Workers' Compensation, LR 19:54 (January 1993), repromulgated LR 19:212 (February 1993), amended LR 20:1299 (November 1994).

**§4119. Maximum Allowance Schedules**

**A. Durable Medical Equipment**

State of Louisiana Office of Workers' Compensation Schedule of Maximum Allowances for Durable Medical Equipment				
HCPCS	Description	Purchase New	Purchase Used	Rental
E0100	Cane, adj/fixed, w/tip	\$26	\$21	\$7
E0105	Cane, quad/three prong	\$61	\$47	\$9
E0110	Crutches, forearm	\$96	\$72	\$17
E0111	Crutch forearm	\$56	\$43	\$11
E0112	Crutches underarm, wood, pair	\$46	\$35	\$10
E0113	Crutch underarm, wood, each	\$29	\$22	\$7
E0114	Crutches underarm, aluminum, pair	\$64	\$48	\$11
E0116	Crutch underarm, aluminum, each	\$38	\$29	\$8
E0117	Underarm springassist crutch	\$269	\$202	\$27
E0118	Crutch substitute	B.R.	B.R.	B.R.
E0130	Walker, rigid, adj/fixed hgt	\$87	\$68	\$18
E0135	Walker, folding, adj/fixed hgt	\$102	\$79	\$18
E0140	Walker w trunk support	\$434	\$326	\$43
E0141	Walker, wheeled, w/out seat	\$142	\$107	\$24
E0143	Folding walker, wheeled, w/out seat	\$148	\$111	\$23
E0144	Enclosed walker w rear seat	\$383	\$287	\$38
E0147	Walker, heavy duty, break sys	\$501	\$381	\$51
E0148	Heavyduty walker no wheels	\$153	\$115	\$15
E0149	Heavy duty wheeled walker	\$269	\$201	\$27
E0153	Platform attac, forearm crutch, ea	\$86	\$64	\$9
E0154	Platform attachment, walker, ea	\$87	\$66	\$1
E0155	Wheel attach, rigid pick-up walker	\$33	\$25	\$4
E0156	Seat attach, walker	\$46	\$35	\$5
E0157	Crutch attach, walker, ea	\$101	\$76	\$11
E0158	Leg extensions a walker	\$36	\$27	\$4
E0159	Brake for wheeled walker	\$22	\$16	\$2
E0160	Sitz bath, port, fits over seat	\$44	\$33	\$5
E0161	Sitz bath, port, fits over seat	\$48	\$36	\$5
E0162	Sitz bath chair	\$180	\$139	\$18
E0163	Commode chair, stat, w/fixed arms	\$125	\$98	\$26
E0165	Commode chair, stat, w/detach arms	\$195	\$146	\$19
E0166	Commode chair, mob, w/detach arms	\$327	\$245	\$33
E0167	Pail/pan use w/commode chair	\$13	\$9	\$2
E0168	Heavyduty/wide commode chair	\$211	\$158	\$21
E0170	Commode chair electric			\$224
E0171	Commode chair non-electric			\$40
E0172	Seat lift mechanism toilet	B.R.	B.R.	B.R.
E0175	Foot rest, use w/commode chair	\$69	\$51	\$7

State of Louisiana Office of Workers' Compensation Schedule of Maximum Allowances for Durable Medical Equipment				
HCPCS	Description	Purchase New	Purchase Used	Rental
E0181	Pres pad, alt w/pump, heavy duty	\$382	\$287	\$38
E0182	Pump alternating pressure pad	\$275	\$206	\$27
E0184	Dry pressure mattress	\$344	\$258	\$38
E0185	Gel pressure pad mattress	\$336	\$258	\$47
E0188	Synthetic sheepskin pad	\$37	\$28	\$4
E0189	Lambswool sheepskin, pad any size	\$73	\$54	\$8
E0190	Positioning cushion	B.R.	B.R.	B.R.
E0191	Heel/elbow protector, ea	\$12	\$9	\$2
E0193	Powered air flot bed	B.R.		\$1,371
E0194	Air fluidized bed	B.R.		\$4,016
E0196	Gel pressure mattress	\$341	\$256	\$34
E0197	Air pressure pad mattress	\$232	\$204	\$32
E0198	Water pressure pad mattress	\$232	\$176	\$24
E0199	Dry pressure pad mattress	\$34	\$25	\$3
E0200	Heat lamp, w/o stand	\$98	\$73	\$13
E0202	Phototherapy light w/photometer	\$1,043	\$782	\$105
E0203	Therapeutic lightbox tabletp	B.R.	B.R.	B.R.
E0205	Heat lamp, w/stand	\$240	\$180	\$26
E0210	Electric heat pad, std	\$39	\$29	\$4
E0215	Electric heat pad, moist	\$95	\$71	\$10
E0217	Water circ heat pad w pump	\$693	\$520	\$77
E0218	Water cicutating cold pad with pump	B.R.	B.R.	B.R.
E0221	Infared heating pad system	B.R.	B.R.	B.R.
E0225	Hydrocollator unit, includes pads	\$473	\$355	\$47
E0231	Non-contact wound warming device	B.R.	B.R.	B.R.
E0232	Warming cord for use with any wound warming device	B.R.	B.R.	B.R.
E0235	Paraffin bath unit, portable	\$213	\$160	\$21
E0236	Pump water circulating pad	\$546	\$410	\$55
E0239	Hydrocollator unit, portable	\$472	\$354	\$47
E0240	Bath/shower chair	B.R.		
E0241	Bath tub wall rail, ea	B.R.		
E0242	Bath tub rail, floor base	B.R.		
E0243	Toilet rail, ea	B.R.		
E0244	Raised toilet seat	B.R.		
E0245	Tub stool/bench	B.R.		
E0246	Transfer tub rail attachment	B.R.		
E0247	Trans bench w/wo comm open	B.R.		
E0248	HDtrans bench w/wo comm open	B.R.		
E0249	Pad water circulating heat unit	\$112	\$84	\$11
E0250	Hosp bed, fix hgt, rail/mattress	\$1,036	\$777	\$104
E0251	Hosp bed, fix hgt, rail/no mattress	\$853	\$640	\$85
E0255	Hosp bed, hi-lo, rail/mattress	\$1,356	\$1,017	\$136
E0256	Hosp bed, hi-lo, rail/no mattress	\$1,029	\$771	\$103
E0260	Hosp bed, semi-elect, rail/mattress	\$1,985	\$1,489	\$198
E0261	Hosp bed, semi-elect, rail/no mattress	\$1,690	\$1,268	\$169
E0265	Hosp bed, tot elect, rail/mattress	\$2,467	\$1,850	\$247
E0266	Hosp bed, tot elect, rail/no mattress	\$1,985	\$1,489	\$198

LABOR AND EMPLOYMENT

State of Louisiana Office of Workers' Compensation Schedule of Maximum Allowances for Durable Medical Equipment				
HCPCS	Description	Purchase New	Purchase Used	Rental
E0270	Hosp bed, inst type	B.R.		
E0271	Mattress, innerspring	\$237	\$182	\$24
E0272	Mattress, foam rubber	\$250	\$186	\$26
E0273	Bed board	B.R.		
E0274	Over-bed table	B.R.		
E0275	Bed pan, std, metal/plastic	\$16	\$12	\$2
E0276	Bed pan, fx, metal/plastic	\$19	\$14	\$2
E0277	Alternating pressure mattress	\$9,594	\$7,195	\$959
E0280	Bed cradle, any type	\$47	\$35	\$7
E0290	Hosp bed, fix hgt, w/o rails	\$922	\$692	\$92
E0291	Hosp bed, fix hgt, w/o rails	\$670	\$502	\$67
E0292	Hosp bed, hi-lo, w/o rails, w/mat	\$1,037	\$778	\$104
E0293	Hosp bed, hi-lo, w/o rails, w/o m	\$883	\$662	\$88
E0294	Hosp bed, semi-elect w/o rails	\$1,613	\$1,210	\$161
E0295	Hosp bed, semi-elect, w/o rails	\$1,572	\$1,179	\$157
E0296	Hosp bed, tot elect, w/out	\$2,026	\$1,520	\$203
E0297	Hosp bed, tot elect, w/out	\$1,736	\$1,302	\$174
E0300	Enclosed ped crib hosp grade	\$3,416	\$2,562	\$342
E0301	HD hosp bed, 350-600 lbs			\$326
E0302	Ex hd hosp bed > 600 lbs			\$861
E0303	Hosp bed hvy dty xtra wide			\$366
E0304	Hosp bed xtra hvy dty x wide			\$928
E0305	Bed side rails, half length	\$186	\$140	\$19
E0310	Bed side rails, full length	\$240	\$181	\$27
E0315	Bed access: boards/tables, any	B.R.		
E0316	Bed safety enclosure			\$254
E0325	Urinal; male, jug-type	\$14	\$11	\$3
E0326	Urinal; female, jug-type	\$13	\$10	\$3
E0328	Ped hospital bed, manual	B.R.	B.R.	B.R.
E0329	Ped hospital bed semi/elect	B.R.	B.R.	B.R.
E0350	Control unit bowel system	B.R.	B.R.	B.R.
E0352	Disposable pack w/bowel syst	B.R.	B.R.	B.R.
E0370	Air elevator for heel	B.R.	B.R.	B.R.
E0371	Nonpower mattress overlay			\$535
E0372	Powered air mattress overlay			\$649
E0373	Nonpowered pressure mattress			\$740
E0424	Stat comp gas O2 system, rental	\$455		
E0425	Stat comp gas O2 system, purchase	\$4,550	\$3,413	
E0430	Port gas O2 system, purchase	\$2,150	\$1,613	
E0431	Port gas O2 system, rental			\$215
E0433	Portable liquid oxygen sys			\$67
E0434	Port liquid O2 system, rental			\$223
E0435	Port liquid O2 system, purchase	\$2,230	\$1,673	
E0439	Stat liquid O2 system, rental			\$455
E0440	Stat liquid O2 system, purchase	\$4,550	\$3,413	
E0441	O2 contents, gaseous, per unit	\$20		
E0442	O2 contents, liquid, per unit	B.R.		
E0443	Port O2 contents, gaseous, unit	\$10		

State of Louisiana Office of Workers' Compensation Schedule of Maximum Allowances for Durable Medical Equipment				
HCPCS	Description	Purchase New	Purchase Used	Rental
E0444	Port O2 contents, liquid, unit	B.R.		
E0445	Oximeter non-invasive	B.R.		
E0446	Topical Ox Deliver sys, nos	B.R.		
E0450	Volume ventilator; stat/portable	B.R.	B.R.	\$1,750
E0455	O2 tent, excl croup/ped tents	B.R.		
E0457	Chest shell (cuirass)	\$721	\$540	\$72
E0459	Chest wrap	\$534	\$400	\$53
E0460	Neg pressure vent; port/statonary	\$9,053	\$6,790	\$905
E0461	Vol control vent noninv int			\$1,333
E0462	Rocking bed w//w/o side rails	\$3,057	\$2,293	\$306
E0463	Press supp vent invasive int			\$1,964
E0464	Press supp vent noninv int			\$2,132
E0470	RAD w/o backup non-inv intrfc			\$309
E0471	RAD w/backup non inv intrfc			\$773
E0472	RAD w backup invasive intrfc			\$773
E0480	Percussor, elect/pneum, home mod	\$670	\$503	\$67
E0481	Intrpulumry percuss vent sys	B.R.	B.R.	B.R.
E0482	Cough stimulating device			\$600
E0483	Chest compression gen system			\$1,486
E0484	Non-elec oscillatory pep dvc	\$52	\$39	\$5
E0485	Oral device/appliance prefab	B.R.	B.R.	B.R.
E0486	Oral device/appliance cusfab	B.R.	B.R.	B.R.
E0487	Electronic spirometer	B.R.	B.R.	B.R.
E0500	IPPB machine, w/built-in nebuliz	\$1,152	\$864	\$115
E0550	Humidifier, extensive sup humid	\$526	\$394	\$53
E0555	Humidifier, glass/autoclav plast	B.R.		
E0560	Humidifier, supplemental humidi	\$212	\$159	\$22
E0561	Humidifier nonheated w PAP	\$129	\$97	\$13
E0562	Humidifier heated used w PAP	\$363	\$272	\$36
E0565	Compressor, air power source	\$640	\$480	\$64
E0570	Nebulizer, w/compressor	\$207	\$155	\$21
E0572	Aerosol compressor adjust pr			\$53
E0574	Ultrasonic generator w svneb			\$56
E0575	Nebulizer; ultrasonic	\$1,078	\$809	\$108
E0580	Nebulizer, glass/autoclav plast	\$161	\$121	\$16
E0585	Nebulizer, w/compressor and heater	\$433	\$325	\$43
E0600	Suction pump, home model, port	\$491	\$368	\$50
E0601	Cont airway pressure (cpap) dev	\$1,172	\$879	\$117
E0602	Manual breast pump	\$41	\$31	\$4
E0603	Electric breast pump	B.R.	B.R.	B.R.
E0604	Hosp grade elec breast pump	B.R.	B.R.	B.R.
E0605	Vaporizer, room type	\$29	\$23	\$3

State of Louisiana Office of Workers' Compensation Schedule of Maximum Allowances for Durable Medical Equipment				
HPCPS	Description	Purchase New	Purchase Used	Rental
E0606	Postural drainage board	\$241	\$180	\$24
E0607	Home blood glucose monitor	\$261	\$205	\$30
E0610	Pacemaker monitor, self-contained	\$289	\$217	\$29
E0615	Pacemaker monitor, self-contained	\$502	\$377	\$61
E0616	Cardiac event recorder	B.R.		
E0617	Automatic ext defibrillator			\$471
E0618	Apnea monitor			\$391
E0619	Apnea monitor w recorder	B.R.	B.R.	B.R.
E0620	Cap bld skin piercing laser	\$1,221	\$916	\$28
E0621	Sling/seat, pat lift, canvas/nylon	\$118	\$89	\$11
E0625	Patient lift, kartop, bathroom	B.R.	B.R.	B.R.
E0627	Seat lift mech in comb lift-chair	\$408	\$306	\$41
E0628	Sep seat lift mech	\$408	\$306	\$41
E0629	Sep seat lift mech	\$408	\$306	\$41
E0630	Patient lift, hydraulic	\$1,257	\$943	\$126
E0635	Patient lift, electric	\$1,608	\$1,206	\$161
E0636	PT support and positioning sys			\$1,473
E0637	Combination sit to stand sys	B.R.	B.R.	B.R.
E0638	Standing frame sys	B.R.	B.R.	B.R.
E0639	Moveable patient lift system	B.R.	B.R.	B.R.
E0640	Fixed patient lift system	B.R.	B.R.	B.R.
E0641	Multi-position std fram sys	B.R.	B.R.	B.R.
E0642	Dynamic standing frame	B.R.	B.R.	B.R.
E0650	Pneumatic compress, non-seg home	\$889	\$667	\$113
E0651	Pneumatic compress, seg home mod	\$1,133	\$850	\$116
E0652	Pneumatic compress, seg home mod	\$6,543	\$4,903	\$647
E0655	Pneum appl use w/comp, half arm	\$152	\$114	\$16
E0656	Segmental pneumatic trunk	\$807	\$605	\$81
E0657	Segmental pneumatic chest	\$758	\$568	\$76
E0660	Pneum appl use w/comp, full leg	\$199	\$149	\$28
E0665	Pneum appl use w/comp, full arm	\$172	\$129	\$17
E0666	Pneum appl use w/comp, half leg	\$176	\$132	\$25
E0667	Pneum appl use w/seg comp, leg	\$464	\$348	\$45
E0668	Pneum appl use w/seg comp, arm	\$545	\$409	\$54
E0669	Segmental pneumatic appliance	\$256	\$192	\$26
E0671	Pressure pneum appl full leg	\$580	\$435	\$58
E0672	Pressure pneum appl full arm	\$451	\$338	\$45
E0673	Pressure pneum appl half leg	\$374	\$281	\$37
E0675	Pneumatic compression device			\$537
E0676	Inter limb compress dev NOS	B.R.	B.R.	B.R.
E0691	Uvl pnl 2 sq ft or less	\$1,255	\$941	\$125
E0692	Uvl sys panel 4 ft	\$1,576	\$1,182	\$158
E0693	Uvl sys panel 6 ft	\$1,576	\$1,182	\$158
E0694	Uvl md cabinet sys 6 ft	\$6,182	\$4,637	\$618
E0700	Safety equipment	B.R.		
E0705	Transfer device	\$77	\$56	\$8

State of Louisiana Office of Workers' Compensation Schedule of Maximum Allowances for Durable Medical Equipment				
HPCPS	Description	Purchase New	Purchase Used	Rental
E0710	Restraints, any type	B.R.		
E0720	Tens, two lead, loc stimulation	\$593	\$445	\$59
E0730	Tens, 4 lead, lrg area/mult nerve	\$593	\$445	\$59
E0731	Form fit garment del tens/nmes	\$440		
E0740	Incontinence treatment systm	\$730	\$548	\$73
E0744	Neuromusc stimulator scoliosis	\$1,052	\$789	\$105
E0745	Neuromusc stimulator, elect shock	\$939	\$704	\$94
E0746	Electromyography, biofeedback dev	B.R.		
E0747	Osteogenesis stimulator (non-inv)	\$4,353	\$3,234	\$433
E0748	Elec osteogen stim spinal	\$5,433	\$4,072	\$543
E0749	Osteogenesis stimulator (surg)	\$3,161	\$2,371	\$316
E0755	Elect salivary reflex stimulator	B.R.	B.R.	B.R.
E0760	Osteogen ultrasound stimltor	\$4,515	\$3,386	\$451
E0761	Nontherm electromgntc device	B.R.	B.R.	B.R.
E0762	Trans elec jt stim dev sys	\$1,535	\$1,152	\$154
E0764	Functional neuromuscularstim	\$15,453	\$11,590	\$1,545
E0765	Nerve stimulator for tx n and v	\$117	\$88	\$12
E0769	Electric wound treatment dev	B.R.	B.R.	B.R.
E0770	Functional electric stim NOS	B.R.	B.R.	B.R.
E0776	IV pole	\$150	\$110	\$23
E0779	Amb infusion pump mechanical			\$23
E0780	Mech amb infusion pump <8hrs	\$14		
E0781	Ambulatory infusion pump, sgl/mul	\$3,304	\$2,478	\$330
E0782	Infusion pump, implantable	\$4,258	\$3,193	\$426
E0783	Programmable infusion pump	\$11,432	\$8,574	\$1,143
E0784	Ext amb infusn pump insulin			\$583
E0785	Replacement impl pump cathet	\$660		
E0786	Implantable pump replacement	\$11,151	\$8,363	\$1,115
E0791	Parent infus pump, stationary	\$3,317	\$2,488	\$332
E0830	Ambulatory traction device	B.R.	B.R.	B.R.
E0840	Traction frame, att, simp cerv tr	\$80	\$60	\$17
E0849	Cervical pneum trac equip	\$720	\$540	\$72
E0850	Traction stand, free, simp cervic	\$110	\$83	\$16
E0855	Cervical traction equipment	\$702	\$526	\$70
E0856	Cervic collar w air bladder	\$215	\$161	\$22
E0860	Traction equip, ovrdoor, cervical	\$58	\$44	\$12
E0870	Traction frame, att, simple extrm	\$122	\$92	\$16

LABOR AND EMPLOYMENT

State of Louisiana Office of Workers' Compensation Schedule of Maximum Allowances for Durable Medical Equipment				
HCPCS	Description	Purchase New	Purchase Used	Rental
E0880	Traction stand, free, simple extr	\$132	\$100	\$22
E0890	Traction frame, footboard, pelvic	\$149	\$120	\$41
E0900	Traction stand, free, pelvic trac	\$158	\$119	\$34
E0910	Trapeze bars, att to bed, w/grab	\$232	\$174	\$23
E0911	HD trapeze bar attach to bed			\$60
E0912	HD trapeze bar free standing			\$138
E0920	Fx frame, att to bed, inc. weights	\$487	\$365	\$49
E0930	Fx frame, free, includes weights	\$479	\$360	\$48
E0935	Passive motion exercise device	\$6,134	\$4,601	\$613
E0936	CPM device, other than knee	B.R.	B.R.	B.R.
E0940	Trapeze bar, free, w/grab bar	\$365	\$274	\$36
E0941	Gravity asst traction device, any	\$487	\$365	\$49
E0942	Cervical head harness/halter	\$21	\$16	\$2
E0944	Pelvic belt/harness/boot	\$48	\$36	\$5
E0945	Extrm belt/harness	\$47	\$36	\$5
E0946	Fx frame, dual w/cross bars, att	\$621	\$465	\$62
E0947	Fx frame, attachments pelv tract	\$636	\$477	\$66
E0948	Fx frame, attachments cerv tract	\$615	\$434	\$62
E0950	Tray	\$109	\$82	\$12
E0951	Loop heel, ea	\$20	\$15	\$2
E0952	Loop toe, ea	\$23	\$17	\$2
E0955	Cushioned headrest	\$282	\$212	\$28
E0956	W/c lateral trunk/hip suppor	\$138	\$103	\$14
E0957	W/c medial thigh support	\$193	\$144	\$19
E0958	Wheelchair attachment	\$539	\$404	\$54
E0959	Amputee adapter	\$109	\$83	\$11
E0960	W/c shoulder harness/straps	\$127	\$95	\$13
E0961	Brake extension, wheelchair	\$37	\$28	\$4
E0966	Hook on head rest extension	\$86	\$64	\$9
E0967	Wheelchair hand rims	\$163	\$122	\$17
E0968	Commode seat, wheelchair	\$188	\$141	\$19
E0969	Narrowing device, wheelchair	\$164	\$123	\$16
E0970	No.2 footplates, exc elev leg rst	\$51	\$38	\$5
E0971	Anti-tipping device wheelchairs	\$81	\$61	\$9
E0973	Adj hgt detach arms, full length	\$121	\$90	\$11
E0974	"Grade-aid"	\$83	\$62	\$9
E0978	Belt, safety w/airplane buckle	\$49	\$37	\$5
E0980	Safety vest, wheelchair	\$34.67	\$25.87	\$3.45
E0981	Seat upholstery, replacement	\$66	\$50	\$7
E0982	Back upholstery, replacement	\$72	\$54	\$7
E0983	Add pwr joystick			\$349
E0984	Add pwr tiller	\$2,668	\$2,059	\$248
E0985	W/c seat lift mechanism	\$283	\$212	\$28
E0986	Man w/c push-rim pow assist	\$6,792	\$5,094	\$679
E0988	Lever-activated wheel drive			\$418
E0990	Elevating leg rest, ea	\$145	\$113	\$16

State of Louisiana Office of Workers' Compensation Schedule of Maximum Allowances for Durable Medical Equipment				
HCPCS	Description	Purchase New	Purchase Used	Rental
E0992	Solid seat insert	121	88.08	11.42
E0994	Arm rest, ea	\$20	\$15	\$2
E0995	Calf rest, ea	\$39	\$28	\$4
E1002	Pwr seat tilt	\$5,660	\$4,245	\$566
E1003	Pwr seat recline	\$6,132	\$4,599	\$613
E1004	Pwr seat recline mech	\$5,799	\$5,099	\$680
E1005	Pwr seat recline pwr	\$7,359	\$5,520	\$736
E1006	Pwr seat combo w/o shear	\$9,015	\$6,761	\$901
E1007	Pwr seat combo w/shear	\$12,206	\$9,154	\$1,221
E1008	Pwr seat combo pwr shear	\$12,207	\$9,155	\$1,221
E1009	Add mech leg elevation	B.R.	B.R.	B.R.
E1010	Add pwr leg elevation	\$1,597	\$1,198	\$160
E1011	Ped wc modify width adjustm	B.R.	B.R.	B.R.
E1014	Reclining back add ped w/c	\$510	\$382	\$51
E1015	Shock absorber for man w/c	\$160	\$120	\$16
E1016	Shock absorber for power w/c	\$183	\$138	\$18
E1017	HD shck absbr for hd man wc	B.R.	B.R.	B.R.
E1018	HD shck absbr for hd powwc	B.R.	B.R.	B.R.
E1020	Residual limb support system	\$340	\$255	\$34
E1028	W/c manual swingaway	\$288	\$216	\$7
E1029	W/c vent tray fixed	\$516	\$387	\$52
E1030	W/c vent tray gimbaled	\$1,627	\$1,220	\$163
E1031	Rollabout chair, w/castors 5">	\$530	\$397	\$53
E1035	Patient transfer system <301			\$856
E1036	Patient transfer system >300			\$1,200
E1037	Transport chair, ped size			\$151
E1038	Transport chair pt wt<=300lb			\$25
E1039	Transport chair pt wt >300lb			\$48
E1050	Fully-recl wheelchair, fixed arms	\$1,257	\$943	\$126
E1060	Fully-recl wheelchair, detach arms	\$1,352	\$1,014	\$135
E1070	Fully-recl wheelchair, detach arm	\$1,352	\$1,014	\$135
E1083	Hemi-wheelchair, fixed arms	\$972	\$729	\$97
E1084	Hemi-wheelchair, detach arms	\$1,132	\$849	\$113
E1085	Hemi-wheelchair, fixed arms	\$854	\$641	\$85
E1086	Hemi-wheelchair detach arms	\$1,037	\$778	\$104
E1087	Hi strength lightwgt wheelchair	\$1,344	\$1,008	\$134
E1088	Hi strength lightwgt wheelchair	\$1,582	\$1,186	\$158
E1089	Hi strength lightwgt wheelchair	\$1,261	\$946	\$126
E1090	Hi strength lightwgt wheelchair	\$1,428	\$1,071	\$143
E1092	Wide heavy duty wheel chair	\$1,428	\$1,071	\$143
E1093	Wide heavy duty wheelchair	\$1,159	\$870	\$116
E1100	Semi-reclining wheelchair	\$1,157	\$867	\$116
E1110	Semi-reclining wheelchair	\$1,066	\$800	\$107
E1130	Standard wheelchair, fixed arms	\$576	\$432	\$58
E1140	Wheelchair, detachable arms	\$834	\$626	\$83
E1150	Wheelchair, detachable arms	\$914	\$686	\$91

State of Louisiana Office of Workers' Compensation Schedule of Maximum Allowances for Durable Medical Equipment				
HCPCS	Description	Purchase New	Purchase Used	Rental
E1160	Wheelchair, fix full length arms	\$763	\$572	\$76
E1161	Manual adult wc w tiltinspac	\$3,304	\$2,478	\$330
E1170	Amputee wheelchair, fix arms	\$937	\$703	\$94
E1171	Amputee wheelchair, fix arms	\$989	\$742	\$99
E1172	Amputee wheelchair, detach arms	\$1,209	\$907	\$121
E1180	Amputee wheelchair, detach arms	\$1,063	\$797	\$106
E1190	Amputee wheelchair, detach arms	\$1,254	\$940	\$125
E1195	Heavy duty wheelchair	\$1,428	\$1,071	\$143
E1200	Amputee wheelchair	\$1,031	\$774	\$103
E1220	Wheelchair; specially sized	B.R.		
E1221	Wheelchair w/fixd arm, footrests	\$499	\$374	\$50
E1222	Wheelchair w/fixd arm, legrests	\$763	\$572	\$76
E1223	Wheelchair w/det arms, footrests	\$834	\$626	\$83
E1224	Wheelchair w/det arms, legrests	\$1,002	\$751	\$100
E1225	Wheelchair; semi-rec back custom	\$502	\$377	\$50
E1226	Wheelchair; full rec back custom	\$693	\$520	\$69
E1227	Special height arms wheelchair	\$291	\$218	\$29
E1228	Special back height wheelchair	\$318	\$239	\$32
E1229	Pediatric wheelchair NOS	B.R.	B.R.	B.R.
E1230	Power operated vehicle	\$2,479	\$2,208	\$248
E1231	Rigid ped w/c tilt-in-space	B.R.		
E1232	Folding ped wc tilt-in-space	\$2,986	\$2,240	\$299
E1233	Rig ped wc tltnspc w/o seat	\$3,094	\$2,320	\$309
E1234	Fld ped wc tltnspc w/o seat	\$2,694	\$2,020	\$269
E1235	Rigid ped wc adjustable	\$2,594	\$1,945	\$259
E1236	Folding ped wc adjustable	\$2,288	\$1,716	\$229
E1237	Rgd ped wc adjstabl w/o seat	\$2,308	\$1,731	\$231
E1238	Fld ped wc adjstabl w/o seat	\$2,288	\$1,716	\$229
E1239	Ped power wheelchair NOS	B.R.	B.R.	B.R.
E1240	Lightweight wheelchair	\$1,081	\$811	\$108
E1250	Lightweight wheelchair	\$938	\$704	\$94
E1260	Lightweight wheelchair	\$1,150	\$863	\$115
E1270	Lightweight wheelchair	\$953	\$715	\$95
E1280	Heavy duty wheelchair	\$1,377	\$1,033	\$138
E1285	Heavy duty wheelchair	\$1,265	\$949	\$127
E1290	Heavy duty wheelchair	\$1,313	\$985	\$131
E1295	Heavy duty wheelchair	\$1,274	\$956	\$127
E1296	Special wheelchair seat	\$607	\$455	\$62
E1297	Special wheelchair seat	\$129	\$97	\$14
E1298	Special wheelchair seat	\$523	\$392	\$54
E1300	Whirlpool, portable (overtub)	B.R.		
E1310	Whirlpool, non-port (built-in)	\$2,650	\$1,988	\$227
E1353	Regulator	B.R.		
E1354	Wheeled cart, port cyl/conc	B.R.	B.R.	B.R.
E1355	Stand/rack	B.R.	B.R.	B.R.
E1356	Batt pack/cart, port conc	B.R.	B.R.	B.R.
E1357	Battery charger, port conc	B.R.	B.R.	B.R.
E1358	DC power adapter, port conc	B.R.	B.R.	B.R.

State of Louisiana Office of Workers' Compensation Schedule of Maximum Allowances for Durable Medical Equipment				
HCPCS	Description	Purchase New	Purchase Used	Rental
E1372	Immersion ext heater nebulizer	\$201	\$149	\$29
E1390	Oxygen concentrator			\$229
E1391	Oxygen concentrator, dual			\$229
E1392	Portable oxygen concentrator			\$67
E1399	Durable medical equipment, misc	B.R.		
E1405	O2 and water vapor enriching system	B.R.		
E1406	O2 and water vapor enriching system	B.R.		
E1500	Centrifuge	B.R.	B.R.	B.R.
E1510	Kidney, dialysate delivery system	B.R.		
E1520	Heparin infusion pump dialysis	B.R.		
E1530	Air bubble detector dialysis	B.R.		
E1540	Pressure alarm dialysis	B.R.		
E1550	Bath conductivity meter dialysis	B.R.		
E1560	Blood leak detector dialysis	B.R.		
E1570	Adj chair, esrd patients	B.R.		
E1575	Transduc protectrs/fluid barriers	B.R.		
E1580	Unipunct control system dialysis	B.R.		
E1590	Hemodialysis machine	B.R.		
E1592	Auto interm perit dialysis system	B.R.		
E1594	Cycler dialysis mach perit dial	B.R.		
E1600	Delv/install charges dialysis equ	B.R.		
E1610	Rev osmosis water purif system	B.R.		
E1615	Deionizer water purif system	B.R.		
E1620	Blood pump dialysis	B.R.		
E1625	Water softening system	B.R.		
E1630	Recipro peritoneal dialysis sys	B.R.		
E1632	Wearable artificial kidney	B.R.		
E1634	Peritoneal dialysis clamp	B.R.	B.R.	B.R.
E1635	Compact travel hemodialyzer sys	B.R.		
E1636	Sorbent cartridges, per case	B.R.		
E1637	Hemostats for dialysis, each	B.R.	B.R.	B.R.
E1639	Dialysis scale	B.R.	B.R.	B.R.
E1699	Dialysis equip, uns, by report	B.R.		
E1700	Jaw motion rehabilitation system	\$362	\$271	\$35
E1701	Repl cushions jaw motion rehab	\$13	\$10	\$1
E1702	Repl Measuring Scales Jaw Motion	\$24	\$18	\$2

AUTHORITY NOTE: Promulgated in accordance with R.S. 23:1034.2.

HISTORICAL NOTE: Promulgated by the Department of Labor, Office of Workers' Compensation, LR 19:54 (January 1993), repromulgated LR 19:212 (February 1993), amended LR 20:1299 (November 1994), amended by the Workforce Commission, Office

of Workers' Compensation, LR 39:1841 (July 2013), LR 40:375 (February 2014).

§§4121.-4137. **Reserved.**

## Chapter 43. Prosthetic and Orthopedic Equipment

Editor's Note: Other Sections applying to this Chapter can be found in Chapter 51.

§§4301-4309. **Reserved.**

### §4311. Covered Services

#### A. Prosthetic/Orthotic Appliances

1. The carrier/self-insured employer will pay only for those orthotic or prosthetic devices prescribed by an authorized physician for a recognized occupational injury or illness. The device must be described in commonly recognized language in accordance with the Schedule of Maximum Allowances included in this document.

2. Repairs and modifications to achieve satisfactory adjustment of an appliance shall be made within 60 days of initial fitting without additional charge by the supplier of the orthotic or prosthetic device. The provider should attach a signed statement from the claimant acknowledging receipt of the item whenever submitting invoices to the carrier/self-insured employer for prosthetic appliances.

3. Neither a myoelectric (bionic) prosthetic appliance or a cosmetic prosthetic appliance will be approved unless the standard, functional version of the prosthesis has been used on a 6-month trial basis. Both versions will not be reimbursed simultaneously.

4. Appliances purchased in connection with a compensable injury may be replaced if medically necessary.

NOTE: Please consult the Vision Care Services Fee Schedule for information concerning the billing of artificial eyes. A separate fee schedule is also published with billing instructions and rates for durable medical equipment and supplies as well as hearing aid equipment and services.

B. Braces and Other Nonfitted Items. Braces and other items which are not custom fitted, such as collars and prosthetic supplies that are prescribed by the authorized physician, are reimbursable without prior authorization if the provider's usual and customary charge is \$50 or less. Prior authorization is also unnecessary for those braces and back supports provided for a claimant's hospital discharge if the charge does not exceed \$150. Please indicate "Hospital

Discharge" in the "Remarks" section of the invoice whenever appropriate.

C. Orthopedic Shoes. The carrier/self-insured employer will pay for orthopedic or specially constructed shoes following foot injuries only when stock shoes cannot be used or modified at a lesser cost.

AUTHORITY NOTE: Promulgated in accordance with R.S. 23:1034.2.

HISTORICAL NOTE: Promulgated by the Department of Labor, Office of Workers' Compensation, LR 19:54 (January 1993), repromulgated LR 19:212 (February 1993), amended LR 20:1299 (November 1994).

### §4313. Nonlisted Items and Individual Consideration

A. Occasionally, there may be a workers' compensation claim where the HCPCS code either does not appear on the Schedule of Maximum Allowances or is designated as "By Report (BR)." In these instances where medical necessity has been documented, the carrier/self-insured employer should contact three prosthetic and orthotic equipment suppliers in the geographic area from which the claim originated and obtain charge information for the specific HCPCS code billed. The carrier will use the average of the three responses as the maximum allowance for the specific HCPCS code. This procedure may be repeated when necessary for other codes which fall into this category.

AUTHORITY NOTE: Promulgated in accordance with R.S. 23:1034.2.

HISTORICAL NOTE: Promulgated by the Department of Labor, Office of Workers' Compensation, LR 19:54 (January 1993), repromulgated LR 19:212 (February 1993), amended LR 20:1299 (November 1994).

### §4315. Noncovered Services

A. In general, only those equipment items listed in the section of this manual entitled "Maximum Allowances" will be reimbursed. The use of otherwise unlisted HCPCS codes may be covered when medical necessity is documented.

AUTHORITY NOTE: Promulgated in accordance with R.S. 23:1034.2.

HISTORICAL NOTE: Promulgated by the Department of Labor, Office of Workers' Compensation, LR 19:54 (January 1993), repromulgated LR 19:212 (February 1993), amended LR 20:1299 (November 1994).

### §4317. Billing Instructions

A. In addition to the HCFA 1500 Form, the completed Medical Certification Form (LDOL-WC-3002) must be submitted for all initial claims either rental or purchase.

Title 40, Part I

B. DME 3002 Form

		<b>DURABLE MEDICAL EQUIPMENT CERTIFICATION</b>		
<b>THIS FORM MUST BE COMPLETED BY THE PHYSICIAN PRESCRIBING THE EQUIPMENT AND ATTACHED TO THE CLAIM FILED BY THE SUPPLIER</b>				
PATIENT'S NAME		AGE	CONTRACT NO.	
EQUIPMENT PRESCRIBED			DATE PRESCRIBED	
DIAGNOSIS				
LIMITATIONS (Check all conditions applicable)				
<input type="checkbox"/> Weakness of arm(s) <input type="checkbox"/> Confined to chair <input type="checkbox"/> Other <input type="checkbox"/> Weakness of leg(s) <input type="checkbox"/> Confined to bed <input type="checkbox"/> Unable to ambulate <input type="checkbox"/> Confined to home				
HOW LONG WILL THE PATIENT NEED THIS EQUIPMENT (BE SPECIFIC)				
IF THE EQUIPMENT IS FOR OXYGEN SUPPLIES, PLEASE PROVIDE THE FOLLOWING INFORMATION.				
FREQUENCY OF USE		MEDICAL NEED FOR THE EQUIPMENT		EXPECTED BENEFIT OF RECEIVING THE OXYGEN THERAPY
IF THE EQUIPMENT IS FOR HOME BLOOD GLUCOSE MONITORING SYSTEM, PLEASE PROVIDE THE FOLLOWING INFORMATION.				
IS THE PATIENT TAKING INSULIN? <input type="checkbox"/> YES <input type="checkbox"/> NO		IF YES, FREQUENCY?		DEGREE OF DIABETIC CONTROL?
KETOISIS? <input type="checkbox"/> YES <input type="checkbox"/> NO		INSULIN REACTIONS <input type="checkbox"/> YES <input type="checkbox"/> NO		IS PATIENT PREGNANT? <input type="checkbox"/> YES <input type="checkbox"/> NO
ARE OTHER DIABETIC COMPLICATIONS PRESENT (BE SPECIFIC)				
PHYSICIAN'S NAME		ADDRESS	CITY	STATE      ZIP
PHYSICIAN'S PHONE NO.		PHYSICIAN'S SIGNATURE		DATE
		X		

AUTHORITY NOTE: Promulgated in accordance with R.S. 23:1034.2.

HISTORICAL NOTE: Promulgated by the Department of Labor, Office of Workers' Compensation, LR 19:54 (January 1993),

repromulgated LR 19:212 (February 1993), amended LR 20:1299 (November 1994).

LABOR AND EMPLOYMENT

§§4319-4337. Reserved.

§4339. Schedule of Maximum Allowances and Procedural Codes

A. This maximum allowable reimbursement schedule provides the basis for identification of prosthetic and orthopedic equipment reimbursable to providers. The coding system used is the health care financing administration common procedure coding system (HCPCS). No other coding methodology will be accepted for this program. Invoices submitted to the carrier/self-insured employer should be billed at the providers usual and customary rate, not the maximum allowable charge designated in this fee schedule. Reimbursement is limited to the least of:

1. the provider's usual and customary charge; or
2. a previously negotiated amount by the provider and carrier/self-insured employer; or
3. the allowable reimbursement schedule.

B. Prosthetic and Orthopedic Equipment

Office of Workers' Compensation Schedule of Maximum Allowances for Prosthetic and Orthopedic Equipment		
HCPCS	Description	Purchase New
L0112	Cranial cervical orthosis	\$2,007
L0113	Cranial cervical torticollis	\$410
L0120	Cerv, flex, non-adj (foam collar)	\$24
L0130	Cerv, flex, thermoplastic collar	\$149
L0140	Cerv, semi-rigid, adj	\$60
L0150	Cerv, semi-rigid, adj chin cup	\$99
L0160	Cerv, semi-rigid, occ/mand supp	\$191
L0170	Cerv, collar, molded to pat model	\$626
L0172	Cerv, collar, semi-rigid thermopl	\$129
L0174	Cerv, collar, semi-rigid, thermop	\$251
L0180	Cerv, mult post collar, occ/mandi	\$377
L0190	Cerv, mult post collar, occ/mandi	\$488
L0200	Cerv, mult post collar, occ/mandi	\$545
L0220	Thoracic, rib belt, custom made	\$149
L0430	TLSO, a-p-l rotary control	\$1,493.73
L0450	TLSO flex prefab thoracic	\$261
L0452	TLSO flex custom fab thoraci	B.R.
L0456	TLSO flex prefab	\$1,426
L0458	TLSO 2Mod symphis-xipho pre	\$1,279
L0460	TLSO2Mod symphysis-stern pre	\$1,440
L0462	TLSO 3Mod sacro-scap pre	\$1,791
L0464	TLSO 4Mod sacro-scap pre	\$2,132
L0466	TLSO rigid frame pre soft ap	\$561
L0468	TLSO rigid frame prefab pelv	\$688
L0470	TLSO rigid frame pre subclav	\$957
L0472	TLSO rigid frame hyperex pre	\$607
L0480	TLSO rigid plastic custom fa	\$2,138
L0482	TLSO rigid lined custom fab	\$2,328
L0484	TLSO rigid plastic cust fab	\$2,668
L0486	TLSO rigidlined cust fab two	\$2,830
L0488	TLSO rigid lined pre one pie	\$1,440
L0490	TLSO rigid plastic pre one	\$406
L0491	TLSO 2 piece rigid shell	\$1,102
L0492	TLSO 3 piece rigid shell	\$715
L0621	SIO flex pelvisacral prefab	\$138
L0622	SIO flex pelvisacral custom	\$388
L0623	SIO panel prefab	B.R.
L0624	SIO panel custom	B.R.
L0625	LO flexibl L1-below L5 pre	\$79
L0626	LO sag stays/panels pre-fab	\$112

Office of Workers' Compensation Schedule of Maximum Allowances for Prosthetic and Orthopedic Equipment		
HCPCS	Description	Purchase New
L0627	LO sagitt rigid panel prefab	\$590
L0628	LO flex w/o rigid stays pre	\$120
L0629	LSO flex w/rigid stays cust	B.R.
L0630	LSO post rigid panel pre	\$232
L0631	LSO sag-coro rigid frame pre	\$1,473
L0632	LSO sag rigid frame cust	B.R.
L0633	LSO flexion control prefab	\$411
L0634	LSO flexion control custom	B.R.
L0635	LSO sagitt rigid panel prefab	\$1,437
L0636	LSO sagittal rigid panel cus	\$2,127
L0637	LSO sag-coronal panel prefab	\$1,683
L0638	LSO sag-coronal panel custom	\$1,892
L0639	LSO s/c shell/panel prefab	\$1,683
L0640	LSO s/c shell/panel custom	\$1,501
L0700	CTLSO	\$1,878
L0710	CTLSO, a-p-l-control, molded	\$2,023
L0810	Halo proc, cerv halo jacket	\$2,506
L0820	Halo proc, cerv halo plaster body	\$2,114
L0830	Halo proc, cerv halo Milwaukee type	\$3,387
L0859	MRI compatible system	\$1,829
L0861	Halo repl liner/interface	\$309
L0970	TLSO, corset front	\$133
L0972	LSO, corset front	\$122
L0974	TLSO, full corset	\$184
L0976	LSO, full corset	\$172
L0978	Axillary crutch extension	\$180
L0980	Peroneal straps, pair	\$21
L0982	Stocking supp grips, set four	\$20
L0984	Protective body sock, each	\$56
L0999	Add to spinal orthosis NOS	B.R.
L1000	CTLSO (Milwaukee), inclusive	\$2,020
L1001	CTLSO infant immobilizer	B.R.
L1005	Tension based scoliosis orth	\$4,590.55
L1010	Add to CTLSO	\$72
L1020	Add to CTLSO, kyphosis pad	\$100
L1025	Add to CTLSO, kyphosis pad, floatin	\$114
L1030	Add to CTLSO, lumbar	\$78
L1040	Add to CTLSO, lumbar	\$81
L1050	Add to CTLSO, sternal pad	\$98
L1060	Add to CTLSO, thoracic pad	\$95
L1070	Add to CTLSO, trapezius	\$93
L1080	Add to CTLSO, outrigger	\$52
L1085	Add to CTLSO, outrigger	\$158
L1090	Add to CTLSO, lumbar sling	\$94
L1100	Add to CTLSO, ring flange	\$162
L1110	Add to CTLSO, ring flange	\$236
L1120	Add to CTLSO, cover	\$43
L1200	TLSO, inclusive furnishing	\$1,649
L1210	Add to TLSO, lat thoracic ext	\$239
L1220	Add to TLSO, ant thoracic ext	\$232
L1230	Add to TLSO, milw type superstruc	\$520
L1240	Add to TLSO, lumb derotation pad	\$77
L1250	Add to TLSO, ant asis pad	\$74
L1260	Add to TLSO, ant thor derot pad	\$75
L1270	Add to TLSO, abdominal pad	\$72
L1280	Add to TLSO, rib gusset	\$79
L1290	Add to TLSO, lat troch pad	\$72
L1300	Oth scolio proc, body jacket	\$1,762
L1310	Oth scolio proc, postop body jack	\$1,697
L1499	Unlisted proc spinal orthosis	B.R.
L1600	HO, abd cont hip jnts, flex	\$157
L1610	HO, abd cont hip jnts, flex, frej	\$42
L1620	HO, abd cont hip jnts, flex, pavl	\$123
L1630	HO, abd cont hip jnts, semi-flex	\$155
L1640	HO, abd cont hip jnts, stat, pelv	\$486



Office of Workers' Compensation Schedule of Maximum Allowances for Prosthetic and Orthopedic Equipment		
HCPCS	Description	Purchase New
L1650	HO, abd cont hip jnts, stat, adj	\$223
L1652	HO bi thighcuffs w sprdr bar	\$511
L1660	HO, abd cont hip jnts, static	\$209
L1680	HO, abd cont hip jnts, dyn, pel	\$1,318
L1685	HO, abd cont hip jnt, postop	\$1,088
L1686	HO, abd cont hip jnt, postop	\$835
L1690	Combination bilateral HO	\$511
L1700	Legg perthes ortho, Toronto	\$1,570
L1710	Legg perthes ortho, Newington	\$2,018
L1720	Legg perthes ortho, trilateral	\$1,497
L1730	Legg perthes ortho, Scottish rite	\$1,185
L1755	Legg perthes ortho, patten bottom	\$1,448.82
L1810	KO, elastic w/joints	\$98
L1820	KO, elastic w/condylar pads and joint	\$132
L1830	KO, immobilizer, canvas longitud	\$80
L1831	Knee orth pos locking joint	\$422
L1832	KO, adj knee joints, pos orthosis	\$556
L1834	KO, w/o knee joint, rigid, molded	\$710
L1836	Rigid KO wo joints	\$191
L1840	KO, derotation, m-l ant cruc lig	\$1,034
L1843	KO single upright custom fit	\$1,287
L1844	KO, sngl upright, thigh and calf	\$795
L1845	KO, dbl upright, thigh and calf	\$857
L1846	KO, dbl upright, thigh and calf	\$1,059
L1847	KO adjustable w air chambers	\$825
L1850	KO, Swedish type	\$305
L1860	KO, mod supracond prosth socket	\$1,000.78
L1900	AFO, spring wire, dorsiflex asst	\$317
L1902	AFO, ankle gauntlet, custom fit	\$97
L1904	AFO, molded ankle gauntlet, mold	\$430
L1906	AFO, multilig ankle support	\$110
L1907	AFO supramalleolar custom	\$807
L1910	AFO, post, single bar, clasp atta	\$276
L1920	AFO, sngl upright w/stat/adj stop	\$331
L1930	AFO, custom fitted, plastic	\$289
L1932	Afo rig ant tib prefab TCF/=	\$1,280
L1940	AFO, molded to patient, plastic	\$463
L1945	AFO, molded to patient, plastic	\$847
L1950	AFO, spiral, molded to patient	\$684
L1951	AFO spiral prefabricated	\$1,205
L1960	AFO, post solid ankle, molded	\$507
L1970	AFO, plastic molded to patient	\$651
L1971	AFO w/ankle joint, prefab	\$672
L1980	AFO, single upright free plantar	\$351
L1990	AFO, double upright free plantar	\$408
L2000	KAFO, single upright, free	\$928
L2005	KAFO sng/dbl mechanical act	\$5,879
L2010	KAFO, single upright, free ankle	\$906
L2020	KAFO, double upright, free knee	\$1,069
L2030	KAFO, double upright, free ankle	\$937
L2034	KAFO pla sin up w/wo k/a cus	\$2,939
L2035	KAFO plastic pediatric size	\$250
L2036	KAFO, full plastic, double upright	\$1,784
L2037	KAFO, full plastic, single upright	\$1,524
L2038	KAFO, full plastic, w/o knee joint	\$1,308
L2040	HKAFO, torsion control, bilateral	\$162
L2050	HKAFO, torsion control, bilateral	\$517
L2060	HKAFO, torsion control, bilateral	\$598
L2070	HKAFO, torsion control, unilat	\$124
L2080	HKAFO, torsion control, unilat	\$352
L2090	HKAFO, torsion control, unilat	\$426
L2106	AFO, fx ortho, tib fx cast	\$766
L2108	AFO, fx ortho, tib fx cast	\$1,064
L2112	AFO, fx ortho, tib fx orthosis	\$518
L2114	AFO, fx ortho, tib fx orthosis	\$600

Office of Workers' Compensation Schedule of Maximum Allowances for Prosthetic and Orthopedic Equipment		
HCPCS	Description	Purchase New
L2116	AFO, fx ortho, tib fx orthosis	\$719
L2126	KAFO, fx ortho, fem fx cast	\$1,096
L2128	KAFO, fx ortho, fem fx cast	\$1,569
L2132	KAFO, fx ortho, fem fx cast	\$833
L2134	KAFO, fx ortho, fem fx cast	\$1,042
L2136	KAFO, fx ortho, fem fx cast	\$1,179
L2180	Add to lwr extrm fx ortho	\$143
L2182	Add to lwr extrm fx ortho	\$105
L2184	Add to lwr extrm fx ortho	\$136
L2186	Add to lwr extrm fx ortho	\$138
L2188	Add to lwr extrm fx ortho	\$321
L2190	Add to lwr extrm fx ortho	\$92
L2192	Add to lwr extrm fx ortho	\$361
L2200	Add to lwr extrm, limited ankle	\$58
L2210	Add to lwr extrm, dorsiflexion	\$62
L2220	Add to lwr extrm, dorsiflexion	\$80
L2230	Add to lwr extrm, split flat	\$74
L2232	Rocker bottom, contact AFO	\$140
L2240	Add to lwr extrm, round caliper	\$77
L2250	Add to lwr extrm, foot plate	\$325
L2260	Add to lwr extrm, stirrup	\$189
L2265	Add to lwr extrm, stirrup	\$144
L2270	Add to lwr extrm, varus/valgus	\$49
L2275	Varus/vulgus correction, plastic	\$120
L2280	Add to lwr extrm, inner boot	\$414
L2300	Add to lwr extrm, abduction bar	\$329
L2310	Add to lwr extrm, abduction bar	\$150
L2320	Add to lwr extrm, non-mold lacer	\$205
L2330	Add to lwr extrm, lacer molded	\$381
L2335	Add to lwr extrm, ant swing band	\$208
L2340	Add to lwr extrm, pre-tib shell	\$507
L2350	Add to lwr extrm, socket, molded	\$869
L2360	Add to lwr extrm, steel shank	\$63
L2370	Add to lwr extrm, patten bottom	\$269
L2375	Add to lwr extrm, torsion control	\$138
L2380	Add to lwr extrm, torsion control	\$150
L2385	Add to lwr extrm, knee joint	\$158
L2390	Add to lwr extrm, knee joint	\$100
L2395	Add to lwr extrm, knee joint	\$191
L2397	Orthosis, suspension sleeve	\$107
L2405	Add to knee joint, drop lock	\$54
L2415	Add to knee joint, cam lock	\$172
L2425	Add to knee joint, disc/dial loc	\$168
L2492	Add to knee joint, drop lock ring	\$104
L2500	Add to lwr extrm, thigh/weight	\$337
L2510	Add to lwr extrm, thigh/weight	\$764
L2520	Add to lwr extrm, thigh/weight	\$482
L2525	Add to lwr extrm, thigh/weight	\$1,116
L2526	Add to lwr extrm, thigh/weight	\$627
L2530	Add to lwr extrm, thigh/weight	\$217
L2540	Add to lwr extrm, thigh/weight	\$412
L2550	Add to lwr extrm, thigh/weight	\$263
L2570	Add to lwr extrm, hip joint	\$581
L2580	Add to lwr extrm, pelvic sling	\$425
L2600	Add to lwr extrm, hip joint	\$251
L2610	Add to lwr extrm, hip joint	\$296
L2620	Add to lwr extrm, hip joint	\$286
L2622	Add to lwr extrm, hip joint	\$374
L2624	Add to lwr extrm, hip joint	\$325
L2627	Add to lwr extrm, plastic, mold	\$1,569
L2628	Add to lwr extrm, metal frame	\$1,533
L2630	Add to lwr extrm, band and belt	\$268
L2640	Add to lwr extrm, band and belt	\$352
L2650	Add to lwr extrm, pel/thor contr	\$132
L2660	Add to lwr extrm, thoracic contr	\$206

LABOR AND EMPLOYMENT

Office of Workers' Compensation Schedule of Maximum Allowances for Prosthetic and Orthopedic Equipment		
HCPCS	Description	Purchase New
L2670	Add to lwr extrm, thoracic contr	\$208
L2680	Add to lwr extrm, thoracic contr	\$191
L2750	Add to lwr extrm ortho, plating	\$101
L2755	Carbon graphite lamination	\$187
L2760	Add to lwr extrm ortho, extens	\$74
L2768	Ortho sidebar disconnect	\$187
L2780	Add to lwr extrm ortho, non-corr	\$62
L2785	Add to lwr extrm ortho, retainer	\$29
L2795	Add to lwr extrm ortho, knee con	\$90
L2800	Add to lwr extrm ortho, knee con	\$98
L2810	Add to lwr extrm ortho, knee con	\$80
L2820	Add to lwr extrm ortho, soft int	\$79
L2830	Add to lwr extrm ortho, soft int	\$86
L2840	Add to lwr extrm ortho, tib sock	\$53
L2850	Add to lwr extrm ortho, fem sock	\$61
L2861	Torsion mechanism knee/ankle	B.R.
L2999	Unlisted proc lwr extrm orthoses	B.R.
L3000	Foot, insert, "UCB" type	\$162
L3001	Foot, insert, spenco	\$38
L3002	Foot, insert, plastazote	\$81
L3003	Foot, insert, silicone	\$162
L3010	Foot, insert, longitudinal	\$128
L3020	Foot, insert, longitudinal	\$136
L3030	Foot, insert, removable, formed	\$41
L3031	Foot lamin/prepreg composite	B.R.
L3040	Foot, arch support, longitudinal	\$41
L3050	Foot, arch support, metatarsal	\$41
L3060	Foot, arch support, longitudinal	\$54
L3070	Foot, arch support, nonremovable	\$34
L3080	Foot, arch support, nonremovable	\$34
L3090	Foot, arch support, nonremovable	\$47
L3100	Hallus-valgus night dyn splint	\$41
L3140	Foot, abduction rotation bars	\$61
L3150	Foot, abduction rotation bars	\$61
L3160	Shoe styled positioning dev	B.R.
L3170	Foot, plastic heel stabilizer	\$20
L3201	Ortho shoe, oxford, infant	\$50
L3202	Ortho shoe, oxford, child	\$55
L3203	Ortho shoe, oxford, junior	\$70
L3204	Ortho shoe, hightop, infant	\$63
L3206	Ortho shoe, hightop, child	\$53
L3207	Ortho shoe, hightop junior	\$55
L3208	Surgical boot, ea, infant	\$25
L3209	Surgical boot, ea, child	\$30
L3211	Surgical boot, ea, junior	\$58
L3212	Benesch boot, pair, infant	\$66
L3213	Benesch boot, pair, child	B.R.
L3214	Benesch boot, pair, junior	B.R.
L3215	Ortho shoes, ladies, oxford	\$108
L3216	Ortho shoes, ladies, depth inlay	\$150
L3217	Ortho shoes, ladies, hightop	\$163
L3218	Ortho shoes, ladies, surg boot	\$145
L3219	Ortho shoes, mens, oxford	\$126
L3221	Ortho shoes, mens, depth inlay	\$150
L3222	Ortho shoes, mens, hightop	\$163
L3224	Woman's shoe oxford brace	\$88
L3225	Man's shoe oxford brace	\$102
L3230	Ortho shoes, custom, depth inlay	\$482
L3250	Ortho shoes, custom molded	\$270
L3251	Foot, shoe molded to patient	B.R.
L3252	Foot, shoe molded to patient	\$121
L3253	Foot, molded shoe plastazote	\$114
L3254	Non-std size/width	\$193
L3255	Non-std size/length	\$193
L3257	Ortho shoes, add chrg split size	B.R.

Office of Workers' Compensation Schedule of Maximum Allowances for Prosthetic and Orthopedic Equipment		
HCPCS	Description	Purchase New
L3260	Ambulatory surgical boot, ea	\$114
L3265	Plastazote sandal, ea	\$54
L3300	Lift, elevation, heel	\$54
L3310	Lift, elevation, heel and sole	\$47
L3320	Lift, elevation, heel and sole	\$114
L3330	Lift, elevation, metal extension	\$471
L3332	Lift, elevation, inside shoe	\$27
L3334	Lift, elevation, heel, per inch	\$54
L3340	Heel wedge, sach	\$27
L3350	Heel wedge	\$13
L3360	Sole wedge, outside sole	\$13
L3370	Sole wedge, between sole	\$34
L3380	Clubfoot wedge	\$34
L3390	Outflare wedge	\$34
L3400	Metatarsal bar wedge, rocker	\$30
L3410	Metatarsal bar wedge, betw sole	\$47
L3420	Full sole and heel wedge, betw sole	\$54
L3430	Heel, counter, plastic reinforced	\$67
L3440	Heel, counter, leather reinforced	\$47
L3450	Heel, sach cushion type	\$27
L3455	Heel, new leather, std	\$16
L3460	Heel, new rubber, std	\$13
L3465	Heel, Thomas w/wedge	\$16
L3470	Heel, Thomas extended to ball	\$54
L3480	Heel, pad and depression spur	\$41
L3485	Heel, pad, removable spur	B.R.
L3500	Misc shoe add, insole, leather	\$47
L3510	Misc shoe add, insole, rubber	B.R.
L3520	Misc shoe add, insole, felt	B.R.
L3530	Misc shoe add, sole, half	B.R.
L3540	Misc shoe add, sole, full	B.R.
L3550	Misc shoe add, toe tap, std	B.R.
L3560	Misc shoe add, toe tap, horseshoe	B.R.
L3570	Misc shoe add, special extension	B.R.
L3580	Misc shoe add, convert instep	B.R.
L3590	Misc shoe add, convert firm shoe	B.R.
L3595	Misc shoe add, march bar	B.R.
L3600	Trans ortho one to anoth, caliper	\$67
L3610	Trans ortho one to anoth, caliper	\$54
L3620	Trans ortho one to anoth, solid	\$67
L3630	Trans ortho one to anoth, solid	\$67
L3640	Trans ortho one to anoth, dennis	\$34
L3649	Unlisted proc foot ortho shoes	B.R.
L3650	SO, figure "8" design abduction	\$58
L3660	SO, figure "8" design abduction	\$92
L3670	SO, acromio/clavicular	\$105
L3671	SO cap design w/o jnts CF	\$1,176
L3674	SO airplane w/wo joint CF	\$1,543
L3675	Canvas vest SO	\$229
L3677	SO hard plastic stabilizer	B.R.
L3702	EO w/o joints CF	\$377
L3710	EO, elastic w/metal joints	\$133
L3720	EO, dbl upright w/forearm/arm cuffs	\$679
L3730	EO, dbl upright w/forearm/arm cuffs	\$994
L3740	EO, dbl upright w/forearm/arm cuffs	\$1,276
L3760	EO withjoint, Prefabricated	\$653
L3762	Rigid EO wo joints	\$140
L3763	EWHO rigid w/o jnts CF	\$961
L3764	EWHO w/joint(s) CF	\$1,085
L3765	EWHFO rigid w/o jnts CF	\$1,674
L3766	EWHFO w/joint(s) CF	\$1,772
L3806	WHFO w/joint(s) custom fab	\$593
L3807	WHFO, no joint, prefabricated	\$326
L3808	WHFO, rigid w/o joints	\$486
L3900	WHFO, dynamic flexor hinge	\$1,170

Office of Workers' Compensation Schedule of Maximum Allowances for Prosthetic and Orthopedic Equipment		
HCPCS	Description	Purchase New
L3901	WHFO, dynamic flexor hinge	\$1,439
L3904	WHFO, ext powered, electric	\$2,622.33
L3905	WHO w/nontorsion jnt(s) CF	\$1,294
L3906	WHFO, wrist gauntlet, patient model	\$354
L3908	WHFO, wrist extension cock-up	\$54
L3912	WHFO, flex glove w/finger control	\$111.63
L3913	HFO w/o joints CF	\$354
L3915	WHO w nontor jnt(s) prefab	\$694
L3916	WHFO, wrist extension cock-up	\$152
L3917	Prefab metacarp l fx orthosis	\$138
L3919	HO w/o joints CF	\$354
L3921	HFO w/joint(s) CF	\$419
L3923	HFO w/o joints PF	\$128
L3925	FO pip/dip with joint/spring	\$73
L3927	FO pip/dip w/o joint/spring	\$46
L3929	HFO nontorsion joint, prefab	\$115
L3931	WHFO nontorsion joint prefab	\$268
L3933	FO w/o joints CF	\$279
L3935	FO nontorsion joint CF	\$288
L3956	Add joint upper ext orthosis	B.R.
L3960	SEWHO, abduction	\$802.41
L3961	SEWHO cap design w/o jnts CF	\$2,193
L3962	SEWHO, abduction positioning, erbs	\$642
L3967	SEWHO airplane w/o jnts CF	\$2,589
L3971	SEWHO cap design w/jnt(s) CF	\$2,458
L3973	SEWHO airplane w/jnt(s) CF	\$2,589
L3975	SEWHFO cap design w/o jnt CF	\$2,193
L3976	SEWHFO airplane w/o jnts CF	\$2,193
L3977	SEWHFO cap desgn w/jnt(s) CF	\$2,458
L3978	SEWHFO airplane w/jnt(s) CF	\$2,589
L3980	Upr extrm fx ortho, humeral	\$330
L3982	Upr extrm fx ortho, radius/ulnar	\$372
L3984	Upr extrm fx ortho, wrist	\$324
L3985	Upr extrm fx ortho, forearm, hand	\$523
L3999	Unlisted proc upr limb orthosis	B.R.
L4000	Repl girdle Milwaukee orthosis	\$1,233
L4002	Replace strap, any orthosis	B.R.
L4010	Repl trilateral socket brim	\$630
L4020	Repl quad socket brim, molded	\$922
L4030	Repl quad socket brim, custom	\$603
L4040	Repl molded thigh lacer	\$393
L4045	Repl nonmolded thigh lacer	\$300
L4050	Repl molded calf lacer	\$378
L4055	Repl non-molded calf lacer	\$249
L4060	Repl high roll cuff	\$291
L4070	Repl prox and dist upright KAFO	\$324
L4080	Repl met bands KAFO, prox thigh	\$93
L4090	Repl met bands KAFO-AFO, calf/thigh	\$105
L4100	Repl leath cuff KAFO, prox thigh	\$107
L4110	Repl leath cuff KAFO-AFO, calf/thigh	\$86
L4130	Repl pretibial shell	\$529
L4205	Ortho dvc repair per 15 min	B.R.
L4210	Repair orthotic device, minor parts	\$57
L4350	Pneumatic ankle control splint	\$84
L4370	Pneumatic full leg splint	\$173
L4386	Non-pneum walk boot prefab	\$227
L4392	Replace AFO soft interface	\$34
L4394	Replace foot drop spint	\$25
L4396	Static AFO	\$240
L4631	Afo, walk boot type, cus fab	\$2,212
L5000	Part foot, shoe insrt w/arch, toe	\$657
L5010	Part foot, mold sockt, w/toe filler	\$1,491
L5020	Part foot, mold sockt, tib hght	\$2,240
L5050	Ankle, Symes, mold socket, sach	\$2,820
L5060	Ankle, Symes, metal frame, molded l	\$3,187

Office of Workers' Compensation Schedule of Maximum Allowances for Prosthetic and Orthopedic Equipment		
HCPCS	Description	Purchase New
L5100	Below knee, molded socket, shin	\$2,771
L5105	Below knee, plastic socket	\$3,387
L5150	Knee disartic, molded socket, ext	\$4,037
L5160	Knee disartic, molded socket, bent	\$4,247
L5200	Above knee, mold socket, snlg axis	\$3,691
L5210	Above knee, shrt prosth, no knee	\$2,728
L5220	Above knee, shrt prosth, no knee	\$3,428
L5230	Above knee, prox fem focal defic	\$4,063
L5250	Hip disartic, Canadian type; molded	\$5,500
L5270	Hip disartic, tilt table type; mold	\$5,227
L5280	Hemipelvectomy, Canadian type; molded	\$5,689
L5300	Below knee, molded socket, sach ft	\$3,211
L5301	BK mold socket SACH ft endo	\$3,672
L5312	Knee disart, SACH ft, endo	\$5,276
L5321	AK open end SACH	\$5,257
L5331	Hip disart canadian SACH ft	\$7,438
L5341	Hemipelvectomy canadian SACH	\$8,083
L5400	Immed postop/early fitting	\$1,390
L5410	Immed postop/early fitting	\$543
L5420	Immed postop/early fitting	\$1,781
L5430	Immed postop/early fitting	\$654
L5450	Immed postop/early fitting	\$530
L5460	Immed postop/early fitting	\$709
L5500	Init, below knee "PTB" type socket	\$1,399
L5505	Init, above knee, ischial level soc	\$2,261
L5510	Prep, below knee "PTB" type socket	\$1,663
L5520	Prep, below knee "PTB" type socket	\$1,869
L5530	Prep, below knee "PTB" type socket	\$1,932
L5535	Prep, below knee "PTB" type	\$1,936
L5540	Prep, below knee "PTB" type	\$2,075
L5560	Prep, above knee-knee disarticulat	\$2,496
L5570	Prep, above knee-knee disarticulat	\$2,464
L5580	Prep, above knee-knee disarticulat	\$2,752
L5585	Prep, above knee-knee disarticulat	\$2,761
L5590	Prep, above knee-knee disarticulat	\$2,701
L5595	Prep, hip disartic-hemipelvectomy	\$3,926
L5600	Prep, hip disartic-hemipelvectomy	\$4,335
L5610	Add to lwr extrm, above knee, hydra	\$2,339
L5611	Add to lwr extrm, above knee-knee	\$1,571
L5613	Add to lwr extrm, above knee-knee	\$2,419
L5614	Abv knee-knee disartic	\$3,877
L5616	Add to lwr extrm, above knee, univ	\$1,765
L5617	AK/BK self-aligning unit ea	\$809
L5618	Add to lwr extrm, test sockt, Symes	\$295
L5620	Add to lwr extrm, test sockt	\$361
L5622	Add to lwr extrm, test sockt, knee	\$471
L5624	Add to lwr extrm, test sockt	\$473
L5626	Add to lwr extrm, test sockt, hip	\$519
L5628	Add to lwr extrm, test sockt, hemi	\$560
L5629	Add to lwr extrm, below knee, acry	\$413
L5630	Add to lwr extrm, Symes type, expa	\$504
L5631	Add to lwr extrm, above knee/knee	\$571
L5632	Add to lwr extrm, Symes type	\$216
L5634	Add to lwr extrm, Symes type, post	\$297
L5636	Add to lwr extrm, Symes type, med	\$248
L5637	Add to lwr extrm, below knee, tot	\$376
L5638	Add to lwr extrm, below knee, leat	\$492
L5639	Add to lwr extrm, below knee, wood	\$1,093
L5640	Add to lwr extrm, knee, leather	\$623
L5642	Add to lwr extrm, above knee, leat	\$623
L5643	Add to lwr extrm, hip disartic	\$1,632
L5644	Add to lwr extrm, above knee, wood	\$687
L5645	Add to lwr extrm, below knee, flex	\$779
L5646	Add to lwr extrm, below knee, air	\$693
L5647	Add to lwr extrm, below knee suct	\$776

LABOR AND EMPLOYMENT

Office of Workers' Compensation Schedule of Maximum Allowances for Prosthetic and Orthopedic Equipment		
HCPCS	Description	Purchase New
L5648	Add to lwr extrm, above knee, air	\$756
L5649	Add to lwr extrm, Ischial contain	\$2,369
L5650	Adds to lwr extrm, total contact	\$558
L5651	Add to lwr extrm, above knee, flex	\$1,561
L5652	Add to lwr extrm, suction suspens	\$496
L5653	Add to lwr extrm, knee disartic	\$581
L5654	Add to lwr extrm, sockt insrt, sym	\$384
L5655	Add to lwr extrm, sockt insrt, bel	\$299
L5656	Add to lwr extrm, sockt insrt	\$371
L5658	Add to lwr extrm, sockt insrt, abv	\$354
L5661	Add to lwr extrm, sockt insrt, mul	\$593
L5665	Add to lwr extrm, sockt insrt, mul	\$534
L5666	Add to lwr extrm, below knee, cuff	\$91
L5668	Add to lwr extrm, below knee, mold	\$131
L5670	Add to lwr extrm, below knee, mold	\$353
L5671	BK/AK locking mechanism	\$796
L5672	Add to lwr extrm, below knee, remv	\$291
L5673	Socket insert w lock mech	\$1,069
L5676	Adds to lwr extrm, below knee	\$460
L5677	Adds to lwr extrm, below knee	\$641
L5678	Adds to lwr extrm, below knee	\$52
L5679	Socket insert w/o lock mech	\$891
L5680	Add to lwr extrm, below knee, lacer	\$318
L5681	Intl custm cong/latyp insert	\$1,891
L5682	Add to lwr extrm, below knee, lacer	\$622
L5683	Initial custom socket insert	\$1,891
L5684	Add to lwr extrm, below knee, strap	\$52
L5685	Bk back check	\$184
L5686	Add to lwr extrm, below knee, check	\$53
L5688	Add to lwr extrm, below knee, belt	\$75
L5690	Add to lwr extrm, below knee, belt	\$105
L5692	Add to lwr extrm, above knee, belt	\$173
L5694	Add to lwr extrm, above knee, belt	\$236
L5695	Add to lwr extrm, above knee, belt	\$212
L5696	Add to lwr extrm, above knee/disar	\$216
L5697	Add to lwr extrm, above knee/disar	\$78
L5698	Add to lwr extrm, above knee/disar	\$117
L5699	All lwr extrm prosth, shldr harnes	\$182
L5700	Repl, socket, blw knee	\$2,793
L5701	Repl, socket, abv knee/knee disarti	\$3,354
L5702	Repl, socket, hip disarticulation,	\$4,244
L5703	Symes ankle w/o (SACH) foot	\$3,346
L5704	Repl, cust prot cover, blw knee	\$523
L5705	Repl, cust prot cover, abv knee	\$934
L5706	Repl, cust prot cover, knee disarti	\$915
L5707	Repl, cust prot cover, hip disartic	\$1,207
L5710	Add, exo knee-shin sys, manual lock	\$417
L5711	Adds exo knee-shin sys, manual lock	\$529
L5712	Add, exo knee-shin sys, friction sw	\$554
L5714	Add, exo knee-shin sys, variable fr	\$468
L5716	Add, exo knee-shin sys, mechanical	\$827
L5718	Add, exo knee-shin sys, friction sw	\$913
L5722	Add, exo knee-shin sys, pneum swing	\$887
L5724	Add, exo knee-shin sys, fluid swing	\$1,962
L5726	Add, exo knee-shin sys, ext joints	\$2,261
L5728	Add, exo knee-shin sys, fluid swing	\$2,416
L5780	Add, exo knee-shin sys, pneumatic	\$1,286
L5781	Lower limb pros vacuum pump	\$5,750
L5782	HD low limb pros vacuum pump	\$6,062
L5785	Add, exo sys, blw knee, ult-lit mat	\$565
L5790	Add, exo sys, abv knee, ult-lit mat	\$935
L5795	Add, exo sys, hip dis, ult-lit mat	\$1,396
L5810	Add, endo knee-shin sys, manual lck	\$524
L5811	Add, endo knee-shin sys, manual lck	\$776
L5812	Add, endo knee-shin sys, frict swng	\$587

Office of Workers' Compensation Schedule of Maximum Allowances for Prosthetic and Orthopedic Equipment		
HCPCS	Description	Purchase New
L5814	Endo knee-shin hydal swg ph	\$5,337
L5816	Add, endo knee-shin sys, mech stanc	\$945
L5818	Add, endo knee-shin sys, frict swng	\$947
L5822	Add, endo knee-shin sys, pneum swng	\$1,660
L5824	Add, endo knee-shin sys, fluid swng	\$1,781
L5826	Miniature knee joint	\$4,516
L5828	Add, endo knee-shin sys, fluid swng	\$2,753
L5830	Add, endo knee-shin sys, pneum swng	\$2,030
L5840	Add, endoskel knee/shin sys	\$2,355
L5845	Knee-shin sys stance flexion	\$2,576
L5848	Knee-shin sys hydal stance	\$1,545
L5850	Add, endo sys, abv knee/hip disart	\$166
L5855	Add, hip disarticulation, mech	\$335
L5856	Elec knee-shin swing/stance	\$34,548
L5857	Elec knee-shin swing only	\$12,291
L5858	Stance phase only	\$26,708
L5910	Add, endo sys, blw knee, alignable	\$471
L5920	Add, endo sys, abv knee/hip disart	\$690
L5925	Add, abv knee, knee disarticulation	\$437
L5930	High activity knee frame	\$4,868
L5940	Add, endo sys, blw knee, ult-lit	\$652
L5950	Add, endo sys, abv knee, ult-lit	\$1,011
L5960	Add, endo sys, hip dis, ult-lit	\$1,253
L5961	Endo poly hip, pneu/hyd/rot	\$6,844
L5962	Add, blw knee, flex prot cover	\$618
L5964	Add, abv knee, flex prot cover	\$913
L5966	Add, hip disartic, flex prot cover	\$1,163
L5968	Multiaxial ankle w dorsiflex	\$5,222
L5970	All lwr extr pros, foot, ext keel	\$222
L5971	SACH foot, replacement	\$325
L5972	All lwr extr pros, flex keel foot	\$418
L5973	Ank-foot sys dors-plant flex	\$25,078
L5974	All lwr extr pros, foot, ankle/foot	\$258
L5975	Combo ankle/foot prosthesis	\$666
L5976	All lwr extr pros, energy storing	\$592
L5978	All lwr extr pros, foot, ankle/foot	\$332
L5979	Multiaxial ankle/foot, dynamic resp	\$2,225
L5980	All lwr extr pros, flex foot system	\$3,823
L5981	Flex-walk sys/equal	\$2,920
L5982	All exo etal lwr extrm pros, axial	\$610
L5984	All endo lwr extrm pros, axial rot	\$655
L5985	Lwr ext dynamic prosth pylon	\$408
L5986	All lwr extrm prosth, multi-axial	\$652
L5987	Shank ft w vert load pylon	\$10,338
L5988	Vertical shock reducing pylo	\$2,871
L5990	User adjustable heel height	\$2,607
L5999	Unlisted proc lwr extrm prosth	B.R.
L6000	Part hand, thumb remaining	\$1,459
L6010	Part hand, little/ring finger rem	\$1,468
L6020	Part hand, no finger remaining	\$1,460
L6025	Part hand disart myoelectric	\$11,500
L6050	Wrist disartic, mold sockt, flex	\$2,243
L6055	Wrist disartic, mold sockt w/expan	\$2,767
L6100	Blw elbow, molded socket, flex	\$2,302
L6110	Blw elbow, molded socket	\$2,443
L6120	Blw elbow, mold dbl wall split sock	\$2,755
L6130	Blw elbow, mold dbl wall split sock	\$2,553
L6200	Elbow disartic, mold socket	\$3,106
L6205	Elbow disartic, mold socket	\$3,550
L6250	Above elbow, mold dbl wall socket	\$3,221
L6300	Shldr disart, mold socket, bulkhead	\$3,878
L6310	Shldr disart, pass restor	\$3,114
L6320	Shldr disart, pass restor	\$1,873
L6350	Int-scap thor, mold sockt, bulkhead	\$3,819
L6360	Int-scap thor, pass restor	\$3,105

Office of Workers' Compensation Schedule of Maximum Allowances for Prosthetic and Orthopedic Equipment		
HCPCS	Description	Purchase New
L6370	Int-scap thor, pass restor	\$2,165
L6380	Immed postop/early fit, init rigid	\$1,280
L6382	Immed postop/early fit, init rigid	\$1,518
L6384	Immed postop/early fit, init rigid	\$1,882
L6386	Immed postop/early fit, cast change	\$436
L6388	Immed postop/early fit, rigid dress	\$487
L6400	Blw elbow, mold sockt, endo sys	\$2,445
L6450	Elbow disart, mold sockt, endo sys	\$3,006
L6500	Above elbow, mold sockt, endo sys	\$3,033
L6550	Shoulder disart, mold sockt, endo	\$3,718
L6570	Interscap thor, mold sockt, endo	\$4,267
L6580	Prep, wrist disart/blw elbow	\$1,602
L6582	Prep, wrist disart/blw elbow	\$1,486
L6584	Prep, elbow disart/above elbow	\$2,170
L6586	Prep, elbow disart/above elbow	\$2,135
L6588	Prep, shldr disart/int-scap thorac	\$2,940
L6590	Prep, shldr disart/int-scap thorac	\$2,883
L6600	Upr extrm adds, polycent hinge, pr	\$244
L6605	Upr extrm adds, sng pivot hinge, pr	\$241
L6610	Upr extrm adds, flex metal hing, pr	\$197
L6611	Additional switch, ext pwr	\$592
L6615	Upr extrm add, disc locking wrist	\$189
L6616	Upr extrm add, add disc locking wr	\$80
L6620	Upr extrm add, flexion-friction wr	\$327
L6621	Flex/ext wrist w/wo friction	\$3,287
L6623	Upr extrm add, spring asst rotl wr	\$657
L6624	Flex/ext/rotation wrist unit	\$5,412
L6625	Upr extrm add, rot wrist unit	\$691
L6628	Upr extrm add, quick disc hook adap	\$503
L6629	Upr extrm add, quick disc lam coll	\$173
L6630	Upr extrm add, stain steel, wrist	\$280
L6632	Upr extrm add, latex susp sleeve	\$63
L6635	Upr extrm add, lift assist elbow	\$216
L6637	Upr extrm add, nudge cont elbw lck	\$420
L6638	Elec lock on manual pw elbow	\$3,594
L6640	Upr extrm adds, shldr abd joint, pr	\$352
L6641	Upr extrm add, excurs amp, pulley	\$190
L6642	Upr extrm add, excurs amp, lever	\$226
L6645	Upr extrm add, shldr flex-abduction	\$393
L6646	Multipo locking shoulder jnt	\$4,532
L6647	Shoulder lock actuator	\$746
L6648	Ext pwrd shlder lock/unlock	\$4,675
L6650	Upr extrm add, shldr univ joint, ea	\$412
L6655	Upr extrm add, std cont cable	\$90
L6660	Upr extrm add, heavy duty cont cable	\$101
L6665	Upr extrm add, teflon, cable lining	\$60
L6670	Upr extrm add, hook-hand, cable	\$62
L6672	Upr extrm add, harness, chest	\$173
L6675	Upr extrm add, harness, figure "8"	\$122
L6676	Upr extrm add, harness, figure "8"	\$128
L6677	UE triple control harness	\$426
L6680	Upr extrm add, test sockt, wrist	\$302
L6682	Upr extrm add, test sockt, elbow	\$295
L6684	Upr extrm add, test sockt, shldr	\$340
L6686	Upr extrm add, suction socket	\$632
L6687	Upr extrm add, frame type socket	\$562
L6688	Upr extrm add, frame type socket	\$665
L6689	Upr extrm add, frame type socket	\$696
L6690	Upr extrm add, frame type socket	\$755
L6691	Upr extrm add, removable insert, each	\$337
L6692	Upr extrm add, silicone gel insert	\$694
L6693	Lockingelbow forearm cntrbal	\$4,080
L6694	Elbow socket ins use w/lock	\$1,069
L6695	Elbow socket ins use w/o lck	\$891
L6696	Cus elbo skt in for con/atyp	\$1,891

Office of Workers' Compensation Schedule of Maximum Allowances for Prosthetic and Orthopedic Equipment		
HCPCS	Description	Purchase New
L6697	Cus elbo skt in not con/atyp	\$1,891
L6698	Below/above elbow lock mech	\$796
L6704	Term dev, sport/rec/work att	\$937
L6706	Term dev mech hook vol open	\$558
L6707	Term dev mech hook vol close	\$2,057
L6708	Term dev mech hand vol open	\$1,338
L6709	Term dev mech hand vol close	\$1,938
L6711	Ped term dev, hook, vol open	\$966
L6712	Ped term dev, hook, vol clos	\$1,779
L6713	Ped term dev, hand, vol open	\$2,245
L6714	Ped term dev, hand, vol clos	\$1,902
L6715	Term device, hook, dorr, mod #5xa	\$391
L6721	Hook/hand, hvy dty, vol open	\$3,380
L6722	Hook/hand, hvy dty, vol clos	\$2,914
L6805	Term device, mod wrist flex unit	\$414.87
L6810	Term dev, pinch tool, Otto Bock	\$242.46
L6880	Term dev, hand, Bock, vo	\$651
L6881	Term dev auto grasp feature	\$5,875
L6882	Microprocessor control uplmb	\$4,457
L6883	Replc sockt below e/w disa	\$2,538
L6884	Replc sockt above elbow disa	\$3,571
L6885	Replc sockt shldr dis/interc	\$5,094
L6890	Term dev, glove abv hands, glove	\$180
L6895	Term dev, glove abv hands, glove	\$544
L6900	Hand restoration	\$1,507
L6905	Hand restoration	\$1,431
L6910	Hand restoration	\$1,411
L6915	Hand restoration	\$610
L6920	Wrist disart, ext pwr, inner socket	\$7,144
L6925	Wrist disart, ext pwr, inner socket	\$7,544
L6930	Blw elbow, ext pwr, inner socket	\$7,670
L6935	Blw elbow, ext pwr, inner socket	\$8,437
L6940	Elbow disart, ext pwr, inner socket	\$9,586
L6945	Elbow disart, ext pwr, inner socket	\$10,844
L6950	Above elbow, ext pwr, inner socket	\$10,192
L6955	Above elbow, ext pwr, inner socket	\$12,789
L6960	Shldr disart, ext pwr, inner socket	\$12,611
L6965	Shldr disart, ext pwr, inner socket	\$18,423
L6970	Int-scap-thor, ext pwr, inner socket	\$18,726
L6975	Int-scap-thor, ext pwr, inner socket	\$18,826
L7007	Adult electric hand	\$5,504
L7008	Pediatric electric hand	\$8,662
L7009	Adult electric hook	\$5,616
L7040	Prehens act, Hosmer/equal, switch	\$3,665
L7045	Elect hook, child, Michigan/equal	\$2,101
L7170	Elect elbw, Hosmer/equal, switch	\$7,622
L7180	Elect elbw, Utah/equal, myoelectr	\$39,823
L7181	Electronic elbo simultaneous	\$57,580
L7185	Elect elbw, adolescent, var village	\$7,718
L7186	Elect elbw, child, var village	\$11,139
L7190	Elect elbw, adolescent, var village	\$9,820
L7191	Elect elbw, child, var village	\$11,841
L7260	Elect wrist rotator, Otto Bock/equa	\$2,558
L7261	Elect wrist rotator, Utah arm	\$4,094
L7360	Six vlt bat, Otto Bock/equal, ea	\$235
L7362	Bat charger, six volt, Otto Bock	\$282
L7364	Twelve volt bat, Utah/equal, ea	\$514
L7366	Batt charger, twelve volt, Utah/equ	\$698
L7367	Replacemnt lithium ionbatter	\$559
L7368	Lithium ion battery charger	\$725
L7400	Add UE prost be/wd, ultlite	\$440
L7401	Add UE prost a/e ultlite mat	\$493
L7402	Add UE prost s/d ultlite mat	\$532
L7403	Add UE prost b/e acrylic	\$529
L7404	Add UE prost a/e acrylic	\$799

LABOR AND EMPLOYMENT

Office of Workers' Compensation Schedule of Maximum Allowances for Prosthetic and Orthopedic Equipment		
HCPCS	Description	Purchase New
L7405	Add UE prost s/d acrylic	\$1,045
L7499	Unlisted procs upr extrm prosth	B.R.
L7510	RPR prosth dev, rpr/rep minor parts	\$57
L7520	Repair prosthesis per 15 min	B.R.
L7600	Prosthetic donning sleeve	B.R.
L7900	Male vacuum erection system	\$771
L8000	Breast prosth, mastectomy bra	\$37
L8001	Breast prosthesis bra and form	\$180
L8002	Brst prsth bra and bilat form	\$237
L8010	Breast prosth, mastectomy sleeve	\$59
L8015	Ext breastprosthesis garment	\$86
L8020	Breast prosth, mastectomy form	\$222
L8030	Breast prosth, silicone/equal	\$325
L8031	Breast prosthesis w adhesive	\$505
L8032	Reusable nipple prosthesis	\$56
L8035	Custom breast prosthesis	\$5,265
L8039	Breast prosthesis NOS	B.R.
L8040	Nasal prosthesis	\$3,559
L8040	Nasal prosthesis	KM \$3,381
L8040	Nasal prosthesis	KN \$1,424
L8041	Midfacial prosthesis	\$4,290
L8041	Midfacial prosthesis	KM \$4,076
L8041	Midfacial prosthesis	KN \$1,716
L8042	Orbital prosthesis	\$4,820
L8042	Orbital prosthesis	KM \$4,579
L8042	Orbital prosthesis	KN \$1,928
L8043	Upper facial prosthesis	\$5,399
L8043	Upper facial prosthesis	KM \$5,129
L8043	Upper facial prosthesis	KN \$2,160
L8044	Hemi-facial prosthesis	\$5,977
L8044	Hemi-facial prosthesis	KM \$5,678
L8044	Hemi-facial prosthesis	KN \$2,391
L8045	Auricular prosthesis	\$3,933
L8045	Auricular prosthesis	KM \$3,736
L8045	Auricular prosthesis	KN \$1,572
L8046	Partial facial prosthesis	\$3,856
L8046	Partial facial prosthesis	KM \$3,663
L8046	Partial facial prosthesis	KN \$1,543
L8047	Nasal septal prosthesis	\$1,976
L8047	Nasal septal prosthesis	KM \$1,878
L8047	Nasal septal prosthesis	KN \$791
L8048	Unspec maxillofacial prosth	B.R.
L8049	Repair maxillofacial prosth	B.R.
L8300	Truss, single w/std pad	\$82
L8310	Truss, dbl w/std pads	\$130
L8320	Truss, add to std pad, water pad	\$60
L8330	Truss, add to std pad, scrotal pad	\$64
L8400	Prosth sheath, blw knee, ea	\$15
L8410	Prosth sheath, above knee, ea	\$22
L8415	Prosth sheath, upr limb, ea	\$23
L8417	Pros sheath/sock w gel cushn	\$108
L8420	Prosth sock, wool, blw knee, ea	\$20
L8430	Prosth sock, wool, above knee, ea	\$22
L8435	Prosth sock, wool, upr limb, ea	\$24
L8440	Prosth shrinker, blw knee, ea	\$43
L8460	Prosth shrinker, above knee, ea	\$75
L8465	Prosth shrinker, upr limb, ea	\$53
L8470	Stump sock, sngl ply, fit, blw knee	\$8
L8480	Stump sock, sngl ply, fit, abv knee	\$10
L8485	Stump sock, single ply, fitting	\$11
L8499	Unlisted procedure misc prosth	B.R.
L8500	Artificial larynx, any type	\$758
L8501	Tracheostomy speaking valve	\$118
L8505	Artificial larynx, accessory	B.R.
L8507	Trach-esoph voice pros pt in	\$60

Office of Workers' Compensation Schedule of Maximum Allowances for Prosthetic and Orthopedic Equipment		
HCPCS	Description	Purchase New
L8509	Trach-esoph voice pros md in	\$157
L8510	Voice amplifier	\$363
L8511	Indwelling trach insert	\$105
L8512	Gel cap for trach voice pros	\$3
L8513	Trach pros cleaning device	\$7
L8514	Repl trach puncture dilator	\$136
L8515	Gel cap app device for trach	\$91
L8600	Implant breast prosth, silicone/equ	\$999
L8609	Artificial cornea	\$9,365
L8610	Ocular	\$936
L8612	Aqueous shunt	\$972
L8613	Ossicula	\$411
L8614	Cochlear dev/system	\$27,796
L8615	Temporomandibular joint	\$648
L8616	Maxilla	\$151
L8617	Mandible	\$132
L8618	Palate	\$38
L8619	Coch imp ext proc/contr rplc	\$11,931
L8621	Distal humerus	\$1
L8622	Proximal ulna/radius	\$1
L8623	Distal ulna	\$93
L8624	Distal radius	\$232
L8627	Lunate	\$10,133
L8628	Carpus	\$1,798
L8629	Scaphoid	\$257
L8630	Metacarpophalangeal joint	\$539
L8631	MCP joint repl 2 pc or more	\$3,162
L8641	Metatarsal joint	\$560
L8642	Hallux implant	\$454
L8658	Interphalangeal joint	\$488
L8659	Interphalangeal joint repl	\$2,774
L8670	Vascular graft material, synthetic	\$801
L8680	Biliary stent, endoprosth (perm)	\$668
L8681	Pt prgrm for implt neurostim	\$1,725
L8682	Implt neurostim radiofq rec	\$8,666
L8683	Radiofq trsmtr for implt neu	\$7,628
L8684	Radiof trsmtr implt scr1 neu	\$1,089
L8685	Implt nrostm pls gen sng rec	\$19,010
L8686	Implt nrostm pls gen sng non	\$12,121
L8687	Implt nrostm pls gen dua rec	\$24,739
L8688	Implt nrostm pls gen dua non	\$15,785
L8689	External recharg sys intern	\$2,479
L8690	Testicle	\$6,838
L8691	Osseointegrated snd proc rpl	\$3,833
L8692	Non-osseointegrated snd proc	B.R.
L8693	Aud osseo dev, abutment	\$2,180
L8695	External recharg sys extern	\$24
L8699	Prosthetic implant NOS	B.R.
L9900	O and P supply/accessory/service	B.R.
L9999	Sales tax, orthotic/prosth/other	B.R.

AUTHORITY NOTE: Promulgated in accordance with R.S. 23:1034.2.

HISTORICAL NOTE: Promulgated by the Department of Labor, Office of Workers' Compensation, LR 19:54 (January 1993), repromulgated LR 19:212 (February 1993), amended LR 20:1299 (November 1994), amended by the Workforce Commission, Office of Workers' Compensation, LR 39:1847 (July 2013), LR 40:375 (February 2014).

## Chapter 45. Respiratory Services Reimbursement Schedule, Billing Instructions, and Maintenance Procedures

Editor's Note: Other Sections applying to this Chapter can be found in Chapter 51.

### §§4501-4505. Reserved.

### §4507. Prior Authorization

A. Except in documented emergencies, all equipment, supplies and services described herein, except those specifically noted, must have prior written authorization of the carrier/self-insured employer before reimbursement will be made. Claimants should be notified of this requirement in writing upon the initiation of the claim. Each authorization request must include a prescription or statement of need from the treating physician of record.

B. Prior authorization requests will be approved, denied, or amended and approved by the carrier/self-insured employer. Occasionally, some requests may be returned for further information, explanation, or reports. Once a request is approved, please take great care to bill only for those procedures or services specifically authorized by the carrier/self-insured employer. In addition, please attach the authorization letter to the invoice or enter the prior authorization number in the appropriate field on the invoice.

C. The following must be taken into account when making a prior authorization request.

1. The prescription or the letter of justification from the claimant's physician is the key factor in obtaining prior authorization of the carrier/self-insured employer and reimbursement. For oxygen requests, the type and amount, the frequency, and method of delivery also must be specified. In addition, the physician should list the estimated requirements for ancillary supplies.

2. For approved rentals and supplies, a specific period of authorization will be established based on the recommendation of the physician who issues the prescription. At the end of this initial period, if there is a continuing need for equipment or supplies, it is the provider's responsibility to obtain a new prescription, the prognosis and a new estimate of the period of need. The provider should make the continuing authorization request and attach the prescription.

3. For equipment rental and purchase request, the item's model and serial number and a description of the warranty coverage must be included with the request. The carrier/self-insured employer is authorized to require a consultation prior to approval of any equipment or supplies.

**AUTHORITY NOTE:** Promulgated in accordance with R.S. 23:1034.2.

**HISTORICAL NOTE:** Promulgated by the Department of Labor, Office of Workers' Compensation, LR 19:54 (January 1993), repromulgated LR 19:212 (February 1993), amended LR 20:1299 (November 1994).

### §4509. Covered Services

A. All equipment, supplies and related services must be pre-authorized for reimbursement to be made. Services and equipment must be provided by providers who have qualified professional support staff to install and monitor the equipment, such as registered nurses, licensed practical nurses, or certified respiratory therapists. The claimant's authorized physician must prescribe continuous oxygen based upon the physician's interpretation of a blood oxygen report (i.e., arterial blood gas or oximetry) that was performed no more than 12 months prior to the authorization request. On occasion, a pulmonologist consultation may be requested. An annual blood oxygen analysis report is recommended for continued authorization of oxygen therapy.

B. Standard Oxygen Systems Versus Oxygen Concentrators. Oxygen concentrators will be considered only for claimants who require continuous daily oxygen for a minimum of 8 hours in a 24-hour period. Prior authorization requests to deliver more than standard amounts of oxygen will be reviewed by the carrier/self-insured employer with the requesting physician to determine if an oxygen concentrator would be a better option.

C. Portable Oxygen. At the request of the prescribing physician, the carrier/self-insured employer may authorize portable oxygen in three instances:

1. as a back up to an oxygen concentrator for claimants on continuous oxygen who need oxygen to go for routine medical treatment or visits;
2. for those claimants whose record documents eight or more hours of daily activity; and
3. when requested by the attending physician and approved by the carrier/self-insured employer for certain rehabilitation and recreational uses.

D. Miscellaneous Respiratory Equipment. Intermittent Positive Pressure Breathing (IPPB) machines, nebulizers, humidifiers, vaporizers and suction pumps are covered when prescribed by the treating physician of record.

E. Supplies. Those supplies directly related to the functioning or patient's usage of the respiratory equipment should be itemized along with the equipment in the same authorization request. These supplies should be billed using the codes listed in the "Schedule of Maximum Allowances" section of this manual.

### F. Equipment Rental/Purchase Guidelines

1. Whenever the total of prospective rental payments for the period of medical need as stated by the prescribing physician equals or exceeds the maximum allowable purchase price, the provider should request a purchase instead of a rental in his/her prior authorization request. All new items with a maximum allowable rate of \$150 or less and used items with an approved resale value quotation of \$150 or less will be allowed as purchases only, regardless of the expected period of medical need.

## LABOR AND EMPLOYMENT

2. If however, a definite period of medical need cannot be determined at the time of the initial request, a rental authorization will be granted under the following conditions.

a. For any item which was used when the rental period began, the item will be considered purchased at the point that a monthly rental payment matches or first approximates the provider's resale value quotation (for that specific piece of equipment) in the original authorization request.

b. For any item which was new when the rental period began, the item will be considered purchased at the point that a monthly rental payment matches or first approximates\* 100 percent of the carrier/self-insured employer's maximum allowable purchase price.

\*Maximum rental periods for new items are listed in the "Schedule of Maximum Allowances."

3. If a claimant's medical condition changes or does not improve as expected, a rental may be discontinued in favor of a purchase. In such instances, the same policy outlined above will determine the purchase payment amount. The carrier/self-insured employer reserves the right to reevaluate the rental/purchase option at any time within the authorized rental period. Once purchased by the carrier/self-insured employer, any item becomes the property of the claimant.

4. If death or other disqualifying factors intervene, rental fees for equipment will terminate at the end of the month such circumstance(s) occurred and no further payment will be made regardless of the original rental period authorized.

5. The return of the rented equipment is the dual responsibility of the claimant and the provider. The carrier/self-insured employer is not responsible and will not reimburse for additional rental periods solely because of a delay in equipment return.

### G. Equipment Warranty Information

1. If a repair authorization is requested, the provider must furnish a copy of the warranty or a statement of warranty denial from the manufacturer. If the warranty period has expired, the filed information must include the date of purchase from the manufacturer and the warranty period allowed.

2. The monthly rental fee allowed for services shall include a full service warranty during the authorized rental period. In addition, routine maintenance, repairs and replacement of rental equipment is the responsibility of the provider.

### H. Professional Respiratory Care Services

1. All professional respiratory care services must be:

a. ordered by a physician who specifies the type, frequency, and duration of treatment and, as appropriate, the type and doses of medication, the type of diluent, and the oxygen concentration;

b. consistent with the patient's diagnosis and treatment and assessment of respiratory problems;

c. diagnostic or therapeutic;

d. for acute or chronic respiratory problems; and

e. provided by a physician, registered or certified respiratory therapist, cardiopulmonary technologist or an appropriately trained licensed nurse.

2. Covered professional services include, but are not limited to:

a.i. ventilation assist and management initiation—this service is not necessarily confined to the critical care area. It can be rendered in a hospital setting or in rare instances the Extended Care Facility (ECF) or home setting. Ventilation assist and management initiation normally includes:

(a). patient's history, physical examinations;

(b). consultation;

(c). continuous positive airway pressure ventilation;

(d). continuous negative pressure ventilation;

(e). establishment of a mechanism necessary for the monitoring of the patient;

(f). evaluation of all laboratory procedures; and

(g). adjustment of treatment plans and maintenance of medical records;

ii. reimbursement for subsequent days of ventilation assist and management is limited to 13 consecutive days unless justification of the medical necessity for additional days is submitted and approved by the carrier/self-insured employer;

b. confirmatory consultation performed by the same physician on the same day as ventilation assist and management is included in the basic allowance of the ventilation assist and management;

c. follow-up consultations performed by the same physician on the same day as follow-up ventilation assist and management are included in the basic allowance of the ventilation assist;

d. pulmonary services performed:

i. by or under the direct supervision of a physician; and

ii. for the diagnosis and/or treatment of pulmonary symptoms or diseases;

e. pulmonary function studies;

f. reimbursement for the following procedures is included in the basic allowance of Spirometry when performed by the same physician on the same day:

i. maximum breathing capacity, maximal voluntary ventilation;



- ii. respiratory flow volume loop;
- iii. vital capacity, total; and
- iv. vital capacity, screening test: total capacity, with timed forced expiratory volume, and peak flow rate;
- g. reimbursement for Spirometry is included in the basic allowance of the following studies when performed by the same physician on the same day:
  - i. bronchospasm evaluation: spirometry before or after bronchodilator (aerosol or parenteral) or exercise; and
  - ii. prolonged postexposure evaluation of bronchospasm with multiple spirometric determinations after test dose of bronchodilator (aerosol only) or antigen, with spirometry;
  - h. reimbursement for carbon dioxide, expired gas determination by infrared analyzer, is included in the basic allowance of the specific pulmonary function test performed by the same physician on the same day;
  - i. pulmonary stress testing, simple or complex, only if a physician is present during the testing. Reimbursement for the following services is included in the basic allowance of pulmonary stress testing:
    - i. continuous blood pressure monitoring;
    - ii. expired gas measurements;
    - iii. maximal or submaximal treadmill or bicycle exercise;
    - iv. oximetry; and
    - v. 12 lead electrocardiogram;
  - j.i. pulmonary therapy and/or treatment, when performed in the office location:
    - (a). intermittent positive pressure breathing (IPPB) treatment, air or oxygen, with or without nebulized medication; and
    - (b). aerosol or vapor inhalations for sputum mobilization, bronchodilation, or sputum induction for diagnostic purposes;
      - (i). reimbursement for medications, supplies and heated aerosol is included in the basic allowance for the treatment;
    - k. reimbursement for pulmonary therapy and/or treatment is not to exceed five treatments of each type (i.e., IPPB and aerosol) procedure performed within a 30-day period. Reimbursement for pulmonary therapy and/or treatment is allowed in addition to the allowance of an office visit when performed by the same physician on the same day;
    - l.i. ventilation assist and management, when performed by the same physician on the same day:
      - (a). continuous positive airway pressure ventilation (CPAP), initiation and management; and

(b). continuous negative pressure ventilation (CNP), initiation and management;

ii. for ventilation assist and management, rendered in conjunction with Initial Critical Care, see Initial Critical Care. For ventilation assist and management rendered in conjunction with other initial services.

AUTHORITY NOTE: Promulgated in accordance with R.S. 23:1034.2.

HISTORICAL NOTE: Promulgated by the Department of Labor, Office of Workers' Compensation, LR 19:54 (January 1993), repromulgated LR 19:212 (February 1993), amended LR 20:1299 (November 1994).

#### **§4511. Noncovered Services**

A. Only those services specifically listed in the section of this manual entitled "Maximum Reimbursement Allowances" are covered. Charges billed under the code for unlisted services or equipment will be reviewed prior to any pricing. Charges for items under this code that were not pre-authorized will be disallowed. Noncovered professional services include but are not limited to:

1. any service considered investigational or experimental, such as membrane diffusion capacity;
2. services not ordered by a physician or administered under the direction of a physician or by qualified medical staff; and
3. services not consistent with the patient's diagnosis, treatment or respiratory problems.

B. No charge will be allowed for deliveries of equipment unless the point of delivery is more than 50 miles from the provider's place of business.

AUTHORITY NOTE: Promulgated in accordance with R.S. 23:1034.2.

HISTORICAL NOTE: Promulgated by the Department of Labor, Office of Workers' Compensation, LR 19:54 (January 1993), repromulgated LR 19:212 (February 1993), amended LR 20:1299 (November 1994).

#### **§§4513-4535. Reserved.**

#### **§4537. Maximum Reimbursement Allowance**

A. Maximum allowable reimbursement for compensable professional respiratory therapy services will be based upon the lesser of the provider's charge or the allowance indicated in the Office of Workers' Compensation administration's CPT code reimbursement manual listing of medical procedures.

B. Maximum allowable reimbursement for respiratory therapy supplies, equipment and related services will be the least of:

1. the provider's usual and customary fee;
2. a pre-negotiated amount between the provider and carrier/self-insured employer; or
3. the amount indicated in the maximum allowable reimbursement schedule.

#### **C. Respiratory Services Equipment**

LABOR AND EMPLOYMENT

State of Louisiana Office of Workers' Compensation Schedule of Maximum Allowances for Respiratory Services Equipment				
E0424	Stat comp gas O2 system, rental			\$455
E0425	Stat comp gas O2 system, purchase	\$4,550	\$3,413	
E0430	Port gas O2 system, purchase	\$2,150	\$1,613	
E0431	Port gas O2 system, rental			\$215
E0433	Portable liquid oxygen sys			\$67
E0434	Port liquid O2 system, rental			\$223
E0435	Port liquid O2 system, purchase	\$2,230	\$1,673	
E0439	Stat liquid O2 system, rental			\$455
E0440	Stat liquid O2 system, purchase	\$4,550	\$3,413	
E0441	O2 contents, gaseous, per unit	\$20		
E0442	O2 contents, liquid, per unit			
E0443	Port O2 contents, gaseous, unit	\$10		
E0444	Port O2 contents, liquid, unit	100.69		
E0450	Volume ventilator; stat/portable	B.R.	B.R.	\$1,750
E0455	O2 tent, excl croup/ped tents	B.R.		
E0457	Chest shell (cuirass)	\$721	\$540	\$72
E0459	Chest wrap	\$534	\$400	\$53
E0460	Neg pressure vent; port/statonary	\$9,053	\$6,790	\$905
E0461	Vol control vent noninv int			\$1,333
E0462	Rocking bed w//w/o side rails	\$3,057	\$2,293	\$306
E0463	Press supp vent invasive int			\$1,964
E0464	Press supp vent noninv int			\$2,132
E0470	RAD w/o backup non-inv intrfc			\$309
E0471	RAD w/backup non inv intrfc			\$773
E0472	RAD w backup invasive intrfc			\$773
E0480	Percussor, elect/pneum, home mod	\$670	\$503	\$67
E0481	Intrpulumry percuss vent sys	B.R.	B.R.	B.R.
E0482	Cough stimulating device			\$600
E0483	Chest compression gen system			\$1,485
E0484	Non-elec oscillatory pep dvc	\$52	\$39	\$5
E0485	Oral device/appliance prefab	B.R.	B.R.	B.R.
E0486	Oral device/appliance cusfab	B.R.	B.R.	B.R.
E0487	Electronic spirometer	B.R.	B.R.	B.R.
E0500	IPPB machine, w/built-in Nebuliz	\$1,152	\$864	\$115
E0550	Humidifier, extensive sup humid	\$526	\$394	\$53
E0555	Humidifier, glass/autoclav plast	B.R.		
E0560	Humidifier, supplemental humidi	\$212	\$159	\$22
E0565	Compressor, air power source	\$640	\$480	\$64
E0570	Nebulizer, w/compressor	\$207	\$155	\$21
E0572	Aerosol compressor adjust pr			\$53
E0574	Ultrasonic generator w svneb			\$56
E0575	Nebulizer; ultrasonic	\$1,078	\$809	\$108
E0580	Nebulizer, glass/autoclav plast			\$16
E0585	Nebulizer, w/compressor and heater	\$433	\$325	\$43
E0600	Suction pump, home model, port	\$491	\$368	\$50

State of Louisiana Office of Workers' Compensation Schedule of Maximum Allowances for Respiratory Services Equipment				
E0601	Cont airway pressure (CPAP) dev	\$1,172	\$879	\$117
E0605	Vaporizer, room type	\$29	\$23	\$3
E0606	Postural drainage board	\$241	\$180	\$24
E1353	Regulator			
E1354	Wheeled cart, port cyl/conc	B.R.	B.R.	B.R.
E1355	Stand/rack	B.R.		
E1356	Batt pack/cart, port conc	B.R.	B.R.	B.R.
E1357	Battery charger, port conc	B.R.	B.R.	B.R.
E1358	DC power adapter, port conc	B.R.	B.R.	B.R.
E1372	Immersion ext heater nebulizer	\$201	\$149	\$29
E1405	O2 and water vapor enriching system	B.R.		
E1406	O2 and water vapor enriching system	B.R.		

AUTHORITY NOTE: Promulgated in accordance with R.S. 23:1034.2.

HISTORICAL NOTE: Promulgated by the Department of Labor, Office of Workers' Compensation, LR 19:54 (January 1993), repromulgated LR 19:212 (February 1993), amended LR 20:1299 (November 1994), amended by the Workforce Commission, Office of Workers' Compensation, LR 39:1854 (July 2013).

### Chapter 47. Miscellaneous Claimant Expenses Reimbursement Schedule, Billing Instruction and Maintenance Procedures

Editor's Note: Other Sections applying to this Chapter can be found in Chapter 51.

§§4701-4731. Reserved.

§4733. Schedule of Maximum Allowances

A. General Guidelines

1. Maximum reimbursement allowances have been established for most of the services required by workers' compensation claimants. The maximum allowable reimbursement can generally be found in one of the following manuals:

- a. *CPT Code Reimbursement Manual*—this manual contains reimbursement allowances for services described by CPT-4 codes, i.e., dental, surgical, radiology, pathology, and medical procedures;
- b. pharmacy reimbursement manual;
- c. vision care services reimbursement manual;
- d. vocational rehabilitation services reimbursement manual;
- e. home and vehicle modification reimbursement manual;
- f. hospital reimbursement manual;
- g. hearing aid equipment reimbursement manual;
- h. respiratory services reimbursement manual;

- i. durable medical equipment reimbursement manual;
- j. nursing attendant care reimbursement manual;
- k. prosthetic and orthopedic equipment reimbursement manual;
- l. medical transportation reimbursement manual.

2. Each of the above manuals limits payment to the least of:

- a. the provider's usual and customary fee;
- b. a pre-negotiated amount between the provider and the carrier/self-insured employer; or
- c. the amount indicated in the maximum allowable reimbursement schedule.

B. Individual Consideration Items/Services. Many services considered "miscellaneous" in nature cannot be pre-determined and no maximum allowance can be scheduled. The primary method of cost control for these items is totally within the purview of the carrier/self-insured employer. It is logical for the carrier/self-insured employer to set a limit which can be approved without investigation or comparative pricing. Any charges above the carrier/self-

insured employer established parameter should be subject to comparative pricing review by the carrier/self-insured employer. Some of the items for which no reimbursement allowances have been established are:

- 1. pharmacy—nonprescription needs;
- 2. books for rehabilitation training;
- 3. room and board fees to obtain medical and nonmedical treatment; and
- 4. injections.

C. Statutory Reimbursement Limitations. Certain services are limited in reimbursement by statute. These are:

1. mileage expenses—reimbursement shall be at the same rate per mile as established by the state of Louisiana for reimbursement of state employees (R.S. 23:1203). The carrier/self-insured employer shall inform claimants of their right to reimbursement for mileage. The next page contains a Mileage Reimbursement Log for filing mileage expense;

2. burial expenses—reimbursement for burial expenses is limited by statute (R.S. 23:1210) to \$3,000.

LABOR AND EMPLOYMENT

D. Mileage Reimbursement Log

Mileage Reimbursement Log

Claimant \_\_\_\_\_ Social Security Number \_\_\_\_\_ Period Beginning \_\_\_\_\_ Period Ending \_\_\_\_\_

Table with 5 columns: Place Traveled (From, To), Date, Mileage, Total (\$). Includes a Totals row at the bottom.

Instructions for Completion of Form:

Claimant—enter your name.

Social Security Number—enter your Social Security number.

Period Beginning—enter first date of travel on this log.

Period Ending—enter last date of travel on this log.

Place Traveled From—enter the street address of starting point.

Place Traveled To—enter the street address of destination.

Date—enter date of travel.

Mileage—enter number of miles traveled.

Total (\$)—enter product of miles traveled times mileage reimbursement allowance (miles x cents per mile).

Totals—enter sum of Mileage column and the sum of Total (\$) column.

AUTHORITY NOTE: Promulgated in accordance with R.S. 23:1034.2.

HISTORICAL NOTE: Promulgated by the Department of Labor, Office of Workers' Compensation, LR 19:54 (January 1993), repromulgated LR 19:212 (February 1993), amended LR 20:1299 (November 1994).

§§4735-4743. Reserved.

Chapter 49. Vocational Rehabilitation Consultant Reimbursement Schedule, Billing Instruction and Maintenance Procedures

Editor's Note: Other Sections applying to this Chapter can be found in Chapter 51.

§§4901-4909. Reserved.

§4911. Covered Services

A. The carrier/self-insured employer authorizes private rehabilitation firms to provide professional services including consultation, assessment, and follow-up to assist claimants in returning to suitable gainful employment, as provided by R.S. 23:1226.

B. The professional service fee includes costs related to the rendering of professional services, i.e., clerical support, postage and the preparation of correspondence. No additional charges are allowed for the activities which constitute professional services.

C. Waiting time, mileage, and long distance phone calls are reimbursed separately.

AUTHORITY NOTE: Promulgated in accordance with R.S. 23:1034.2.

HISTORICAL NOTE: Promulgated by the Department of Labor, Office of Workers' Compensation, LR 19:54 (January 1993), repromulgated LR 19:212 (February 1993), amended LR 20:1299 (November 1994).

**§4913. Noncovered Services**

A. No duplicate payment will be made for medical reports prepared by physicians and submitted through the counselor. Such reports are requested from the treating physician by the counselor and payment for these reports is made by the carrier/self-insured employer.

B. No payment will be made for any activity after notification by the carrier/self-insured employer of case closure.

AUTHORITY NOTE: Promulgated in accordance with R.S. 23:1034.2.

HISTORICAL NOTE: Promulgated by the Department of Labor, Office of Workers' Compensation, LR 19:54 (January 1993), repromulgated LR 19:212 (February 1993), amended LR 20:1299 (November 1994).

**§4915. Schedule of Maximum Allowances**

A. This reimbursement schedule indicates maximum allowances which constitute payment in full for the services. No additional charge to the claimant is allowed. No charge shall be submitted to the carrier/self-insured employer before the service has been performed. All procedures require prior authorization.

Professional fee, per hour	\$80*
Travel time/wait time, per hour	\$80*
Mileage, per mile	**
Long distance calls	At Cost
Local calls	\$0.25

\*When appropriate, a pro rata billing of this amount should be made at the rate of \$1.3333 per minute. (i.e., 15 minutes should be billed as \$20.00; 20 minutes as \$26.67; 30 minutes as \$40.00; 40 minutes as \$53.33, etc.)

\*\*IRS Standard Mileage Rate in effect at the time services are rendered.

AUTHORITY NOTE: Promulgated in accordance with R.S. 23:1034.2.

HISTORICAL NOTE: Promulgated by the Department of Labor, Office of Workers' Compensation, LR 19:54 (January 1993), repromulgated LR 19:212 (February 1993), amended LR 20:1299 (November 1994).

**§4917. Billing Code Instructions**

A. For billing Vocational Rehabilitation Consultant Services, the following locally assigned HCPCS codes will be used.

Code	Description
X0710	Professional fee, per hour
X0720	Professional Fee (Travel Time/Wait Time), per hour
X0730	Mileage, per mile
X0740	Long Distance Calls
X0750	Local Calls

B. Additional codes may be assigned by the Office of Workers' Compensation as the need arises.

AUTHORITY NOTE: Promulgated in accordance with R.S. 23:1034.2.

HISTORICAL NOTE: Promulgated by the Department of Labor, Office of Workers' Compensation, LR 19:54 (January 1993), repromulgated LR 19:212 (February 1993), amended LR 20:1299 (November 1994).

**§§4919-4939. Reserved.**

**Chapter 51. Medical Reimbursement Schedule**

Editor's Note: The following Sections of this Chapter are applicable and shall be used for the Chapters in this Part governing reimbursement. These specific Chapters are: Chapter 25, Hospital Reimbursement; Chapter 29, Pharmacy; Chapter 31, Vision Care Services; Chapter 33, Hearing Aid Equipment and Services; Chapter 35, Nursing/Attendant Care and Home Health Services; Chapter 37, Home and Vehicle Modification; Chapter 39, Medical Transportation; Chapter 41, Durable Medical Equipment and Supplies; Chapter 43, Prosthetic and Orthopedic Equipment; Chapter 45, Respiratory Services; Chapter 47, Miscellaneous Claimant Expenses; Chapter 49, Vocational Rehabilitation Consultant; Chapter 51, Medical Reimbursement Schedule; and Chapter 53, Dental Care Services.

**§5101. Statement of Policy**

A. It is the intent of this reimbursement schedule to limit to the mean of the usual and customary charge all fees for medical services, supplies, and other non-medical services delivered to workers' compensation claimants, as authorized by law.

B. The law provides that an employer or compensation insurer owes to an injured worker 100 percent of the medical fees incurred in the treatment of work-related injuries or occupational diseases [hereinafter referred to as "illness(es)"].

1. It is therefore the policy of the Office of Workers' Compensation that medical bills for services should be sent to the carrier/self-insured employer for payment. Fees for covered services in excess of the amounts allowable under the terms of this schedule are not recoverable from the employer, insurer, or employee.

2. It is also deemed to be in the best interest of all of the parties in the system that fees for services reasonably performed and billed in accordance with the reimbursement schedule should be promptly paid. Not paying or formally contesting such bills by filing LDOL-WC-1008 (Disputed Claim for Compensation) with the Office of Workers' Compensation within 30 days of the date of receipt of the bill may subject the carrier/self-insured employer to penalties and attorneys' fees.

3. If claimant is receiving treatment for both compensable and noncompensable conditions only those services provided in treatment of compensable conditions should be listed on invoices submitted to the carrier/self-insured employer unless the noncompensable condition (e.g., hypertension, diabetes) has a direct bearing on the treatment of the compensable condition. In addition, payments from private payers for noncompensable conditions should not be listed on invoices submitted to the carrier/self-insured employer. If a provider reasonably does not know the workers' compensation status, or the workers' compensation insurer has denied coverage, the provider will not be penalized for not complying with this rule. Upon notification or knowledge of workers' compensation eligibility, the provider will comply with these regulations prospectively.

## LABOR AND EMPLOYMENT

4. Statements of charges shall be made in accordance with standard coding methodology as established by these rules, ICD-10-CM, ICD-10-PCS, HCPCS, CPT-4, CDT-1, NDAS coding manuals. Unbundling or fragmenting charges, duplicating or over-itemizing coding, or engaging in any other practice for the purpose of inflating bills or reimbursement is strictly prohibited. Services must be coded and charged in the manner guaranteeing the lowest charge applicable. Knowingly and willfully misrepresenting services provided to workers' compensation claimants is strictly prohibited.

5. Providers should take reasonable steps to ensure that only those services provided are billed to the carrier/self insured employer. Violation of this provision may subject provider/practitioner to mandatory audit of all charges.

6. Bills for a particular charge item may not be included in subsequent billings without clear indication that they have been previously billed.

7. These rules are to be used in conjunction with Chapter 27 rules on utilization review procedures.

8. Sales taxes and other state mandated taxes are required to be reimbursed in addition to other procedure, supplies or medical services.

**AUTHORITY NOTE:** Promulgated in accordance with R.S. 23:1034.2.

**HISTORICAL NOTE:** Promulgated by the Department of Labor, Office of Workers' Compensation, LR 19:54 (January 1993), repromulgated LR 19:212 (February 1993), amended LR 20:1299 (November 1994), amended by the Workforce Commission, Office of Workers' Compensation Administration, LR 40:375 (February 2014), LR 42:288 (February 2016).

### §5103. Introduction

A. This document is primarily intended to facilitate the establishment of the maximum allowable reimbursement for all physician, chiropractic, physical and occupational therapy, pharmacy, hospital, vision care, hearing aid equipment, nursing/attendant care and home health, home and vehicle modification, medical transportation, durable medical equipment, prosthetic, and orthopedic equipment, respiratory, miscellaneous claimant expenses, vocational rehabilitation and dental care services.

B. For an overview of the Workers' Compensation Program and all policies and procedure concerning treatment of compensable work related injuries and illnesses, please refer to the carrier/self-insured employer.

**AUTHORITY NOTE:** Promulgated in accordance with R.S. 23:1034.2.

**HISTORICAL NOTE:** Promulgated by the Department of Labor, Office of Workers' Compensation, LR 19:54 (January 1993), repromulgated LR 19:212 (February 1993), amended LR 20:1299 (November 1994).

### §5105. Verification of Coverage

A. The carrier/self-insured employer is responsible for 100 percent of the maximum allowable reimbursement rate for covered services rendered for treatment of compensable conditions. The claimant is not required to contribute a co-payment and does not have to meet any deductibles.

1. Prior to the provision of medical services, supplies, or other non-medical services the determination that the illness, injury, or condition, is work related must be made, and must be accomplished in the following manner:

a. carrier/self-insured employer should be contacted for verification of coverage/liability;

b. the name and title of the individual verifying coverage/liability must be recorded in the claimant's records;

c. denial of coverage/liability must be immediately communicated to the claimant.

2. Those procedures identified in this reimbursement schedule as noncovered are not billable to the claimant if rendered in treatment of compensable conditions unless the claimant is informed beforehand that he will be responsible for the charges.

3. In certain circumstances, the provider collects his fees from the claimant because he is unsure or unaware of the occupational nature of the injury or condition. If the provider decides to bill the workers' compensation carrier/self-insured employer after compensability has been established, he must, to the best of his knowledge, make certain that the claimant has not already filed for reimbursement. If the claimant has not filed, the provider should bill the carrier/self-insured employer and reimburse the claimant. To avoid duplicate billings, the provider should file for the claimant, billing the full amount; or, the claimant should bill the full amount himself.

B. For covered services, if there is a difference between the provider's billed amount and the Office of Workers' Compensation maximum allowable reimbursement, the claimant, employer and carrier cannot under any circumstances, be billed for the difference.

**AUTHORITY NOTE:** Promulgated in accordance with R.S. 23:1034.2.

**HISTORICAL NOTE:** Promulgated by the Department of Labor, Office of Workers' Compensation, LR 19:54 (January 1993), repromulgated LR 19:212 (February 1993), amended LR 20:1299 (November 1994).

### §5107. Other Payer Liabilities

A. Whenever a claimant is eligible for Medicare or payment from another third party payer and is also eligible for workers' compensation medical benefits, the carrier/self-insured employer is always the primary payer, the payer of first resort. Services related to compensable conditions should be billed to the carrier/self-insured employer before attempting to collect from the third party payer.

B. If a claimant is receiving treatment for both compensable and noncompensable medical conditions, only those services provided in treatment of compensable conditions should be listed on claims and invoices submitted to the carrier/self-insured employer. In addition, payments from private payers for noncompensable conditions should not be listed on invoices submitted to the carrier/self-insured employer.

C. Charges for noncompensable conditions are collectible by the provider from any other third party payer,

subject to the limitations and exclusions contained in the third payer's policy.

**AUTHORITY NOTE:** Promulgated in accordance with R.S. 23:1034.2.

**HISTORICAL NOTE:** Promulgated by the Department of Labor, Office of Workers' Compensation, LR 19:54 (January 1993), repromulgated LR 19:212 (February 1993), amended LR 20:1299 (November 1994).

### §5109. Prior Authorization

A. The Louisiana Workers' Compensation Statutes (R.S. 23:1142) establishes a monetary limit for nonemergency medical care. The statute further provides significant penalties for a carrier/self-insured employer's arbitrary and capricious refusal to approve necessary care beyond that limit. (See Chapter 27 Utilization Review Procedures, §2715.A and B). In addition to all other rules and procedures, the provider or practitioner who provide care under the "medical emergency" exception must demonstrate that it was a "medical emergency" as outlined in the Utilization Review Procedures, cited above. For additional instructions, please refer to the respective section of the schedule.

**AUTHORITY NOTE:** Promulgated in accordance with R.S. 23:1034.2.

**HISTORICAL NOTE:** Promulgated by the Department of Labor, Office of Workers' Compensation, LR 19:54 (January 1993), repromulgated LR 19:212 (February 1993), amended LR 20:1299 (November 1994).

Editor's Note: In addition, the following Sections of this Chapter are applicable and shall be used for the other chapters in this Part governing reimbursement. These specific Chapters are: Chapter 31, Vision Care Services; Chapter 33, Hearing Aid Equipment and Services; Chapter 35, Nursing Attendant Care and Home Health Services; Chapter 39, Medical Transportation; Chapter 41, Durable Medical Equipment and Supplies; Chapter 43, Prosthetic and Orthopedic Equipment; Chapter 45, Respiratory Services; Chapter 47, Miscellaneous Claimant Expenses; and Chapter 49, Vocational Rehabilitation Consultant.

### §5111. Billing Instructions

A. The HCFA 1500 Form is to be used by health care providers except dentist, pharmacy, hospital (unless otherwise stated), and for home and vehicle modifications for billing services provided to workers' compensation claimant. Do not use any other form. A sample HCFA 1500 Claim Form and detailed instruction for proper completion of the form follows.

B. Bills for services rendered should be sent directly to the party responsible for reimbursement. Please do not send your bills directly to the Office of Workers' Compensation as this will delay your payments.

C. Instructions for use of HCFA 1500 Form:

1. provide the claimant's full name and address;
2. indicate the Social Security number; this cuts down on errors and helps correlate the billing to the appropriate file;
3. identify correct date of injury, if possible;

4. complete name and address of the employer, not just an individual's name;
5. name of the insurance carrier;
6. the attending physician should indicate the date the claimant's disability should begin;
7. the attending physician should list all diagnoses and claimant's complaints;
8. the date of the visit, the service(s) or procedure(s) performed and charges;
9. provider's complete name and address;
10. provider's identification number, i.e., tax identification number (TIN) or Social Security number.

**AUTHORITY NOTE:** Promulgated in accordance with R.S. 23:1034.2.

**HISTORICAL NOTE:** Promulgated by the Department of Labor, Office of Workers' Compensation, LR 19:54 (January 1993), repromulgated LR 19:212 (February 1993), amended LR 20:1299 (November 1994).

### §5113. Coding System

A. **Diagnosis Coding.** *The International Classification of Diseases, Tenth Revision* (ICD-10-CM) is the basis of diagnosis coding. These are the disease codes in the international classification, tenth revision, clinical modifications published by the U.S. Department of Health and Human Resources.

#### B. Helpful Hints for Diagnosis Coding

1. To ensure accurate payment, always report the primary diagnosis code on the claim form.
2. Each diagnosis code should be reported when services for multiple diagnosis are filed on the same claim form.
3. All digits of the appropriate ICD-10-CM code(s) should be reported.
4. The date of accident should always be reported if the ICD-10-CM code is for an accident diagnosis.
5. It is important to provide a complete description of the diagnosis if an appropriate ICD-10-CM code cannot be located.

C. **Procedure Codes.** HCPCS (pronounced "hick picks") is the acronym for the HCFA (Health Care Financing Administration) common coding system. This system is a uniform method for health care providers and medical suppliers to code professional services, procedures and supplies. HCPCS contains three unique coding systems, each called a level and numbered I, II and III respectively.

1. **Level I.** Level I is the American Medical Association's CPT (Physicians' Current Procedural Terminology) which is developed and maintained by the AMA. The CPT is a listing of descriptive terms and identifying codes for reporting medical services and procedures performed by physicians and are used for processing claims. Each procedure or service is identified with a five digit code.

2. Level II. HCPCS National Level II codes are alphanumeric codes which start with a letter followed by four numbers. These codes can be used in addition to CPT codes when services are provided at the same time or during the same visit. All services, procedures, supplies, materials and injections should be properly documented in the medical record.

3. Level III. This level is often used to describe new services, supplies or materials or to report procedures and services which have been deleted from CPT. These level III codes are not to be used for Workers' Compensation claims.

AUTHORITY NOTE: Promulgated in accordance with R.S. 23:1034.2.

HISTORICAL NOTE: Promulgated by the Department of Labor, Office of Workers' Compensation, LR 19:54 (January 1993), repromulgated LR 19:212 (February 1993), amended LR 20:1299 (November 1994), amended by the Workforce Commission, Office of Workers' Compensation Administration, LR 42:288 (February 2016).

NOTE: The following Sections are to be used for Chapter 51 only.

## §5115. Surgery Guidelines

### A. General Guidelines

1. Global Surgery. The reimbursement allowances for surgical procedures are based on a global reimbursement concept that covers performing the basic service and the normal range of care required before and after surgery. The global reimbursement includes:

a. the initial evaluation or consultation by a surgeon will be paid separately. The pre-operative policy will include all pre-operative visits, in or out the hospital, by the surgeon beginning the day before the surgery;

b. local anesthesia, such as infiltration, digital or topical anesthesia;

c. normal, uncomplicated follow-up care for the time periods indicated in the follow-up days column to the right of each procedure code. The number in that column establishes the days during which no additional reimbursement is allowed for the usual care provided following surgery, absent complications or unusual circumstances. Follow-up days are specified by procedures. The day of surgery is day one when counting follow-up days;

d. the global fee will include services such as dressing changes, local incisional care, removal of operative packs, removal of cutaneous sutures, staples, lines, wires, tubes, drains, casts and splints; insertion, irrigation and removal of urinary catheters, routine peripheral intravenous lines nasogastric and rectal tubes, and change and removal of tracheostomy tubes.

2. Follow-Up Care for Diagnostic Procedures. Follow-up care for diagnostic procedures, e.g., endoscopy, arthroscopy, injections procedures for radiography; includes only care that is related to the recovery from the diagnostic procedure itself. Care of the condition for which the diagnostic procedure was performed or of other concomitant

condition is not included and may be charged for in accordance with the services provided.

3. Follow-Up Care for Therapeutic Surgical Procedures. Follow-up care for therapeutic surgical procedures includes only care that is usually part of the surgical procedure. Complications, exacerbations, recurrence, or the presence of other diseases or injuries requiring additional services concurrent with the procedure(s) or during the listed period of normal follow-up care may warrant additional charges. The workers' compensation carrier is responsible only for charges related to the compensable injury or illness unless the noncompensable condition has a direct bearing on the treatment of the compensable condition.

4. Additional Surgical Procedure(s). When an additional surgical procedure(s) is carried out within the listed period of follow-up care for a previous surgery, the follow-up periods will continue concurrently to other normal terminations.

5. Operating Microscope. Additional reimbursement for the use of an operating microscope (excluding loupes or other magnifying devices) will be allowed when the listed code does not state the use of the microscope is inherent in the procedure.

6. Unique Techniques. A surgeon is not entitled to an extra fee for a unique technique. It is inappropriate to use Modifier-22 unless the procedure is significantly more difficult than indicated by the description of the code.

7. Surgical Destruction. Surgical destruction is part of a surgical procedure, and different methods of destruction are not ordinarily listed separately unless the technique substantially alters the standard management of a problem or condition. Exceptions under special circumstances are provided for by separate code numbers.

8. Incidental Procedure(s). An additional charge for an incidental procedure (e.g., incidental appendectomy, incidental scar excisions, puncture of ovarian cysts, simple lysis of adhesions, simple repair of hiatal hernia, etc.) is not customary and does not warrant additional reimbursement.

9. Endoscopic Procedures. When multiple endoscopic procedures are performed, the major procedure is reimbursed at 100 percent. If a secondary procedure is performed through the same opening/orifice, 50 percent is allowable as a multiple procedure. However, diagnostic procedures during the same session and entry site are incidental to the major procedure, which is coded per the deepest penetration. Generally, no payment will be made for a visit on the same day in addition to the endoscopic procedure unless documented, separately identifiable service is furnished.

10. Biopsy Procedures. A biopsy of the skin and another surgical procedure performed on the same lesion on the same day must be billed as one procedure.

11. Repair of Nerves, Blood Vessels, and Tendons with Wound Repairs. The repair of nerves, blood vessels, and tendons is usually reported under the appropriate system. The repair of associated wounds is included in the primary



procedure unless it qualifies as a complex wound, in which case Modifier-51 may be applied. Simple exploration of nerves, blood vessels, and tendons exposed in an open wound is also considered part of the essential treatment of the wound closure and is not a separate procedure unless appreciable dissection is required.

12. Suture Removal. Billing for suture removal by the operating surgeon is not appropriate as this is considered part of the global fee.

13. Joint Manipulation under Anesthesia. There is no charge for manipulation of a joint under anesthesia when it is preceded or followed by a surgical procedure on that same day by that surgeon or associate. However, when manipulation of a joint is the scheduled procedure and it indicates additional procedures are necessary and appropriate, 50 percent of the manipulation may be allowed.

14. Supplies and Materials. Supplies and materials provided by the physician, e.g., sterile trays/drugs, over and above those usually included with the office visit may be listed separately using CPT Code 99070. These supplies and materials over \$50 will be reimbursed at invoice cost plus 20 percent. Specialized supplies and DME may require a copy of the invoice be sent to the C/SIE.

15. Plastic and Metallic Implants. Plastic and metallic implants or non-autogenous graft materials supplied by the physician are to be reimbursed at invoice cost plus 20 percent. An invoice with the cost of the material must be submitted to the C/SIE with the bill.

16. Aspirations and Injections. Puncture of a cavity of joint for aspiration followed by an injection of a therapeutic agent is one procedure and should be billed as such.

17. Assistant-at-Surgery. An assistant-at-surgery is an individual who has the necessary qualifications to participate in a particular operation and actively assist in performing the surgery.

a. A physician who assists at surgery may be reimbursed as a surgical assistant. The surgical assistant must bill separately from the primary physician. Modifier-80 should be used. Reimbursement should be 20 percent of the allowable reimbursement amount for the procedure(s). The assistant surgeon's name should be listed on the operative report.

b. Payment for physician assistant, nurse practitioner or surgical technicians will be made only to the employer not to the individual. Reimbursement is limited to 65 percent of the allowable amount for M.D. assistant surgeons.

c. Reimbursement for assistants at surgery shall be based on medical necessity. If a procedure usually does not require the use of an assistant, documentation of medical necessity shall be submitted with the claim form.

18. Operative Reports. An operative report must be submitted to the carrier before reimbursement can be made for the surgeon's or assistant surgeon's services.

19. Needle Procedures. Needle procedures (lumbar puncture, thoracentesis, jugular or femoral taps, etc.) should be billed in addition to the medical care on the same day.

20. Therapeutic Procedures. Therapeutic procedures (injecting into cavities, nerve blocks, etc.) (20550-20610; 64400-64450) may be billed in addition to the medical care for a new patient. (Use appropriate level of service plus injection.) In follow-up cases for additional therapeutic injections and/or aspirations, an office visit is only indicated if it is necessary to re-evaluate the patient. In this case, a minimal visit may be listed in addition to the injection. Documentation supporting the office visit charge must be submitted with the bill to the carrier/SIE. Reimbursement for therapeutic injections will be made according to the multiple procedure rule. Trigger point injection is considered one procedure and reimbursed as such regardless of the number of injection sites.

21. Anesthesia by Surgeon. In certain circumstances it may be appropriate for the attending surgeon to provide regional or general anesthesia. Anesthesia by the surgeon is considered to be more than local or digital anesthesia. Identify this service by adding the Modifier-47 to the surgical code. Only base anesthesia units are allowed (See Anesthesia, §5117).

#### B. Multiple Procedures

1. Multiple Procedure Reimbursement Rule. When more than one procedure is performed during the same operative session at the same operative site and also multiple procedures performed during the same operative session through multiple incisions for the same operative procedure the following reimbursement applies:

- a. 100 percent for the primary procedure;
- b. 60 percent for the second procedure;
- c. 40 percent for the third procedure;
- d. 25 percent for fourth and fifth procedures; and
- e. each procedure after the fifth procedure will be paid by special report.

2. Bilateral Procedure Reimbursement Rule. When bilateral procedures are performed that require preparation of separate operative sites, e.g., bilateral carpal tunnel, the second (or bilateral) site will be reimbursed as follows:

- a. 75 percent value for the primary procedure at the remote site;
- b. 60 percent for the second procedure at the remote site;
- c. 40 percent for the third procedure at the remote site; and
- d. 25 percent for fourth and fifth procedures at the remote site.

3. Multiple Procedure Reimbursement. When multiple surgical procedures are performed in different areas of the body during the same operative sessions and the procedures are unrelated (i.e., abdominal hernia repair and a knee arthroscopy), the multiple procedure reimbursement rule will

## LABOR AND EMPLOYMENT

apply independently to each area. Modifier-51 must be added.

### C. Burns, Local Treatment

#### 1. Degree of Burns

a. Code 16000 must be used when billing for treatment of first degree burns when no more than local treatment of burned surfaces is required.

b. Codes 16010-16030 must be used when billing for treatment of second and third degree burns only.

c. The claim form must be accompanied by a report substantiating the services performed.

d. Major debridement of foreign bodies, grease, epidermis, or necrotic tissue may be billed separately under Codes 11000-11001. Modifier-51 does not apply.

e. In order to identify accurately the proper procedure code and substantiate the descriptor for billing, the exact percentage of the body surface involved and the degree of the burn must be specified on the claim form submitted or by attaching a special report.

f. The following definitions apply to Codes 16010-16030.

*Small*—less than 9 percent of the body area.

*Medium*—9-18 percent of the body area.

*Large*—greater than 18 percent of the body area.

g. Claims submitted without specification of the degree of burn and exact percentage of body area involved must be returned to the physician for this additional information.

h. Hospital visits, emergency room visits, or critical care visits provided by the same physician on the same day as the application of burn dressings will be reimbursed as a single procedure at the highest level of service, except in case of an asterisk.

### D. Nerve Blocks

#### 1. Diagnostic or Therapeutic

a. When a nerve block is performed for diagnostic or therapeutic purposes, the appropriate procedure code must be billed (62274-62279 or 64400-64530). It is inappropriate to use base and/or time units even when performed by an anesthesiologist.

b. Medications such as steroid, pain medication, etc., may be separately billed using Code 99070.

i. The name of the medication(s), dosage, and volume must be identified.

ii. Medication will be reimbursed at a reasonable cost.

#### 2. Anesthetic

a. When a nerve block for anesthesia is provided by the operating room surgeon, the procedure codes listed in §5117, Anesthesia, must be followed.

### E. Surgery Modifiers

1. Modifier codes may be used by providers to identify procedures or services that are modified due to specific circumstances.

2. Modifiers listed in the CPT must be added to the procedure code when the service or procedure has been altered from the basic procedure described by the descriptor.

3. When Modifier-22 is used to report an unusual service, a report explaining the medical necessity of the situation must be submitted with the claim to the C/SIE. It is not appropriate to use Modifier-22 for routine billing.

4. The use of modifiers does not imply or guarantee that a provider will receive reimbursement as billed. Reimbursement for modified services or procedures must be based on documentation of medical necessity and must be determined on a case by case basis.

F. Starred Procedures (starred in CPT book). Certain small surgical services involve a readily identifiable surgical procedure but include variable pre- and post-operative services (e.g., incision and drainage of an abscess, injection of a tendon sheath, manipulation of a joint under anesthesia). Because of the indefinite pre- and post-operative services, the usual "package" concept of surgical services cannot be applied. These procedures are identified in the CPT by a star (\*) following the procedure code number.

AUTHORITY NOTE: Promulgated in accordance with R.S. 23:1034.2.

HISTORICAL NOTE: Promulgated by the Department of Labor, Office of Workers' Compensation, LR 19:54 (January 1993), repromulgated LR 19:212 (February 1993), amended LR 20:1299 (November 1994).

### §5117. Anesthesia

A. General. The total anesthesia allowance is calculated by adding the basic value units, time value units, plus any applicable modifier unit values and/or unusual qualifying circumstances units and multiplying the sum by a dollar amount allowed per unit.

1. Basic Units. A basic unit is listed for most procedures. The allowable basic units are shown in the following schedule. When multiple surgical procedures are performed during the same period of anesthesia, only the greater basic unit allowance of the various surgical procedures will be used as the base. The basic value for each procedure includes pre- and post-operative visits, administration of fluids and/or blood incident to the anesthesia care and interpretation of noninvasive monitoring (EKG, temperature, blood pressure, oximetry capnography and mass spectrometry). When multiple surgical procedures are performed during the same period of anesthesia, only the highest base unit allowance of the various surgical procedures will be used.

2. Time Units. Time begins when the anesthesiologist begins to prepare the patient anesthesia care in the operating room or in a equivalent area. Time ends when anesthesiologist is no longer in personal attendance, that is, when the patient may be safely placed under postoperative supervision. The anesthesia time units will be calculated in

15-minute intervals, or portions thereof, equaling one time unit. In each instance, five minutes or greater is considered a significant portion of a time unit. No additional time units are allowed for recovery room time and monitoring.

3.a. **Modifier Units.** Physical status modifiers are represented by the letter "P" followed by a single digit defined below.

i.	Healthy Patient	0
ii.	Patient with mild systemic disease	0
iii.	Patient with severe systemic disease	1
iv.	Patient with severe systemic disease threat to life	2
v.	A moribund patient who is not expected to survive without the operation	3
vi.	A declared brain-dead patient whose organs are being removed for donor purposes	0
The above six levels are consistent with the American Society of Anesthesiologist (ASA) ranking of patient physical status.		
Example: 00100-P1		

4. **Qualifying circumstances warrant additional value due to unusual events.** The following list of CPT-4 codes and the corresponding anesthesia unit values may be listed if appropriate. More than one code may be necessary. The unit value listed is added to the existing anesthesia base units.

CPT-4		Units
99100	Anesthesia for patient of extreme age, under one year and over 70	1
99116	Anesthesia complicated by utilization of total body hypothermia	5
99135	Anesthesia complicated by utilization of controlled hypotension	5
99140	Anesthesia complicated by emergency conditions (specify)	2
(An emergency is defined as existing when delay in treatment of a patient would lead to a significant increase in the threat to life or body part.)		

5. Any procedure around the head, neck or shoulder girdle requiring field avoidance or any other procedure requiring a position other than supine or lithotomy, has a basic value of 5.0 units regardless of any lesser value assigned to such procedure. A medical report must be attached to document the special unit.

6. **Unlisted Service or Procedure.** When an unlisted service or procedure is provided, the value should be substantiated "by report." These services are shown in this schedule as "BR."

7. **Procedures Listed without Specified Unit Values.** "BR" in the value column indicates that the value of this service is to be determined "by report" because the service is too unusual or variable to be assigned a unit value.

8. **Monitored Anesthesia Care.** Monitored anesthesia care occurs when the attending physician requests that an anesthesiologist be present during a procedure. This may be to insure compliance with accepted procedures of the facility. Monitored Anesthesia Care includes pre-anesthesia exam and evaluation of the patient. The anesthesiologist must participate or provide medical direction for the plan of care. The anesthesiologist, resident, or nurse anesthetist must be in continuous physical presence and provide diagnosis and treatment of emergencies. This will also include

noninvasive monitoring of cardiocirculatory and respiratory systems with administration of oxygen and/or intravenous administration of medications. Reimbursement will be the same as if general anesthesia had been administered (time units + base units).

9. **More Than One Anesthesiologist.** When it is necessary to have a second anesthesiologist, the necessity should be substantiated by report "BR." It is recommended that the second anesthesiologist receive 5 base units + time units (calculation of total anesthesia value).

10. **Amount Payable**

a. The amount payable for anesthesia services will be the lesser of the actual charge or \$50 times the total allowed units as determined by this schedule and the above guidance.

b. The total anesthesia allowance is calculated by adding the basic unit value, the number of time units, plus any applicable modifier and/or unusual circumstance units and multiplying the sum by the \$50 allowed per unit.

c. When non-anesthetic procedures are performed by anesthesiologist, they should use the surgical or medical code and fee established for that code. Anesthesia units and conversion factors are to be used only when the primary purpose of the service is to anesthetize the patient so that the surgical procedure can be performed.

d. Trigger point injection is considered one procedure and is reimbursed as such regardless of the number of injection sites.

**B. Reimbursement Guidelines for Anesthesia Services.** Anesthesia services may be billed for any one of the three following circumstances.

1. An anesthesiologist provides total and individual anesthesia service.

2. An anesthesiologist directs a CRNA.

3. Anesthesia provided by a CRNA working independent of an anesthesiologist's supervision is covered under all the following conditions.

a. The service falls within the CRNA's scope of practice and scope of license as defined by law.

b. The service is reasonable and medically necessary.

c. The service is supervised by a licensed health care provider who has prescriptive authority.

d. The service is provided under one of the following conditions:

i. in accordance with the clinical privileges individually granted by the hospital or other health care organization;

ii. the doctor performing the procedure requiring the service specifically requests the service of a CRNA;

iii. the patient requiring the service specifically requests the service of a CRNA;

iv. the services are provided by a CRNA in connection with a medical emergency; or

v. no anesthesiologist is on staff or an anesthesiologist is unable to provide the service.

e. Payment for covered anesthesia services provided by a CRNA will be limited to the lesser of the actual charge or 80 percent of the medical reimbursement guideline total anesthesia value. Use Modifier –QZ.

f. Where a single anesthesia procedure involves both a physician medical direction service and the service of the medically directed CRNA, the payment amount for the service of each is 50 percent of the allowance otherwise recognized had the service been furnished by the anesthesiologist alone.

i. Use Modifier –QX if medical direction by physician.

ii. Use Modifier –QY if medical direction for one CRNA by anesthesiologist.

iii. Reimbursement shall not be made to either the anesthesiologist or the CRNA until the insurer has received and reviewed the bill and the anesthesia report from both providers.

iv. Reimbursement shall never exceed 100 percent of the maximum amount an anesthesiologist would have been allowed under the Medical Fee Schedule Allowance had the anesthesiologist or physician alone performed the services.

v. Medical supervision, as opposed to medical direction, occurs when the anesthesiologist is involved in furnishing more than four procedures concurrently or is performing other services while directing the concurrent procedures. No additional reimbursement shall be made for general supervisory services rendered by the anesthesiologist or other physician.

**AUTHORITY NOTE:** Promulgated in accordance with R.S. 23:1034.2.

**HISTORICAL NOTE:** Promulgated by the Department of Labor, Office of Workers' Compensation, LR 19:54 (January 1993), repromulgated LR 19:212 (February 1993), amended LR 20:1299 (November 1994), amended by the Workforce Commission, Office of Workers' Compensation Administration, LR 47:606 (May 2021).

**Editor's Note:** The following Sections apply to all the schedules mentioned in the beginning of Chapter 51: §§5119, 5121, 5123, 5145, 5147, 5149, and 5153.

**§5119. Deposition/Witness Fee Limitation**

A. Any health care provider who gives deposition shall be allowed a witness fee. Procedure Code 99075 must be used to bill for a deposition. Reimbursement for a deposition should be a specific amount mutually agreed upon and in writing, in advance of the event. Fees may be at an hourly rate or a flat rate. Disputes over these fees will be resolved in the same manner and subject to the same procedures as established for dispute resolution of claims for workers' compensation benefits.

**AUTHORITY NOTE:** Promulgated in accordance with R.S. 23:1034.2.

**HISTORICAL NOTE:** Promulgated by the Department of Labor, Office of Workers' Compensation, LR 19:54 (January 1993), repromulgated LR 19:212 (February 1993), amended LR 20:1299 (November 1994).

**§5121. Missed Appointments**

A. The provider shall not receive payment for a missed appointment unless the appointment was arranged by the carrier or the employer. If the carrier or employer fails to cancel the appointment not less than 72 hours prior to the time of the appointment and the provider is unable to arrange for a substitute appointment for that time, the provider may bill the carrier for the missed appointment.

**AUTHORITY NOTE:** Promulgated in accordance with R.S. 23:1034.2.

**HISTORICAL NOTE:** Promulgated by the Department of Labor, Office of Workers' Compensation, LR 19:54 (January 1993), repromulgated LR 19:212 (February 1993), amended LR 20:1299 (November 1994).

**§5123. Copies of Records and Reports**

A. Health care providers must submit copies of records and reports to carriers, employers, claimants or their attorney and the Office of Workers' Compensation Administration upon request. Providers can facilitate the timely processing of claims and payment for services by submitting appropriate documentation to the carrier/self-insured employer when requested.

B. Health care providers are entitled to recover a reasonable amount, not to exceed \$1 per page, to cover the cost of copying documents which have been requested by the carrier.

1. Certain procedure code descriptors require the submission of records and/or reports with the claim form. There is no reimbursement of copy charges to the provider for these required records and reports.

2. Documentation which is submitted by the provider, but was not specifically requested by the carrier, is not allowed a copy charge.

C. Health care providers must furnish an injured employee copies of his records and reports at the same time as copies are being furnished to the employer or carrier, at no expense to the employee. If additional copies are requested by claimant or his attorney, the copy charge to the employee or his attorney may not exceed \$0.50 per page.

D. Health care providers may charge the actual direct cost of copying X-rays, microfilm or other nonpaper records.

E. The OWCA may charge the actual cost of reproducing records which is established at \$0.25 per page and must be paid in advance.

F. A health care provider may not charge a separate fee for medical reports that are required to substantiate the medical necessity of a service.

G. CPT Code 99080 is not to be used to complete required workers' compensation forms or to complete required documentation to substantiate medical necessity. CPT Code 99080 is not to be used for signing affidavits or certifying medical records forms. CPT Code 99080 is

appropriate for billing of a special report such as independent medical examination report.

**AUTHORITY NOTE:** Promulgated in accordance with R.S. 23:1034.2., 1125, 1127 and 1310.12.

**HISTORICAL NOTE:** Promulgated by the Department of Labor, Office of Workers' Compensation, LR 19:54 (January 1993), repromulgated LR 19:212 (February 1993), amended LR 20:1299 (November 1994).

### §5125. Special Instructions

#### A. Procedure Codes Not Listed in Rules

1. If a procedure is performed which is not listed in the maximum reimbursement allowance, the health care provider must use an appropriate CPT code descriptor. The provider must submit a narrative report to the carrier to explain why it was medically necessary to use a particular procedure code or descriptor not contained in the maximum reimbursement allowance. The codes used in this schedule are 1994 CPT codes.

2. The CPT contains codes for unlisted procedures which end in "99." These codes should only be used when there is no procedure code which accurately describes the service rendered. A special report is required as these services are reimbursed by report.

3. Services must be coded with valid five digit procedure codes.

#### B. Modifiers

1. Modifier codes must be used by providers to identify procedures or services that are modified due to specific circumstances.

2. Modifiers listed in the CPT must be added to the procedure code when the service or procedure has been altered from the basic procedure described by the descriptor.

3. When Modifier-22 is used to report an unusual service, a report explaining the medical necessity of the situation must be submitted with the claim to the carrier. It is not appropriate to use Modifier-22 for routine billing.

4. The use of modifiers does not imply or guarantee that a provider will receive reimbursement as billed. Reimbursement for modified services or procedures must be based on documentation of medical necessity and must be determined on a case by case basis.

5. The modifier 95 appended to a code indicates it was performed by telemedicine/telehealth methods. Services should be reimbursed the same amount as the exact same codes without the modifier as long as the Emergency Rule exist. If carrier requires a Place of Service (POS) code for telemedicine/telehealth, code 02 may be used.

#### C. By Report (BR)

1. BR refers to the method by which the reimbursement for a procedure is determined by the carrier when a service or procedure is performed by the provider that does not have an established maximum reimbursement allowance.

2. Reimbursement for procedure codes listed as BR must be determined by the carrier based on documentation which is submitted to the carrier by the provider in a special report attached to the claim form. Information in this report must include, as appropriate:

- a. the pertinent history and physical findings;
- b. diagnostic tests and interpretation;
- c. therapeutic procedures;
- d. treatment for concurrent medical conditions;
- e. the final diagnosis/diagnoses;
- f. identification of, or an estimate of the time required for follow-up care;
- g. summary of treatment plan;
- h. copies of operative reports, consultation reports, progress notes, office notes or other applicable documentation;
- i. description of equipment necessary to provide the service.

3. Reimbursement by the carrier of BR procedures should be based upon the following:

- a. review of the submitted documentation;
- b. recommendation of the C/SIE's medical consultant;
- c. the C/SIE's review of the prevailing charges for like procedures based upon data which is specific for Louisiana charges.

4. Bundled Code. These codes are marked BR, and are not payable because the service is included in the payment for other services.

**D. Pathology.** If no indication is given in the fee schedule to differentiate between professional and technical components for the MFA, the standard would be 15 percent of the total allocated for the technical component and 85 percent for the professional component.

**E. Adjunct of Subsidiary Codes.** Certain codes, by the nature of their description have already been reduced, as they are never to be billed as primary procedures. These codes should be reimbursed at the listed value when billed with other procedures.

#### F. Dispensing Physician Services

1. Reimbursement to a physician for dispensing medications, drugs or chemicals is limited to physicians who are licensed through the State Board of Medical Examiners for dispensing such.

2. Payments shall be made in accordance with the Pharmacy Reimbursement Schedule, Chapter 29.

**AUTHORITY NOTE:** Promulgated in accordance with R.S. 23:1034.2.

**HISTORICAL NOTE:** Promulgated by the Department of Labor, Office of Workers' Compensation, LR 19:54 (January 1993), repromulgated LR 19:212 (February 1993), amended LR 20:1299 (November 1994), amended by the Louisiana Workforce

## LABOR AND EMPLOYMENT

Commission, Office of Workers' Compensation Administration, LR 46:1400 (October 2020).

### §5127. Physical Medicine

#### A. Practicing Physical and Occupational Therapists

1. To bill for physical therapist and/or occupational therapist services under workers' compensation, a practicing therapist must be:

a. currently licensed in the state of Louisiana as a physical therapist or as an occupational therapist;

b. if billing for physical or occupational therapy procedures, you must provide your physical therapist or occupational therapist license number. These procedures will not be reimbursed unless a current Louisiana license number is provided;

c. services must be billed using the appropriate national CPT codes as listed in this manual.

2. The following criteria must be met for therapy to qualify for reimbursement:

a. the patient's condition must have the potential for restoration of function;

b. the therapy must be specific for the improvement of the patient's condition;

c. the therapy must be provided under a current, written plan of care which is approved by a physician and substantiated in the office notes.

3. Upon request, physicians must submit to carriers documentation substantiating the medical necessity of therapies ordered.

#### B. Plan of Care

1. On the initial visit, a therapist must evaluate the patient's therapy needs and develop a written plan of care based upon the assessment of the patient's level of function and the physician's orders.

2. Plan of Care Content. At a minimum, the plan of care should contain:

a. the potential degree of restoration and measurable goals;

b. the specific therapies to be provided including the frequency of each treatment;

c. the estimated duration for the therapeutic regimen.

#### 3. Plan of Care Review

a. The therapist must review each plan of care at least every 30 days and make necessary revisions.

b. Physical and occupational therapy services required in excess of 45 days from onset of evaluation for treatment shall require evidence in writing as to the necessity for continued therapy. Thereafter, evidence in writing to the necessity for continued physical therapy shall be required every 30 days.

#### C. Assessment

1. Billing. The initial, written assessment developed by the therapist must be reported to the carrier using procedure code, 97001 or 97003.

#### 2. Reimbursement

a. Only one initial assessment per injury may be reimbursed. Reimbursement for the use of additional initial assessment time is not allowed.

b. Reimbursement for reassessment shall be recommended only once in a seven day period. Reassessment for established patients shall be billed under 97002 or 97004.

c. Assessment of the patient's status includes assessment of the neuromuscular system. Therefore, reimbursement must not be made for neuromuscular testing codes, extremity testing codes and/or range of motion codes except for those testing procedures identified by the following code: 97535 or 97755.

#### D. Modalities and Procedures

1. Body Areas. Under workers' compensation, the following two body areas, or any portions thereof, are recognized for the provision of modalities and procedures:

a. the trunk—the entire body including the spine, excluding the head and limbs (syn: torso);

b. any two extremities:

i. an upper extremity is an upper limb, including the shoulder, upper arm, elbow, forearm, wrist and hand;

ii. a lower extremity is a lower limb, including the hip, thigh, knee, leg, ankle and foot.

#### 2. Reimbursement

a. No more than one visit per day for the purpose of therapy may be reimbursed.

b. The carrier should compare the billing with the plan of care to ensure that only the services that are itemized in the plan of care are reimbursed.

c. Since the Hubbard Tank or Therapeutic Pool is designed for full body immersion, unless full body immersion is medically necessary and prescribed, Procedure Codes 97036 must not be reimbursed.

d. Prior written authorization must be obtained when billing for more than eight modalities, procedures or combination in one physical and occupational therapy session.

e. Therapeutic exercises and procedures codes 97150, 97110, 97530 are to be utilized by physical therapists when billing for therapeutic exercise and procedures such as, but not limited to, joint mobilization, gait training, muscle re-education, activities of daily living, patient education, etc.

#### E. Transcutaneous Electrical Nerve Stimulation (TENS)

1. TENS may be provided by the therapist when ordered by the physician, itemized in the plan of care and authorized by the carrier.

2. Reimbursement for TENS testing and training is limited to four sessions per injury.

3. Billing for TENS Equipment. When the physician recommends TENS for long-term therapy, authorization must be obtained from the carrier for rental or purchase of equipment prior to providing the equipment to the patient. For reimbursement and billing instructions, please refer to the Durable Medical Equipment Manual.

F. Medical Supplies. Medical supplies used in the course of physical and occupational therapy including dressings, splinting and orthotic materials, educational materials, lumbar and cervical rolls, etc., may be billed and reimbursed using Procedure Code 99070.

G. Fabrications of Orthotics

1. Evaluation of orthotics shall be billed according to §5127.C.

2. Fabrication and fitting of orthotics shall be billed under 97530 or 97760 as a PT/OT procedure.

3. Supplies shall be billed according to §5127.F.

H. Test and Measurements

1. Reimbursement for extremity testing, muscle testing and range of motion measurements shall be billed according to §5127.C.

2. Procedure codes 97755 shall be used when testing is performed by means of mechanical equipment. These procedure codes shall include print out of test results with report.

a. Prior authorization is required to bill 97755 if testing exceeds 30 minutes for single joint, single plane; or, 45 minutes for single joint multiple plane; or, 45 minutes for multiple joint, multiple plane for noninvolved side.

b. Prior authorization is required to bill 97755 if re-testing exceeds 15 minutes for single joint, single plane; or 30 minutes for single joint multiple plane; or, 30 minutes for multiple joint, multiple plane for noninvolved side.

I. Programs in Industrial Rehabilitation; Work Hardening and Work Conditioning

1. Operational Definitions

a. *Work Conditioning*. Work conditioning is a work-related, intensive, goal-oriented treatment program specifically designed to restore an individual's systemic, neuro-musculo-skeletal (strength, endurance, movement, flexibility and motor control) and cardiopulmonary functions. The objective of the work conditioning program is to restore the claimant's physical capacity and function so the claimant can return to work.

b. *Work Conditioning Assessment*. Work conditioning assessment is defined as evaluation(s), test(s), and procedure(s) required to identify and quantify the claimant's individual work-related, systemic, neuro-musculo-skeletal restoration needs. The results of this assessment shall be used to identify eligibility, design a plan of care, monitor progress and plan for discharge and return to work.

c. *Work Conditioner Provider*. A licensed physical therapist, a licensed occupational therapist.

d. *Work Hardening*. Work hardening is a highly structured, goal-oriented, individualized treatment program designed to return the person to work. Work hardening programs, which are interdisciplinary in nature, use real or simulated work activities designed to restore physical, behavioral, and vocational functions. Work hardening addresses the issues of productivity, safety, physical tolerances, and worker behaviors.

e. *Direct Supervision*. Direct supervision means supervision of personnel by a licensed provider who is physically available on site.

f. *Work Hardening Assessment*. Work hardening assessment is defined as interdisciplinary evaluation(s), test(s), and procedure(s) required to identify and quantify the claimant's individual restoration needs related to physical, functional, behavioral, and vocational status. The initial interdisciplinary assessment is used to identify claimant's eligibility, design a plan of care, monitor process, plan for discharge and return to work.

g. *Work Hardening Providers*. Work hardening providers include the following professionals:

- i. physical therapist;
- ii. occupational therapist;
- iii. psychologist;
- iv. vocational specialist.

2. Program Comparison

<b>Work Conditioning Program</b>	<b>Work Hardening Program</b>
Addresses physical and functional needs which may be provided by one discipline (single discipline model).	Addresses physical, functional, behavioral vocational needs within an interdisciplinary model.
Requires work conditioning assessment.	Requires work hardening assessment.
Utilizes physical conditioning and functional activities related to work.	Utilizes real or simulated work activities.
Provided in multi-hour sessions up to: 2-4 hours/day, 5 days/week, up to 6 weeks (need additional approval after this length of stay)	Provided in multi-hour sessions up to: 4-8 hours/day, 5 days/week, up to 8 weeks

3. Work Conditioning Guidelines

a. Claimant Eligibility

i. To be eligible for work conditioning, a claimant must:

- (a). have a job goal;
- (b). have stated or demonstrated willingness to participate;
- (c). have identified systemic neuro-musculo-skeletal physical and functional deficits that interfere with work;

## LABOR AND EMPLOYMENT

(d). be at a point of resolution of the initial or principal injury that participation in the work conditioning program would not be prohibited.

ii. Work conditioning generally follows acute medical care or may begin when the claimant meets the eligibility criteria.

### b. Provider Responsibility

i. The carrier/SIE should be notified prior to initiation of the program.

ii. The need for a program shall be established by a work conditioning provider based on the results of a work conditioning assessment.

iii. The program shall be provided by or under the direct supervision of a work conditioning provider.

iv. The work conditioning provider shall document all evaluations, services provided, claimant progress, and discharge plans. Information shall be available to the claimant, C/SIE, other providers, and any referral source.

v. The work conditioning provider shall develop and utilize an outcome assessment system designed to evaluate, at a minimum, patient care results, program effectiveness, and efficiency.

vi. The work conditioning providers should be appropriately familiar with job expectations, work environments, and skills required of the claimant through means such as site visitation, videotapes, and functional job descriptions.

### c. Program Content:

i. development of program goals in relation to job skills and job requirements;

ii. techniques to improve strength, endurance, movement, flexibility, motor control and cardiopulmonary capacity related to the performance of work tasks;

iii. practice, modification, and instruction in work related activities;

iv. education related to safe job performance and injury prevention;

v. promotion of claimant responsibility and self management;

vi. work conditioning programs are provided in multi-hour sessions available up to five days a week for a duration of up to eight weeks.

### d. Program Termination

i. The claimant shall be discharged from the work conditioning program when the goals for the claimant have been met.

ii. Work conditioning shall be discontinued when any of the following occur.

(a). The claimant has or develops behavioral or vocational problems which are not being addressed and which interfere with return to work.

(b). There are medical contraindications.

(c). The claimant fails to comply with the requirements of participation.

(d). The claimant's progress has reached a plateau prior to meeting goals.

(e). Services are discontinued by the referral source.

iii. When the claimant is discharged or discontinued for the work conditioning program, the work conditioning provider shall notify the C/SIE, and/or any referral source, and include the following information:

(a). reasons for program termination;

(b). clinical and functional status;

(c). recommendations regarding return to work;

(d). recommendations for follow-up services.

## 4. Work Hardening Guidelines

### a. Client Eligibility

i. To be eligible for work hardening a claimant must:

(a). have a job goal for return to work at the time of discharge;

(b). have stated or demonstrated willingness to participate;

(c). have identified physical (systemic neuromuscular-skeletal), functional, behavioral and vocational deficits that interfere with work;

(d). be at the point of resolution of the initial or principal injury that participation in the work hardening program would not be prohibited.

ii. Work hardening may begin only after the completion of the work hardening assessment.

### b. Provider Responsibility

i. The C/SIE should be notified prior to initiation of the program.

ii. The need for a program shall be based on the results from a work hardening assessment performed by all of the work hardening providers.

iii. The program components shall be provided by or under the direct supervision of the appropriate work hardening providers.

iv. The treating work hardening providers shall meet on a regular basis to discuss, coordinate and document program progress and outcome achievement.

v. The work hardening providers shall document all evaluations, services provided, claimant progress, and discharge plans. Information shall be available to the



claimant, C/SIE, other professional providers, and any referral source.

vi. The work hardening providers shall develop and utilize an outcome assessment system designed to assess, at a minimum, patient care results, program effectiveness, and efficiency.

vii. The work hardening providers should be familiar with job expectations, work environments, and skills required of the claimant through means as site visitation, videotape, functional job descriptions, interview of claimant, or interview of employer.

viii. There should be an area that is designed, arranged and equipped for the specific purpose of providing work hardening programs.

c. Program Content:

i. development of program goals in relationship to specific job requirement or specific functional goals;

ii. techniques to develop strength, endurance, movement, flexibility, motor control and cardiopulmonary capacity related to the performance of work tasks;

iii. practice, modification, and instruction in simulated or real work activities;

iv. education related to safe job performance and injury prevention;

v. provision of behavioral and vocational services as determined by the respective work hardening provider;

vi. promotion of claimant responsibility and self-management;

vii. provision in multi-hour sessions with a minimum of four hours and up to eight hours, five days a week, for duration up to eight weeks;

viii. assist the claimant to obtain as appropriate:

(a). alcohol and other drug dependency counseling;

(b). engineering and ergonomic services;

(c). medical services;

(d). nutritional and weight control services;

(e). orthotic and prosthetic services;

(f). smoking cessation counseling.

d. Program Termination

i. The claimant shall be discharged from the work hardening program when the goals for the claimant have been met.

ii. Work hardening shall be discontinued when any of the following occur.

(a). The claimant has or develops problems which cannot be addressed within the program.

(b). There are medical contraindications.

(c). The claimant demonstrates a lack of willingness to participate.

(d). The claimant fails to comply with the requirements of participation.

(e). The claimant's progress has reached a plateau prior to meeting goals.

(f). Services are discontinued by the referring source.

iii. When the claimant is discharged or discontinued from the work hardening program, the work hardening provider(s) shall notify the C/SIE and/or any referral source, and include the following information:

(a). reasons for program termination;

(b). clinical and functional status;

(c). recommendations regarding return to work;

(d). recommendations for follow-up services.

e. Work Hardening/Work Conditioning Checklist

**Work Hardening/Work Conditioning Checklist**

This checklist is intended only to be used as an outline. Please refer to billing instructions in reference to Work Hardening/Work Conditioning Guidelines for details.

**Checklist for Bill**

**Work Hardening**

- \_\_\_ 1. No additional modality charge should be added to a work hardening charge
- \_\_\_ 2. Services rendered by a licensed Physical Therapist or Occupational Therapist
- \_\_\_ 3. Maximum length of stay for work hardening is eight weeks
- \_\_\_ 4. Program should be daily after first week of evaluation
- \_\_\_ 5. Claimant should not have frequent unexcused absences
- \_\_\_ 6. Preauthorization obtained

**Work Conditioning**

- \_\_\_ 1. No additional modality charge should be added to a work conditioning charge
- \_\_\_ 2. Services rendered by a licensed Physical Therapist or Occupational Therapist
- \_\_\_ 3. Maximum length of stay for work conditioning is six weeks
- \_\_\_ 4. Program should be three to five weeks
- \_\_\_ 5. Claimant should not have frequent unexcused absences
- \_\_\_ 6. Preauthorization obtained

**Checklist for Medical Records**

**Work Hardening**

- \_\_\_ 1. Thorough initial evaluation to include history, musculo-skeletal assessment, functional testing and job description or job evaluation
- \_\_\_ 2. Treatment plan
- \_\_\_ 3. Documentation of claimant staffings
- \_\_\_ 4. Claimant's progress documented in progress notes
- \_\_\_ 5. Discharge evaluation and discharge report
- \_\_\_ 6. Documentation of claimant education
- \_\_\_ 7. Documentation of work simulation tasks
- \_\_\_ 8. Documentation of therapeutic exercise task
- \_\_\_ 9. Documentation of aerobic conditioning tasks
- \_\_\_ 10. Documentation of four to eight hour daily program

## LABOR AND EMPLOYMENT

### Work Conditioning

- \_\_\_ 1. Thorough initial evaluation to include history, musculo-skeletal assessment, functional testing and job description or job evaluation
- \_\_\_ 2. Treatment plan
- \_\_\_ 3. Claimant's progress documented in progress notes
- \_\_\_ 4. Discharge evaluations and discharge reports
- \_\_\_ 5. Documentation of claimant education
- \_\_\_ 6. Documentation of work simulation tasks
- \_\_\_ 7. Documentation of therapeutic exercise tasks
- \_\_\_ 8. Documentation of aerobic conditioning tasks
- \_\_\_ 9. Documentation of two to four hour daily program

AUTHORITY NOTE: Promulgated in accordance with R.S. 23:1034.2.

HISTORICAL NOTE: Promulgated by the Department of Labor, Office of Workers' Compensation, LR 19:54 (January 1993), repromulgated LR 19:212 (February 1993), amended LR 20:1299 (November 1994), amended by the Workforce Commission, Office of Workers' Compensation, LR 40:376 (February 2014).

### §5129. Allergy and Clinical Immunology

A. Procedure Codes 95004-95199 must be billed for allergy testing and allergy immunotherapy.

B. When billing for allergy tests, enter the appropriate CPT procedure code in Item 24-D of the HCFA 1500 Form.

1. Enter the total number of tests performed in Item 24-G.
2. Enter the total amount charged for the procedure code in Item 24-F.
3. Allergy skin testing is reimbursed on a per test basis.

C. When billing for test where antigens are specified in the descriptor, the appropriate procedure code must be entered in Item 24.

1. Enter the total number of antigens in Item 24-G.
2. Enter the provider's usual total charge in Item 24-F.
3. Reimbursement is based on a per antigen basis.

AUTHORITY NOTE: Promulgated in accordance with R.S. 23:1034.2.

HISTORICAL NOTE: Promulgated by the Department of Labor, Office of Workers' Compensation, LR 19:54 (January 1993), repromulgated LR 19:212 (February 1993), amended LR 20:1299 (November 1994).

### §5131. Biofeedback

A. Biofeedback training may be reimbursed when it is medically necessary. A written plan of care which includes objectives, the estimated length of treatment and stated goals must be submitted to the carrier/self-insured employer for approval prior to the services being provided.

B. The reimbursement of biofeedback is limited to providers currently licensed or certified to provide biofeedback services. Providers include:

1. physicians currently licensed in Louisiana who are certified by or meet certification requirements of the Biofeedback Certification Institute of America;

2. physical therapists and occupational therapists, licensed through the license laws of Louisiana, and biofeedback therapists, certified by the Biofeedback Certification Institute of America, who are employed by physicians. Billings for these biofeedback services provided by these therapists must be submitted by the employer (physician). The appropriate license or certification number must be placed in Item 24-K on the HCFA 1500 Billing Form to receive reimbursement for these procedures.

C. Biofeedback training procedures must be billed under the appropriate procedure codes listed in the CPT (90900-90915) or PT260, PT265 or OT260, OT265.

D. Reimbursement for biofeedback training is limited to 12 visits. One or more procedure may be provided during a visit if medically necessary and included in the approved plan of care.

AUTHORITY NOTE: Promulgated in accordance with R.S. 23:1034.2.

HISTORICAL NOTE: Promulgated by the Department of Labor, Office of Workers' Compensation, LR 19:54 (January 1993), repromulgated LR 19:212 (February 1993), amended LR 20:1299 (November 1994).

### §5133. Injections

A. Subcutaneous, Intramuscular and Intravenous

1. Procedure Codes 90700-90749 are reimbursed by report only. The report must include the name of the medication strength and volume injected.

2. When multiple drugs are administered from the same syringe, Modifier-51 must be added to the procedure codes for the second and subsequent drugs.

3. Reimbursement for multiple drugs administered from the same syringe must be at the provider's usual charge or the maximum reimbursement allowable, whichever is less for the first drug, and the provider's charge or 50 percent of the maximum reimbursement allowable, whichever is less for each additional drug.

4. Reimbursement for injections includes the cost of the drug, the charge for the administration of the drug and the cost of the supplies used to administer the drug.

5. Reimbursement for anesthetic agents, such as Xylocaine and Carbocaine, when used for infiltration, is included in the reimbursement for the basic procedure performed and must not be separately reimbursed.

B. Intra-Articular or Intrabursal Injections

1. CPT Procedure Codes 20550-20615 must be billed for intra-articular or intrabursal injections.

2. Reimbursement for these injection codes includes the supplies usually required to perform the procedure, but not the medications.

3. An invoice documenting the cost of the injectable medications must be submitted with the claim form since reimbursement is limited to the provider's charge or up to 20 percent above the actual cost to the provider, whichever is less.

**AUTHORITY NOTE:** Promulgated in accordance with R.S. 23:1034.2.

**HISTORICAL NOTE:** Promulgated by the Department of Labor, Office of Workers' Compensation, LR 19:54 (January 1993), repromulgated LR 19:212 (February 1993), amended LR 20:1299 (November 1994).

**§5135. Evaluation and Management**

A. Examination, evaluations, treatments, conferences with or concerning patients, and similar medical services necessitate wide variations in the skill, effort, time, responsibility and medical knowledge required for the diagnosis and treatment of work-related illnesses and on the job injuries. The various types of physician visits have been categorized into different levels of service in the CPT.

B. Reimbursement may be made for only one visit per physician per patient per day at the highest level of care provided.

C. When billing for visit and consultations, providers must use the appropriate CPT procedure code that best describes the service rendered.

D. Consultation Services (Procedure Codes 99241-99275).

1. A consultation includes services rendered by a physician whose opinion or advice is requested by another physician or other appropriate source for the further evaluation and/or management of the patient.

a. A consultant may initiate diagnostic or therapeutic services at the request of the attending physician.

b. When the documentation supports a consultative service, reimbursement must be at the appropriate consultative level.

c. A copy of the consultation report must be submitted with the bill in order for reimbursement to be made.

d. The reimbursement for a consultation includes payment for the report. Separate reimbursement must not be made for the report.

e. When a physician performs consultative services and subsequently becomes the treating physician for either total or partial care, reimbursement for the consultative services should not be denied by the carrier. The subsequent services must be billed and reimbursed under the appropriate visit codes, not consultation codes.

E. Hospital Discharge Day Management (Procedure Code 99238). Reimbursement must not be made for this service in addition to another hospital visit billed by the same physician on the same day for the same patient.

**AUTHORITY NOTE:** Promulgated in accordance with R.S. 23:1034.2.

**HISTORICAL NOTE:** Promulgated by the Department of Labor, Office of Workers' Compensation, LR 19:54 (January 1993), repromulgated LR 19:212 (February 1993), amended LR 20:1299 (November 1994).

**§5137. Neurologic and Neuromuscular Services**

A. General

1. Neurologic services are typically consultation services and any of the levels of consultation (Procedure Codes 99241-99263) may be appropriate. However, when one is the attending physician for or partial care, the appropriate evaluation and management level of service must be billed.

2. Diagnostic studies (nerve conduction tests, electromyograms, electroencephalograms, etc.) are reimbursable in addition to the office visit or consultative service.

3. Diagnostic study includes both a technical component (equipment, technical personnel, supplies, etc.) and a professional component (interpreting test results, written reports, etc.).

4. Billing of the five-digit CPT neurological and neuromuscular procedure codes indicate that the complete service (professional and technical components) is being billed. Reimbursement is the lesser of the provider's charge or the MRA for the procedure.

5. When the professional and technical components are performed by two different health care providers, the total reimbursement for both components must not exceed the listed MRA.

a. The physician bills for the test interpretation and written report by adding Modifier-26 to the five-digit procedure code. The reimbursement is the lesser of the provider's charge or the MRA listed for the five digit procedure code plus Modifier-26.

b. The health care provider who performs the technical component bills for the technical component by adding Modifier-90 to the five digit procedure code. The reimbursement for the technical component is the lesser if the provider's charge or the difference between the MRA for the total procedure and the MRA for the five-digit procedure code plus Modifier-90.

c. When a procedure coded does not list a separate amount for the professional component, reimbursement for the professional component must not exceed 85 percent of the total MRA. The reimbursement for the technical component must not exceed 15 percent of the total MRA.

6. When the diagnostic services are provided at a hospital or ambulatory surgical center, the hospital or ambulatory surgical center bills for the technical services and the physician bills for the professional component only, using Modifier-26.

B. Specific

1. Extremity Testing, Muscle Testing and Range of Motion (ROM) Measurements (Procedure Codes 95831-95852 and 97720-97752)

a. Visits/Consultations

i. When a visit/consultation is made for the purpose of an assessment and evaluation of the patient, the visit/consultation may be reimbursed at the appropriate level of service. Extremity, muscle and ROM tests and measurements performed during the visit must not be

## LABOR AND EMPLOYMENT

reimbursed as separate entities. As these tests are an integral part of the visit/consultation, reimbursement for these tests and measurements is included in the reimbursement for the visit/consultation.

ii. When an office visit/consultation is made solely for the purpose of performing tests and measurements, these testing procedures may be reimbursed as separate entities. Reimbursement must not be made for a visit in addition to the test.

b. When performed as separate procedures, muscle testing and range of motion measurements require objective measurements of the muscle and joint functions being tested. For reimbursement to be made, reports showing these measurements must accompany the billing of these codes.

c. Procedure Code 97752 must be used when testing is performed by means of mechanical equipment.

### d. Reimbursement

i. Reimbursement for extremity testing, muscle testing and range of motion measurements may be made only one in a 30-day period for the same body area.

ii. When two or more procedures from 95831 through 95852 are performed for the same patient by the same physician on the same date of service, the total reimbursement allowance may not exceed the reimbursement for Procedure Code 95834 (total evaluation of body, including hands).

AUTHORITY NOTE: Promulgated in accordance with R.S. 23:1034.2.

HISTORICAL NOTE: Promulgated by the Department of Labor, Office of Workers' Compensation, LR 19:54 (January 1993), repromulgated LR 19:212 (February 1993), amended LR 20:1299 (November 1994).

## §5139. Psychiatry

### A. General

1. Psychiatric evaluations may be provided as independent medical examinations (IMEs) when requested by the carrier/self-insured employer.

2. Psychiatric evaluations may be provided as consultations when requested by a physician and when authorized by the carrier/self-insured employer.

3. Upon authorization by the carrier/self-insured employer psychiatric treatment may be provided when documentation submitted by the physician to the carrier/self-insured employer substantiates the medical necessity of the treatment and includes the estimated length of treatment.

4. Reimbursement for a routine medical visit rendered by the same physician on the same day as psychiatric therapy is included in the reimbursement for the more comprehensive service.

5. Hypnosis may be reimbursed when it is an integral part of a plan for the treatment of post-traumatic stress disorders arising from on-the-job injuries.

### B. Reimbursement

1. Psychiatric Diagnostic Interview (Procedure Code 90801). Reimbursement for this service includes history and mental status determination, development of a treatment plan when treatment is necessary, and the preparation of a written report.

2. Psychological Testing (Procedure Codes 90830, 95880, 95881, 95882)

a. Reimbursement for these procedures includes the administration of the test, scoring interpretation of results and preparation of a written report.

b. In order for appropriate reimbursement to be made, each test must be specifically identified on the HCFA 1500 Form by the appropriate procedure code.

c. The total charge for the test must be entered in Item 24-F on the HCFA 1500 Form.

d. A single unit of service must be entered in Item 24-G for each test.

3. Medical Psychotherapy (Procedure Codes 90841-90853)

a. Individual psychotherapy must be billed under the procedure code most closely approximating the length of the session.

b. Group psychotherapy generally requires 75 to 90 minutes per session. When a psychiatric treatment program includes group sessions routinely scheduled for more or less time than this, appropriate modifiers should be used.

4. Psychiatric services may be reimbursed when billed by Louisiana licensed physicians who are certified by, or who have satisfactorily completed the specialized training requirements of, the American Board of Psychiatry and Neurology or the American Osteopathic Board of Neurology and Psychiatry. These physicians must either perform the service directly or provide direct supervision of qualified mental health professionals performing the service as required under the applicable Louisiana statutes.

5. Psychiatric diagnostic, evaluative and therapeutic procedures must be billed under appropriate CPT procedure codes.

AUTHORITY NOTE: Promulgated in accordance with R.S. 23:1034.2.

HISTORICAL NOTE: Promulgated by the Department of Labor, Office of Workers' Compensation, LR 19:54 (January 1993), repromulgated LR 19:212 (February 1993), amended LR 20:1299 (November 1994).

## §5141. Soft Tissue Injury Care

### A. Initial Visits

1. Initial (new patient) treatment for soft tissue injuries must be billed under the appropriate medical (office) visit code.

2. When a cast or strapping is applied during initial visit, supplies and materials used such as stockinette, plaster, fiberglass, ace bandages, etc., may be itemized and billed separately using Procedure Code 99070.

3. Replacement casting and strapping codes (29000-29799) must not be used for initial care.

B. Follow-Up Visits

1. Replacement casts or strapping, provided during follow-up visits, must be billed under the appropriate replacement Procedure Codes (29000-29799).

2. The reimbursement for replacement casts or strapping includes reimbursement for the service, supplies and materials usually required and the removal of casts, splints or strapping.

3. Special supplies, such as fiberglass casting materials, may be billed under Procedure Code 99070 and reimbursed separately.

4. Follow-up visit charges may be reimbursed in addition to replacement casting and strapping procedures only when significant, identifiable, further medical services are provided. The HCFA 1500 Form should indicate an additional diagnosis, when appropriate, and office notes should substantiate the medical necessity of the visit.

5. When replacement and strapping procedures are not performed during follow-up visits, the services should be billed under the appropriate established patient visit code in the evaluation and management section.

6. When an initial casting and strapping is applied for the first time during a follow-up visit, reimbursement may be made for the supplies and materials itemized under Procedure Code 99070 in addition to the appropriate established patient follow-up visit level.

AUTHORITY NOTE: Promulgated in accordance with R.S. 23:1034.2.

HISTORICAL NOTE: Promulgated by the Department of Labor, Office of Workers' Compensation, LR 19:54 (January 1993), repromulgated LR 19:212 (February 1993), amended LR 20:1299 (November 1994).

**§5143. Thermography**

A. General Information

1. When medically necessary, thermographic testing may be used as an assistive device in the diagnosis of many different conditions.

2. When a request for authorization for thermography is received, carriers must ensure that a specially trained, qualified physician is to perform the test and that written documentation of medical necessity is obtained, when necessary, to substantiate the service.

3. As with all diagnostic tests, thermography should be ordered with discretion by the attending physician and authorized with discretion by the carrier.

B. Authorization

1. Prior to performing a thermographic test, thermography test, a physician must request authorization from the carrier.

2. Upon request, a physician must submit to the carrier written documentation of medical necessity for the thermographic testing.

3. Upon request by the carrier, a physician must submit documentation of certification or credentials supporting his/her qualifications for the provision of thermography.

4. Thermographic tests must not be authorized unless the date of service is at least 45 days after the date of accident unless it is medically necessary to provide the service at an earlier date and documentation of medical necessity is submitted to the carrier.

C. Body Areas

1. Major Body Areas (The following areas include all views):

- a. head;
- b. cervical spine and upper extremities;
- c. lumbosacral spine and lower extremities.

2. Limited Body Areas (The following areas include all views):

- a. thoracic spine;
- b. any portion of a major area.

D. Billing

1. When performed to the entire head, Procedure Code 93760 must be used.

2. When performed to a portion of the head, e.g., temporomandibular joint, Modifier-52 must be added to 93760 to indicate a limited area. The exact site must be specified in Item 24-D on the HCFA 1500 Form.

3. When performed to a body area other than the head, Procedure Code 93762 must be used.

4. When performed to either the thoracic area or a portion of a major area, e.g., wrist or foot, Modifier-52 must be added to 93762 to indicate a limited area. The exact site must be specified in Item 24-D on the HCFA 1500 Form.

E. Reimbursement

1. Reimbursement is limited to one body area either major or limited, unless an additional area(s) is medically necessary and documentation of medical necessity is submitted to the carrier.

2. Reimbursement for thermography to a major body area must be at the provider's usual charge or the MRA, whichever is less.

3. Reimbursement for thermography to a limited body area must be at the provider's usual charge or 50 percent of the MRA, whichever is less.

AUTHORITY NOTE: Promulgated in accordance with R.S. 23:1034.2.

HISTORICAL NOTE: Promulgated by the Department of Labor, Office of Workers' Compensation, LR 19:54 (January 1993), repromulgated LR 19:212 (February 1993), amended LR 20:1299 (November 1994).

**§5145. Carrier Responsibilities for Reimbursement Determinations**

A. Medical Consultant. Carriers must utilize the expertise of physicians or other health care professionals in making determinations pertaining to acceptable, safe medical care and treatment and appropriate reimbursement for services rendered. The consultants should have expertise in the areas for which medical or other treatment determinations are made.

B. Carriers must not change, alter, delete or obscure procedure codes.

1. When a carrier questions a procedure code reported by a provider, the carrier must contact the provider for clarification prior to reimbursing a claim. This may result in the carrier requesting additional documentation or a copy of the office or progress note to substantiate the service in question from the provider.

2. If after contacting the provider a carrier determines that available provider documentation does not support the level of service billed the carrier may reimburse the provider at the appropriate level but must ensure that an explanation of medical benefits specifically denotes the action taken and explains the reimbursement made for the service in question.

AUTHORITY NOTE: Promulgated in accordance with R.S. 23:1034.2.

HISTORICAL NOTE: Promulgated by the Department of Labor, Office of Workers' Compensation, LR 19:54 (January 1993), repromulgated LR 19:212 (February 1993), amended LR 20:1299 (November 1994).

**§5147. Explanation of Medical Benefits (EOMB)**

A. Carriers must provide an explanation of medical benefits (EOMB) to health care providers whenever the carrier's reimbursement differs from the amount billed by the provider. The EOMB must be provided with the reimbursement check.

1. A carrier must use the listed EOMB codes and descriptors to explain why a provider's charge has been reduced or disallowed.

2. A carrier may develop additional EOMB codes, if necessary, to explain the adjustment of a claim, but must furnish to the provider a written explanation of each EOMB code used.

3. The EOMB must contain appropriate identifying information so the provider can relate a specific reimbursement to the applicable claimant, the procedure billed and the date of service.

B. Acceptable EOMBs may include:

1. copies of the bill on which reimbursements and EOMB codes are listed;

2. manually produced or computerized forms which contain the EOMB codes, written explanations and the appropriate identifying information.

C. The following EOMB codes must be used by the carrier to explain to the provider why a procedure or service is not reimbursed as billed.

001	These services are not reimbursable under the Workers' Compensation Program.
002	Charges exceed maximum allowance.
003	Charge is included in the basic surgical allowance.
004	Surgical assistant is not routinely allowed for this procedure. Documentation of medical necessity required.
005	This procedure is included in the basic allowance of another procedure.
006	This procedure is not appropriate to the diagnosis.
007	This procedure is not within the scope of the license of the billing provider.
008	Equipment of services are not prescribed by a physician.
009	Exceeds reimbursement limitations.
010	This service is not reimbursable unless billed by a physician.
011	Incorrect billing form.
012	Incorrect or incomplete license number of billing provider.
013	Medical report required for payment.
014	Documentation does not justify level of service billed.
015	Place of service is inconsistent with procedure billed.
016	Invalid procedure code.

AUTHORITY NOTE: Promulgated in accordance with R.S. 23:1034.2.

HISTORICAL NOTE: Promulgated by the Department of Labor, Office of Workers' Compensation, LR 19:54 (January 1993), repromulgated LR 19:212 (February 1993), amended LR 20:1299 (November 1994).

**§5149. Reconsideration of Disputed Reimbursements**

A. When, after examination of the EOMB, a health care provider is dissatisfied with a carrier's payment of a bill for medical services, a reconsideration may be requested by the provider.

1. A provider must make a written request for reconsideration within 60 days from receipt of the EOMB, accompanied by a copy of the bill in question, the carrier's EOMB and any supporting documentation to substantiate the medical necessity of the service and the diagnosis provided.

2. The carrier must process a reconsideration within 60 days of receipt.

a. The carrier must review and re-evaluate the original bill and accompanying documentation using its own medical consultant if necessary.

b. The carrier must notify the provider within 60 days of the results of the reconsideration, explain the reason(s) for their decision and cite the specific policy upon which their final adjustment was made.

B. The provider may request the Office of Workers' Compensation Administration, Medical Services Section, to resolve the dispute if the result of the carrier's reconsideration remains unsatisfactory.

C. The Office of Workers' Compensation Administration's Medical Services Section will resolve disputes between a provider and carrier which involve the interpretation of the reimbursement policies and allowable reimbursement contained in the applicable reimbursement manual.

1. A written request for the resolution of a disputed reimbursement claim must be submitted to the Office of Workers' Compensation Administration within 60 days of

the carrier's reconsideration or 90 days from the provider's requested date when no response is received.

2. Valid request for reconsideration must include copies of the following:

- a. copies of the original and resubmitted bills;
- b. EOMBs including the specific reimbursement;
- c. supporting documentation and correspondence;
- d. specific information regarding contact with the carrier.

3. The dispute will be reviewed by the Office of Workers' Compensation Administration, Medical Services Section, and both parties, the provider and the carrier, will be notified of the decision within 60 days after receipt of a valid request.

4. Request for resolving disputes may be sent to:

Office of Workers' Compensation  
 Medical Services Section  
 Attn: Medical Services Manager  
 Box 94040  
 Baton Rouge, LA 70804-9040

AUTHORITY NOTE: Promulgated in accordance with R.S. 23:1034.2.

HISTORICAL NOTE: Promulgated by the Department of Labor, Office of Workers' Compensation, LR 19:54 (January 1993), repromulgated LR 19:212 (February 1993), amended LR 20:1299 (November 1994).

**§5151. Out-of-State, On-the-Job Injuries or Work-Related Illness Treated in Louisiana**

A. A patient may receive medical services in Louisiana for injuries incurred in an out-of-state accident.

1. If the patient is receiving treatment under the Workers' Compensation Law of another state, this manual may not apply.

2. If the patient is receiving care and treatment in Louisiana pursuant to the Louisiana Act, the reimbursement is subject to the requirements and amount of this manual regardless of the site of injury.

B. Providers may contact carriers to determine whether or not claimant benefits are provided pursuant to Louisiana law or the law of another state or under the jurisdiction of other Workers' Compensation Laws.

AUTHORITY NOTE: Promulgated in accordance with R.S. 23:1203 and 1034.2.

HISTORICAL NOTE: Promulgated by the Department of Labor, Office of Workers' Compensation, LR 19:54 (January 1993), repromulgated LR 19:212 (February 1993), amended LR 20:1299 (November 1994).

**§5153. In State Medical Treatment**

A.1. Each employer shall furnish all necessary drugs, supplies, hospital care and services, medical and surgical treatment, and any nonmedical treatment recognized by the laws of this state as legal. All such care, services, and treatment shall be performed at facilities within the state when available.

2. When billing for out-of-state services, supporting documentation is necessary to show that the service being provided cannot be performed within the state, or it is closer to patient's domicile to have services performed out of state.

B. The reimbursement allowances of this manual are not applicable to medical services rendered outside the state of Louisiana even though the services are provided under the Louisiana Workers' Compensation Statutes.

C. Health Care providers are required to report treatment to the carrier/self insured employer on the:

- 1. HCFA 1500 Form;
- 2. UB-92; or
- 3. ADA - Dental Claim Form.

D. Reimbursement for out of state services shall be based on one of the following:

- 1. the workers' compensation reimbursement schedule for the state in which services are rendered; or
- 2. the usual and customary fee for the geographic area in which the services are rendered.

AUTHORITY NOTE: Promulgated in accordance with R.S. 23:1203 and 1034.2.

HISTORICAL NOTE: Promulgated by the Department of Labor, Office of Workers' Compensation, LR 19:54 (January 1993), repromulgated LR 19:212 (February 1993), amended LR 20:1299 (November 1994).

Editor's Note: In addition, the following Sections of this Chapter are applicable and shall be used for the other Chapters in this Part governing reimbursement. These specific Chapters are: Chapter 31, Vision Care Services; Chapter 33, Hearing Aid Equipment and Services; Chapter 35, Nursing Attendant Care and Home Health Services; Chapter 39, Medical Transportation; Chapter 41, Durable Medical Equipment and Supplies; Chapter 43, Prosthetic and Orthopedic Equipment; Chapter 45, Respiratory Services; Chapter 47, Miscellaneous Claimant Expenses; and Chapter 49, Vocational Rehabilitation Consultant; and Chapter 51, Medical Reimbursement Schedule.

**§5155. Maintenance of Schedule**

A. Maintenance of the schedules requires that a database of applicable charges be accumulated by the carrier/self-insured employer. This database will be utilized to profile the charges by each appropriate code.

B. Information Required. In order to update the schedule, each carrier/self-insured employer shall submit the following information for claims incurred in the preceding period. This information shall be submitted to the OWCA upon request. Failure to do so may subject the payor to penalties. The information required for calculation of the reimbursement schedule will include:

Field Name	Length	Type
CPT/HCPCS	5	Alpha/Numeric
Modifier	2	Alpha/Numeric
Unit/Days	3	Numeric
Amount Charged	10	Numeric
Amount Paid	10	Numeric

LABOR AND EMPLOYMENT

C. Communication Format. The above information shall be submitted in the following format.

1. Magnetic tape:

- a. tape 9-track, 8.5-inch to 10.5-inch reels with silver mylar reflector (standard reels) with write-ring removed;
- b. recording density—1600 or 6250 bytes per inch;
- c. recording code—Extended Binary Coded Decimal Interchange Code (EBCDIC);
- d. header record must identify submitter and position of each field in the record;
- e. tape must have a leading tape mark and an end of file mark;
- f. the external label must identify the submitter, the date submitted, the tape number with identification of the total number of tapes submitted and a descriptive narrative of the information contained within the records.

D. Diskettes

1. A 5.25 inch diskette (floppy disk) that is IBM PC-DOS compatible with the following attributes:

- a. double sided;
- b. double density;
- c. soft sectored;
- d. 9 sectors per track; and
- e. 40 tracks per diskette.

2. A 3.5 inch, 720K diskette, that is IBM PC-DOS compatible with the following attributes:

- a. double sided;
- b. double density.

3. The external label must identify the submitter, the date submitted, the diskette number with identification of the number of total number of diskettes submitted and the descriptive narrative of the information contained within the records.

AUTHORITY NOTE: Promulgated in accordance with R.S. 23:1034.2.

HISTORICAL NOTE: Promulgated by the Department of Labor, Office of Workers' Compensation, LR 19:54 (January 1993), repromulgated LR 19:212 (February 1993), amended LR 20:1299 (November 1994).

**§5157. Maximum Reimbursement Allowances**

A. Table 1

Maximum Fee Allowance Schedule Office of Workers' Compensation				
CPT Code	Mod	Description	Global Days	Maximum Allowance
00124		Otoscopy		4 + TM
00126		Tympanotomy		4 + TM
00140		Procedures on eye nos		5 + TM
00142		Lens surgery		6 + TM
00144		Corneal transplant		6 + TM
00145		Vitrectomy		6 + TM
00147		Iridectomy		6 + TM
00148		Ophthalmoscopy		4 + TM
00160		Nose and accessory sinuses nos		5 + TM
00162		Nose, radical surgery		7 + TM
00164		Nose, biopsy, soft tissue		4 + TM
00170		Intraoral procedures, inc bx nos		5 + TM
00172		Intraoral, repair of cleft palate		6 + TM
00174		Intraoral exc retropharyngeal tumor		6 + TM
00176		Intraoral radical surgery		7 + TM
00190		Procedures on facial bones; nos		5 + TM
00192		Facial bones; radical surgery		7 + TM
00210		Intracranial procedures; nos		11 + TM
00211		Anesthesia for intracranial procedures; craniotomy or craniectomy for evacuation of hematoma		10 + TM
00212		Subdural taps		5 + TM
00214		Burr holes		9 + TM
00215		Skull fracture		9 + TM
00216		Intracranial vascular procedures		15 + TM
00218		Intracranial proc sitting position		13 + TM
00220		Spinal fluid shunting procedures		10 + TM
00222		Electrocoag intracranial nerve		6 + TM
00300		Integ sys neck, inc subcut tissue		5 + TM
00320		Neck procedures exc integ system		6 + TM
00322		Needle biopsy of thyroid		3 + TM
00326		Anesth, larynx/trach, < 1 yr		7 + TM
00350		Major vessels of neck; nos		10 + TM
00352		Major vesels neck; simple ligation		5 + TM
00400		Ant integ system chest; nos		3 + TM
00402		Reconstructive procedures on breast		5 + TM
00404		Radical/mod radical breast		5 + TM
00406		Radical/mod breast w/node dissect		13 + TM
00410		Cardioversion		4 + TM
00450		Clavicle and scapula; nos		5 + TM
00452		Clavicle and scapula; radical surgery		6 + TM
00454		Biopsy of clavicle		3 + TM
00470		Partial rib resection; nos		6 + TM
00472		Thoracoplasty		10 + TM
00474		Rib resection; radical procedures		13 + TM
00500		Procedures on esophagus		15 + TM
00520		Closed chest procedures nos		6 + TM
00522		Needle biopsy of pleura		4 + TM
00524		Pneumocentesis		4 + TM
00528		Mediastinoscopy		8 + TM
00529		Anesth, chest partition view		11 + TM
00530		Transvenous pacemaker insertion		4 + TM
00532		Access central venous circulation		4 + TM
00534		Transvenous cardioverter/defibrill		7 + TM
00537		Anesth, cardiac electrophys		7 + TM
00539		Anesth, trach-bronch reconst		18 + TM
00540		Thoracotomy procedures; nos		13 + TM
00541		Anesth, one lung ventilation		15 + TM
00542		Decortication		15 + TM
00546		Pulmonary resect w/thoracoplasty		15 + TM
00548		Repair trauma trachea/bronchi		15 + TM
00550		Anesth, sternal debridement		10 + TM
00560		Heart, pericardium, w/o pump		15 + TM
00561				25 + TM

Maximum Fee Allowance Schedule Office of Workers' Compensation				
CPT Code	Mod	Description	Global Days	Maximum Allowance
00100		Anesthesia for procedures on salivary glands, including biopsy		5 + TM
00102		Plastic repair of cleft lip		6 + TM
00103		Blepharoplasty		5 + TM
00104		Electroconvulsive therapy		4 + TM
00120		Ext, mid, and inner ear inc bx; nos		5 + TM



Maximum Fee Allowance Schedule Office of Workers' Compensation				
CPT Code	Mod	Description	Global Days	Maximum Allowance
00562		Heart, pericardium, w/ pump		20 + TM
00563		Anesth, heart surg w/arrest		25 + TM
00566		Anesthesia for direct coronary artery bypass grafting; without pump oxygenator		25 + TM
00567		Anesthesia for direct coronary artery bypass grafting; with pump oxygenator		18 + TM
00580		Heart, heart/lung transplant		20 + TM
00600		Cervical spine and cord; nos		10 + TM
00604		Post cervical laminectomy sitting		13 + TM
00620		Thoracic spine and cord; nos		10 + TM
00622		Thoracolumbar sympathectomy		13 + TM
00625		Anes spine tranthor w/o vent		13 + TM
00626		Anes, spine transthor w/vent		15 + TM
00630		Procedures in lumbar region; nos		8 + TM
00632		Lumbar sympathectomy		7 + TM
00634		Chemoneurololysis		10 + TM
00635		Anesth, lumbar puncture		4 + TM
00640		Anesth, spine manipulat		3 + TM
00670		Extensive spine/cord procedures		13 + TM
00700		Upper anterior abdominal wall nos		3 + TM
00702		Percutaneous liver biopsy		4 + TM
00730		Upper posterior abdominal wall		5 + TM
00740		Upper gi endoscopic procedures		5 + TM
00750		Hernia repairs upper abdomen nos		4 + TM
00752		Lumbar and ventral hernias		6 + TM
00754		Omphalocele		7 + TM
00756		Transabd repair diaphragm hernia		7 + TM
00770		Major abdominal blood vessels		15 + TM
00790		Intraperitoneal proc upper abd; nos		7 + TM
00792		Partial hepatectomy		13 + TM
00794		Pancreatectomy, partial or total		8 + TM
00796		Liver transplant (recipient)		30 + TM
00797		Anesth, surgery for obesity		11 + TM
00800		Lower anterior abdominal wall; nos		3 + TM
00802		Panniculectomy		5 + TM
00810		Intestinal endoscopic procedures		5 + TM
00820		Lower posterior abdominal wall		5 + TM
00830		Hernia repairs lower abdomen; nos		4 + TM
00832		Ventral and incisional hernias		6 + TM
00834		Anesth, hernia repair< 1 yr		5 + TM
00836		Anesth hernia repair preemie		6 + TM
00840		Intraperitoneal proc lower abd; nos		6 + TM
00842		Amniocentesis		4 + TM
00844		Abdominoperineal resection		7 + TM
00846		Radical hysterectomy		8 + TM
00848		Pelvic exenteration		8 + TM
00851		Anesth, tubal ligation		6 + TM
00860		Extraperitoneal proc lower abd; nos		6 + TM
00862		Renal procedures/donor nephrectomy		7 + TM
00864		Total cystectomy		8 + TM
00865		Radical prostatectomy		7 + TM
00866		Adrenalectomy		10 + TM
00868		Renal transplant (recipient)		10 + TM
00870		Cystolithotomy		5 + TM
00872		Lithotripsy, w/ water bath		7 + TM
00873		Lithotripsy, w/o water bath		5 + TM
00880		Major lower abdominal vessels; nos		15 + TM
00882		Inferior vena cava ligation		10 + TM
00902		Anorectal procedure		4 + TM
00904		Radical perineal procedure		7 + TM
00906		Vulvectomy		4 + TM
00908		Perineal prostatectomy		6 + TM
00910		Transurethral procedures; nos		3 + TM

Maximum Fee Allowance Schedule Office of Workers' Compensation				
CPT Code	Mod	Description	Global Days	Maximum Allowance
00912		Tur bladder tumor(s)		5 + TM
00914		Transurethral resection prostate		5 + TM
00916		Post turp bleeding		5 + TM
00918		Fragment/removal ureteral calculus		5 + TM
00920		Male external genitalia; nos		3 + TM
00921		Anesth, vasectomy		3 + TM
00922		Seminal vesicles		6 + TM
00924		Undescended testis		4 + TM
00926		Radical orchiectomy, inguinal		4 + TM
00928		Radical orchiectomy, abdominal		6 + TM
00930		Orchiopexy, unilateral or bilateral		4 + TM
00932		Complete amputation of penis		4 + TM
00934		Rad amp penis w/ biling lymphad		6 + TM
00936		Rad amp penis w/ biling/iliac lymph		8 + TM
00938		Insertion of penile prosthesis		4 + TM
00940		Vaginal procedures; nos		3 + TM
00942		Colpotomy, colporrhaphy		4 + TM
00944		Vaginal hysterectomy		6 + TM
00948		Cervical cerclage		4 + TM
00950		Culdoscopy		5 + TM
00952		Hysteroscopy		4 + TM
01112		Anesth, bone aspirate/bx		5 + TM
01120		Bony pelvis		6 + TM
01130		Body cast application or revision		3 + TM
01140		Interpelviabdominal amputation		15 + TM
01150		Rad proc tumor pelvis,		8 + TM
01160		Closed procedures symphysis pubis		4 + TM
01170		Open proc symphysis pubis/sacroilia		8 + TM
01173		Anesth, fx repair, pelvis		12 + TM
01180		Obturator neurectomy; extrapelvic		3 + TM
01190		Intrapelvic		4 + TM
01200		Closed procedures hip joint		4 + TM
01202		Arthroscopic procedures hip joint		4 + TM
01210		Open procedures hip joint; nos		6 + TM
01212		Hip disarticulation		10 + TM
01214		Total hip replacement or revision		8 + TM
01215		Anesth, revise hip repair		10 + TM
01220		Closed procedures upper femur		4 + TM
01230		Open procedures upper femur; nos		6 + TM
01232		Amputation		5 + TM
01234		Radical resection		8 + TM
01250		Nerves, muscles, etc, upper leg		4 + TM
01260		Veins upper leg, including explore		3 + TM
01270		Arteries upper leg, inc bypass; nos		8 + TM
01272		Femoral artery ligation		4 + TM
01274		Femoral artery embolectomy		6 + TM
01320		Nerves, muscles, etc, knee		4 + TM
01340		Closed procedures lower femur		4 + TM
01360		Open procedures lower of femur		5 + TM
01380		Closed procedures knee joint		3 + TM
01382		Arthroscopic procedures knee joint		3 + TM
01390		Closed procedures uppr tibia/fibula		3 + TM
01392		Open procedures upper tibia/fibula		4 + TM
01400		Open procedures on knee joint; nos		4 + TM
01402		Total knee replacement		7 + TM
01404		Disarticulation at knee		5 + TM
01420		Cast apply, remove, repair knee		3 + TM
01430		Veins of knee and popliteal area; nos		3 + TM
01432		Arteriovenous fistula		6 + TM
01440		Arteries knee and popliteal area nos		5 + TM
01442		Popliteal thromboendarterectomy		8 + TM
01444		Popliteal excision and graft		8 + TM

LABOR AND EMPLOYMENT

Maximum Fee Allowance Schedule Office of Workers' Compensation				
CPT Code	Mod	Description	Global Days	Maximum Allowance
01462		Closed proc lwr leg, ankle, and foot		3 + TM
01464		Arthroscopic procedures ankle joint		3 + TM
01470		Nerves, muscles, etc, lower leg		3 + TM
01472		Repair ruptured achilles tendon,		5 + TM
01474		Gastrocnemius recession		5 + TM
01480		Open procedures bones lower leg		3 + TM
01482		Radical resection		4 + TM
01484		Osteotomy/osteoplasty tibia/fibula		4 + TM
01486		Total ankle replacement		7 + TM
01490		Lower leg cast, removal, or repair		3 + TM
01500		Arteries lower leg, inc bypass; nos		8 + TM
01502		Embolectomy, direct or catheter		6 + TM
01520		Veins of lower leg nos		3 + TM
01522		Venous thrombectomy, dir catheter		5 + TM
01610		Nerves, muscles, etc, shoulder		5 + TM
01620		Closed proc humeral head and neck		4 + TM
01622		Arthroscopic procedures shoulder		4 + TM
01630		Open procedures humeral head and neck		5 + TM
01634		Shoulder disarticulation		9 + TM
01636		Interthoracoscapular amputation		15 + TM
01638		Total shoulder replacement		10 + TM
01650		Arteries of shoulder and axilla nos		6 + TM
01652		Axillary-brachial aneurysm		10 + TM
01654		Bypass graft		8 + TM
01656		Axillaryfemoral bypass graft		10 + TM
01670		Procedures veins shoulder and axilla		4 + TM
01680		Shoulder cast, removal, repair nos		3 + TM
01682		Shoulder spica		4 + TM
01710		Nerves, muscles, etc, of upper arm		3 + TM
01712		Tenotomy, elbow to shoulder, open		5 + TM
01714		Tenoplasty, elbow to shoulder		5 + TM
01716		Tenodesis, rupt long tendon biceps		5 + TM
01730		Closed procedures humerus and elbow		3 + TM
01732		Arthroscopic procedures elbow joint		3 + TM
01740		Open procedures humerus and elbow nos		4 + TM
01742		Osteotomy of humerus		5 + TM
01744		Repair nonunion/malunion of humerus		5 + TM
01756		Radical procedures		6 + TM
01758		Excision cyst or tumor of humerus		5 + TM
01760		Total elbow replacement		7 + TM
01770		Arteries of upper arm and elbow; nos		6 + TM
01772		Embolectomy		6 + TM
01780		Veins of upper arm and elbow; nos		3 + TM
01782		Phleborrhaphy		4 + TM
01810		Nerves, muscles, etc, forearm/wrist		3 + TM
01820		Closed proc lwr arm, wrist or hand		3 + TM
01829		Anesth, dx wrist arthroscopy		3 + TM
01830		Open proc lwr arm, wrist or hand		3 + TM

Maximum Fee Allowance Schedule Office of Workers' Compensation				
CPT Code	Mod	Description	Global Days	Maximum Allowance
01832		Total wrist replacement		6 + TM
01840		Arteries forearm, wrist, and hand nos		6 + TM
01842		Embolectomy		6 + TM
01844		Vascular shunt, shunt revision		6 + TM
01850		Veins forearm, wrist, and hand nos		3 + TM
01852		Phleborrhaphy		4 + TM
01860		Forearm, wrist, or hand cast applic		3 + TM
01916		Arteriograms, needle carotid/vert		5 + TM
01920		Cardiac catheterization		7 + TM
01922		CAT/MRI		7 + TM
01924		Anes, ther interven rad, art		5 + TM
01925		Anes, ther interven rad, car		7 + TM
01926		Anes, tx interv rad hrt/cran		8 + TM
01930		Anes, ther interven rad, vei		5 + TM
01931		Anes, ther interven rad, tip		7 + TM
01932		Anes, tx interv rad, th vein		6 + TM
01933		Anes, tx interv rad, cran v		7 + TM
01935		Anesth, perc img dx sp proc		5 + TM
01936		Anesth, perc img tx sp proc		5 + TM
01951		Anesth, burn, less 4 percent		3 + TM
01952		Anesth, burn, 4-9 percent		5 + TM
01953		Anesth, burn, each 9 percent		1 + TM
01958		Anesth, antepartum manipul		5 + TM
01960		Anesth, vaginal delivery		5 + TM
01961		Anesth, cs delivery		7 + TM
01962		Anesth, emer hysterectomy		8 + TM
01963		Anesth, cs hysterectomy		8 + TM
01964		Anesth, abortion pro		4 + TM
01965		Anesth, inc/missed ab pro		4 + TM
01966		Anesth, induced ab procedure		4 + TM
01967		Anesth/analg, vag delivery		5 + TM
01968		Anes/analg cs deliver add-on		2 + TM
01969		Anesth/analg cs hyst add-on		5 + TM
01990		Harvest organ(s) brain dead patient		7 + TM
01991		Anesth nerve block/inj		3 + TM
01992		Anesth n block/inj prone		5 + TM
01996		Daily mgmt epidur/subarach drug adm		\$3
01999		Unlisted anesthesia procedre		BR

B. Table 2

CPT Code	Mod	Description	Global Days	Maximum Allowance	Non-Facility Maximum	Facility Maximum
10021		Fna w/o image		\$305		
10022		Fna w/image		\$278		
10040		Acne surgery	10	\$119		

Title 40, Part I

CPT Code	Mod	Description	Global Days	Maximum Allowance	Non-Facility Maximum	Facility Maximum
10060		Drainage of skin abscess	10	\$113		
10061		Drainage of skin abscess	10	\$226		
10080		Drainage of pilonidal cyst	10	\$154		
10081		Drainage of pilonidal cyst	10	\$260		
10120		Remove foreign body	10	\$121		
10121		Remove foreign body	10	\$266		
10140		Drainage of hematoma/fluid	10	\$143		
10160		Puncture drainage of lesion	10	\$112		
10180		Complex drainage, wound	10	\$243		
11000		Surgical cleansing of skin	0	\$96		
11001		Debride infected skin add-on		\$42		
11004		Debride genitalia & perineum		\$1,204		
11005		Debride abdom wall		\$1,627		
11006		Debride genit/per/abdom wall		\$1,466		
11008		Remove mesh from abd wall		\$570		
11010		Debride skin, fx.....	10	\$591		
11011		Debride skin/muscle, fx.	0	\$713		
11012		Debride skin/muscle/ bone, fx	0	\$994		
11042		Cleansing of skin/tissue	0	\$131		
11043		Cleansing of tissue/muscle	10	\$282		
11044		Cleansing tissue/muscle/bone	10	\$397		
11046		Deb musc/fascia add-on		\$148		
11047		Deb bone add-on		\$250		
11055		Trim skin lesion.....	0	\$40		
11056		Trim skin lesions, 2 to 4.	0	\$55		
11057		Trim skin lesions, over 4.	0	\$59		
11100		Biopsy of skin lesion	0	\$97		
11101		Biopsy, skin add-on...		\$56		
11200		Removal of skin tags	10	\$82		
11201		Remove skin tags add- on.		\$37		
11300		Shave skin lesion	0	\$78		
11301		Shave skin lesion	0	\$112		
11302		Shave skin lesion	0	\$144		
11303		Shave skin lesion	0	\$196		
11305		Shave skin lesion	0	\$89		
11306		Shave skin lesion	0	\$126		
11307		Shave skin lesion	0	\$154		
11308		Shave skin lesion	0	\$212		
11310		Shave skin lesion	0	\$105		
11311		Shave skin lesion	0	\$140		
11312		Shave skin lesion	0	\$172		
11313		Shave skin lesion	0	\$231		
11400		Removal of skin lesion	10	\$103		
11401		Removal of skin lesion	10	\$142		
11402		Removal of skin lesion	10	\$180		
11403		Removal of skin lesion	10	\$224		
11404		Removal of skin lesion	10	\$262		
11406		Removal of skin lesion	10	\$348		
11420		Removal of skin lesion	10	\$112		
11421		Removal of skin lesion	10	\$161		
11422		Removal of skin lesion	10	\$195		
11423		Removal of skin lesion	10	\$253		
11424		Removal of skin lesion	10	\$292		
11426		Removal of skin lesion	10	\$414		
11440		Removal of skin lesion	10	\$131		
11441		Removal of skin lesion	10	\$177		
11442		Removal of skin lesion	10	\$216		
11443		Removal of skin lesion	10	\$287		
11444		Removal of skin lesion	10	\$353		
11446		Removal of skin lesion	10	\$453		
11450		Removal, sweat gland lesion	90	\$404		
11451		Removal, sweat gland lesion	90	\$507		
11462		Removal, sweat gland lesion	90	\$364		
11463		Removal, sweat gland lesion	90	\$434		
11470		Removal, sweat gland lesion	90	\$448		
11471		Removal, sweat gland lesion	90	\$511		

LABOR AND EMPLOYMENT

CPT Code	Mod	Description	Global Days	Maximum Allowance	Non-Facility Maximum	Facility Maximum
11600		Removal of skin lesion	10	\$184		
11601		Removal of skin lesion	10	\$241		
11602		Removal of skin lesion	10	\$285		
11603		Removal of skin lesion	10	\$338		
11604		Removal of skin lesion	10	\$381		
11606		Removal of skin lesion	10	\$495		
11620		Removal of skin lesion	10	\$194		
11621		Removal of skin lesion	10	\$271		
11622		Removal of skin lesion	10	\$332		
11623		Removal of skin lesion	10	\$404		
11624		Removal of skin lesion	10	\$490		
11626		Removal of skin lesion	10	\$576		
11640		Removal of skin lesion	10	\$233		
11641		Removal of skin lesion	10	\$330		
11642		Removal of skin lesion	10	\$402		
11643		Removal of skin lesion	10	\$477		
11644		Removal of skin lesion	10	\$591		
11646		Removal of skin lesion	10	\$763		
11719		Trim nail(s).....	0	\$30		
11720		Debride nail, 1-5.....	0	\$49		
11721		Debride nail, 6 or more.	0	\$80		
11730		Removal of nail plate	0	\$115		
11732		Remove nail plate, add on.		\$60		
11740		Drain blood from under nail	0	\$56		
11750		Removal of nail bed	10	\$280		
11752		Remove nail bed/finger tip	10	\$393		
11755		Biopsy, nail unit	0	\$171		
11760		Reconstruction of nail bed	10	\$181		
11762		Reconstruction of nail bed	10	\$400		
11765		Excision of nail fold, toe	10	\$86		
11770		Removal of pilonidal lesion	10	\$402		
11771		Removal of pilonidal lesion	90	\$750		
11772		Removal of pilonidal lesion	90	\$863		
11900		Injection into skin lesions	0	\$56		
11901		Added skin lesion injections	0	\$88		
11920		Correct skin color defects			\$361	\$243
11921		Correct skin color defects			\$417	\$285
11922		Correct skin color defects		\$64		
11950		Therapy for contour defects	0	\$149		
11951		Therapy for contour defects	0	\$224		
11952		Therapy for contour defects	0	\$298		
11954		Therapy for contour defects	0	\$335		
11960		Insert tissue expander(s)	90	\$1,081		
11970		Replace tissue expander	90	\$1,187		
11971		Remove tissue expander(s)	90	\$442		
11976		Removal of contraceptive	0	\$300		
11980		Implant hormone pellet(s).		\$215		
11981		Insert drug implant device		\$279		
11982		Remove drug implant device		\$313		
11983		Remove/insert drug implant		\$436		
12001		Repair superficial wound(s)	10	\$161		
12002		Repair superficial wound(s)	10	\$189		
12004		Repair superficial wound(s)	10	\$243		
12005		Repair superficial wound(s)	10	\$313		
12006		Repair superficial wound(s)	10	\$396		
12007		Repair superficial wound(s)	10	\$430		
12011		Repair superficial wound(s)	10	\$178		
12013		Repair superficial wound(s)	10	\$216		
12014		Repair superficial wound(s)	10	\$262		
12015		Repair superficial wound(s)	10	\$347		
12016		Repair superficial wound(s)	10	\$448		
12017		Repair superficial wound(s)	10	\$590		
12018		Repair superficial wound(s)	10	\$787		
12020		Closure of split wound	10	\$279		
12021		Closure of split wound	10	\$179		
12031		Layer closure of wound(s)	10	\$205		

Title 40, Part I

CPT Code	Mod	Description	Global Days	Maximum Allowance	Non-Facility Maximum	Facility Maximum
12032		Layer closure of wound(s)	10	\$253		
12034		Layer closure of wound(s)	10	\$318		
12035		Layer closure of wound(s)	10	\$392		
12036		Layer closure of wound(s)	10	\$474		
12037		Layer closure of wound(s)	10	\$580		
12041		Layer closure of wound(s)	10	\$230		
12042		Layer closure of wound(s)	10	\$282		
12044		Layer closure of wound(s)	10	\$346		
12045		Layer closure of wound(s)	10	\$421		
12046		Layer closure of wound(s)	10	\$523		
12047		Layer closure of wound(s)	10	\$650		
12051		Layer closure of wound(s)	10	\$250		
12052		Layer closure of wound(s)	10	\$307		
12053		Layer closure of wound(s)	10	\$354		
12054		Layer closure of wound(s)	10	\$444		
12055		Layer closure of wound(s)	10	\$566		
12056		Layer closure of wound(s)	10	\$740		
12057		Layer closure of wound(s)	10	\$847		
13100		Repair of wound or lesion	10	\$307		
13101		Repair of wound or lesion	10	\$436		
13102		Repair wound/lesion add-on		\$227		
13120		Repair of wound or lesion	10	\$338		
13121		Repair of wound or lesion	10	\$514		
13122		Repair wound/lesion add-on		\$248		
13131		Repair of wound or lesion	10	\$421		
13132		Repair of wound or lesion	10	\$653		
13133		Repair wound/lesion add-on		\$349		
13150		Repair of wound or lesion	10	\$407		
13151		Repair of wound or lesion	10	\$510		
13152		Repair of wound or lesion	10	\$857		
13153		Repair wound/lesion add-on		\$388		
13160		Late closure of wound	90	\$952		
14000		Skin tissue rearrangement	90	\$653		
14001		Skin tissue rearrangement	90	\$941		
14020		Skin tissue rearrangement	90	\$812		
14021		Skin tissue rearrangement	90	\$1,169		
14040		Skin tissue rearrangement	90	\$1,034		
14041		Skin tissue rearrangement	90	\$1,391		
14060		Skin tissue rearrangement	90	\$1,193		
14061		Skin tissue rearrangement	90	\$1,641		
14301		Skin tissue rearrangement		\$2,262		
14302		Skin tissue rearrange add-on		\$468		
14350		Skin tissue rearrangement	90	\$1,145		
15002		Wound prep trk/arm/leg		\$722		
15003		Wound prep addl 100 cm		\$158		
15004		Wound prep f/n/hf/g		\$827		
15005		Wnd prep f/n/hf/g addl cm		\$261		
15040		Harvest cultured skin graft		\$532		
15050		Skin pinch graft procedure	90	\$424		
15100		Skin split graft.....	90	\$1,039		
15101		Skin split graft add- on		\$249		
15110		Epidrm autogrft trnk/arm/leg		\$1,810		
15111		Epidrm autogrft t/a/l add-on		\$233		
15115		Epidrm a-grft face/nck/hf/g		\$1,823		
15116		Epidrm a-grft f/n/hf/g addl		\$361		
15120		Skin split graft.....	90	\$1,208		
15121		Skin split graft add- on		\$410		
15130		Derm autograft trnk/arm/leg		\$1,414		
15131		Derm autograft t/a/l add-on		\$214		
15135		Derm autograft face/nck/hf/g		\$1,834		
15136		Derm autograft f/n/hf/g add		\$183		
15150		Cult skin grft t/arm/leg		\$1,435		
15151		Cult skin grft t/a/l addl		\$247		
15152		Cult skin graft t/a/l +%		\$348		
15155		Cult skin graft f/n/hf/g		\$1,434		
15156		Cult skin grft f/n/hfg add		\$373		

LABOR AND EMPLOYMENT

CPT Code	Mod	Description	Global Days	Maximum Allowance	Non-Facility Maximum	Facility Maximum
15157		Cult epiderm grft f/n/hfg +%		\$378		
15200		Skin full graft procedure	90	\$870		
15201		Skin full graft add-on		\$232		
15220		Skin full graft procedure	90	\$928		
15221		Skin full graft add-on		\$216		
15240		Skin full graft procedure	90	\$1,092		
15241		Skin full graft add-on		\$319		
15260		Skin full graft procedure	90	\$1,275		
15261		Skin full graft add-on		\$376		
15271		Skin sub graft trnk/arm/leg		\$297		
15272		Skin sub graft t/a/l add-on		\$56		
15273		Skin sub grft t/arm/lg child		\$611		
15274		Skn sub grft t/a/l child add		\$144		
15275		Skin sub graft face/nk/hf/g		\$319		
15276		Skin sub graft f/n/hf/g addl		\$70		
15277		Skn sub grft f/n/hf/g child		\$616		
15278		Skn sub grft f/n/hf/g ch add		\$169		
15350		Skin homograft.....	90	\$537		
15570		Form skin pedicle flap	90	\$1,051		
15572		Form skin pedicle flap	90	\$1,004		
15574		Form skin pedicle flap	90	\$992		
15576		Form skin pedicle flap	90	\$566		
15600		Skin graft procedure	90	\$474		
15610		Skin graft procedure	90	\$475		
15620		Skin graft procedure	90	\$577		
15630		Skin graft procedure	90	\$623		
15650		Transfer skin pedicle flap	90	\$682		
15731		Forehead flap w/vasc pedicle		\$2,399		
15732		Muscle-skin graft, head/neck	90	\$2,351		
15734		Muscle-skin graft, trunk	90	\$2,744		
15736		Muscle-skin graft, arm	90	\$2,441		
15738		Muscle-skin graft, leg	90	\$2,034		
15740		Island pedicle flap graft	90	\$1,520		
15750		Neurovascular pedicle graft	90	\$1,741		
15756		Free muscle flap, microvasc	90	\$4,826		
15757		Free skin flap, microvasc	90	\$4,835		
15758		Free fascial flap, microvasc	90	\$4,826		
15760		Composite skin graft	90	\$1,181		
15770		Derma-fat-fascia graft	90	\$1,081		
15775		Hair transplant punch grafts		\$596		
15776		Hair transplant punch grafts		\$824		
15777		Acellular derm matrix implt		\$442		
15780		Abrasion treatment of skin	90	\$594		
15781		Abrasion treatment of skin	90	\$625		
15782		Abrasion treatment of skin	90	\$390		
15783		Abrasion treatment of skin	90	\$439		
15786		Abrasion treatment of lesion	10	\$189		
15787		Abrasion, lesions, add on		\$41		
15788		Chemical peel, face, epiderm	90	\$321		
15789		Chemical peel, face, dermal	90	\$390		
15792		Chemical peel, nonfacial	90	\$206		
15793		Chemical peel, nonfacial	90	\$261		
15819		Plastic surgery, neck	90	\$1,257		
15820		Revision of lower eyelid	90	\$830		
15821		Revision of lower eyelid	90	\$952		
15822		Revision of upper eyelid	90	\$799		
15823		Revision of upper eyelid	90	\$1,060		
15824		Removal of forehead wrinkles	BR			
15825		Removal of neck wrinkles	BR			
15826		Removal of brow wrinkles		BR		
15828		Removal of face wrinkles		BR		
15829		Removal of skin wrinkles		BR		
15830		Exc skin abd		\$2,470		
15832		Excise excessive skin tissue	90	\$1,457		
15833		Excise excessive skin tissue	90	\$1,229		
15834		Excise excessive skin tissue	90	\$1,314		

Title 40, Part I

CPT Code	Mod	Description	Global Days	Maximum Allowance	Non-Facility Maximum	Facility Maximum
15835		Excise excessive skin tissue	90	\$1,359		
15836		Excise excessive skin tissue	90	\$1,113		
15837		Excise excessive skin tissue	90	\$1,055		
15838		Excise excessive skin tissue	90	\$949		
15839		Excise excessive skin tissue	90	\$838		
15840		Graft for face nerve palsy	90	\$2,130		
15841		Graft for face nerve palsy	90	\$2,914		
15842		Graft for face nerve palsy	90	\$4,789		
15845		Skin and muscle repair, face	90	\$2,129		
15850		Removal of sutures		\$176		
15851		Removal of sutures	0	\$84		
15852		Dressing change, not for burn	0	\$97		
15860		Test for blood flow in graft	0	\$252		
15876		Suction assisted lipectomy		BR		
15877		Suction assisted lipectomy		BR		
15878		Suction assisted lipectomy		BR		
15879		Suction assisted lipectomy		BR		
15920		Removal of tail bone ulcer	90	\$775		
15922		Removal of tail bone ulcer	90	\$1,157		
15931		Remove sacrum pressure sore	90	\$822		
15933		Remove sacrum pressure sore	90	\$1,274		
15934		Remove sacrum pressure sore	90	\$1,442		
15935		Remove sacrum pressure sore	90	\$1,881		
15936		Remove sacrum pressure sore	90	\$1,702		
15937		Remove sacrum pressure sore	90	\$2,061		
15940		Removal of pressure sore	90	\$883		
15941		Removal of pressure sore	90	\$1,316		
15944		Removal of pressure sore	90	\$1,505		
15945		Removal of pressure sore	90	\$1,738		
15946		Remove hip pressure sore.	90	\$2,841		
15950		Remove thigh pressure sore	90	\$735		
15951		Remove thigh pressure sore	90	\$1,332		
15952		Remove thigh pressure sore	90	\$1,323		
15953		Remove thigh pressure sore	90	\$1,582		
15956		Remove thigh pressure sore	90	\$2,408		
15958		Remove thigh pressure sore	90	\$2,507		
15999		Removal of pressure sore		BR		
16000		Initial treatment of burn(s)	0	\$90		
16020		Treatment of burn(s)	0	\$83		
16025		Treatment of burn(s)	0	\$166		
16030		Treatment of burn(s)	0	\$190		
16035		Incision of burn scab	90	\$478		
16036		Escharotomy addl incision		\$175		
17000		Destroy benign/primal lesion lesion	10	\$80		
17003		Destroy lesions, 2-14		\$28		
17004		Destroy lesions, 15 or more	10	\$365		
17106		Destruction of skin lesions	90	\$471		
17107		Destruction of skin lesions	90	\$931		
17108		Destruction of skin lesions	90	\$1,636		
17110		Destroy lesion, 1-14	10	\$84		
17111		Destroy lesion, 15 or more	10	\$120		
17250		Chemical cautery, tissue	0	\$63		
17260		Destruction of skin lesions	10	\$148		
17261		Destruction of skin lesions	10	\$187		
17262		Destruction of skin lesions	10	\$249		
17263		Destruction of skin lesions	10	\$298		
17264		Destruction of skin lesions	10	\$336		
17266		Destruction of skin lesions	10	\$418		
17270		Destruction of skin lesions	10	\$193		
17271		Destruction of skin lesions	10	\$238		
17272		Destruction of skin lesions	10	\$291		
17273		Destruction of skin lesions	10	\$342		
17274		Destruction of skin lesions	10	\$430		
17276		Destruction of skin lesions	10	\$502		
17280		Destruction of skin lesions	10	\$207		
17281		Destruction of skin lesions	10	\$279		

LABOR AND EMPLOYMENT

CPT Code	Mod	Description	Global Days	Maximum Allowance	Non-Facility Maximum	Facility Maximum
17282		Destruction of skin lesions	10	\$339		
17283		Destruction of skin lesions	10	\$416		
17284		Destruction of skin lesions	10	\$496		
17286		Destruction of skin lesions	10	\$660		
17304		Chemosurgery of skin lesion	0	\$891		
17311		Mohs 1 stage h/n/hf/g		\$1,352		
17312		Mohs addl stage		\$806		
17313		Mohs 1 stage t/a/l		\$1,233		
17314		Mohs addl stage t/a/l		\$747		
17315		Mohs surg addl block		\$163		
17340		Cryotherapy of skin	10	\$73		
17360		Skin peel therapy	10	\$120		
17380		Hair removal by electrolysis		BR		
17999		Skin tissue procedure		BR		
19000		Drainage of breast lesion	0	\$91		
19001		Drain breast lesion add-on.		\$64		
19020		Incision of breast lesion	90	\$358		
19030		Injection for breast X-ray	0	\$147		
19100		Biopsy of breast	0	\$145		
19101		Biopsy of breast	10	\$419		
19102		Bx breast percut w/image		\$428		
19103		Bx breast percut w/device		\$1,108		
19105		Cryosurg ablate fa each		\$6,103		
19110		Nipple exploration	90	\$505		
19112		Excise breast duct fistula	90	\$440		
19120		Removal of breast lesion	90	\$648		
19125		Excision, breast lesion	90	\$663		
19126		Excision, addl breast lesion		\$326		
19160		Removal of breast tissue	90	\$826		
19260		Removal of chest wall lesion	90	\$1,416		
19271		Revision of chest wall	90	\$2,392		
19272		Extensive chest wall surgery	90	\$2,452		
19290		Place needle wire, breast	0	\$126		
19291		Place needle wire, breast.		\$86		
19295		Place breast clip percut		\$182		
19296		Place po breast cath for rad		\$8,412		
19297		Place breast cath for rad		\$194		
19298		Place breast rad tube/caths		\$2,245		
19300		Removal of breast tissue		\$1,080		
19301		Partical mastectomy		\$1,345		
19302		P-mastectomy w/ln removal		\$1,855		
19303		Mast simple complete		\$2,084		
19304		Mast subq		\$1,189		
19305		Mast radical		\$2,339		
19306		Mast rad urban type		\$2,482		
19307		Mast mod rad		\$2,469		
19316		Suspension of breast	90	\$1,794		
19318		Reduction of large breast	90	\$2,105		
19324		Enlarge breast	90	\$674		
19325		Enlarge breast with implant	90	\$1,066		
19328		Removal of breast implant	90	\$695		
19330		Removal of implant material	90	\$836		
19340		Immediate breast prosthesis		\$1,284		
19342		Delayed breast prosthesis	90	\$1,662		
19350		Breast reconstruction	90	\$1,181		
19355		Correct inverted nipple(s)	90	\$934		
19357		Breast reconstruction	90	\$2,212		
19361		Breast reconstruction	90	\$2,961		
19364		Breast reconstruction	90	\$3,388		
19366		Breast reconstruction	90	\$2,791		
19367		Breast reconstruction	90	\$3,412		
19368		Breast reconstruction	90	\$3,861		
19369		Breast reconstruction	90	\$3,688		
19370		Surgery of breast capsule	90	\$1,058		
19371		Removal of breast capsule	90	\$1,295		
19380		Revise breast reconstruction	90	\$1,297		



Title 40, Part I

CPT Code	Mod	Description	Global Days	Maximum Allowance	Non-Facility Maximum	Facility Maximum
19396		Design custom breast implant	0		\$619	\$312
19499		Breast surgery procedure		BR		
20005		Incision of deep abscess	10	\$363		
20100		Explore wound, neck...	10	\$1,143		
20101		Explore wound, chest..	10	\$372		
20102		Explore wound, abdomen	10	\$458		
20103		Explore wound, extremity	10	\$615		
20150		Excise epiphyseal bar	90	\$1,901		
20200		Muscle biopsy	0	\$196		
20205		Deep muscle biopsy	0	\$323		
20206		Needle biopsy, muscle	0	\$148		
20220		Bone biopsy, trocar/needle	0	\$189		
20225		Bone biopsy, trocar/needle	0	\$322		
20240		Bone biopsy, excisional	10	\$396		
20245		Bone biopsy, excisional	10	\$545		
20250		Open bone biopsy	10	\$741		
20251		Open bone biopsy	10	\$844		
20500		Injection of sinus tract	10	\$112		
20501		Inject sinus tract for X-ray	0	\$77		
20520		Removal of foreign body	10	\$184		
20525		Removal of foreign body	10	\$410		
20526		Ther injection carp tunnel		\$156		
20527		Inj dupuytren cord w/enzyme		\$157		
20550		Inj tendon/ligament/cyst	0	\$91		
20551		Inj tendon origin/insertion		\$123		
20552		Inj trigger point 1/2 muscl		\$113		
20553		Inject trigger points => 3		\$130		
20555		Place ndl musc/tis for rt		\$682		
20560		Needle Insertion w/o Injection 1 or 2 Muscles			\$36.95	\$24.04
20561		Needle Insertion w/o Injection 3 or more Muscles			\$55.06	\$36.40
20600		Drain/inject joint/bursa	0	\$84		
20605		Drain/inject joint/bursa	0	\$84		
20610		Drain/inject joint/bursa	0	\$92		
20612		Aspirate/inj ganglion cyst		\$124		
20615		Treatment of bone cyst	10	\$197		
20650		Insert and remove bone pin	10	\$233		
20660		Apply, remove fixation device	0	\$304		
20661		Application of head brace	90	\$619		
20662		Application of pelvis brace	90	\$927		
20663		Application of thigh brace	90	\$728		
20664		Halo brace application	90	\$940		
20665		Removal of fixation device	10	\$130		
20670		Removal of support implant	10	\$180		
20680		Removal of support implant	90	\$503		
20690		Apply bone fixation device	90	\$550		
20692		Apply bone fixation device	90	\$907		
20693		Adjust bone fixation device	90	\$590		
20694		Remove bone fixation device	90	\$483		
20696		Comp multiplane ext fixation		\$2,366		
20697		Comp ext fixate strut change		\$4,357		
20802		Replantation, arm, complete	90	\$5,778		
20805		Replant, forearm, complete	90	\$7,222		
20808		Replantation hand, complete	90	\$8,745		
20816		Replantation digit, complete	90	\$4,710		
20822		Replantation digit, complete	90	\$3,961		
20824		Replantation thumb, complete	90	\$4,633		
20827		Replantation thumb, complete	90	\$4,061		
20838		Replantation foot, complete	90	\$5,911		
20900		Removal of bone for graft	90	\$586		
20902		Removal of bone for graft	90	\$885		
20910		Remove cartilage for graft	90	\$419		
20912		Remove cartilage for graft	90	\$801		
20920		Removal of fascia for graft	90	\$658		
20922		Removal of fascia for graft	90	\$789		
20924		Removal of tendon for graft	90	\$874		

LABOR AND EMPLOYMENT

CPT Code	Mod	Description	Global Days	Maximum Allowance	Non-Facility Maximum	Facility Maximum
20926		Removal of tissue for graft	90	\$567		
20930		Spinal bone allograft		BR		
20931		Spinal bone allograft		\$263		
20936		Spinal bone autograft		BR		
20937		Spinal bone autograft		\$402		
20938		Spinal bone autograft		\$434		
20950		Record fluid pressure, muscle	0	\$178		
20955		Microvascular fibula graft	90	\$5,321		
20956		Iliac bone graft, microvasc	90	\$5,021		
20957		Mt bone graft, microvasc	90	\$5,079		
20962		Other bone graft, microvasc	90	\$5,010		
20969		Bone/skin graft, microvasc	90	\$6,207		
20970		Bone/skin graft, iliac crest	90	\$6,061		
20972		Bone-skin graft, metatarsal	90	\$4,522		
20973		Bone-skin graft, great toe	90	\$5,887		
20974		Electrical bone stimulation	0	\$325		
20975		Electrical bone stimulation	0	\$460		
20979		US bone stimulation			\$110	\$68
20982		Ablate bone tumor(s) perq		\$7,687		
20985		Cptr-asst dir ms px		\$307		
20999		Musculoskeletal surgery		BR		
21010		Incision of jaw joint	90	\$1,432		
21011		Exc face les sc < 2 cm		\$730		
21012		Exc face les sbq 2 cm/>		\$703		
21013		Exc face tum deep < 2 cm		\$1,095		
21014		Exc face tum deep 2 cm/>		\$1,090		
21015		Resection of facial tumor	90	\$877		
21016		Resect face tum 2 cm/>		\$2,172		
21025		Excision of bone, lower jaw	90	\$677		
21026		Excision of facial bone(s)	90	\$563		
21029		Contour of face bone lesion	90	\$1,219		
21030		Removal of face bone lesion	90	\$757		
21031		Remove exostosis, mandible	90	\$425		
21032		Remove exostosis, maxilla	90	\$602		
21034		Removal of face bone lesion	90	\$1,627		
21040		Removal of jaw bone lesion	90	\$355		
21044		Removal of jaw bone lesion	90	\$1,539		
21045		Extensive jaw surgery	90	\$2,161		
21046		Remove mandible cyst complex		\$2,312		
21047		Excise lwr jaw cyst w/repair		\$2,739		
21048		Remove maxilla cyst complex		\$2,372		
21049		Excis uppr jaw cyst w/repair		\$2,590		
21050		Removal of jaw joint	90	\$1,662		
21060		Remove jaw joint cartilage	90	\$1,571		
21070		Remove coronoid process	90	\$1,083		
21073		Mnpj of tmj w/anesth		\$812		
21076		Prepare face/oral prosthesis	10	\$2,008		
21077		Prepare face/oral prosthesis	90	\$5,049		
21079		Prepare face/oral prosthesis	90	\$3,548		
21080		Prepare face/oral prosthesis	90		\$3,899	\$3,206
21081		Prepare face/oral prosthesis	90		\$3,593	\$2,935
21082		Prepare face/oral prosthesis	90		\$3,403	\$2,762
21083		Prepare face/oral prosthesis	90		\$3,172	\$2,492
21084		Prepare face/oral prosthesis	90		\$3,703	\$2,969
21085		Prepare face/oral prosthesis	10		\$1,707	\$1,313
21086		Prepare face/oral prosthesis	90		\$3,825	\$3,192
21087		Prepare face/oral prosthesis	90		\$3,808	\$3,159
21088		Prepare face/oral prosthesis	90	BR		
21089		Prepare face/oral prosthesis	90	BR		
21100		Maxillofacial fixation	90	\$369		
21110		Interdental fixation	90	\$781		
21116		Injection, jaw joint X-ray	0	\$114		
21120		Reconstruction of chin	90	\$620		
21121		Reconstruction of chin	90	\$975		
21122		Reconstruction of chin	90	\$1,074		
21123		Reconstruction of chin	90	\$1,404		

Title 40, Part I

CPT Code	Mod	Description	Global Days	Maximum Allowance	Non-Facility Maximum	Facility Maximum
21125		Augmentation lower jaw bone	90	\$813		
21127		Augmentation lower jaw bone	90	\$1,364		
21137		Reduction of forehead	90	\$1,613		
21138		Reduction of forehead	90	\$1,876		
21139		Reduction of forehead	90	\$2,293		
21141		Reconstruct midface, lefort	90	\$2,359		
21142		Reconstruct midface, lefort	90	\$2,452		
21143		Reconstruct midface, lefort	90	\$2,548		
21145		Reconstruct midface, lefort	90	\$2,513		
21146		Reconstruct midface, lefort	90	\$2,608		
21147		Reconstruct midface, lefort	90	\$2,728		
21150		Reconstruct midface, lefort	90	\$3,494		
21151		Reconstruct midface, lefort	90	\$3,951		
21154		Reconstruct midface, lefort	90	\$4,626		
21155		Reconstruct midface, lefort	90	\$4,575		
21159		Reconstruct midface, lefort	90	\$5,158		
21160		Reconstruct midface, lefort	90	\$5,420		
21172		Reconstruct orbit/forehead	90	\$3,854		
21175		Reconstruct orbit/forehead	90	\$4,745		
21179		Reconstruct entire forehead	90	\$3,011		
21180		Reconstruct entire forehead	90	\$3,258		
21181		Contour cranial bone lesion	90	\$1,500		
21182		Reconstruct cranial bone	90	\$4,075		
21183		Reconstruct cranial bone	90	\$4,905		
21184		Reconstruct cranial bone	90	\$4,958		
21188		Reconstruction of midface	90	BR		
21193		Reconstruct lower jaw bone	90	\$2,171		
21194		Reconstruct lower jaw bone	90	\$2,460		
21195		Reconstruct lower jaw bone	90	\$2,206		
21196		Reconstruct lower jaw bone	90	\$2,345		
21198		Reconstruct lower jaw bone	90	\$2,118		
21199		Reconstr lwr jaw w/advance	90	\$2,142		
21206		Reconstruct upper jaw bone	90	\$1,748		
21208		Augmentation of facial bones	90	\$1,550		
21209		Reduction of facial bones	90	\$824		
21210		Face bone graft	90	\$1,635		
21215		Lower jaw bone graft	90	\$1,809		
21230		Rib cartilage graft	90	\$1,567		
21235		Ear cartilage graft	90	\$1,091		
21240		Reconstruction of jaw joint	90	\$2,560		
21242		Reconstruction of jaw joint	90	\$2,607		
21243		Reconstruction of jaw joint	90	\$2,482		
21244		Reconstruction of lower jaw	90	\$2,132		
21245		Reconstruction of jaw	90	\$1,689		
21246		Reconstruction of jaw	90	\$1,524		
21247		Reconstruct lower jaw bone	90	\$3,575		
21248		Reconstruction of jaw	90	\$2,246		
21249		Reconstruction of jaw	90	\$3,926		
21255		Reconstruct lower jaw bone	90	\$2,641		
21256		Reconstruction of orbit	90	\$2,558		
21260		Revise eye sockets	90	\$2,609		
21261		Revise eye sockets	90	\$3,459		
21263		Revise eye sockets	90	\$4,490		
21267		Revise eye sockets	90	\$2,435		
21268		Revise eye sockets	90	\$2,927		
21270		Augmentation cheek bone	90	\$1,636		
21275		Revision orbitofacial bones	90	\$1,466		
21280		Revision of eyelid	90	\$952		
21282		Revision of eyelid	90	\$788		
21295		Revision of jaw muscle/bone	90	\$179		
21296		Revision of jaw muscle/bone	90	\$553		
21299		Cranio/maxillofacial surgery		BR		
21310		Treatment of nose fracture	0	\$109		
21315		Treatment of nose fracture	10	\$243		
21320		Treatment of nose fracture	10	\$331		
21325		Repair of nose fracture	90	\$577		

LABOR AND EMPLOYMENT

CPT Code	Mod	Description	Global Days	Maximum Allowance	Non-Facility Maximum	Facility Maximum
21330		Repair of nose fracture	90	\$874		
21335		Repair of nose fracture	90	\$1,511		
21336		Repair nasal septal fracture	90	\$706		
21337		Repair nasal septal fracture	90	\$405		
21338		Repair nasoethmoid fracture	90	\$830		
21339		Repair nasoethmoid fracture	90	\$1,087		
21340		Repair of nose fracture	90	\$1,417		
21343		Repair of sinus fracture	90	\$1,582		
21344		Repair of sinus fracture	90	\$2,030		
21345		Repair of nose/jaw fracture	90	\$1,157		
21346		Repair of nose/jaw fracture	90	\$1,441		
21347		Repair of nose/jaw fracture	90	\$1,670		
21348		Repair of nose/jaw fracture	90	\$2,064		
21355		Repair cheek bone fracture	10	\$372		
21356		Repair cheek bone fracture	10	\$793		
21360		Repair cheek bone fracture	90	\$1,006		
21365		Repair cheek bone fracture	90	\$1,979		
21366		Repair cheek bone fracture	90	\$2,198		
21385		Repair eye socket fracture	90	\$1,365		
21386		Repair eye socket fracture	90	\$1,337		
21387		Repair eye socket fracture	90	\$1,237		
21390		Repair eye socket fracture	90	\$1,610		
21395		Repair eye socket fracture	90	\$1,618		
21400		Treat eye socket fracture	90	\$228		
21401		Repair eye socket fracture	90	\$421		
21406		Repair eye socket fracture	90	\$885		
21407		Repair eye socket fracture	90	\$1,127		
21408		Repair eye socket fracture	90	\$1,490		
21421		Treat mouth roof fracture	90	\$819		
21422		Repair mouth roof fracture	90	\$1,329		
21423		Repair mouth roof fracture	90	\$1,466		
21431		Treat craniofacial fracture	90	\$943		
21432		Repair craniofacial fracture	90	\$1,109		
21433		Repair craniofacial fracture	90	\$3,097		
21435		Repair craniofacial fracture	90	\$2,212		
21436		Repair craniofacial fracture	90	\$3,039		
21440		Repair dental ridge fracture	90	\$416		
21445		Repair dental ridge fracture	90	\$829		
21450		Treat lower jaw fracture	90	\$416		
21451		Treat lower jaw fracture	90	\$857		
21452		Treat lower jaw fracture	90	\$242		
21453		Treat lower jaw fracture	90	\$876		
21454		Treat lower jaw fracture	90	\$1,414		
21461		Repair lower jaw fracture	90	\$1,434		
21462		Repair lower jaw fracture	90	\$1,617		
21465		Repair lower jaw fracture	90	\$1,455		
21470		Repair lower jaw fracture	90	\$2,341		
21480		Reset dislocated jaw	0	\$117		
21485		Reset dislocated jaw	90	\$433		
21490		Repair dislocated jaw	90	\$1,268		
21493		Treat hyoid bone fracture	90	\$201		
21494		Repair hyoid bone fracture	90	\$993		
21495		Repair hyoid bone fracture	90	\$754		
21497		Interdental wiring	90	\$563		
21499		Head surgery procedure		BR		
21501		Drain neck/chest lesion	90	\$397		
21502		Drain chest lesion	90	\$808		
21510		Drainage of bone lesion	90	\$663		
21550		Biopsy of neck/chest	10	\$211		
21552		Exc neck les sc 3 cm/>		\$927		
21554		Exc neck tum deep 5 cm/>		\$1,517		
21555		Remove lesion neck/chest	90	\$421		
21556		Remove lesion neck/chest	90	\$689		
21557		Remove tumor, neck or chest	90	\$1,308		
21558		Resect neck tum 5 cm/>		\$2,807		
21600		Partial removal of rib	90	\$825		

Title 40, Part I

CPT Code	Mod	Description	Global Days	Maximum Allowance	Non-Facility Maximum	Facility Maximum
21610		Partial removal of rib	90	\$1,025		
21615		Removal of rib.....	90	\$1,532		
21616		Removal of rib and nerves	90	\$1,407		
21620		Partial removal of sternum	90	\$1,000		
21627		Sternal debridement	90	\$850		
21630		Extensive sternum surgery.	90	\$2,374		
21632		Extensive sternum surgery	90	\$2,150		
21685		Hyoid myotomy & suspension		\$2,118		
21700		Revision of neck muscle	90	\$745		
21705		Revision of neck muscle/rib	90	\$1,050		
21720		Revision of neck muscle	90	\$694		
21725		Revision of neck muscle	90	\$859		
21740		Reconstruction of sternum	90	\$1,844		
21750		Repair of sternum separation	90	\$1,333		
21800		Treatment of rib fracture	90	\$124		
21805		Treatment of rib fracture	90	\$293		
21810		Treatment of rib fracture(s)	90	\$1,035		
21820		Treat sternum fracture	90	\$194		
21825		Repair sternum fracture	90	\$1,051		
21899		Neck/chest surgery procedure		BR		
21920		Biopsy soft tissue of back	10	\$206		
21925		Biopsy soft tissue of back	90	\$460		
21930		Remove lesion, back or flank	90	\$691		
21931		Exc back les sc 3 cm/>		\$976		
21932		Exc back tum deep < 5 cm		\$1,371		
21933		Exc back tum deep 5 cm/>		\$1,535		
21935		Remove tumor of back	90	\$1,770		
21936		Resect back tum 5 cm/>		\$2,919		
22010		I&d p-spine c/t/cerv-thor		\$1,967		
22015		I&d p-spine l/s/l		\$1,930		
22100		Remove part of neck vertebra	90	\$1,309		
22101		Remove part, thorax vertebra	90	\$1,129		
22102		Remove part, lumbar vertebra	90	\$976		
22103		Remove extra spine segment		\$335		
22110		Remove part of neck vertebra	90	\$1,708		
22112		Remove part, thorax vertebra	90	\$1,637		
22114		Remove part, lumbar vertebra	90	\$1,417		
22206		Cut spine 3 col thor		\$4,913		
22207		Cut spine 3 col lumb		\$4,981		
22208		Cut spine 3 col addl seg		\$1,226		
22210		Revision of neck spine	90	\$2,867		
22212		Revision of thorax spine	90	\$2,708		
22214		Revision of lumbar spine	90	\$2,544		
22216		Revise, extra spine segment		\$818		
22220		Revision of neck spine	90	\$2,839		
22222		Revision of thorax spine	90	\$2,502		
22224		Revision of lumbar spine	90	\$2,653		
22226		Revise, extra spine segment		\$819		
22305		Treat spine process fracture	90	\$329		
22310		Treat spine fracture..	90	\$426		
22315		Treat spine fracture..	90	\$1,120		
22318		Treat odontoid fx w/o graft	90	\$3,400		
22319		Treat odontoid fx w/ graft	90	\$3,805		
22325		Treat spine fracture..	90	\$2,061		
22326		Treat neck spine fracture	90	\$2,678		
22327		Treat thorax spine fracture	90	\$2,619		
22328		Treat each add spine fx		\$656		
22505		Manipulation of spine	10	\$230		
22520		Percut vertebroplasty thor		\$4,580		
22521		Percut vertebroplasty lumb		\$4,587		
22522		Percut vertebroplasty addl		\$464		
22523		Percut kyphoplasty thor		\$15,722		
22524		Percut kyphoplasty lumbar		\$15,598		
22525		Percut kyphoplasty add-on		\$9,755		
22526		Idet single level		\$4,833		
22527		Idet 1 or more levels		\$3,985		

LABOR AND EMPLOYMENT

CPT Code	Mod	Description	Global Days	Maximum Allowance	Non-Facility Maximum	Facility Maximum
22532		Lat thorax spine fusion		\$3,715		
22533		Lat lumbar spine fusion		\$3,502		
22534		Lat thor/lumb addl seg		\$756		
22548		Neck spine fusion.....	90	\$3,611		
22551		Neck spine fuse&remov bel c2		\$3,574		
22552		Addl neck spine fusion		\$820		
22554		Neck spine fusion.....	90	\$2,850		
22556		Thorax spine fusion...	90	\$3,348		
22558		Lumbar spine fusion...	90	\$3,150		
22585		Additional spinal fusion		\$798		
22590		Spine & skull spinal fusion	90	\$3,102		
22595		Neck spinal fusion.....	90	\$3,021		
22600		Neck spine fusion.....	90	\$2,531		
22610		Thorax spine fusion...	90	\$2,485		
22612		Lumbar spine fusion...	90	\$3,083		
22614		Spine fusion, extra segment		\$884		
22630		Lumbar spine fusion...	90	\$2,945		
22632		Spine fusion, extra segment		\$745		
22633		Lumbar spine fusion combined		\$3,842		
22634		Spine fusion extra segment		\$1,037		
22800		Fusion of spine.....	90	\$2,850		
22802		Fusion of spine.....	90	\$4,383		
22804		Fusion of spine.....	90	\$4,809		
22808		Fusion of spine.....	90	\$3,368		
22810		Fusion of spine.....	90	\$3,677		
22812		Fusion of spine.....	90	\$4,352		
22818		Kyphectomy, 1-2 segments	90	\$4,421		
22819		Kyphectomy, 3 or more	90	\$4,781		
22830		Exploration of spinal fusion	90	\$1,803		
22840		Insert spine fixation device		\$1,408		
22841		Insert spine fixation device		BR		
22842		Insert spine fixation device		\$1,457		
22843		Insert spine fixation device		\$1,652		
22844		Insert spine fixation device		\$2,015		
22845		Insert spine fixation device		\$1,343		
22846		Insert spine fixation device		\$1,524		
22847		Insert spine fixation device		\$1,691		
22848		Insert pelv fixation device		\$876		
22849		Reinsert spinal fixation	90	\$1,882		
22850		Remove spine fixation device	90	\$1,391		
22851		Apply spine prosth device		\$974		
22852		Remove spine fixation device	90	\$1,400		
22855		Remove spine fixation device	90	\$1,260		
22856		Cerv artific diskectomy		\$3,470		
22857		Lumbar artif diskectomy		\$3,413		
22861		Revise cerv artific disc		\$4,137		
22862		Revise lumbar artif disc		\$4,481		
22864		Remove cerv artif disc		\$4,070		
22865		Remove lumb artif disc		\$4,266		
22899		Spine surgery procedure		BR		
22900		Remove abdominal wall lesion	90	\$721		
22901		Exc abdl tum deep 5 cm/>		\$1,381		
22902		Exc abd les sc < 3 cm		\$899		
22903		Exc abd les sc 3 cm/>		\$903		
22904		Resect abd tum < 5 cm		\$2,184		
22905		Resect abd tum 5 cm/>		\$2,771		
22999		Abdomen surgery procedure		BR		
23000		Removal of calcium deposits	90	\$619		
23020		Release shoulder joint	90	\$1,249		
23030		Drain shoulder lesion	10	\$402		
23031		Drain shoulder bursa	10	\$230		
23035		Drain shoulder bone lesion	90	\$1,237		
23040		Exploratory shoulder surgery	90	\$1,424		
23044		Exploratory shoulder surgery	90	\$1,103		
23065		Biopsy shoulder tissues	10	\$212		
23066		Biopsy shoulder tissues	90	\$374		

Title 40, Part I

CPT Code	Mod	Description	Global Days	Maximum Allowance	Non-Facility Maximum	Facility Maximum
23071		Exc shoulder les sc 3 cm/>		\$867		
23073		Exc shoulder tum deep 5 cm/>		\$1,436		
23075		Removal of shoulder lesion	10	\$339		
23076		Removal of shoulder lesion	90	\$801		
23077		Remove tumor of shoulder	90	\$1,657		
23078		Resect shoulder tum 5 cm/>		\$2,949		
23100		Biopsy of shoulder joint	90	\$992		
23101		Shoulder joint surgery	90	\$924		
23105		Remove shoulder joint lining	90	\$1,331		
23106		Incision of collarbone joint	90	\$848		
23107		Explore,treat shoulder joint	90	\$1,368		
23120		Partial removal, collarbone	90	\$850		
23125		Removal of collarbone	90	\$1,321		
23130		Remove shoulder bone, part	90	\$1,135		
23140		Removal of bone lesion	90	\$802		
23145		Removal of bone lesion	90	\$1,274		
23146		Removal of bone lesion	90	\$962		
23150		Removal of humerus lesion	90	\$1,094		
23155		Removal of humerus lesion	90	\$1,399		
23156		Removal of humerus lesion	90	\$1,195		
23170		Remove collarbone lesion	90	\$840		
23172		Remove shoulder blade lesion	90	\$859		
23174		Remove humerus lesion	90	\$1,308		
23180		Remove collar bone lesion	90	\$1,098		
23182		Remove shoulder blade lesion	90	\$1,222		
23184		Remove humerus lesion	90	\$1,475		
23190		Partial removal of scapula	90	\$980		
23195		Removal of head of humerus	90	\$1,371		
23200		Removal of collarbone	90	\$1,520		
23210		Removal of shoulder blade	90	\$1,545		
23220		Partial removal of humerus.	90	\$2,035		
23330		Remove shoulder foreign body	10	\$172		
23331		Remove shoulder foreign body	90	\$804		
23332		Remove shoulder foreign body	90	\$1,632		
23350		Injection for shoulder X-ray	0	\$112		
23395		Muscle transfer, shoulder/arm	90	\$2,127		
23397		Muscle transfers	90	\$2,233		
23400		Fixation of shoulder blade	90	\$1,733		
23405		Incision of tendon & muscle	90	\$1,195		
23406		Incise tendon(s) & muscle(s)	90	\$1,545		
23410		Repair of tendon(s)...	90	\$1,776		
23412		Repair of tendon(s)	90	\$1,998		
23415		Release of shoulder ligament	90	\$1,099		
23420		Repair of shoulder....	90	\$2,098		
23430		Repair biceps tendon..	90	\$1,345		
23440		Remove/transplant tendon	90	\$1,376		
23450		Repair shoulder capsule	90	\$1,968		
23455		Repair shoulder capsule	90	\$2,230		
23460		Repair shoulder capsule	90	\$2,211		
23462		Repair shoulder capsule	90	\$2,282		
23465		Repair shoulder capsule	90	\$2,254		
23466		Repair shoulder capsule	90	\$2,232		
23470		Reconstruct shoulder joint	90	\$2,530		
23472		Reconstruct shoulder joint	90	\$2,749		
23480		Revision of collarbone	90	\$1,286		
23485		Revision of collarbone	90	\$1,834		
23490		Reinforce clavicle	90	\$1,564		
23491		Reinforce shoulder bones	90	\$2,033		
23500		Treat clavicle fracture	90	\$270		
23505		Treat clavicle fracture	90	\$460		
23515		Repair clavicle fracture	90	\$1,067		
23520		Treat clavicle dislocation	90	\$255		
23525		Treat clavicle dislocation	90	\$400		
23530		Repair clavicle dislocation	90	\$1,027		
23532		Repair clavicle dislocation	90	\$1,133		
23540		Treat clavicle dislocation	90	\$272		

LABOR AND EMPLOYMENT

CPT Code	Mod	Description	Global Days	Maximum Allowance	Non-Facility Maximum	Facility Maximum
23545		Treat clavicle dislocation	90	\$378		
23550		Repair clavicle dislocation	90	\$1,176		
23552		Repair clavicle dislocation	90	\$1,153		
23570		Treat shoulder blade fracture	90	\$287		
23575		Treat shoulder blade fracture	90	\$500		
23585		Repair scapula fracture	90	\$1,232		
23600		Treat humerus fracture	90	\$430		
23605		Treat humerus fracture	90	\$714		
23615		Repair humerus fracture	90	\$1,478		
23616		Repair humerus fracture	90	\$3,238		
23620		Treat humerus fracture	90	\$431		
23625		Treat humerus fracture	90	\$571		
23630		Treat humerus fracture	90	\$1,171		
23650		Treat shoulder dislocation	90	\$395		
23655		Treat shoulder dislocation	90	\$540		
23660		Repair shoulder dislocation	90	\$1,244		
23665		Treat dislocation/ fracture	90	\$637		
23670		Treat dislocation/ fracture	90	\$1,278		
23675		Treat dislocation/fracture	90	\$718		
23680		Repair dislocation/fracture	90	\$1,686		
23700		Fixation of shoulder	10	\$347		
23800		Fusion of shoulder joint	90	\$2,233		
23802		Fusion of shoulder joint.	90	\$2,317		
23900		Amputation of arm & girdle	90	\$2,362		
23920		Amputation at shoulder joint	90	\$2,123		
23921		Amputation follow-up surgery	90	\$712		
23929		Shoulder surgery procedure		BR		
23930		Drainage of arm lesion	10	\$328		
23931		Drainage of arm bursa	10	\$240		
23935		Drain arm/elbow bone lesion	90	\$781		
24000		Exploratory elbow surgery	90	\$946		
24006		Release elbow joint	90	\$1,204		
24065		Biopsy arm/elbow soft tissue	10	\$207		
24066		Biopsy arm/elbow soft tissue	90	\$639		
24071		Exc arm/elbow les sc 3 cm/>	90	\$843		
24073		Exc arm/elbow les sc 3 cm/>	90	\$1,438		
24075		Ex arm/elbow tum deep 5 cm/>	90	\$433		
24076		Remove arm/elbow lesion	90	\$734		
24077		Remove tumor of arm/elbow	90	\$1,617		
24079		Resect arm/elbow tum 5 cm/>		\$2,761		
24100		Biopsy elbow joint lining.	90	\$704		
24101		Explore/treat elbow joint	90	\$1,071		
24102		Remove elbow joint lining	90	\$1,279		
24105		Removal of elbow bursa	90	\$555		
24110		Remove humerus lesion	90	\$1,132		
24115		Remove/graft bone lesion	90	\$1,267		
24116		Remove/graft bone lesion	90	\$1,580		
24120		Remove elbow lesion	90	\$946		
24125		Remove/graft bone lesion	90	\$977		
24126		Remove/graft bone lesion	90	\$1,159		
24130		Removal of head of radius	90	\$974		
24134		Removal of arm bone lesion	90	\$1,339		
24136		Remove radius bone lesion	90	\$1,206		
24138		Remove elbow bone lesion	90	\$1,048		
24140		Partial removal of arm bone	90	\$1,451		
24145		Partial removal of radius	90	\$1,116		
24147		Partial removal of elbow	90	\$1,125		
24149		Radical resection of elbow	90	\$1,992		
24150		Extensive humerus surgery	90	\$2,035		
24151		Extensive humerus surgery	90	\$2,165		
24152		Extensive radius surgery	90	\$1,237		
24155		Removal of elbow joint	90	\$1,669		
24160		Remove elbow joint implant	90	\$925		
24164		Remove radius head implant	90	\$865		
24200		Removal of arm foreign body	10	\$166		
24201		Removal of arm foreign body	90	\$621		



Title 40, Part I

CPT Code	Mod	Description	Global Days	Maximum Allowance	Non-Facility Maximum	Facility Maximum
24220		Injection for elbow X-ray	0	\$133		
24300		Manipulate elbow w/anesth		\$853		
24301		Muscle/tendon transfer	90	\$1,339		
24305		Arm tendon lengthening	90	\$822		
24310		Revision of arm tendon	90	\$726		
24320		Repair of arm tendon	90	\$1,451		
24330		Revision of arm muscles	90	\$1,370		
24331		Revision of arm muscles	90	\$1,508		
24340		Repair of biceps tendon	90	\$1,128		
24341		Repair arm tendon/muscle	90	\$1,126		
24342		Repair of ruptured tendon	90	\$1,571		
24343		Repr elbow lat ligmnt w/tiss		\$1,466		
24344		Reconstruct elbow lat ligmnt		\$2,293		
24345		Repr elbw med ligmnt w/tissu		\$1,458		
24346		Reconstruct elbow med ligmnt		\$2,278		
24358		Repair elbow w/deb open		\$1,087		
24359		Repair elbow deb/atch open		\$1,374		
24360		Reconstruct elbow joint	90	\$1,923		
24361		Reconstruct elbow joint	90	\$2,027		
24362		Reconstruct elbow joint	90	\$2,007		
24363		Replace elbow joint...	90	\$2,897		
24365		Reconstruct head of radius	90	\$1,178		
24366		Reconstruct head of radius	90	\$1,524		
24400		Revision of humerus	90	\$1,441		
24410		Revision of humerus	90	\$2,151		
24420		Revision of humerus	90	\$1,926		
24430		Repair of humerus	90	\$2,072		
24435		Repair humerus with graft	90	\$2,220		
24470		Revision of elbow joint	90	\$1,226		
24495		Decompression of forearm	90	\$1,022		
24498		Reinforce humerus....	90	\$1,696		
24500		Treat humerus fracture	90	\$418		
24505		Treat humerus fracture	90	\$711		
24515		Repair humerus fracture	90	\$1,566		
24516		Repair humerus fracture	90	\$1,566		
24530		Treat humerus fracture	90	\$457		
24535		Treat humerus fracture	90	\$859		
24538		Treat humerus fracture	90	\$1,281		
24545		Repair humerus fracture	90	\$1,502		
24546		Repair humerus fracture	90	\$1,856		
24560		Treat humerus fracture	90	\$360		
24565		Treat humerus fracture	90	\$653		
24566		Treat humerus fracture	90	\$1,005		
24575		Repair humerus fracture	90	\$1,341		
24576		Treat humerus fracture	90	\$364		
24577		Treat humerus fracture	90	\$712		
24579		Repair humerus fracture	90	\$1,456		
24582		Treat humerus fracture	90	\$1,098		
24586		Repair elbow fracture	90	\$2,226		
24587		Repair elbow fracture	90	\$2,134		
24600		Treat elbow dislocation	90	\$446		
24605		Treat elbow dislocation	90	\$549		
24615		Repair elbow dislocation	90	\$1,383		
24620		Treat elbow fracture	90	\$777		
24635		Repair elbow fracture	90	\$1,788		
24640		Treat elbow dislocation	10	\$159		
24650		Treat radius fracture	90	\$325		
24655		Treat radius fracture	90	\$541		
24665		Repair radius fracture	90	\$1,130		
24666		Repair radius fracture	90	\$1,468		
24670		Treatment of ulna fracture	90	\$327		
24675		Treatment of ulna fracture	90	\$607		
24685		Repair ulna fracture	90	\$1,279		
24800		Fusion of elbow joint	90	\$1,614		
24802		Fusion/graft of elbow joint	90	\$1,922		
24900		Amputation of upper arm	90	\$1,263		

LABOR AND EMPLOYMENT

CPT Code	Mod	Description	Global Days	Maximum Allowance	Non-Facility Maximum	Facility Maximum
24920		Amputation of upper arm	90	\$1,180		
24925		Amputation follow-up surgery	90	\$965		
24930		Amputation follow-up surgery	90	\$1,326		
24931		Amputate upper arm & implant	90	\$1,750		
24935		Revision of amputation	90	\$2,145		
24940		Revision of upper arm	90	BR		
24999		Upper arm/elbow surgery		BR		
25000		Incision of tendon sheath	90	\$586		
25001		Incise flexor carpi radialis		\$714		
25020		Decompression of forearm	90	\$756		
25023		Decompression of forearm	90	\$1,287		
25024		Decompress forearm 2 spaces		\$1,632		
25025		Decompress forearm 2 spaces		\$2,544		
25028		Drainage of forearm lesion	90	\$516		
25031		Drainage of forearm bursa	90	\$463		
25035		Treat forearm bone lesion	90	\$1,156		
25040		Explore/treat wrist joint	90	\$1,013		
25065		Biopsy forearm soft tissues	10	\$229		
25066		Biopsy forearm soft tissues	90	\$507		
25071		Exc forearm les sc 3 cm/>		\$885		
25073		Exc forearm tum deep 3 cm/>		\$1,106		
25075		Removal of forearm lesion	90	\$437		
25076		Removal of forearm lesion	90	\$652		
25077		Remove tumor, forearm/wrist	90	\$1,373		
25078		Resect forearm/wrist tum 3cm>		\$2,437		
25085		Incision of wrist capsule	90	\$848		
25100		Biopsy of wrist joint	90	\$666		
25101		Explore/treat wrist joint	90	\$780		
25105		Remove wrist joint lining	90	\$990		
25107		Remove wrist joint cartilage	90	\$957		
25109		Excise tendon forearm/wrist	90	\$1,117		
25110		Remove wrist tendon lesion	90	\$500		
25111		Remove wrist tendon lesion	90	\$497		
25112		Reremove wrist tendon lesion	90	\$621		
25115		Remove wrist/forearm lesion	90	\$1,036		
25116		Remove wrist/forearm lesion	90	\$1,132		
25118		Excise wrist tendon sheath	90	\$762		
25119		Partial removal of ulna	90	\$1,015		
25120		Removal of forearm lesion	90	\$946		
25125		Remove/graft forearm lesion	90	\$1,058		
25126		Remove/graft forearm lesion	90	\$1,066		
25130		Removal of wrist lesion	90	\$706		
25135		Remove & graft wrist lesion	90	\$921		
25136		Remove & graft wrist lesion	90	\$798		
25145		Remove forearm bone lesion	90	\$898		
25150		Partial removal of ulna	90	\$1,015		
25151		Partial removal of radius	90	\$965		
25170		Extensive forearm surgery	90	\$1,540		
25210		Removal of wrist bone	90	\$795		
25215		Removal of wrist bones	90	\$1,239		
25230		Partial removal of radius	90	\$798		
25240		Partial removal of ulna	90	\$862		
25246		Injection for wrist X-ray	0	\$143		
25248		Remove forearm foreign body	90	\$646		
25250		Removal of wrist prosthesis	90	\$910		
25251		Removal of wrist prosthesis	90	\$1,326		
25259		Manipulate wrist w/anesthes		\$859		
25260		Repair forearm tendon/muscle	90	\$901		
25263		Repair forearm tendon/muscle	90	\$1,003		
25265		Repair forearm tendon/muscle	90	\$1,337		
25270		Repair forearm tendon/muscle	90	\$682		
25272		Repair forearm tendon/muscle	90	\$761		
25274		Repair forearm tendon/muscle	90	\$1,146		
25275		Repair forearm tendon sheath		\$1,412		
25280		Revise wrist/forearm tendon	90	\$831		
25290		Incise wrist/forearm tendon	90	\$560		

Title 40, Part I

CPT Code	Mod	Description	Global Days	Maximum Allowance	Non-Facility Maximum	Facility Maximum
25295		Release wrist/forearm tendon	90	\$696		
25300		Fusion of tendons at wrist	90	\$1,204		
25301		Fusion of tendons at wrist	90	\$1,136		
25310		Transplant forearm tendon	90	\$1,132		
25312		Transplant forearm tendon	90	\$1,275		
25315		Revise palsy hand tendon(s)	90	\$1,498		
25316		Revise palsy hand tendon(s)	90	\$1,661		
25320		Repair/revise wrist joint	90	\$1,500		
25332		Revise wrist joint....	90	\$1,636		
25335		Realignment of hand	90	\$1,776		
25337		Reconstruct ulna/radioulnar	90	\$1,341		
25350		Revision of radius	90	\$1,210		
25355		Revision of radius	90	\$1,428		
25360		Revision of ulna	90	\$1,082		
25365		Revise radius & ulna	90	\$1,664		
25370		Revise radius or ulna	90	\$1,842		
25375		Revise radius & ulna	90	\$1,878		
25390		Shorten radius/ulna	90	\$1,428		
25391		Lengthen radius/ulna	90	\$1,836		
25392		Shorten radius & ulna	90	\$1,949		
25393		Lengthen radius & ulna	90	\$2,226		
25394		Repair carpal bone shorten		\$1,623		
25400		Repair radius or ulna	90	\$1,616		
25405		Repair/graft radius or ulna	90	\$1,977		
25415		Repair radius & ulna	90	\$1,839		
25420		Repair/graft radius & ulna	90	\$2,288		
25425		Repair/graft radius or ulna	90	\$1,864		
25426		Repair/graft radius & ulna	90	\$2,037		
25430		Vasc graft into carpal bone		\$1,468		
25431		Repair nonunion carpal bone		\$1,634		
25440		Repair/graft wrist bone	90	\$1,452		
25441		Reconstruct wrist joint	90	\$1,806		
25442		Reconstruct wrist joint	90	\$1,318		
25443		Reconstruct wrist joint	90	\$1,471		
25444		Reconstruct wrist joint	90	\$1,589		
25445		Reconstruct wrist joint	90	\$1,512		
25446		Wrist replacement	90	\$2,751		
25447		Repair wrist joint(s)	90	\$1,534		
25449		Remove wrist joint implant	90	\$1,613		
25450		Revision of wrist joint	90	\$1,145		
25455		Revision of wrist joint	90	\$1,365		
25490		Reinforce radius	90	\$1,362		
25491		Reinforce ulna	90	\$1,426		
25492		Reinforce radius and ulna	90	\$1,755		
25500		Treat fracture of radius	90	\$349		
25505		Treat fracture of radius	90	\$641		
25515		Repair fracture of radius	90	\$1,237		
25520		Repair fracture of radius	90	\$899		
25525		Repair fracture of radius	90	\$1,746		
25526		Repair fracture of radius	90	\$1,856		
25530		Treat fracture of ulna	90	\$335		
25535		Treat fracture of ulna	90	\$639		
25545		Repair fracture of ulna	90	\$1,212		
25560		Treat fracture radius & ulna	90	\$343		
25565		Treat fracture radius & ulna	90	\$754		
25574		Treat fracture radius & ulna	90	\$1,225		
25575		Repair fracture radius/ulna	90	\$1,551		
25600		Treat fracture radius/ulna	90	\$406		
25605		Treat fracture radius/ulna	90	\$703		
25606		Treat fx distal radial		\$1,372		
25607		Treat fx rad extra-articul		\$1,528		
25608		Treat fx rad intra-articul		\$1,712		
25609		Treat fx radial 3+ frag		\$2,179		
25622		Treat wrist bone fracture	90	\$357		
25624		Treat wrist bone fracture	90	\$604		
25628		Repair wrist bone fracture	90	\$1,140		

LABOR AND EMPLOYMENT

CPT Code	Mod	Description	Global Days	Maximum Allowance	Non-Facility Maximum	Facility Maximum
25630		Treat wrist bone fracture	90	\$369		
25635		Treat wrist bone fracture	90	\$569		
25645		Repair wrist bone fracture	90	\$1,025		
25650		Repair wrist bone fracture	90	\$417		
25651		Pin ulnar styloid fracture		\$1,011		
25652		Treat fracture ulnar styloid		\$1,293		
25660		Treat wrist dislocation	90	\$468		
25670		Repair wrist dislocation	90	\$1,113		
25671		Pin radioulnar dislocation		\$1,098		
25675		Treat wrist dislocation	90	\$500		
25676		Repair wrist dislocation	90	\$1,131		
25680		Treat wrist fracture	90	\$597		
25685		Repair wrist fracture	90	\$1,378		
25690		Treat wrist dislocation	90	\$763		
25695		Repair wrist dislocation	90	\$1,144		
25800		Fusion of wrist joint.	90	\$1,559		
25805		Fusion/graft of wrist joint	90	\$1,806		
25810		Fusion/graft of wrist joint	90	\$1,726		
25820		Fusion of hand bones..	90	\$1,219		
25825		Fusion hand bones with graft	90	\$1,545		
25830		Fusion, radioulnar jnt ulna	90	\$1,520		
25900		Amputation of forearm	90	\$1,171		
25905		Amputation of forearm	90	\$1,179		
25907		Amputation follow-up surgery	90	\$992		
25909		Amputation follow-up	90	\$1,060		
25915		Amputation of forearm	90	\$2,085		
25920		Amputate hand at wrist	90	\$1,153		
25922		Amputate hand at wrist	90	\$958		
25924		Amputation follow-up surgery	90	\$1,174		
25927		Amputation of hand	90	\$1,117		
25929		Amputation follow-up surgery	90	\$908		
25931		Amputation follow-up surgery	90	\$906		
25999		Forearm or wrist surgery		BR		
26010		Drainage of finger abscess	10	\$144		
26011		Drainage of finger abscess	10	\$278		
26020		Drain hand tendon sheath	90	\$753		
26025		Drainage of palm bursa	90	\$809		
26030		Drainage of palm bursa(s)	90	\$984		
26034		Treat hand bone lesion	90	\$924		
26035		Decompress fingers/hand	90	\$1,020		
26037		Decompress fingers/hand	90	\$998		
26040		Release palm contracture	90	\$583		
26045		Release palm contracture	90	\$773		
26055		Incise finger tendon sheath	90	\$509		
26060		Incision of finger tendon	90	\$381		
26070		Explore/treat hand joint	90	\$589		
26075		Explore/treat finger joint	90	\$680		
26080		Explore/treat finger joint	90	\$526		
26100		Biopsy hand joint lining	90	\$563		
26105		Biopsy finger joint lining	90	\$704		
26110		Biopsy finger joint lining	90	\$484		
26111		Exc hand les sc 1.5 cm/>		\$871		
26113		Exc hand tum deep 1.5 cm/>		\$1,142		
26115		Removal of hand lesion	90	\$427		
26116		Removal of hand lesion	90	\$675		
26117		Remove tumor, hand/finger	90	\$1,007		
26118		Exc hand tum ra 3 cm/>		\$2,213		
26121		Release palm contracture	90	\$1,298		
26123		Release palm contracture	90	\$1,478		
26125		Release palm contracture		\$543		
26130		Remove wrist joint lining	90	\$780		
26135		Revise finger joint, each	90	\$874		
26140		Revise finger joint, each	90	\$782		
26145		Tendon excision, palm/finger	90	\$970		
26160		Remove tendon sheath lesion	90	\$405		
26170		Removal of palm tendon, each	90	\$559		

Title 40, Part I

CPT Code	Mod	Description	Global Days	Maximum Allowance	Non-Facility Maximum	Facility Maximum
26180		Removal of finger tendon	90	\$754		
26185		Remove finger bone....	90	\$751		
26200		Remove hand bone lesion	90	\$740		
26205		Remove/graft bone lesion	90	\$1,039		
26210		Removal of finger lesion	90	\$674		
26215		Remove/graft finger lesion	90	\$942		
26230		Partial removal of hand bone	90	\$900		
26235		Partial removal, finger bone	90	\$758		
26236		Partial removal, finger bone	90	\$671		
26250		Extensive hand surgery	90	\$1,125		
26260		Extensive finger surgery	90	\$1,094		
26262		Partial removal of finger	90	\$895		
26320		Removal of implant from hand	90	\$556		
26340		Manipulate finger w/anesth		\$694		
26341		Manipulat palm cord post inj		\$203		
26350		Repair finger/hand tendon	90	\$1,050		
26352		Repair/graft hand tendon	90	\$1,059		
26356		Repair finger/hand tendon	90	\$1,319		
26357		Repair finger/hand tendon	90	\$1,127		
26358		Repair/graft hand tendon	90	\$1,229		
26370		Repair finger/hand tendon	90	\$1,212		
26372		Repair/graft hand tendon	90	\$1,330		
26373		Repair finger/hand tendon	90	\$1,330		
26390		Revise hand/finger tendon	90	\$1,394		
26392		Repair/graft hand tendon	90	\$1,570		
26410		Repair hand tendon....	90	\$746		
26412		Repair/graft hand tendon	90	\$913		
26415		Excision, hand/finger tendon	90	\$1,219		
26416		Graft hand or finger tendon	90	\$1,469		
26418		Repair finger tendon..	90	\$734		
26420		Repair/graft finger tendon	90	\$921		
26426		Repair finger/hand tendon	90	\$1,068		
26428		Repair/graft finger tendon	90	\$1,109		
26432		Repair finger tendon..	90	\$661		
26433		Repair finger tendon..	90	\$761		
26434		Repair/graft finger tendon	90	\$821		
26437		Realignment of tendons	90	\$864		
26440		Release palm/finger tendon	90	\$821		
26442		Release palm & finger tendon	90	\$713		
26445		Release hand/finger tendon	90	\$748		
26449		Release forearm/hand tendon	90	\$1,125		
26450		Incision of palm tendon	90	\$525		
26455		Incision of finger tendon	90	\$496		
26460		Incise hand/finger tendon	90	\$469		
26471		Fusion of finger tendons	90	\$857		
26474		Fusion of finger tendons	90	\$865		
26476		Tendon lengthening....	90	\$738		
26477		Tendon shortening.....	90	\$806		
26478		Lengthening of hand tendon	90	\$883		
26479		Shortening of hand tendon	90	\$941		
26480		Transplant hand tendon	90	\$1,157		
26483		Transplant/graft hand tendon	90	\$1,258		
26485		Transplant palm tendon	90	\$1,249		
26489		Transplant/graft palm tendon	90	\$915		
26490		Revise thumb tendon...	90	\$1,315		
26492		Tendon transfer with graft	90	\$1,479		
26494		Hand tendon/muscle tansfer	90	\$1,172		
26496		Revise thumb tendon	90	\$1,376		
26497		Finger tendon transfer	90	\$1,459		
26498		Finger tendon transfer	90	\$1,937		
26499		Revision of finger	90	\$1,244		
26500		Hand tendon reconstruction	90	\$846		
26502		Hand tendon reconstruction	90	\$917		
26508		Release thumb contracture	90	\$885		
26510		Thumb tendon transfer	90	\$699		
26516		Fusion of knuckle joint	90	\$974		

LABOR AND EMPLOYMENT

CPT Code	Mod	Description	Global Days	Maximum Allowance	Non-Facility Maximum	Facility Maximum
26517		Fusion of knuckle joints	90	\$1,178		
26518		Fusion of knuckle joints	90	\$1,151		
26520		Release knuckle contracture	90	\$900		
26525		Release finger contracture	90	\$852		
26530		Revise knuckle joint..	90	\$1,057		
26531		Revise knuckle with implant	90	\$1,271		
26535		Revise finger joint...	90	\$811		
26536		Revise/implant finger joint	90	\$1,148		
26540		Repair hand joint.....	90	\$1,086		
26541		Repair hand joint with graft	90	\$1,416		
26542		Repair hand joint with graft	90	\$922		
26545		Reconstruct finger joint	90	\$900		
26546		Repair nonunion hand..	90	\$1,388		
26548		Reconstruct finger joint	90	\$1,019		
26550		Construct thumb replacement	90	\$3,377		
26551		Great toe-hand transfer	90	\$6,628		
26553		Single transfer, toe- hand	90	\$6,438		
26554		Double transfer, toe- hand	90	\$7,744		
26555		Positional change of finger	90	\$2,481		
26556		Toe joint transfer....	90	\$6,561		
26560		Repair of web finger	90	\$747		
26561		Repair of web finger	90	\$1,484		
26562		Repair of web finger	90	\$1,488		
26565		Correct metacarpal flaw	90	\$1,057		
26567		Correct finger deformity	90	\$955		
26568		Lengthen metacarpal/finger	90	\$1,405		
26580		Repair hand deformity	90	\$3,197		
26587		Reconstruct extra finger	90	\$1,895		
26590		Repair finger deformity	90	\$2,635		
26591		Repair muscles of hand	90	\$558		
26593		Release muscles of hand	90	\$825		
26596		Excision constricting tissue	90	\$1,291		
26597		Release of scar contracture	90	\$1,328		
26600		Treat metacarpal fracture	90	\$253		
26605		Treat metacarpal fracture	90	\$377		
26607		Treat metacarpal fracture	90	\$655		
26608		Treat metacarpal fracture	90	\$655		
26615		Repair metacarpal fracture	90	\$768		
26641		Treat thumb dislocation	90	\$353		
26645		Treat thumb fracture	90	\$479		
26650		Repair thumb fracture	90	\$718		
26665		Repair thumb fracture	90	\$1,035		
26670		Treat hand dislocation	90	\$326		
26675		Treat hand dislocation	90	\$665		
26676		Pin hand dislocation	90	\$766		
26685		Repair hand dislocation	90	\$935		
26686		Repair hand dislocation	90	\$1,050		
26700		Treat knuckle dislocation	90	\$320		
26705		Treat knuckle dislocation	90	\$427		
26706		Pin knuckle dislocation	90	\$733		
26715		Repair knuckle dislocation	90	\$728		
26720		Treat finger fracture, each	90	\$199		
26725		Treat finger fracture, each	90	\$351		
26727		Treat finger fracture, each	90	\$549		
26735		Repair finger fracture, each	90	\$712		
26740		Treat finger fracture, each	90	\$222		
26742		Treat finger fracture, each	90	\$425		
26746		Repair finger fracture, each	90	\$786		
26750		Treat finger fracture, each	90	\$180		
26755		Treat finger fracture, each	90	\$297		
26756		Pin finger fracture, each	90	\$455		
26765		Repair finger fracture, each	90	\$506		
26770		Treat finger dislocation	90	\$264		
26775		Treat finger dislocation	90	\$341		
26776		Pin finger dislocation	90	\$497		
26785		Repair finger dislocation	90	\$534		

Title 40, Part I

CPT Code	Mod	Description	Global Days	Maximum Allowance	Non-Facility Maximum	Facility Maximum
26820		Thumb fusion with graft	90	\$1,100		
26841		Fusion of thumb	90	\$989		
26842		Thumb fusion with graft	90	\$1,254		
26843		Fusion of hand joint	90	\$1,039		
26844		Fusion/graft of hand joint	90	\$1,188		
26850		Fusion of knuckle	90	\$847		
26852		Fusion of knuckle with graft	90	\$1,040		
26860		Fusion of finger joint	90	\$671		
26861		Fusion of finger jnt, add-on		\$275		
26862		Fusion/graft of finger joint	90	\$926		
26863		Fuse/graft added joint		\$538		
26910		Amputate metacarpal bone	90	\$940		
26951		Amputation of finger/thumb	90	\$551		
26952		Amputation of finger/thumb	90	\$759		
26989		Hand/finger surgery		BR		
26990		Drainage of pelvis lesion	90	\$735		
26991		Drainage of pelvis bursa	90	\$577		
26992		Drainage of bone lesion	90	\$1,633		
27000		Incision of hip tendon	90	\$618		
27001		Incision of hip tendon	90	\$760		
27003		Incision of hip tendon	90	\$1,018		
27005		Incision of hip tendon	90	\$1,055		
27006		Incision of hip tendons	90	\$1,138		
27025		Incision of hip/thigh fascia	90	\$1,225		
27027		Buttock fasciotomy		\$1,765		
27030		Drainage of hip joint	90	\$1,851		
27033		Exploration of hip joint	90	\$1,882		
27035		Denervation of hip joint	90	\$2,197		
27036		Excision of hip joint/muscle	90	\$1,851		
27040		Biopsy of soft tissues	10	\$290		
27041		Biopsy of soft tissues	90	\$988		
27043		Exc hip pelvis les sc 3 cm/>		\$976		
27045		Exc hip/pelv tum deep 5 cm/>		\$1,555		
27047		Remove hip/pelvis lesion	90	\$765		
27048		Remove hip/pelvis lesion	90	\$768		
27049		Remove tumor, hip/pelvis	90	\$1,819		
27050		Biopsy of sacroiliac joint	90	\$723		
27052		Biopsy of hip joint	90	\$1,132		
27054		Removal of hip joint lining	90	\$1,415		
27057		Buttock fasciotomy w/dbrdmt		\$1,980		
27059		Resect hip/pelv tum 5 cm/>		\$3,735		
27060		Removal of ischial bursa	90	\$661		
27062		Remove femur lesion/bursa	90	\$685		
27065		Removal of hip bone lesion	90	\$812		
27066		Removal of hip bone lesion	90	\$1,300		
27067		Remove/graft hip bone lesion	90	\$1,855		
27070		Partial removal of hip bone	90	\$1,519		
27071		Partial removal of hip bone	90	\$1,654		
27075		Extensive hip surgery	90	\$2,340		
27076		Extensive hip surgery	90	\$2,613		
27077		Extensive hip surgery	90	\$3,080		
27078		Extensive hip surgery	90	\$1,609		
27080		Removal of tail bone	90	\$798		
27086		Remove hip foreign body	10	\$175		
27087		Remove hip foreign body	90	\$968		
27090		Removal of hip prosthesis	90	\$1,596		
27091		Removal of hip prosthesis	90	\$3,108		
27093		Injection for hip X-ray	0	\$158		
27095		Injection for hip X-ray	0	\$182		
27096		Inject sacroiliac joint	0	BR		
27097		Revision of hip tendon	90	\$1,263		
27098		Transfer tendon to pelvis	90	\$1,268		
27100		Transfer of abdominal muscle	90	\$1,393		
27105		Transfer of spinal muscle	90	\$1,312		
27110		Transfer of iliopsoas muscle	90	\$1,767		
27111		Transfer of iliopsoas muscle	90	\$1,750		

LABOR AND EMPLOYMENT

CPT Code	Mod	Description	Global Days	Maximum Allowance	Non-Facility Maximum	Facility Maximum
27120		Reconstruction of hip socket	90	\$2,653		
27122		Reconstruction of hip socket	90	\$2,366		
27125		Partial hip replacement	90	\$2,324		
27130		Total hip replacement	90	\$3,500		
27132		Total hip replacement	90	\$3,936		
27134		Revise hip joint replacement	90	\$4,573		
27137		Revise hip joint replacement	90	\$3,583		
27138		Revise hip joint replacement	90	\$3,524		
27140		Transplant of femur ridge	90	\$1,713		
27146		Incision of hip bone	90	\$1,837		
27147		Revision of hip bone	90	\$2,642		
27151		Incision of hip bones	90	\$2,775		
27156		Revision of hip bones	90	\$2,941		
27158		Revision of pelvis....	90	\$2,620		
27161		Incision of neck of femur	90	\$2,253		
27165		Incision/fixation of femur	90	\$2,520		
27170		Repair/graft femur head/neck	90	\$2,404		
27175		Treat slipped epiphysis	90	\$609		
27176		Treat slipped epiphysis	90	\$1,627		
27177		Repair slipped epiphysis	90	\$1,996		
27178		Repair slipped epiphysis	90	\$1,613		
27179		Revise head/neck of femur	90	\$1,746		
27181		Repair slipped epiphysis	90	\$2,060		
27185		Revision of femur epiphysis	90	\$845		
27187		Reinforce hip bones	90	\$2,229		
27193		Treat pelvic ring fracture	90	\$527		
27194		Treat pelvic ring fracture	90	\$930		
27200		Treat tail bone fracture	90	\$243		
27202		Repair tail bone fracture	90	\$960		
27215		Pelvic fracture(s) treatment	90	\$1,768		
27216		Treat pelvic ring fracture	90	\$1,357		
27217		Treat pelvic ring fracture	90	\$2,129		
27218		Treat pelvic ring fracture	90	\$2,528		
27220		Treat hip socket fracture	90	\$720		
27222		Treat hip socket fracture	90	\$1,299		
27226		Treat hip wall fracture	90	\$2,282		
27227		Treat hip fracture(s)	90	\$2,711		
27228		Treat hip fracture(s)	90	\$2,906		
27230		Treat fracture of thigh	90	\$613		
27232		Treat fracture of thigh	90	\$1,399		
27235		Repair of thigh fracture	90	\$2,024		
27236		Repair of thigh fracture	90	\$2,390		
27238		Treatment of thigh fracture	90	\$756		
27240		Treatment of thigh fracture	90	\$1,564		
27244		Repair of thigh fracture	90	\$2,355		
27245		Repair of thigh fracture	90	\$2,665		
27246		Treatment of thigh fracture	90	\$626		
27248		Repair of thigh fracture	90	\$1,720		
27250		Treat hip dislocation	90	\$705		
27252		Treat hip dislocation	90	\$1,027		
27253		Repair of hip dislocation	90	\$1,928		
27254		Repair of hip dislocation	90	\$2,338		
27256		Treatment of hip dislocation	10	\$418		
27257		Treatment of hip dislocation	10	\$720		
27258		Repair of hip dislocation	90	\$2,150		
27259		Repair of hip dislocation	90	\$2,693		
27265		Treatment of hip dislocation	90	\$679		
27266		Treatment of hip dislocation	90	\$913		
27267		Cltx thigh fx		\$906		
27268		Cltx thigh fx w/mnpj		\$1,115		
27269		Optx thigh fx		\$2,585		
27275		Manipulation of hip joint	10	\$296		
27280		Fusion of sacroiliac joint	90	\$1,673		
27282		Fusion of pubic bones	90	\$1,506		
27284		Fusion of hip joint...	90	\$2,372		
27286		Fusion of hip joint	90	\$2,344		



Title 40, Part I

CPT Code	Mod	Description	Global Days	Maximum Allowance	Non-Facility Maximum	Facility Maximum
27290		Amputation of leg at hip	90	\$3,665		
27295		Amputation of leg at hip	90	\$2,605		
27299		Pelvis/hip joint surgery		BR		
27301		Drain thigh/knee lesion	90	\$793		
27303		Drainage of bone lesion	90	\$1,171		
27305		Incise thigh tendon & fascia	90	\$701		
27306		Incision of thigh tendon	90	\$555		
27307		Incision of thigh tendons	90	\$715		
27310		Exploration of knee joint	90	\$1,434		
27323		Biopsy thigh soft tissues	10	\$263		
27324		Biopsy, thigh soft tissues.	90	\$608		
27325		Neurectomy hamstring		\$1,050		
27326		Neurectomy popliteal		\$1,063		
27327		Removal of thigh lesion	90	\$497		
27328		Removal of thigh lesion	90	\$717		
27329		Remove tumor, thigh/knee	90	\$1,810		
27330		Biopsy, knee joint lining	90	\$819		
27331		Explore/treat knee joint	90	\$975		
27332		Removal of knee cartilage	90	\$1,320		
27333		Removal of knee cartilage	90	\$1,613		
27334		Remove knee joint lining	90	\$1,397		
27335		Remove knee joint lining	90	\$1,634		
27337		Exc thigh/knee les sc 3 cm/>		\$872		
27339		Exc thigh/knee tum dep 5cm/>		\$1,556		
27340		Removal of kneecap bursa	90	\$594		
27345		Removal of knee cyst..	90	\$896		
27347		Remove knee cyst.....	90	\$630		
27350		Removal of kneecap	90	\$1,307		
27355		Remove femur lesion	90	\$1,123		
27356		Remove femur lesion/graft	90	\$1,284		
27357		Remove femur lesion/graft	90	\$1,407		
27358		Remove femur lesion/fixation		\$678		
27360		Partial removal, leg bone(s)	90	\$1,583		
27364		Resect thigh/knee tum 5 cm/>		\$3,238		
27365		Extensive leg surgery	90	\$2,285		
27370		Injection for knee X-ray	0	\$115		
27372		Removal of foreign body	90	\$621		
27380		Repair of kneecap tendon	90	\$1,123		
27381		Repair/graft kneecap tendon	90	\$1,611		
27385		Repair of thigh muscle tendon	90	\$1,235		
27386		Repair/graft of thigh muscle	90	\$1,712		
27390		Incision of thigh tendon	90	\$770		
27391		Incision of thigh tendons	90	\$989		
27392		Incision of thigh tendons	90	\$1,308		
27393		Lengthening of thigh tendon	90	\$947		
27394		Lengthening of thigh	90	\$1,124		
27395		Lengthening of thigh tendon	90	\$1,701		
27396		Transplant of thigh tendon	90	\$1,160		
27397		Transplants of thigh tendon	90	\$1,548		
27400		Revise thigh muscles/tendon	90	\$1,293		
27403		Repair of knee cartilage	90	\$1,294		
27405		Repair of knee ligament	90	\$1,403		
27407		Repair of knee ligament	90	\$1,398		
27409		Repair of knee ligaments	90	\$2,080		
27412		Autochondrocyte implant knee		\$3,438		
27415		Osteochondral knee allograft		\$2,854		
27416		Osteochondral knee autograft		\$2,034		
27418		Repair degenerated kneecap	90	\$1,708		
27420		Revision of unstable kneecap	90	\$1,549		
27422		Revision of unstable kneecap	90	\$1,547		
27424		Revision/removal of kneecap	90	\$1,607		
27425		Lateral retinacular release	90	\$891		
27427		Reconstruction, knee	90	\$1,676		
27428		Reconstruction, knee	90	\$2,014		
27429		Reconstruction, knee	90	\$1,767		
27430		Revision of thigh muscles	90	\$1,437		

LABOR AND EMPLOYMENT

CPT Code	Mod	Description	Global Days	Maximum Allowance	Non-Facility Maximum	Facility Maximum
27435		Incision of knee joint	90	\$1,269		
27437		Revise kneecap	90	\$1,360		
27438		Revise kneecap with implant	90	\$1,809		
27440		Revision of knee joint	90	\$1,658		
27441		Revision of knee joint	90	\$1,449		
27442		Revision of knee joint	90	\$1,924		
27443		Revision of knee joint	90	\$2,219		
27445		Revision of knee joint	90	\$2,810		
27446		Revision of knee joint	90	\$2,907		
27447		Total knee replacement	90	\$3,735		
27448		Incision of thigh	90	\$1,784		
27450		Incision of thigh	90	\$2,144		
27454		Realignment of thigh bone	90	\$2,521		
27455		Realignment of knee	90	\$1,838		
27457		Realignment of knee	90	\$1,985		
27465		Shortening of thigh bone	90	\$1,917		
27466		Lengthening of thigh bone	90	\$2,180		
27468		Shorten/lengthen thighs	90	\$2,637		
27470		Repair of thigh	90	\$2,413		
27472		Repair/graft of thigh	90	\$2,791		
27475		Surgery to stop leg growth	90	\$1,244		
27477		Surgery to stop leg growth	90	\$1,879		
27479		Surgery to stop leg growth	90	\$1,820		
27485		Surgery to stop leg growth	90	\$1,286		
27486		Revise knee joint replace	90	\$3,198		
27487		Revise/replace knee joint	90	\$3,983		
27488		Removal of knee prosthesis	90	\$2,382		
27495		Reinforce thigh	90	\$2,457		
27496		Decompression of thigh/knee	90	\$710		
27497		Decompression of thigh/knee	90	\$868		
27498		Decompression of thigh/knee	90	\$990		
27499		Decompression of thigh/knee	90	\$1,140		
27500		Treatment of thigh fracture	90	\$816		
27501		Treatment of thigh fracture	90	\$816		
27502		Treatment of thigh fracture	90	\$1,302		
27503		Treatment of thigh fracture	90	\$1,302		
27506		Repair of thigh fracture	90	\$2,443		
27507		Treatment of thigh fracture	90	\$2,225		
27508		Treatment of thigh fracture	90	\$714		
27509		Treatment of thigh fracture	90	\$825		
27510		Treatment of thigh fracture	90	\$1,140		
27511		Treatment of thigh fracture	90	\$2,199		
27513		Treatment of thigh fracture	90	\$2,504		
27514		Repair of thigh fracture	90	\$2,427		
27516		Repair of thigh growth plate	90	\$740		
27517		Repair of thigh growth plate	90	\$1,225		
27519		Repair of thigh growth plate	90	\$2,021		
27520		Treat kneecap fracture	90	\$437		
27524		Repair of kneecap fracture	90	\$1,513		
27530		Treatment of knee fracture	90	\$507		
27532		Treatment of knee fracture	90	\$949		
27535		Treatment of knee fracture	90	\$1,694		
27536		Repair of knee fracture	90	\$1,988		
27538		Treat knee fracture(s)	90	\$604		
27540		Repair of knee fracture	90	\$1,775		
27550		Treat knee dislocation	90	\$599		
27552		Treat knee dislocation	90	\$804		
27556		Repair of knee dislocation	90	\$1,975		
27557		Repair of knee dislocation	90	\$2,324		
27558		Repair of knee dislocation	90	\$2,392		
27560		Treat kneecap dislocation	90	\$371		
27562		Treat kneecap dislocation	90	\$809		
27566		Repair kneecap dislocation	90	\$1,680		
27570		Fixation of knee joint	10	\$262		
27580		Fusion of knee.....	90	\$2,659		
27590		Amputate leg at thigh	90	\$1,497		

Title 40, Part I

CPT Code	Mod	Description	Global Days	Maximum Allowance	Non-Facility Maximum	Facility Maximum
27591		Amputate leg at thigh	90	\$1,767		
27592		Amputate leg at thigh	90	\$1,308		
27594		Amputation follow-up surgery	90	\$753		
27596		Amputation follow-up surgery	90	\$1,305		
27598		Amputate lower leg at knee	90	\$1,514		
27599		Leg surgery procedure		BR		
27600		Decompression of lower leg	90	\$642		
27601		Decompression of lower leg	90	\$640		
27602		Decompression of lower leg	90	\$810		
27603		Drain lower leg lesion	90	\$510		
27604		Drain lower leg bursa	90	\$382		
27605		Incision of achilles tendon	10	\$438		
27606		Incision of achilles tendon	10	\$448		
27607		Treat lower leg bone lesion	90	\$1,154		
27610		Explore/treat ankle joint	90	\$1,220		
27612		Exploration of ankle joint	90	\$1,157		
27613		Biopsy lower leg soft tissue	10	\$205		
27614		Biopsy lower leg soft tissue	90	\$686		
27615		Remove tumor, lower leg	90	\$1,518		
27616		Resect leg/ankle tum 5 cm/>		\$2,641		
27618		Remove lower leg lesion	90	\$636		
27619		Remove lower leg lesion	90	\$1,023		
27620		Explore, treat ankle joint	90	\$898		
27625		Remove ankle joint lining	90	\$1,285		
27626		Remove ankle joint lining	90	\$1,458		
27630		Removal of tendon lesion	90	\$581		
27632		Exc leg/ankle les sc 3 cm/>		\$868		
27634		Exc leg/ankle tum dep 5 cm/>		\$1,430		
27635		Remove lower leg bone lesion	90	\$1,175		
27637		Remove/graft leg bone lesion	90	\$1,346		
27638		Remove/graft leg bone lesion	90	\$1,456		
27640		Partial removal of tibia	90	\$1,690		
27641		Partial removal of fibula	90	\$1,180		
27645		Extensive lower leg surgery	90	\$2,012		
27646		Extensive lower leg surgery	90	\$1,710		
27647		Extensive ankle/heel surgery	90	\$1,593		
27648		Injection for ankle X-ray	0	\$109		
27650		Repair achilles tendon	90	\$1,378		
27652		Repair/graft achilles tendon	90	\$1,529		
27654		Repair of achilles tendon	90	\$1,560		
27656		Repair leg fascia defect	90	\$570		
27658		Repair of leg tendon, each	90	\$733		
27659		Repair of leg tendon, each	90	\$971		
27664		Repair of leg tendon, each	90	\$722		
27665		Repair of leg tendon, each	90	\$867		
27675		Repair lower leg tendons	90	\$1,000		
27676		Repair lower leg tendons	90	\$1,173		
27680		Release of lower leg tendon	90	\$778		
27681		Release of lower leg tendons	90	\$986		
27685		Revision of lower leg tendons	90	\$811		
27686		Revise lower leg tendons	90	\$1,073		
27687		Revision of calf tendon	90	\$853		
27690		Revise lower leg tendon	90	\$1,113		
27691		Revise lower leg tendon	90	\$1,374		
27692		Revise additional leg tendons		\$283		
27695		Repair of ankle ligament	90	\$1,065		
27696		Repair of ankle ligaments	90	\$1,129		
27698		Repair of ankle ligament	90	\$1,481		
27700		Revision of ankle joint	90	\$1,517		
27702		Reconstruct ankle joint	90	\$2,702		
27703		Reconstruction, ankle joint	90	\$2,193		
27704		Removal of ankle implant	90	\$993		
27705		Incision of tibia	90	\$1,567		
27707		Incision of fibula	90	\$655		
27709		Incision of tibia & fibula	90	\$1,659		
27712		Realignment of lower leg	90	\$1,913		

LABOR AND EMPLOYMENT

CPT Code	Mod	Description	Global Days	Maximum Allowance	Non-Facility Maximum	Facility Maximum
27715		Revision of lower leg	90	\$2,049		
27720		Repair of tibia	90	\$1,924		
27722		Repair/graft of tibia	90	\$1,633		
27724		Repair/graft of tibia	90	\$2,212		
27725		Repair of lower leg	90	\$1,629		
27726		Repair fibula nonunion		\$2,021		
27727		Repair of lower leg	90	\$1,706		
27730		Repair of tibia epiphysis	90	\$1,029		
27732		Repair of fibula epiphysis	90	\$757		
27734		Repair lower leg epiphyses	90	\$1,179		
27740		Repair of leg epiphyses	90	\$1,261		
27742		Repair of leg epiphyses	90	\$1,454		
27745		Reinforce tibia	90	\$1,398		
27750		Treatment of tibia fracture	90	\$486		
27752		Treatment of tibia fracture	90	\$784		
27756		Repair of tibia fracture	90	\$1,199		
27758		Repair of tibia fracture	90	\$1,854		
27759		Repair of tibia fracture	90	\$2,021		
27760		Treatment of ankle fracture	90	\$408		
27762		Treatment of ankle fracture	90	\$614		
27766		Repair of ankle fracture	90	\$1,185		
27767		Cltx post ankle fx		\$589		
27768		Cltx post ankle fx w/mnpj		\$912		
27769		Optx post ankle fx		\$1,529		
27780		Treatment of fibula fracture	90	\$333		
27781		Treatment of fibula fracture	90	\$566		
27784		Repair of fibula fracture	90	\$914		
27786		Treatment of ankle fracture	90	\$394		
27788		Treatment of ankle fracture	90	\$569		
27792		Repair of ankle fracture	90	\$1,104		
27808		Treatment of ankle fracture	90	\$411		
27810		Treatment of ankle fracture	90	\$756		
27814		Repair of ankle fracture	90	\$1,520		
27816		Treatment of ankle fracture	90	\$483		
27818		Treatment of ankle fracture	90	\$896		
27822		Repair of ankle fracture	90	\$1,497		
27823		Repair of ankle fracture	90	\$1,822		
27824		Treat lower leg fracture	90	\$483		
27825		Treat lower leg fracture	90	\$896		
27826		Treat lower leg fracture	90	\$1,412		
27827		Treat lower leg fracture	90	\$1,663		
27828		Treat lower leg fracture	90	\$1,923		
27829		Treat lower leg joint	90	\$985		
27830		Treat lower leg dislocation	90	\$511		
27831		Treat lower leg dislocation	90	\$626		
27832		Repair lower leg dislocation	90	\$889		
27840		Treat ankle dislocation	90	\$450		
27842		Treat ankle dislocation	90	\$586		
27846		Repair ankle dislocation	90	\$1,346		
27848		Repair ankle dislocation	90	\$1,425		
27860		Fixation of ankle joint	10	\$278		
27870		Fusion of ankle joint	90	\$1,839		
27871		Fusion of tibiofibular joint	90	\$1,243		
27880		Amputation of lower leg	90	\$1,462		
27881		Amputation of lower leg	90	\$1,669		
27882		Amputation of lower leg	90	\$1,174		
27884		Amputation follow-up surgery	90	\$806		
27886		Amputation follow-up surgery	90	\$1,193		
27888		Amputation of foot at ankle	90	\$1,461		
27889		Amputation of foot at ankle	90	\$1,331		
27892		Decompression of leg	90	\$713		
27893		Decompression of leg	90	\$712		
27894		Decompression of leg	90	\$882		
27899		Leg/ankle surgery procedure		BR		
28001		Drainage of bursa of foot	10	\$291		
28002		Treatment of foot infection	10	\$553		

Title 40, Part I

CPT Code	Mod	Description	Global Days	Maximum Allowance	Non-Facility Maximum	Facility Maximum
28003		Treatment of foot infection	90	\$820		
28005		Treat foot bone lesion	90	\$1,019		
28008		Incision of foot fascia	90	\$507		
28010		Incision of toe tendon	90	\$506		
28011		Incision of toe tendons	90	\$509		
28020		Exploration of foot joint	90	\$753		
28022		Exploration of a foot joint	90	\$528		
28024		Exploration of a toe joint	90	\$479		
28035		Decompression of tibia nerve	90	\$860		
28039		Exc foot/toe tum sc 1.5 cm/>		\$1,097		
28041		Exc foot/toe tum dep 1.5cm/>		\$980		
28043		Excision of foot lesion	90	\$446		
28045		Excision of foot lesion	90	\$631		
28046		Resection of tumor, foot	90	\$1,101		
28047		Resect foot/toe tumor 3 cm/>		\$2,147		
28050		Biopsy of foot joint lining	90	\$650		
28052		Biopsy of foot joint lining	90	\$563		
28054		Biopsy of toe joint lining	90	\$406		
28055		Neurectomy foot		\$781		
28060		Partial removal, foot fascia	90	\$736		
28062		Removal of foot fascia	90	\$1,002		
28070		Removal of foot joint lining	90	\$686		
28072		Removal of foot joint lining	90	\$563		
28080		Removal of foot lesion	90	\$596		
28086		Excise foot tendon sheath	90	\$574		
28088		Excise foot tendon sheath	90	\$541		
28090		Removal of foot lesion	90	\$591		
28092		Removal of toe lesions	90	\$481		
28100		Removal of ankle/heel lesion	90	\$745		
28102		Remove/graft foot lesion	90	\$1,062		
28103		Remove/graft foot lesion	90	\$878		
28104		Removal of foot lesion	90	\$686		
28106		Remove/graft foot lesion	90	\$988		
28107		Remove/graft foot lesion	90	\$744		
28108		Removal of toe lesions	90	\$608		
28110		Part removal of metatarsal	90	\$544		
28111		Part removal of metatarsal	90	\$732		
28112		Part removal of metatarsal	90	\$612		
28113		Part removal of metatarsal	90	\$639		
28114		Removal of metatarsal heads	90	\$1,450		
28116		Revision of foot	90	\$866		
28118		Removal of heel bone	90	\$845		
28119		Removal of heel spur	90	\$787		
28120		Part removal of ankle/heel	90	\$843		
28122		Partial removal of foot bone	90	\$927		
28124		Partial removal of toe	90	\$699		
28126		Partial removal of toe	90	\$586		
28130		Removal of ankle bone	90	\$1,079		
28140		Removal of metatarsal	90	\$850		
28150		Removal of toe.....	90	\$596		
28153		Partial removal of toe	90	\$595		
28160		Partial removal of toe	90	\$613		
28171		Extensive foot surgery	90	\$1,286		
28173		Extensive foot surgery	90	\$1,038		
28175		Extensive foot surgery	90	\$818		
28190		Removal of foot foreign body	10	\$176		
28192		Removal of foot foreign body	90	\$473		
28193		Removal of foot foreign body	90	\$575		
28200		Repair of foot tendon	90	\$732		
28202		Repair/graft of foot tendon	90	\$918		
28208		Repair of foot tendon	90	\$573		
28210		Repair/graft of foot tendon	90	\$861		
28220		Release of foot tendon	90	\$654		
28222		Release of foot tendons	90	\$891		
28225		Release of foot tendon	90	\$493		
28226		Release of foot tendons	90	\$629		

LABOR AND EMPLOYMENT

CPT Code	Mod	Description	Global Days	Maximum Allowance	Non-Facility Maximum	Facility Maximum
28230		Incision of foot tendon(s)	90	\$540		
28232		Incision of toe tendon	90	\$428		
28234		Incision of foot tendon	90	\$425		
28238		Revision of foot tendon	90	\$1,120		
28240		Release of big toe	90	\$459		
28250		Revision of foot fascia	90	\$798		
28260		Release of midfoot joint	90	\$879		
28261		Revision of foot tendon	90	\$1,092		
28262		Revision of foot and ankle	90	\$2,038		
28264		Release of midfoot joint	90	\$1,469		
28270		Release of foot contracture	90	\$596		
28272		Release of toe joint, each	90	\$479		
28280		Fusion of toes.....	90	\$620		
28285		Repair of hammertoe...	90	\$691		
28286		Repair of hammertoe...	90	\$644		
28288		Partial removal of foot bone	90	\$673		
28289		Repair hallux rigidus	90	\$717		
28290		Correction of bunion..	90	\$849		
28292		Correction of bunion	90	\$994		
28293		Correction of bunion	90	\$1,330		
28294		Correction of bunion..	90	\$1,296		
28296		Correction of bunion	90	\$1,309		
28297		Correction of bunion	90	\$1,328		
28298		Correction of bunion	90	\$1,218		
28299		Correction of bunion	90	\$1,393		
28300		Incision of heel bone.	90	\$1,292		
28302		Incision of ankle bone	90	\$1,355		
28304		Incision of midfoot bones	90	\$1,186		
28305		Incise/graft midfoot bones	90	\$1,617		
28306		Incision of metatarsal	90	\$798		
28307		Incision of metatarsal	90	\$916		
28308		Incision of metatarsal	90	\$814		
28309		Incision of metatarsals	90	\$1,486		
28310		Revision of big toe...	90	\$745		
28312		Revision of toe	90	\$659		
28313		Repair deformity of toe	90	\$625		
28315		Removal of sesamoid bone	90	\$655		
28320		Repair of foot bones..	90	\$1,324		
28322		Repair of metatarsals	90	\$936		
28340		Resect enlarged toe tissue	90	\$979		
28341		Resect enlarged toe	90	\$1,167		
28344		Repair extra toe(s)	90	\$580		
28345		Repair webbed toe(s)	90	\$821		
26590		Repair finger deformity	90	\$2,635		
28400		Treatment of heel fracture	90	\$353		
28405		Treatment of heel fracture	90	\$621		
28406		Treatment of heel fracture	90	\$909		
28415		Repair of heel fracture	90	\$1,678		
28420		Repair/graft heel fracture	90	\$2,005		
28430		Treatment of ankle fracture	90	\$337		
28435		Treatment of ankle fracture	90	\$504		
28436		Treatment of ankle fracture	90	\$657		
28445		Repair of ankle fracture	90	\$1,344		
28446		Osteochondral talus autograft		\$2,544		
28450		Treat midfoot fracture, each	90	\$276		
28455		Treat midfoot fracture, each	90	\$412		
28456		Repair midfoot fracture	90	\$357		
28465		Repair midfoot fracture, each	90	\$913		
28470		Treat metatarsal fracture	90	\$269		
28475		Treat metatarsal fracture	90	\$381		
28476		Repair metatarsal fracture	90	\$494		
28485		Repair metatarsal fracture	90	\$750		
28490		Treat big toe fracture	90	\$143		
28495		Treat big toe fracture	90	\$194		
28496		Repair big toe fracture	90	\$322		
28505		Repair big toe fracture	90	\$493		

Title 40, Part I

CPT Code	Mod	Description	Global Days	Maximum Allowance	Non-Facility Maximum	Facility Maximum
28510		Treatment of toe fracture	90	\$141		
28515		Treatment of toe fracture	90	\$184		
28525		Repair of toe fracture	90	\$384		
28530		Treat sesamoid bone fracture	90	\$150		
28531		Treat sesamoid bone fracture	90	\$300		
28540		Treat foot dislocation	90	\$181		
28545		Treat foot dislocation	90	\$257		
28546		Treat foot dislocation	90	\$430		
28555		Repair foot dislocation	90	\$860		
28570		Treat foot dislocation	90	\$236		
28575		Treat foot dislocation	90	\$432		
28576		Treat foot dislocation	90	\$491		
28585		Repair foot dislocation	90	\$919		
28600		Treat foot dislocation	90	\$179		
28605		Treat foot dislocation	90	\$356		
28606		Treat foot dislocation	90	\$604		
28615		Repair foot dislocation	90	\$770		
28630		Treat toe dislocation	10	\$198		
28635		Treat toe dislocation	10	\$248		
28636		Treat toe dislocation	10	\$400		
28645		Repair toe dislocation	90	\$537		
28660		Treat toe dislocation	10	\$133		
28665		Treat toe dislocation	10	\$210		
28666		Treat toe dislocation	10	\$383		
28675		Repair of toe dislocation	90	\$431		
28705		Fusion of foot bones..	90	\$2,250		
28715		Fusion of foot bones..	90	\$1,912		
28725		Fusion of foot bones..	90	\$1,590		
28730		Fusion of foot bones	90	\$1,433		
28735		Fusion of foot bones..	90	\$1,542		
28737		Revision of foot bones	90	\$1,388		
28740		Fusion of foot bones	90	\$854		
28750		Fusion of big toe joint	90	\$773		
28755		Fusion of big toe joint	90	\$611		
28760		Fusion of big toe joint	90	\$1,006		
28800		Amputation of midfoot	90	\$1,141		
28805		Amputation thru metatarsal	90	\$1,067		
28810		Amputation toe & metatarsal	90	\$721		
28820		Amputation of toe	90	\$468		
28825		Partial amputation of toe	90	\$420		
28890		High energy eswt plantar f			\$696	\$467
28899		Foot/toes surgery procedure		BR		
29000		Application of body cast	0	\$305		
29010		Application of body cast	0	\$335		
29015		Application of body cast	0	\$360		
29020		Application of body cast	0	\$294		
29025		Application of body cast	0	\$234		
29035		Application of body cast	0	\$286		
29040		Application of body cast	0	\$321		
29044		Application of body cast	0	\$322		
29046		Application of body cast	0	\$354		
29049		Application of shoulder cast	0	\$97		
29055		Application of shoulder cast	0	\$223		
29058		Application of shoulder cast	0	\$145		
29065		Application of long arm cast	0	\$128		
29075		Application of forearm cast	0	\$105		
29085		Apply hand/wrist cast	0	\$103		
29086		Apply finger cast			\$163	\$107
29105		Apply long arm splint	0	\$103		
29125		Apply forearm splint	0	\$72		
29126		Apply forearm splint	0	\$87		
29130		Application of finger splint	0	\$49		
29131		Application of finger splint	0	\$71		
29200		Strapping of chest	0	\$68		
29220		Strapping of low back	0	\$76		
29240		Strapping of shoulder	0	\$72		

LABOR AND EMPLOYMENT

CPT Code	Mod	Description	Global Days	Maximum Allowance	Non-Facility Maximum	Facility Maximum
29260		Strapping of elbow or wrist	0	\$58		
29280		Strapping of hand or finger	0	\$53		
29305		Application of hip cast	0	\$299		
29325		Application of hip casts	0	\$322		
29345		Application of long leg cast	0	\$183		
29355		Application of long leg cast	0	\$199		
29358		Apply long leg cast brace	0	\$259		
29365		Application of long leg cast	0	\$154		
29405		Apply short leg cast	0	\$126		
29425		Apply short leg cast	0	\$150		
29435		Apply short leg cast	0	\$180		
29440		Addition of walker to cast	0	\$59		
29445		Apply rigid leg cast	0	\$263		
29450		Application of leg cast	0	\$103		
29505		Application long leg splint	0	\$95		
29515		Application lower leg splint	0	\$90		
29520		Strapping of hip	0	\$66		
29530		Strapping of knee	0	\$69		
29540		Strapping of ankle	0	\$60		
29550		Strapping of toes	0	\$56		
29580		Application of paste boot	0	\$100		
29581		Apply multilayer comprs lwr leg			\$126	\$26
29582		Apply multilayer comprs upr leg			\$143	\$32
29583		Apply multilayer comprs upr arm			\$89	\$23
29584		Apply multilayer comprs arm/hand			\$143	\$32
29590		Application of foot splint	0	\$76		
29700		Removal/revision of cast	0	\$89		
29705		Removal/revision of cast	0	\$108		
29710		Removal/revision of cast	0	\$132		
29715		Removal/revision of cast	0	\$136		
29720		Repair of body cast	0	\$68		
29730		Windowing of cast	0	\$75		
29740		Wedging of cast	0	\$110		
29750		Wedging of clubfoot cast	0	\$130		
29799		Casting/strapping procedure		BR		
29800		Jaw arthroscopy/surgery	90	\$691		
29804		Jaw arthroscopy/surgery	90	\$1,635		
29805		Shoulder arthroscopy dx		\$981		
29806		Shoulder arthroscopy/surgery		\$2,210		
29807		Shoulder arthroscopy/surgery		\$2,152		
29819		Shoulder arthroscopy/surgery	90	\$1,329		
29820		Shoulder arthroscopy/surgery	90	\$1,282		
29821		Shoulder arthroscopy/surgery	90	\$1,515		
29822		Shoulder arthroscopy/surgery	90	\$1,328		
29823		Shoulder arthroscopy/surgery	90	\$1,622		
29824		Shoulder arthroscopy/surgery		\$1,412		
29825		Shoulder arthroscopy/surgery	90	\$1,466		
29826		Shoulder arthroscopy/surgery	90	\$1,687		
29827		Arthroscop rotator cuff repr		\$2,241		
29828		Arthroscopy biceps tenodesis		\$1,926		
29830		Elbow arthroscopy	90	\$834		
29834		Elbow arthroscopy/surgery	90	\$916		
29835		Elbow arthroscopy/surgery	90	\$945		
29836		Elbow arthroscopy/surgery	90	\$1,101		
29837		Elbow arthroscopy/surgery	90	\$1,004		
29838		Elbow arthroscopy/surgery	90	\$1,105		
29840		Wrist arthroscopy	90	\$654		
29843		Wrist arthroscopy/surgery	90	\$876		
29844		Wrist arthroscopy/surgery	90	\$903		
29845		Wrist arthroscopy/surgery	90	\$1,097		
29846		Wrist arthroscopy/surgery	90	\$1,391		
29847		Wrist arthroscopy/surgery	90	\$1,040		
29848		Wrist endoscopy/ surgery	90	\$756		
29850		Knee arthroscopy/surgery	90	\$1,409		
29851		Knee arthroscopy/surgery	90	\$1,775		
29855		Tibial arthroscopy/surgery	90	\$1,632		



Title 40, Part I

CPT Code	Mod	Description	Global Days	Maximum Allowance	Non-Facility Maximum	Facility Maximum
29856		Tibial arthroscopy/surgery	90	\$1,901		
29860		Hip arthroscopy, dx...	90	\$996		
29861		Hip arthroscopy/ surgery	90	\$1,402		
29862		Hip arthroscopy/ surgery	90	\$1,536		
29863		Hip arthroscopy/ surgery	90	\$1,431		
29866		Autgrft implnt knee w/scope		\$2,181		
29867		Allgrft implnt knee w/scope		\$2,657		
29868		Meniscal trnspl knee w/scp		\$3,481		
29870		Knee arthroscopy, diagnostic	90	\$679		
29871		Knee arthroscopy/drainage	90	\$993		
29873		Knee arthroscopy/surgery		\$1,089		
29874		Knee arthroscopy/surgery	90	\$1,229		
29875		Knee arthroscopy/surgery	90	\$1,193		
29876		Knee arthroscopy/surgery	90	\$1,443		
29877		Knee arthroscopy/surgery	90	\$1,348		
29879		Knee arthroscopy/ surgery	90	\$1,315		
29880		Knee arthroscopy/surgery	90	\$1,606		
29881		Knee arthroscopy/surgery	90	\$1,387		
29882		Knee arthroscopy/surgery	90	\$1,488		
29883		Knee arthroscopy/surgery	90	\$1,905		
29884		Knee arthroscopy/surgery	90	\$1,235		
29885		Knee arthroscopy/surgery	90	\$1,289		
29886		Knee arthroscopy/surgery	90	\$1,066		
29887		Knee arthroscopy/surgery	90	\$1,474		
29888		Knee arthroscopy/surgery	90	\$2,463		
29889		Knee arthroscopy/surgery	90	\$1,607		
29891		Ankle arthroscopy/ surgery	90	\$1,323		
29892		Ankle arthroscopy/ surgery	90	\$1,370		
29893		Scope, plantar fasciotomy	90	\$764		
29894		Ankle arthroscopy/surgery	90	\$1,285		
29895		Ankle arthroscopy/surgery	90	\$1,221		
29897		Ankle arthroscopy/surgery	90	\$1,316		
29898		Ankle arthroscopy/surgery	90	\$1,510		
29899		Ankle arthroscopy/surgery		\$2,165		
29900		Mcp joint arthroscopy dx		\$1,000		
29901		Mcp joint arthroscopy surg		\$1,133		
29902		Mcp joint arthroscopy surg		\$1,253		
29904		Subtalar arthro w/fb rmvl		\$1,324		
29905		Subtalar arthro w/exc		\$1,434		
29906		Subtalar arthro w/deb		\$1,509		
29907		Subtalar arthro w/fusion		\$1,820		
29914		Hip arthro w/femoroplasty		\$2,112		
29915		Hip arthro acetabuloplasty		\$2,152		
29916		Hip arthro w/labral repair		\$2,152		
30000		Drainage of nose lesion	10	\$143		
30020		Drainage of nose lesion	10	\$145		
30100		Intranasal biopsy	0	\$122		
30110		Removal of nose polyp(s)	10	\$213		
30115		Removal of nose polyp(s)	90	\$521		
30117		Removal of intranasal lesion	90	\$439		
30118		Removal of intranasal lesion	90	\$1,286		
30120		Revision of nose	90	\$901		
30124		Removal of nose lesion	90	\$318		
30125		Removal of nose lesion	90	\$926		
30130		Removal of turbinate bones	90	\$413		
30140		Removal of turbinate bones	90	\$511		
30150		Partial removal of nose	90	\$1,237		
30160		Removal of nose	90	\$1,573		
30200		Injection treatment of nose	0	\$84		
30210		Nasal sinus therapy	10	\$94		
30220		Insert nasal septal button	10	\$224		
30300		Remove nasal foreign body	10	\$107		
30310		Remove nasal foreign body	10	\$263		
30320		Remove nasal foreign body	90	\$645		
30400		Reconstruction of nose	90	\$2,146		
30410		Reconstruction of nose	90	\$2,763		

LABOR AND EMPLOYMENT

CPT Code	Mod	Description	Global Days	Maximum Allowance	Non-Facility Maximum	Facility Maximum
30420		Reconstruction of nose	90	\$2,904		
30430		Revision of nose	90	\$1,976		
30435		Revision of nose	90	\$2,365		
30450		Revision of nose	90	\$3,177		
30460		Revision of nose	90	\$1,345		
30462		Revision of nose	90	\$2,691		
30465		Repair nasal stenosis		\$2,084		
30520		Repair of nasal septum	90	\$1,022		
30540		Repair nasal defect	90	\$1,047		
30545		Repair nasal defect	90	\$1,603		
30560		Release of nasal adhesions	10	\$129		
30580		Repair upper jaw fistula	90	\$942		
30600		Repair mouth/nose fistula	90	\$708		
30620		Intranasal reconstruction	90	\$1,082		
30630		Repair nasal septum defect	90	\$976		
30801		Cauterization inner nose	10	\$110		
30802		Cauterization inner nose	10	\$215		
30901		Control of nosebleed	0	\$130		
30903		Control of nosebleed	0	\$175		
30905		Control of nosebleed	0	\$278		
30906		Repeat control of nosebleed	0	\$258		
30915		Ligation nasal sinus artery	90	\$863		
30920		Ligation upper jaw artery	90	\$1,404		
30930		Therapy fracture of nose	10	\$142		
30999		Nasal surgery procedure		BR		
31000		Irrigation maxillary sinus	10	\$112		
31002		Irrigation sphenoid sinus	10	\$168		
31020		Exploration maxillary sinus	90	\$408		
31030		Exploration maxillary sinus	90	\$989		
31032		Explore sinus, remove polyps	90	\$1,118		
31040		Exploration behind upper jaw	90	\$1,251		
31050		Exploration sphenoid sinus	90	\$827		
31051		Sphenoid sinus surgery	90	\$1,120		
31070		Exploration of frontal sinus	90	\$654		
31075		Exploration of frontal sinus	90	\$1,429		
31080		Removal of frontal sinus	90	\$1,491		
31081		Removal of frontal sinus	90	\$1,666		
31084		Removal of frontal sinus	90	\$2,060		
31085		Removal of frontal sinus	90	\$2,180		
31086		Removal of frontal sinus	90	\$1,699		
31087		Removal of frontal sinus	90	\$1,689		
31090		Exploration of sinuses	90	\$1,529		
31200		Removal of ethmoid sinus	90	\$693		
31201		Removal of ethmoid sinus	90	\$1,110		
31205		Removal of ethmoid sinus	90	\$1,309		
31225		Removal of upper jaw	90	\$2,620		
31230		Removal of upper jaw	90	\$3,205		
31231		Nasal endoscopy, dx	0	\$129		
31233		Nasal/sinus endoscopy, dx	0	\$268		
31235		Nasal/sinus endoscopy, dx	0	\$469		
31237		Nasal/sinus endoscopy, surg	0	\$322		
31238		Nasal/sinus endoscopy, surg	0	\$559		
31239		Nasal/sinus endoscopy, surg	10	\$1,455		
31240		Nasal/sinus endoscopy, surg	0	\$448		
31254		Revision of ethmoid sinus	0	\$790		
31255		Removal of ethmoid sinus	0	\$1,191		
31256		Exploration maxillary sinus	0	\$523		
31267		Endoscopy, maxillary sinus	0	\$805		
31276		Sinus surgical endoscopy	0	\$1,041		
31287		Nasal/sinus endoscopy, surg	0	\$671		
31288		Nasal/sinus endoscopy, surg	0	\$784		
31290		Nasal/sinus endoscopy, surg	10	\$2,204		
31291		Nasal/sinus endoscopy, surg	10	\$2,315		
31292		Nasal/sinus endoscopy, surg	10	\$1,790		
31293		Nasal/sinus endoscopy, surg	10	\$1,958		
31294		Nasal/sinus endoscopy, surg	10	\$2,238		

Title 40, Part I

CPT Code	Mod	Description	Global Days	Maximum Allowance	Non-Facility Maximum	Facility Maximum
31295		Sinus endo w/balloon dil			\$4,436	\$353
31296		Sinus endo w/balloon dil			\$4,496	\$420
31297		Sinus endo w/balloon dil			\$4,422	\$346
31299		Sinus surgery procedure		BR		
31300		Removal of larynx lesion	90	\$1,851		
31320		Diagnostic incision larynx	90	\$630		
31360		Removal of larynx	90	\$2,601		
31365		Removal of larynx	90	\$3,685		
31367		Partial removal of larynx	90	\$2,695		
31368		Partial removal of larynx	90	\$3,790		
31370		Partial removal of larynx	90	\$2,659		
31375		Partial removal of larynx	90	\$2,471		
31380		Partial removal of larynx	90	\$2,665		
31382		Partial removal of larynx	90	\$2,573		
31390		Removal of larynx & pharynx	90	\$4,009		
31395		Reconstruct larynx & pharynx	90	\$4,622		
31400		Revision of larynx	90	\$1,259		
31420		Removal of epiglottis	90	\$1,273		
31500		Insert emergency airway	0	\$256		
31502		Change of windpipe airway	0	\$93		
31505		Diagnostic laryngoscopy	0	\$95		
31510		Laryngoscopy with biopsy	0	\$180		
31511		Remove foreign body, larynx	0	\$228		
31512		Removal of larynx lesion	0	\$287		
31513		Injection into vocal cord	0	\$396		
31515		Laryngoscopy for Aspiration	0	\$217		
31520		Diagnostic laryngoscopy	0	\$311		
31525		Diagnostic laryngoscopy	0	\$358		
31526		Diagnostic laryngoscopy	0	\$442		
31527		Laryngoscopy for treatment	0	\$465		
31528		Laryngoscopy and dilatation	0	\$378		
31529		Laryngoscopy and dilatation	0	\$382		
31530		Operative laryngoscopy	0	\$525		
31531		Operative laryngoscopy	0	\$671		
31535		Operative laryngoscopy	0	\$539		
31536		Operative laryngoscopy	0	\$619		
31540		Operative laryngoscopy	0	\$711		
31541		Operative laryngoscopy	0	\$737		
31545		Remove vc lesion w/scope		\$776		
31546		Remove vc lesion scope/graft		\$1,179		
31560		Operative laryngoscopy	0	\$777		
31561		Operative laryngoscopy	0	\$1,044		
31570		Laryngoscopy with injection	0	\$690		
31571		Laryngoscopy with injection	0	\$702		
31575		Diagnostic laryngoscopy	0	\$201		
31576		Laryngoscopy with biopsy	0	\$357		
31577		Remove foreign body, larynx	0	\$440		
31578		Removal of larynx lesion	0	\$531		
31579		Diagnostic laryngoscopy.	0	\$346		
31580		Revision of larynx	90	\$1,911		
31582		Revision of larynx	90	BR		
31584		Repair of larynx fracture	90	\$2,305		
31587		Revision of larynx	90	\$1,132		
31588		Revision of larynx	90	\$2,430		
31590		Reinnervate larynx	90	\$1,904		
31595		Larynx nerve surgery	90	\$1,074		
31599		Larynx surgery procedure		BR		
31600		Incision of windpipe	0	\$588		
31601		Incision of windpipe	0	\$719		
31603		Incision of windpipe	0	\$641		
31605		Incision of windpipe	0	\$586		
31610		Incision of windpipe	90	\$1,095		
31611		Surgery/speech prosthesis	90	\$1,020		
31612		Puncture/clear windpipe	0	\$161		
31613		Repair windpipe opening	90	\$476		
31614		Repair windpipe opening	90	\$962		

LABOR AND EMPLOYMENT

CPT Code	Mod	Description	Global Days	Maximum Allowance	Non-Facility Maximum	Facility Maximum
31615		Visualization of windpipe	0	\$301		
31620		Endobronchial us add-on			\$574	\$139
31622		Dx bronchoscope/wash..	0	\$435		
31623		Dx bronchoscope/brush	0	\$465		
31624		Dx bronchoscope/lavage	0	\$468		
31625		Bronchoscopy with biopsy	0	\$535		
31626		Bronchoscopy w/markers			\$928	\$425
31627		Navigational bronchoscopy			\$2,700	\$196
31628		Bronchoscopy with biopsy	0	\$642		
31629		Bronchoscopy with biopsy	0	\$568		
31630		Bronchoscopy with repair	0	\$570		
31631		Bronchoscopy with dilation	0	\$623		
31632		Bronchoscopy/lung bx addl			\$148	\$102
31633		Bronchoscopy/needle bx addl			\$181	\$131
31634		Bronch w/balloon occlusion		\$4,535		
31634		Bronch w/balloon occlusion			\$4,534	\$443
31635		Remove foreign body, airway	0	\$619		
31636		Bronchoscopy bronch stents		\$469		
31637		Bronchoscopy stent add-on		\$159		
31638		Bronchoscopy revise stent		\$540		
31640		Bronchoscopy & remove lesion	0	\$753		
31641		Bronchoscopy, treat blockage	0	\$928		
31643		Diag bronchoscope/catheter	0	\$498		
31645		Bronchoscopy, clear airways	0	\$502		
31646		Bronchoscopy_reclear airways	0	\$428		
31656		Bronchoscopy, inject for X-ray	0	\$393		
31715		Injection for bronchus x-ray	0	\$116		
31717		Bronchial brush biopsy	0	\$206		
31720		Clearance of airways..	0	\$155		
31725		Clearance of airways	0	\$250		
31730		Intro windpipe wire/tube	0	\$393		
31750		Repair of windpipe	90	\$1,347		
31755		Repair of windpipe	90	\$3,686		
31760		Repair of windpipe	90	\$2,432		
31766		Reconstruction of windpipe	90	\$3,421		
31770		Repair/graft of bronchus	90	\$2,712		
31775		Reconstruct bronchus	90	\$2,863		
31780		Reconstruct windpipe	90	\$2,516		
31781		Reconstruct windpipe	90	\$2,905		
31785		Remove windpipe lesion	90	\$1,857		
31786		Remove windpipe lesion	90	\$2,695		
31800		Repair of windpipe injury	90	\$1,023		
31805		Repair of windpipe injury	90	\$1,687		
31820		Closure of windpipe lesion	90	\$577		
31825		Repair of windpipe defect	90	\$843		
31830		Revise windpipe scar	90	\$591		
31899		Airways surgical procedure		BR		
32035		Exploration of chest	90	\$1,031		
32036		Exploration of chest	90	\$1,133		
32096		Open wedge/bx lung infiltr		\$1,703		
32097		Open wedge/bx lung nodule		\$1,703		
32098		Open biopsy of lung pleura		\$1,601		
32100		Exploration/biopsy of chest	90	\$1,657		
32110		Explore/repair chest	90	\$1,790		
32120		Re-exploration of chest	90	\$1,473		
32124		Explore chest, free adhesions	90	\$1,704		
32140		Removal of lung lesion(s)	90	\$1,907		
32141		Remove/treat lung lesions	90	\$1,989		
32150		Removal of lung lesion(s)	90	\$1,754		
32151		Remove lung foreign body	90	\$1,624		
32160		Open chest heart massage	90	\$1,273		
32200		Drain, open, lung lesion	90	\$1,760		
32201		Drain, percut, lung lesion	0	\$653		
32215		Treat chest lining	90	\$1,342		
32220		Release of lung	90	\$2,580		
32225		Partial release of lung	90	\$1,856		

Title 40, Part I

CPT Code	Mod	Description	Global Days	Maximum Allowance	Non-Facility Maximum	Facility Maximum
32310		Removal of chest lining	90	\$1,945		
32320		Free/remove chest lining	90	\$2,877		
32400		Needle biopsy chest lining	0	\$238		
32405		Biopsy, lung or mediastinum	0	\$299		
32420		Puncture/clear lung	0	\$270		
32421		Thoracentesis for aspiration			\$308	\$155
32422		Thoracentesis w/tube insert			\$391	\$249
32440		Removal of lung	90	\$2,921		
32442		Sleeve pneumonectomy	90	\$3,265		
32445		Removal of lung	90	\$3,377		
32480		Partial removal of lung	90	\$2,635		
32482		Bilobectomy	90	\$2,756		
32484		Segmentectomy	90	\$2,825		
32486		Sleeve lobectomy	90	\$3,010		
32488		Completion pneumonectomy	90	\$3,229		
32491		Lung volume reduction	90	\$2,823		
32501		Repair bronchus add-on		\$642		
32503		Resect apical lung tumor		\$3,845		
32504		Resect apical lung tum/chest		\$4,313		
32505		Wedge resect of lung initial		\$1,965		
32506		Wedge resect of lung add-on		\$332		
32507		Wedge resect of lung diag		\$332		
32520		Remove lung & revise chest	90	\$3,116		
32522		Remove lung & revise chest	90	\$3,400		
32525		Remove lung & revise chest	90	\$3,712		
32540		Removal of lung lesion	90	\$1,914		
32550		Insert pleural cath			\$1,624	\$461
32551		Insertion of chest tube		\$354		
32552		Remove lung catheter			\$396	\$344
32553		Ins mark thor for rt perq			\$1,209	\$428
32560		Treat pleurodesis w/agent			\$507	\$163
32561		Lyse chest fibrin init day			\$194	\$146
32562		Lyse chest fibrin subq day			\$175	\$131
32601		Thoracoscopy, diagnostic	0	\$673		
32604		Thoracoscopy, diagnostic	0	\$941		
32606		Thoracoscopy, diagnostic	0	\$914		
32607		Thoracoscopy w/bx infiltrate		\$653		
32608		Thoracoscopy w/bx nodule		\$802		
32609		Thoracoscopy w/bx pleura		\$554		
32653		Thoracoscopy, surgical	90	\$1,754		
32654		Thoracoscopy, surgical	90	\$1,790		
32655		Thoracoscopy, surgical	90	\$2,009		
32656		Thoracoscopy, surgical	90	\$1,970		
32657		Thoracoscopy, surgical	90	\$2,063		
32658		Thoracoscopy, surgical	90	\$1,902		
32659		Thoracoscopy, surgical	90	\$1,946		
32661		Thoracoscopy, surgical	90	\$1,658		
32662		Thoracoscopy, surgical	90	\$2,340		
32663		Thoracoscopy, surgical	90	\$2,677		
32664		Thoracoscopy, surgical	90	\$1,858		
32665		Thoracoscopy, surgical	90	\$2,244		
32666		Thoracoscopy w/wedge resect		\$1,837		
32667		Thoracoscopy w/w resect addl		\$332		
32668		Thoracoscopy w/w resect diag		\$334		
32669		Thoracoscopy remove segment		\$2,831		
32670		Thoracoscopy bilobectomy		\$3,379		
32671		Thoracoscopy pneumonectomy		\$3,751		
32672		Thoracoscopy for lvrs		\$3,208		
32673		Thoracoscopy w/thymus resect		\$2,530		
32674		Thoracoscopy lymph node exc		\$455		
32900		Removal of rib(s)	90	\$1,999		
32905		Revise & repair chest wall	90	\$2,441		
32906		Revise & repair chest wall	90	\$3,080		
32940		Revision of lung	90	\$2,213		
32960		Therapeutic pneumothorax	0	\$206		
32997		Total lung lavage.....	0	\$741		

LABOR AND EMPLOYMENT

CPT Code	Mod	Description	Global Days	Maximum Allowance	Non-Facility Maximum	Facility Maximum
32998		Perq rf ablate tx pul tumor		\$5,948		
32999		Chest surgery procedure		BR		
33010		Drainage of heart sac	0	\$278		
33011		Repeat drainage of heart sac	0	\$245		
33015		Incision of heart sac	90	\$745		
33020		Incision of heart sac	90	\$1,902		
33025		Incision of heart sac	90	\$1,946		
33030		Partial removal of heart sac	90	\$2,985		
33031		Partial removal of heart sac	90	\$2,506		
33050		Removal of heart sac lesion	90	\$1,658		
33120		Removal of heart lesion	90	\$4,009		
33130		Removal of heart lesion	90	\$2,495		
33140		Heart revascularize (tmr)	90	\$3,348		
33141		Heart tmr w/other procedure		\$280		
33202		Insert epicard eltrd open		\$1,635		
33203		Insert epicard eltrd endo		\$1,686		
33206		Insertion of heart pacemaker	90	\$1,101		
33207		Insertion of heart pacemaker	90	\$1,247		
33208		Insertion of heart pacemaker	90	\$1,377		
33210		Insertion of heart electrode	0	\$487		
33211		Insertion of heart electrode	0	\$494		
33212		Insertion of pulse generator	90	\$812		
33213		Insertion of pulse generator	90	\$879		
33214		Upgrade of pacemaker system	90	\$983		
33215		Reposition pacing-defib lead	90	\$619		
33216		Revise eltrd pacing- defib	90	\$769		
33217		Revise eltrd pacing- defib	90	\$806		
33218		Revise eltrd pacing- defib	90	\$748		
33220		Revise eltrd pacing- defib	90	\$760		
33221		Insert pulse gen mult leads		\$739		
33222		Pacemaker aicd pocket	90	\$800		
33223		Revise pocket, pacing-defib	90	\$928		
33224		Insert pacing lead & connect		\$1,034		
33225		L ventric pacing lead add-on		\$928		
33226		Reposition l ventric lead		\$995		
33227		Remove&replace pm gen singl		\$705		
33228		Remv&replc pm gen dual lead		\$735		
33229		Remv&replc pm gen mult leads		\$766		
33230		Insrt pulse gen w/dual leads		\$795		
33231		Insrt pulse gen w/mult leads		\$825		
33233		Removal of pacemaker system	90	\$440		
33234		Removal of pacemaker system	90	\$814		
33235		Removal pacemaker electrode	90	\$960		
33236		Remove electrode/thoracotomy	90	\$1,155		
33237		Removeelectrode/thoracotomy	90	\$1,680		
33238		Remove electrode/thoracotomy	90	\$1,872		
33240		Insert pulse generator	90	\$986		
33241		Remove pulse generator	90	\$436		
33243		Remove eltrd/ thoracotomy	90	\$2,408		
33244		Remove eltrd, transven	90	\$1,333		
33249		Eltrd/insert pace- defib	90	\$2,100		
33250		Ablate heart dysrhythm focus	90	\$2,263		
33251		Ablate heart dysrhythm focus	90	\$2,987		
33254		Ablate atria lmtd		\$2,902		
33255		Ablate atria w/o bypass ext		\$3,473		
33256		Ablate atria w/bypass exten		\$4,150		
33257		Ablate atria lmtd add-on		\$1,237		
33258		Ablate atria x10sv add-on		\$1,387		
33259		Ablate atria w/bypass add-on		\$1,796		
33261		Ablate heart dysrhythm focus	90	\$3,134		
33262		Remv&replc cvd gen sing lead		\$766		
33263		Remv&replc cvd gen dual lead		\$797		
33264		Remv&replc cvd gen mult lead		\$827		
33265		Ablate atria lmtd endo		\$2,870		
33266		Ablate atria x10sv endo		\$3,914		
33282		Implant pat-active ht record	90	\$650		

Title 40, Part I

CPT Code	Mod	Description	Global Days	Maximum Allowance	Non-Facility Maximum	Facility Maximum
33284		Remove pat-active ht record	90	\$465		
33300		Repair of heart wound	90	\$2,347		
33305		Repair of heart wound	90	\$2,809		
33310		Exploratory heart surgery	90	\$2,147		
33315		Exploratory heart surgery	90	\$2,633		
33320		Repair major blood vessel(s)	90	\$2,382		
33321		Repair major vessel	90	\$3,087		
33322		Repair major blood vessel(s)	90	\$3,097		
33330		Insert major vessel graft	90	\$2,651		
33332		Insert major vessel graft	90	\$2,797		
33335		Insert major vessel graft	90	\$3,195		
33400		Repair of aortic valve	90	\$3,695		
33401		Valvuloplasty, open	90	\$2,971		
33403		Valvuloplasty, w/cp bypass	90	\$3,100		
33404		Prepare heart-aorta conduit	90	\$3,522		
33405		Replacement of aortic valve	90	\$4,607		
33406		Replacement, aortic valve	90	\$4,746		
33410		Replacement of aortic valve	90	\$5,396		
33411		Replacement of aortic valve	90	\$5,413		
33412		Replacement of aortic valve	90	\$4,217		
33413		Replacement, aortic valve	90	\$4,521		
33414		Repair, aortic valve	90	\$3,874		
33415		Revision, subvalvular tissue	90	\$3,262		
33416		Revise ventricle muscle	90	\$4,341		
33417		Repair of aortic valve	90	\$3,521		
33420		Revision of mitral valve	90	\$3,041		
33422		Revision of mitral valve	90	\$4,387		
33425		Repair of mitral valve	90	\$4,407		
33426		Repair of mitral valve	90	\$4,518		
33427		Repair of mitral valve	90	\$5,173		
33430		Replacement of mitral valve	90	\$4,982		
33460		Revision of tricuspid valve	90	\$3,709		
33463		Valvuloplasty, tricuspid	90	\$3,197		
33464		Valvuloplasty, tricuspid	90	\$3,423		
33465		Replace tricuspid valve	90	\$4,615		
33468		Revision of tricuspid valve	90	\$3,664		
33470		Revision of pulmonary valve	90	\$2,610		
33471		Valvotomy, pulmonary valve	90	\$2,797		
33472		Revision of pulmonary valve	90	\$2,865		
33474		Revision of pulmonary valve	90	\$2,539		
33475		Replacement, pulmonary valve	90	\$3,617		
33476		Revision of heart chamber	90	\$3,237		
33478		Revision of heart chamber	90	\$3,345		
33496		Repair, prosth valve clot	90	\$4,301		
33500		Repair heart vessel fistula	90	\$2,993		
33501		Repair heart vessel fistula	90	\$2,443		
33502		Coronary artery correction	90	\$2,474		
33503		Coronary artery graft	90	\$2,460		
33504		Coronary artery graft	90	\$2,777		
33505		Repair artery w/tunnel	90	\$3,357		
33506		Repair artery, translocation	90	\$3,357		
33507		Repair art intramural		\$3,634		
33508		Endoscopic vein harvest		\$34		
33510		Cabg, vein, single	90	\$4,109		
33511		Cabg, vein, two	90	\$4,510		
33512		Cabg, vein, three	90	\$4,912		
33513		Cabg, vein, four	90	\$5,312		
33514		Cabg, vein, five	90	\$5,713		
33516		Cabg, vein, six+	90	\$6,114		
33517		Cabg, artery-vein, single		\$402		
33518		Cabg, artery-vein, two		\$803		
33519		Cabg, artery-vein, three		\$1,204		
33521		Cabg, artery-vein, four		\$1,605		
33522		Cabg, artery-vein, five		\$2,007		
33523		Cabg, artery-vein, six+		\$2,408		
33530		Coronary artery, bypass/reop		\$1,305		

LABOR AND EMPLOYMENT

CPT Code	Mod	Description	Global Days	Maximum Allowance	Non-Facility Maximum	Facility Maximum
33533		Cabg, arterial, single	90	\$4,234		
33534		Cabg, arterial, two	90	\$4,761		
33535		Cabg, arterial, three	90	\$5,288		
33536		Cabg, arterial, four+	90	\$5,815		
33542		Removal of heart lesion	90	\$4,448		
33545		Repair of heart damage	90	\$5,320		
33548		Restore/remodel ventricle		\$6,318		
33572		Open coronary endarterectomy		\$582		
33600		Closure of valve	90	\$3,746		
33602		Closure of valve	90	\$3,617		
33606		Anastomosis/artery-aorta	90	\$3,874		
33608		Repair anomaly w/conduit	90	\$3,972		
33610		Repair by enlargement	90	\$3,874		
33611		Repair double ventricle	90	\$4,133		
33612		Repair double ventricle	90	\$4,243		
33615		Repair (simple fontan)	90	\$4,035		
33617		Repair by modified fontan	90	\$4,262		
33619		Repair single ventricle	90	\$4,682		
33620		Apply r&l pulm art bands		\$3,513		
33621		Transhor cath for stent		\$1,888		
33622		Redo compl cardiac anomaly		\$7,398		
33641		Repair heart septum defect	90	\$3,574		
33645		Revision of heart veins	90	\$2,978		
33647		Repair heart septum defects	90	\$3,868		
33660		Repair of heart defects	90	\$3,739		
33665		Repair of heart defects	90	\$4,074		
33670		Repair of heart chambers	90	\$4,208		
33675		Close mult vsd		\$4,197		
33676		Close mult vsd w/resection		\$4,483		
33677		Cl mult vsd w/rem pul band		\$4,659		
33681		Repair heart septum defect	90	\$3,891		
33684		Repair heart septum defect	90	\$4,029		
33688		Repair heart septum defect	90	\$4,018		
33690		Reinforce pulmonary artery	90	\$2,531		
33692		Repair of heart defects	90	\$3,874		
33694		Repair of heart defects	90	\$4,153		
33697		Repair of heart defects.	90	\$5,344		
33702		Repair of heart defects	90	\$3,269		
33710		Repair of heart defects	90	\$4,327		
33720		Repair of heart defect	90	\$3,269		
33722		Repair of heart defect	90	\$3,617		
33724		Repair venous anomaly		\$3,253		
33726		Repair pul venous stenosis		\$4,343		
33730		Repair heart-vein defect(s)	90	\$4,343		
33732		Repair heart-vein defect	90	\$3,584		
33735		Revision of heart chamber	90	\$2,706		
33736		Revision of heart chamber	90	\$2,643		
33737		Revision of heart chamber	90	\$2,813		
33750		Major vessel shunt	90	\$2,841		
33755		Major vessel shunt	90	\$2,825		
33762		Major vessel shunt	90	\$2,879		
33764		Major vessel shunt and graft	90	\$2,754		
33766		Major vessel shunt	90	\$2,842		
33767		Atrial septectomy/septostomy	90	\$3,100		
33768		Cavopulmonary shunting		\$930		
33770		Repair great vessels defect	90	\$4,229		
33771		Repair great vessels defect	90	\$4,392		
33774		Repair great vessels defect	90	\$3,836		
33775		Repair great vessels defect	90	\$4,076		
33776		Repair great vessels defect	90	\$4,306		
33777		Repair great vessels defect	90	\$4,175		
33778		Repair great vessels defect	90	\$5,008		
33779		Repair great vessels defect	90	\$5,173		
33780		Repair great vessels defect	90	\$5,263		
33781		Repair great vessels defect	90	\$4,933		
33782		Nikaidoh proc		\$6,807		



Title 40, Part I

CPT Code	Mod	Description	Global Days	Maximum Allowance	Non-Facility Maximum	Facility Maximum
33783		Nikaidoh proc w/ostia implt		\$7,371		
33786		Repair arterial trunk	90	\$4,933		
33788		Revision of pulmonary	90	\$3,261		
33800		Aortic suspension	90	\$2,009		
33802		Repair vessel defect	90	\$2,312		
33803		Repair vessel defect	90	\$2,565		
33813		Repair septal defect	90	\$2,622		
33814		Repair septal defect	90	\$3,417		
33820		Revise major vessel	90	\$2,062		
33822		Revise major vessel	90	\$2,236		
33824		Revise major vessel	90	\$2,489		
33840		Remove aorta constriction	90	\$2,705		
33845		Remove aorta constriction	90	\$2,844		
33851		Remove aorta constriction	90	\$2,854		
33852		Repair septal defect	90	\$2,938		
33853		Repair septal defect	90	\$4,004		
33860		Ascending aorta graft	90	\$5,106		
33863		Ascending aorta graft	90	\$5,382		
33864		Ascending aortic graft		\$6,833		
33870		Transverse aortic arch graft	90	\$6,376		
33875		Thoracic aorta graft	90	\$4,515		
33877		Thoracoabdominal graft	90	\$6,567		
33880		Endovasc taa repr incl subcl		\$3,852		
33881		Endovasc taa repr w/o subcl		\$3,319		
33884		Endovasc prosth taa add-on		\$879		
33886		Endovasc prosth delayed		\$2,087		
33889		Artery transpose/endovas taa		\$1,715		
33910		Remove lung artery emboli	90	\$2,780		
33915		Remove lung artery emboli	90	\$2,341		
33916		Surgery of great vessel	90	\$3,198		
33917		Repair pulmonary artery	90	\$3,100		
33920		Repair pulmonary atresia	90	\$4,067		
33922		Transect pulmonary artery	90	\$2,971		
33924		Remove pulmonary shunt		\$700		
33925		Rpr pul art unifocal w/o cpb		\$3,622		
33926		Repr pul art unifocal w/cpb		\$5,187		
33930		Removal of donorheart/lung		BR		
33935		Transplantation, heart/lung	90	\$10,589		
33940		Removal of donor heart		BR		
33945		Transplantation of heart	90	BR		
33960		External circulation assist		\$1,934		
33961		External circulation assist.		\$1,378		
33967		Insert ia percut device		\$539		
33968		Remove aortic assist device	90	\$71		
33970		Aortic circulation assist	0	\$1,174		
33971		Aortic circulation assist	90	\$717		
33973		Insert balloon device	0	\$1,295		
33974		Remove intra-aortic balloon	90	\$1,356		
33975		Implant ventricular device		\$2,583		
33976		Implant ventricular device		\$3,519		
33977		Remove ventricular device	90	\$2,260		
33978		Remove ventricular device	90	\$2,583		
33979		Insert intracorporeal device		\$4,139		
33980		Remove intracorporeal device		\$3,791		
33981		Replace vad pump ext		\$1,784		
33982		Replace vad intra w/o bp		\$4,175		
33983		Replace vad intra w/bp		\$4,902		
33999		Cardiac surgery procedure		BR		
34001		Removal of artery clot	90	\$1,638		
34051		Removal of artery clot	90	\$1,701		
34101		Removal of artery clot	90	\$1,330		
34111		Removal of arm artery clot	90	\$1,158		
34151		Removal of artery clot	90	\$2,094		
34201		Removal of artery clot	90	\$1,326		
34203		Removal of leg artery clot	90	\$1,516		
34401		Removal of vein clot	90	\$1,494		

LABOR AND EMPLOYMENT

CPT Code	Mod	Description	Global Days	Maximum Allowance	Non-Facility Maximum	Facility Maximum
34421		Removal of vein clot	90	\$1,264		
34451		Removal of vein clot	90	\$1,838		
34471		Removal of vein clot	90	\$934		
34490		Removal of vein clot	90	\$1,085		
34501		Repair valve, femoral vein	90	\$1,947		
34502		Reconstruct, vena cava	90	\$3,394		
34510		Transposition of vein valve	90	\$2,493		
34520		Cross-over vein graft	90	\$1,046		
34530		Leg vein fusion	90	\$1,502		
34800		Endovas aaa repr w/sm tube		\$2,424		
34802		Endovas aaa repr w/2-p part		\$2,684		
34803		Endovas aaa repr w/3-p part		\$2,766		
34804		Endovas aaa repr w/1-p part		\$2,684		
34805		Endovas aaa repr w/long tube		\$2,573		
34806		Aneurysm press sensor add-on		\$220		
34808		Endovas iliac a device addon		\$442		
34812		Xpose for endoprosth femorl		\$727		
34813		Femoral endovas graft add-on		\$511		
34820		Xpose for endoprosth iliac		\$1,046		
34825		Endovasc extend prosth init		\$1,502		
34826		Endovasc exten prosth addl		\$441		
34830		Open aortic tube prosth repr		\$3,839		
34831		Open aortoiliac prosth repr		\$4,128		
34832		Open aortofemor prosth repr		\$4,128		
34833		Xpose for endoprosth iliac		\$1,312		
34834		Xpose endoprosth brachial		\$591		
34900		Endovasc iliac repr w/graft		\$1,917		
35001		Repair defect of artery	90	\$2,625		
35002		Repair artery rupture, neck	90	\$2,441		
35005		Repair defect of artery	90	\$2,123		
35011		Repair defect of artery	90	\$1,803		
35013		Repair artery rupture, arm	90	\$2,385		
35021		Repair defect of artery	90	\$2,763		
35022		Repair artery rupture, chest	90	\$2,742		
35045		Repair defect of arm artery	90	\$1,737		
35081		Repair defect of artery	90	\$3,651		
35082		Repair artery rupture, aorta	90	\$3,986		
35091		Repair defect of artery	90	\$4,299		
35092		Repair artery rupture, aorta	90	\$4,781		
35102		Repair defect of artery	90	\$3,912		
35103		Repair artery rupture, groin	90	\$4,437		
35111		Repair defect of artery	90	\$2,514		
35112		Repair artery rupture,	90	\$2,127		
35121		Repair defect of artery	90	\$3,334		
35122		Repair artery rupture, belly	90	\$3,820		
35131		Repair defect of artery	90	\$2,553		
35132		Repair artery rupture, groin	90	\$3,020		
35141		Repair defect of artery	90	\$2,146		
35142		Repair artery rupture, thigh	90	\$2,404		
35151		Repair defect of artery	90	\$2,393		
35152		Repair artery rupture, knee	90	\$1,888		
35180		Repair blood vessel lesion	90	\$1,488		
35182		Repair blood vessel lesion	90	\$2,009		
35184		Repair blood vessel lesion	90	\$1,592		
35188		Repair blood vessel lesion	90	\$1,615		
35189		Repair blood vessel lesion	90	\$2,170		
35190		Repair blood vessel lesion	90	\$1,718		
35201		Repair blood vessel lesion	90	\$1,480		
35206		Repair blood vessel lesion	90	\$1,463		
35207		Repair blood vessel lesion	90	\$1,543		
35211		Repair blood vessel lesion	90	\$2,557		
35216		Repair blood vessel lesion	90	\$2,115		
35221		Repair blood vessel lesion	90	\$2,010		
35226		Repair blood vessel lesion	90	\$1,444		
35231		Repair blood vessel lesion	90	\$2,009		
35236		Repair blood vessel lesion	90	\$1,697		

Title 40, Part I

CPT Code	Mod	Description	Global Days	Maximum Allowance	Non-Facility Maximum	Facility Maximum
35241		Repair blood vessel lesion	90	\$2,637		
35246		Repair blood vessel lesion	90	\$2,636		
35251		Repair blood vessel lesion	90	\$1,953		
35256		Repair blood vessel lesion	90	\$1,765		
35261		Repair blood vessel lesion	90	\$1,856		
35266		Repair blood vessel lesion	90	\$1,633		
35271		Repair blood vessel lesion	90	\$2,495		
35276		Repair blood vessel lesion	90	\$2,140		
35286		Repair blood vessel lesion	90	\$1,757		
35301		Rechanneling of artery	90	\$2,352		
35302		Rechanneling of artery		\$2,457		
35303		Rechanneling of artery		\$2,704		
35304		Rechanneling of artery		\$2,779		
35305		Rechanneling of artery		\$2,684		
35306		Rechanneling of artery		\$971		
35311		Rechanneling of artery	90	\$3,489		
35321		Rechanneling of artery	90	\$1,892		
35331		Rechanneling of artery	90	\$2,701		
35341		Rechanneling of artery	90	\$3,155		
35351		Rechanneling of artery	90	\$2,624		
35355		Rechanneling of artery	90	\$2,373		
35361		Rechanneling of artery	90	\$3,214		
35363		Rechanneling of artery	90	\$3,563		
35371		Rechanneling of artery	90	\$1,806		
35372		Rechanneling of artery	90	\$1,824		
35381		Rechanneling of artery	90	\$2,186		
35390		Reoperation, carotid add-on		\$366		
35400		Angioscopy.....		\$378		
35450		Repair arterial blockage	0	\$1,723		
35452		Repair arterial blockage	0	\$841		
35458		Repair arterial blockage	0	\$1,424		
35460		Repair venous blockage	0	\$705		
35471		Repair arterial blockage	0	\$1,723		
35472		Repair arterial blockage	0	\$805		
35475		Repair arterial blockage	0	\$1,424		
35476		Repair venous blockage	0	\$705		
35500		Harvest vein for bypass		\$693		
35501		Artery bypass graft	90	\$2,908		
35506		Artery bypass graft	90	\$2,905		
35508		Artery bypass graft	90	\$2,743		
35509		Artery bypass graft	90	\$2,798		
35510		Artery bypass graft		\$2,681		
35511		Artery bypass graft	90	\$1,962		
35512		Artery bypass graft		\$2,630		
35515		Artery bypass graft	90	\$2,157		
35516		Artery bypass graft	90	\$2,534		
35518		Artery bypass graft	90	\$2,471		
35521		Artery bypass graft	90	\$2,525		
35522		Artery bypass graft		\$2,551		
35523		Artery bypass graft		\$2,776		
35526		Artery bypass graft	90	\$2,408		
35531		Artery bypass graft	90	\$3,421		
35533		Artery bypass graft	90	\$3,158		
35535		Artery bypass graft		\$3,730		
35536		Artery bypass graft	90	\$3,341		
35537		Artery bypass graft		\$4,543		
35538		Artery bypass graft		\$5,086		
35539		Artery bypass graft		\$4,778		
35540		Artery bypass graft		\$5,573		
35556		Artery bypass graft	90	\$2,682		
35558		Artery bypass graft	90	\$2,298		
35560		Artery bypass graft	90	\$3,275		
35563		Artery bypass graft	90	\$1,688		
35565		Artery bypass graft	90	\$2,480		
35566		Artery bypass graft	90	\$3,179		
35570		Artery bypass graft		\$3,014		

LABOR AND EMPLOYMENT

CPT Code	Mod	Description	Global Days	Maximum Allowance	Non-Facility Maximum	Facility Maximum
35571		Artery bypass graft	90	\$2,824		
35572		Harvest femoropopliteal vein		\$747		
35583		Vein bypass graft	90	\$2,870		
35585		Vein bypass graft	90	\$3,301		
35587		Vein bypass graft	90	\$3,024		
35600		Harvest art for cabg add-on		\$546		
35601		Artery bypass graft	90	\$2,715		
35606		Artery bypass graft	90	\$2,723		
35612		Artery bypass graft	90	\$2,439		
35616		Artery bypass graft	90	\$2,450		
35621		Artery bypass graft	90	\$2,454		
35623		Bypass graft, not vein	90	\$1,795		
35626		Artery bypass graft	90	\$3,317		
35631		Artery bypass graft	90	\$3,157		
35632		Artery bypass graft		\$3,542		
35633		Artery bypass graft		\$3,919		
35634		Artery bypass graft		\$3,574		
35636		Artery bypass graft...	90	\$2,677		
35637		Artery bypass graft		\$3,776		
35638		Artery bypass graft		\$3,848		
35642		Artery bypass graft	90	\$2,069		
35645		Artery bypass graft	90	\$2,080		
35646		Artery bypass graft	90	\$3,717		
35647		Artery bypass graft		\$3,369		
35650		Artery bypass graft	90	\$2,359		
35654		Artery bypass graft	90	\$3,125		
35656		Artery bypass graft	90	\$2,491		
35661		Artery bypass graft	90	\$2,165		
35663		Artery bypass graft	90	\$2,373		
35665		Artery bypass graft	90	\$2,507		
35666		Artery bypass graft	90	\$2,833		
35671		Artery bypass graft	90	\$2,484		
35681		Composite bypass graft		\$854		
35682		Composite bypass graft		\$1,260		
35683		Composite bypass graft		\$1,360		
35685		Bypass graft patency/patch		\$432		
35686		Bypass graft/av fist patency		\$359		
35691		Arterial transposition	90	\$2,841		
35693		Arterial transposition	90	\$1,792		
35694		Arterial transposition	90	\$2,075		
35695		Arterial transposition	90	\$2,075		
35697		Reimplant artery each		\$321		
35700		Reoperation, bypass graft		\$359		
35701		Exploration, carotid artery	90	\$851		
35721		Exploration, femoral artery	90	\$794		
35741		Exploration popliteal artery	90	\$808		
35761		Exploration of artery/vein	90	\$813		
35800		Explore neck vessels	90	\$871		
35820		Explore chest vessels	90	\$1,487		
35840		Explore abdominal vessels	90	\$1,225		
35860		Explore limb vessels	90	\$814		
35870		Repair vessel graft defect	90	\$2,711		
35875		Removal of clot in graft	90	\$1,369		
35876		Removal of clot in graft	90	\$1,612		
35879		Revise graft w/vein	90	\$2,022		
35881		Revise graft w/vein...	90	\$2,231		
35883		Revise graft w/nonauto graft		\$2,634		
35884		Revise graft w/vein		\$2,704		
35901		Excision, graft, neck	90	\$1,125		
35903		Excision, graft, extremity	90	\$1,223		
35905		Excision, graft, thorax	90	\$1,808		
35907		Excision, graft, abdomen	90	\$1,864		
36000		Place needle in vein		\$44		
36002		Pseudoaneurysm injection trt			\$331	\$220
36005		Injection, venography	0	\$104		
36010		Place catheter in vein		\$343		

Title 40, Part I

CPT Code	Mod	Description	Global Days	Maximum Allowance	Non-Facility Maximum	Facility Maximum
36011		Place catheter in vein		\$372		
36012		Place catheter in vein		\$461		
36013		Place catheter in artery		\$350		
36014		Place catheter in artery		\$395		
36015		Place catheter in artery		\$461		
36100		Establish access to artery		\$420		
36120		Establish access to artery		\$328		
36140		Establish access to artery		\$259		
36147		Access av dial grft for eval			\$1,800	\$387
36148		Access av dial grft for proc			\$554	\$102
36160		Establish access to aorta		\$368		
36200		Place catheter in aorta		\$427		
36215		Place catheter in artery		\$530		
36216		Place catheter in artery		\$626		
36217		Place catheter in artery		\$746		
36218		Place catheter in artery.		\$136		
36245		Place catheter in artery		\$601		
36246		Place catheter in artery		\$626		
36247		Place catheter in artery		\$746		
36248		Place catheter in artery.		\$136		
36251		Ins cath ren art 1st unilat			\$3,016	\$578
36252		Ins cath ren art 1st bilat			\$3,310	\$753
36253		Ins cath ren art 2nd+ unilat			\$4,614	\$804
36254		Ins cath ren art 2nd+ bilat			\$4,801	\$868
36260		Insertion of infusion pump	90	\$1,234		
36261		Revision of infusion pump	90	\$544		
36262		Removal of infusion pump	90	\$427		
36299		Vessel injection procedure		BR		
36400		Drawing blood		\$20		
36405		Drawing blood		\$47		
36406		Drawing blood		\$25		
36410		Drawing blood		\$30		
36415		Drawing blood		BR		
36420		Establish access to vein		\$112		
36425		Establish access to vein		\$61		
36430		Blood transfusion service		\$73		
36440		Blood transfusion service		\$145		
36450		Exchange transfusion service		\$304		
36455		Exchange transfusion service		\$349		
36460		Transfusion service, fetal		\$748		
36468		Injection(s);spider veins		BR		
36469		Injection(s);spider veins		BR		
36470		Injection therapy of vein	10	\$94		
36471		Injection therapy of veins	10	\$137		
36475		Endovenous rf 1st vein			\$3,670	\$740
36476		Endovenous rf vein add-on			\$826	\$364
36478		Endovenous laser 1st vein			\$2,867	\$737
36479		Endovenous laser vein addon			\$858	\$365
36481		Insertion of catheter, vein	0	\$914		
36500		Insertion of catheter, vein	0	\$256		
36510		Insertion of catheter, vein	0	\$103		
36511		Apheresis wbc		\$199		
36512		Apheresis rbc		\$191		
36513		Apheresis platelets		\$210		
36514		Apheresis plasma			\$1,047	\$192
36515		Apheresis adsorp/reinfuse			\$4,529	\$195
36516		Apheresis selective			\$4,112	\$144
36520		Plasma and/or cell exchange	0	\$250		
36522		Photopheresis	0	\$438		
36555		Insert non-tunnel cv cath			\$557	\$249
36556		Insert non-tunnel cv cath			\$485	\$252
36557		Insert tunneled cv cath			\$2,127	\$681
36558		Insert tunneled cv cath			\$1,604	\$576
36560		Insert tunneled cv cath			\$2,829	\$760
36561		Insert tunneled cv cath			\$2,463	\$739
36563		Insert tunneled cv cath			\$2,817	\$792

LABOR AND EMPLOYMENT

CPT Code	Mod	Description	Global Days	Maximum Allowance	Non-Facility Maximum	Facility Maximum
36565		Insert tunneled cv cath			\$2,090	\$734
36566		Insert tunneled cv cath			\$11,204	\$795
36568		Insert picc cath			\$579	\$196
36569		Insert picc cath			\$493	\$186
36570		Insert picvad cath			\$2,415	\$637
36571		Insert picvad cath			\$2,697	\$670
36575		Repair tunneled cv cath			\$339	\$73
36576		Repair tunneled cv cath			\$784	\$404
36578		Replace tunneled cv cath			\$1,065	\$448
36580		Replace cvad cath			\$432	\$137
36581		Replace tunneled cv cath			\$1,555	\$406
36582		Replace tunneled cv cath			\$2,299	\$637
36583		Replace tunneled cv cath			\$2,483	\$670
36584		Replace picc cath			\$403	\$135
36585		Replace picvad cath			\$2,315	\$578
36589		Removal tunneled cv cath			\$343	\$289
36590		Removal tunneled cv cath			\$611	\$428
36591		Draw blood off venous device		\$46		
36592		Collect blood from picc		\$52		
36593		Declot vascular device		\$61		
36595		Mech remov tunneled cv cath			\$1,139	\$379
36596		Mech remov tunneled cv cath			\$271	\$92
36597		Reposition venous catheter			\$251	\$124
36598		Inj w/fluor eval cv device			\$225	\$74
36600		Withdrawal of arterial blood		\$44		
36620		Insertion catheter, artery	0	\$138		
36625		Insertion catheter, artery	0	\$223		
36640		Insertion catheter, artery	0	\$341		
36660		Insertion catheter, artery	0	\$138		
36680		Insert needle, bone cavity	0	\$180		
36800		Insertion of cannula..	0	\$338		
36810		Insertion of cannula	0	\$677		
36815		Insertion of cannula	0	\$474		
36818		Av fuse uppr arm cephalic		\$1,441		
36819		Av fusion by basilic vein	90	\$1,588		
36820		Av fusion/forearm vein		\$1,734		
36821		Av fusion direct any site	90	\$1,202		
36822		Insertion of cannula(s)	90	\$870		
36823		Insertion of cannula(s)		\$2,805		
36825		Artery-vein graft.....	90	\$1,522		
36830		Artery-vein graft	90	\$1,465		
36831		Av fistula excision...	90	\$824		
36832		Av fistula revision...	90	\$1,372		
36833		Av fistula revision...	90	\$1,248		
36835		Artery to vein shunt..	90	\$811		
36838		Dist revas ligation hemo		\$2,480		
36860		External cannula declotting	0	\$356		
36861		Cannula declotting	0	\$555		
36870		Percut thrombect av fistula			\$3,924	\$623
37140		Revision of circulation	90	\$2,948		
37145		Revision of circulation	90	\$2,974		
37160		Revision of circulation	90	\$2,950		
37180		Revision of circulation	90	\$2,840		
37181		Splice spleen/kidney veins	90	\$3,192		
37182		Insert hepatic shunt (tips)		\$1,731		
37183		Remove hepatic shunt (tips)			\$11,797	\$807
37184		Prim art mech thrombectomy			\$4,710	\$939
37185		Prim art m-thrombect add-on			\$1,532	\$347
37186		Sec art m-thrombect add-on			\$2,965	\$526
37187		Venous mech thrombectomy			\$4,459	\$843
37188		Venous m-thrombectomy add-on			\$3,745	\$600
37191		Ins endovas vena cava filtr			\$5,485	\$494
37192		Redo endovas vena cava filtr			\$3,678	\$764
37193		Rem endovas vena cava filter			\$3,510	\$764
37195		Thrombolytic therapy, stroke		\$605		
37200		Transcatheter biopsy	0	\$445		

Title 40, Part I

CPT Code	Mod	Description	Global Days	Maximum Allowance	Non-Facility Maximum	Facility Maximum
37201		Transcatheter therapy infuse	0	\$948		
37202		Transcatheter therapy	0	\$742		
37203		Transcatheter retrieval	0	\$658		
37204		Transcatheter occlusion	0	\$2,371		
37205		Transcatheter stent	0	\$981		
37206		Transcatheter stent add-on.		\$487		
37207		Transcatheter stent	0	\$981		
37208		Transcatheter stent add-on		\$479		
37209		Exchange arterial catheter	0	\$174		
37210		Embolization uterine fibroid			\$7,372	\$1,071
37215		Transcath stent cca w/eps		\$2,269		
37216		Transcath stent cca w/o eps		\$2,111		
37220		Iliac revasc			\$6,769	\$875
37221		Iliac revasc w/stent			\$10,110	\$1,066
37222		Iliac revasc add-on			\$1,941	\$397
37223		Iliac revasc w/stent add-on			\$5,541	\$450
37224		Fem/popl revas w/tla			\$8,142	\$963
37225		Fem/popl revas w/ather			\$23,125	\$1,301
37226		Fem/popl revasc w/stent			\$19,512	\$1,073
37227		Fem/popl revasc stnt & ather			\$31,278	\$1,571
37228		Tib/per revasc w/tla			\$11,636	\$1,178
37229		Tib/per revasc w/ather			\$22,868	\$1,523
37230		Tib/per revasc w/stent			\$18,117	\$1,469
37231		Tib/per revasc stent & ather			\$29,130	\$1,597
37232		Tib/per revasc add-on			\$2,601	\$426
37233		Tibper revasc w/ather add-on			\$3,157	\$701
37234		Revasc opn/prq tib/pero stent			\$8,335	\$583
37235		Tib/per revasc stnt & ather			\$8,890	\$828
37250		Iv us first vessel add on		\$249		
37251		Iv us each add vessel add-on		\$193		
37500		Endoscopy ligate perf veins		\$1,483		
37565		Ligation of neck vein	90	\$616		
37600		Ligation of neck artery	90	\$737		
37605		Ligation of neck artery	90	\$795		
37606		Ligation of neck artery	90	\$816		
37607		Ligation of fistula	90	\$681		
37609		Temporal artery procedure	10	\$345		
37615		Ligation of neck artery	90	\$833		
37616		Ligation of chest artery	90	\$1,397		
37617		Ligation of abdomen artery	90	\$1,680		
37618		Ligation of extremity artery	90	\$704		
37619		Ligation of inf vena cava		\$3,429		
37650		Revision of major vein	90	\$676		
37660		Revision of major vein	90	\$1,242		
37700		Revise leg vein	90	\$559		
37718		Ligate/strip short leg vein		\$943		
37722		Ligate/strip long leg vein		\$1,042		
37735		Removal of leg veins/lesion	90	\$1,410		
37760		Revision of leg veins	90	\$1,338		
37761		Ligate leg veins open		\$1,186		
37765		Stab phleb veins xtr 10-20		\$1,413		
37766		Phleb veins - extrem 20+			\$1,660	\$1,173
37780		Revision of leg vein	90	\$408		
37785		Revise secondary varicosity	90	\$334		
37788		Revascularization, penis	90	\$2,851		
37790		Penile venous occlusion	90	\$861		
37799		Vascular surgery procedure		BR		
38100		Removal of spleen, total	90	\$1,582		
38101		Removal of spleen, partial	90	\$1,494		
38102		Removal of spleen, total		\$546		
38115		Repair of ruptured spleen	90	\$1,538		
38120		Laparoscopy, splenectomy		\$2,187		
38129		Laparoscopy proc, spleen		BR		
38200		Injection for spleen X-ray	0	\$319		
38204		BI donor search management		\$209		
38205		Harvest allogenic stem cells		\$163		

LABOR AND EMPLOYMENT

CPT Code	Mod	Description	Global Days	Maximum Allowance	Non-Facility Maximum	Facility Maximum
38206		Harvest auto stem cells		\$168		
38207		Cryopreserve stem cells		\$92		
38208		Thaw preserved stem cells		\$59		
38209		Wash harvest stem cells		\$25		
38210		T-cell depletion of harvest		\$164		
38211		Tumor cell deplete of harvest		\$149		
38212		Rbc depletion of harvest		\$97		
38213		Platelet deplete of harvest		\$25		
38214		Volume deplete of harvest		\$84		
38215		Harvest stem cell concentrte		\$97		
38220		Bone marrow aspiration			\$324	\$124
38221		Bone marrow biopsy			\$332	\$152
38230		Bone marrow collection	10	\$436		
38232		Bone marrow harvest autolog		\$383		
38240		Bone marrow/stem transplant		\$308		
38241		Bone marrow transplantation		\$312		
38242		Lymphocyte infuse transplant		\$196		
38300		Drainage lymph node lesion	10	\$154		
38305		Drainage lymph node lesion	90	\$465		
38308		Incision of lymph channels	90	\$593		
38380		Thoracic duct procedure	90	\$831		
38381		Thoracic duct procedure	90	\$1,498		
38382		Thoracic duct procedure	90	\$1,076		
38500		Biopsy/removal,lymph node(s)	10	\$335		
38505		Needle biopsy, lymph node(s)	0	\$172		
38510		Biopsy/removal,lymph node(s)	90	\$488		
38520		Biopsy/removal,lymph node(s)	90	\$595		
38525		Biopsy/removal,lymph node(s)	90	\$531		
38530		Biopsy/removal,lymph node(s)	90	\$683		
38542		Explore deep node(s), neck	90	\$727		
38550		Removal, neck/armpit lesion	90	\$750		
38555		Removal, neck/armpit lesion	90	\$1,649		
38562		Removal, pelvic lymph nodes	90	\$1,256		
38564		Removal, abdomen lymph nodes	90	\$1,338		
38570		Laparoscopy, lymph node biop	10	\$1,101		
38571		Laparoscopy, lymphadenectomy	10	\$1,619		
38572		Laparoscopy, lymphadenectomy	10	\$1,977		
38589		Laparoscope proc, lymphatic		BR		
38700		Removal of lymph nodes, neck	90	\$1,310		
38720		Removal of lymph nodes, neck	90	\$2,128		
38724		Removal of lymph nodes, neck	90	\$2,094		
38740		Remove armpit lymph nodes	90	\$850		
38745		Remove armpits lymph nodes	90	\$1,283		
38746		Remove thoracic lymph nodes		\$508		
38747		Remove abdominal lymph v		\$560		
38760		Remove groin lymph nodes	90	\$1,145		
38765		Remove groin lymph nodes	90	\$2,129		
38770		Remove pelvis lymph nodes	90	\$2,069		
38780		Remove abdomen lymph nodes	90	\$2,432		
38790		Inject for lymphatic X ray	0	\$757		
38792		Identify sentinel node	0	\$84		
38794		Access thoracic lymph duct	90	\$515		
38900		Io map of sent lymph node		\$279		
38999		Blood/lymph system procedure		BR		
39000		Exploration of chest..	90	\$982		
39010		Exploration of chest..	90	\$1,790		
39200		Removal chest lesion	90	\$1,849		
39220		Removal chest lesion	90	\$2,402		
39400		Visualization of chest	10	\$792		
39499		Chest procedure		BR		
39501		Repair diaphragm laceration	90	\$1,800		
39503		Repair of diaphragm hernia	90	\$4,342		
39540		Repair of diaphragm hernia	90	\$1,882		
39541		Repair of diaphragm hernia	90	\$1,957		
39545		Revision of diaphragm	90	\$1,624		
39560		Resect diaphragm, simple	90	\$1,645		



Title 40, Part I

CPT Code	Mod	Description	Global Days	Maximum Allowance	Non-Facility Maximum	Facility Maximum
39561		Resect diaphragm, complex	90	\$2,601		
39599		Diaphragm surgery procedure		BR		
40490		Biopsy of lip	0	\$144		
40500		Partial excision of lip	90	\$797		
40510		Partial excision of lip	90	\$796		
40520		Partial excision of lip	90	\$689		
40525		Reconstruct lip with flap	90	\$1,274		
40527		Reconstruct lip with flap	90	\$1,524		
40530		Partial removal of lip	90	\$778		
40650		Repair lip	90	\$610		
40652		Repair lip	90	\$716		
40654		Repair lip	90	\$899		
40700		Repair cleft lip/nasal	90	\$1,541		
40701		Repair cleft lip/nasal	90	\$2,553		
40702		Repair cleft lip/nasal	90	\$1,615		
40720		Repair cleft lip/nasal	90	\$1,720		
40761		Repair cleft lip/nasal	90	\$1,882		
40799		Lip surgery procedure		BR		
40800		Drainage of mouth lesion	10	\$137		
40801		Drainage of mouth lesion	10	\$308		
40804		Removal foreign body, mouth	10	\$130		
40805		Removal foreign body, mouth	10	\$385		
40806		Incision of lip fold	0	\$49		
40808		Biopsy of mouth lesion	10	\$124		
40810		Excision of mouth lesion	10	\$180		
40812		Excise/repair mouth lesion	10	\$277		
40814		Excise/repair mouth lesion	90	\$483		
40816		Excision of mouth lesion	90	\$501		
40818		Excise oral mucosa for graft	90	\$334		
40819		Excise lip or cheek fold	90	\$257		
40820		Treatment of mouth lesion	10	\$129		
40830		Repair mouth laceration	10	\$174		
40831		Repair mouth laceration	10	\$323		
40840		Reconstruction of mouth	90		\$1,672	\$1,282
40842		Reconstruction of mouth	90		\$1,683	\$1,341
40843		Reconstruction of mouth	90		\$2,291	\$1,825
40844		Reconstruction of mouth	90		\$2,851	\$2,321
40845		Reconstruction of mouth	90		\$3,084	\$2,582
40899		Mouth surgery procedure		BR		
41000		Drainage of mouth lesion	10	\$148		
41005		Drainage of mouth lesion	10	\$135		
41006		Drainage of mouth lesion	90	\$294		
41007		Drainage of mouth lesion	90	\$431		
41008		Drainage of mouth lesion	90	\$307		
41009		Drainage of mouth lesion	90	\$496		
41010		Incision of tongue fold	10	\$113		
41015		Drainage of mouth lesion	90	\$332		
41016		Drainage of mouth lesion	90	\$551		
41017		Drainage of mouth lesion	90	\$373		
41018		Drainage of mouth lesion	90	\$641		
41019		Place needles h&n for rt		\$941		
41100		Biopsy of tongue	10	\$175		
41105		Biopsy of tongue	10	\$179		
41108		Biopsy of floor of mouth	10	\$138		
41110		Excision of tongue lesion	10	\$206		
41112		Excision of tongue lesion	90	\$372		
41113		Excision of tongue lesion	90	\$486		
41114		Excision of tongue lesion	90	\$1,062		
41115		Excision of tongue fold	10	\$258		
41116		Excision of mouth lesion	90	\$363		
41120		Partial removal of tongue	90	\$1,203		
41130		Partial removal of tongue	90	\$1,449		
41135		Tongue and neck surgery	90	\$2,578		
41140		Removal of tongue	90	\$3,171		
41145		Tongue removal; neck surgery	90	\$3,774		
41150		Tongue, mouth, jaw surgery	90	\$2,887		

LABOR AND EMPLOYMENT

CPT Code	Mod	Description	Global Days	Maximum Allowance	Non-Facility Maximum	Facility Maximum
41153		Tongue, mouth, neck surgery	90	\$3,484		
41155		Tongue, jaw, & neck surgery	90	\$4,042		
41250		Repair tongue laceration	10	\$215		
41251		Repair tongue laceration	10	\$318		
41252		Repair tongue laceration	10	\$392		
41500		Fixation of tongue	90	\$500		
41510		Tongue to lip surgery	90	\$446		
41512		Tongue suspension		\$1,348		
41520		Reconstruction, tongue fold	90	\$410		
41530		Tongue base vol reduction			\$7,038	\$872
41599		Tongue and mouth surgery		BR		
41800		Drainage of gum lesion	10	\$133		
41805		Removal foreign body, gum	10	\$150		
41806		Removal foreign body, jawbone	10	\$314		
41820		Excision, gum, each quadrant		BR		
41821		Excision of gum flap		BR		
41822		Excision of gum lesion	10		\$605	\$382
41823		Excision of gum lesion	90		\$891	\$677
41825		Excision of gum lesion	10	\$205		
41826		Excision of gum lesion	10	\$320		
41827		Excision of gum lesion	90	\$526		
41828		Excision of gum lesion	10	\$509		
41830		Removal of gum tissue	10		\$817	\$593
41850		Treatment of gum lesion		BR		
41870		Gum graft		BR		
41872		Repair gum.....	90	\$397		
41874		Repair tooth socket...	90	\$467		
41899		Dental surgery procedure		BR		
42000		Drainage mouth roof lesion	10	\$132		
42100		Biopsy roof of mouth	10	\$151		
42104		Excision lesion, mouth roof	10	\$240		
42106		Excision lesion, mouth roof	10	\$358		
42107		Excision lesion, mouth roof	90	\$681		
42120		Remove palate/lesion	90	\$999		
42140		Excision of uvula	90	\$215		
42145		Repair, palate, pharynx/uvula	90	\$1,449		
42160		Treatment mouth roof lesion	10	\$244		
42180		Repair palate	10	\$350		
42182		Repair palate	10	\$540		
42200		Reconstruct cleft palate	90	\$1,241		
42205		Reconstruct cleft palate	90	\$1,456		
42210		Reconstruct cleft palate	90	\$1,662		
42215		Reconstruct cleft palate	90	\$1,201		
42220		Reconstruct cleft palate	90	\$910		
42225		Reconstruct cleft palate	90	\$1,208		
42226		Lengthening of palate	90	\$1,286		
42227		Lengthening of palate	90	\$1,181		
42235		Repair palate	90	\$959		
42260		Repair nose to lip fistula	90	\$608		
42280		Preparation, palate mold	10	\$259		
42281		Insertion, palate prosthesis	10	\$241		
42299		Palate/uvula surgery		BR		
42300		Drainage of salivary gland	10	\$210		
42305		Drainage of salivary gland	90	\$569		
42310		Drainage of salivary gland	10	\$189		
42320		Drainage of salivary gland	10	\$308		
42330		Removal of salivary stone	10	\$239		
42335		Removal of salivary stone	90	\$422		
42340		Removal of salivary stone	90	\$650		
42400		Biopsy of salivary gland	0	\$119		
42405		Biopsy of salivary gland	10	\$353		
42408		Excision of salivary cyst	90	\$569		
42409		Drainage of salivary cyst	90	\$412		
42410		Excise parotid gland/lesion	90	\$1,115		
42415		Excise parotid gland/lesion	90	\$2,158		
42420		Excise parotid gland/lesion	90	\$2,500		

Title 40, Part I

CPT Code	Mod	Description	Global Days	Maximum Allowance	Non-Facility Maximum	Facility Maximum
42425		Excise parotid gland/lesion	90	\$1,762		
42426		Excise parotid gland/lesion	90	\$3,342		
42440		Excision submaxillary gland	90	\$1,103		
42450		Excision sublingual gland	90	\$577		
42500		Repair salivary duct	90	\$650		
42505		Repair salivary duct	90	\$1,000		
42507		Parotid duct diversion	90	\$799		
42508		Parotid duct diversion	90	\$1,217		
42509		Parotid duct diversion	90	\$1,389		
42510		Parotid duct diversion	90	\$1,148		
42550		Injection for salivary X-ray	0	\$122		
42600		Closure of salivary fistula	90	\$633		
42650		Dilation of salivary duct	0	\$85		
42660		Dilation of salivary duct	0	\$120		
42665		Ligation of salivary duct	90	\$334		
42699		Salivary surgery procedure		BR		
42700		Drainage of tonsil abscess	10	\$179		
42720		Drainage of throat abscess	10	\$334		
42725		Drainage of throat abscess	90	\$891		
42800		Biopsy of throat	10	\$153		
42802		Biopsy of throat	10	\$187		
42804		Biopsy of upper nose/throat	10	\$171		
42806		Biopsy of upper nose/throat	10	\$220		
42808		Excise pharynx lesion	10	\$358		
42809		Remove pharynx foreign body	10	\$189		
42810		Excision of neck cyst	90	\$483		
42815		Excision of neck cyst	90	\$1,157		
42820		Remove tonsils and adenoids	90	\$500		
42821		Remove tonsils and adenoids	90	\$602		
42825		Removal of tonsils	90	\$438		
42826		Removal of tonsils	90	\$530		
42830		Removal of adenoids	90	\$327		
42831		Removal of adenoids	90	\$370		
42835		Removal of adenoids	90	\$296		
42836		Removal of adenoids	90	\$439		
42842		Extensive surgery of throat	90	\$1,101		
42844		Extensive surgery of throat	90	\$1,759		
42845		Extensive surgery of throat	90	\$3,024		
42860		Excision of tonsil tags	90	\$300		
42870		Excision of lingual tonsil	90	\$549		
42890		Partial removal of pharynx	90	\$1,536		
42892		Revision of pharyngeal walls	90	\$1,850		
42894		Revision of pharyngeal walls	90	\$2,730		
42900		Repair throat wound	10	\$689		
42950		Reconstruction of throat	90	\$1,321		
42953		Repair throat, esophagus	90	\$1,096		
42955		Surgical opening of throat	90	\$726		
42960		Control throat bleeding	10	\$247		
42961		Control throat bleeding	90	\$504		
42962		Control throat bleeding	90	\$942		
42970		Control nose/throat bleeding	90	\$418		
42971		Control nose/throat bleeding	90	\$623		
42972		Control nose/throat bleeding	90	\$838		
42999		Throat surgery procedure		BR		
43020		Incision of esophagus	90	\$1,063		
43030		Throat muscle surgery	90	\$1,240		
43045		Incision of esophagus.	90	\$2,471		
43100		Excision of esophagus lesion	90	\$1,208		
43101		Excision of esophagus lesion	90	\$1,957		
43107		Removal of esophagus	90	\$3,788		
43108		Removal of esophagus	90	\$4,388		
43112		Removal of esophagus	90	\$3,888		
43113		Removal of esophagus	90	\$4,457		
43116		Partial removal of esophagus	90	\$4,180		
43117		Partial removal of esophagus	90	\$4,096		
43118		Partial removal of esophagus	90	\$4,318		

LABOR AND EMPLOYMENT

CPT Code	Mod	Description	Global Days	Maximum Allowance	Non-Facility Maximum	Facility Maximum
43121		Partial removal of esophagus	90	\$3,727		
43122		Partial removal of esophagus	90	\$3,727		
43123		Partial removal of esophagus	90	\$4,318		
43124		Removal of esophagus	90	\$3,616		
43130		Removal of esophagus pouch	90	\$1,614		
43135		Removal of esophagus pouch	90	\$2,053		
43200		Esophagus endoscopy	0	\$301		
43201		Esoph scope w/submucous inj			\$654	\$267
43202		Esophagus endoscopy, biopsy	0	\$362		
43204		Esophagus endoscopy & inject	0	\$639		
43205		Esophagus endoscopy/ligation	0	\$469		
43215		Esophagus endoscopy	0	\$494		
43216		Esophagus endoscopy/ligation	0	\$512		
43217		Esophagus endoscopy	0	\$512		
43219		Esophagus endoscopy	0	\$484		
43220		Esophagus endoscopy, dilation	0	\$364		
43226		Esophagus endoscopy, dilation	0	\$428		
43227		Esophagus endoscopy, repair	0	\$605		
43228		Esophagus endoscopy, ablation	0	\$633		
43231		Esoph endoscopy w/us exam		\$401		
43232		Esoph endoscopy w/us fn bx		\$546		
43234		Upper gi endoscopy, exam	0	\$360		
43235		Upper gi endoscopy, diagnosis	0	\$427		
43236		Uppr gi scope w/submuc inj			\$795	\$364
43237		Endoscopic us exam esoph		\$490		
43238		Uppr gi endoscopy w/us fn bx		\$612		
43239		Upper gi endoscopy, biopsy	0	\$486		
43240		Esoph endoscope w/drain cyst		\$831		
43241		Upper gi endoscopy with Tube	0	\$502		
43242		Uppr gi endoscopy w/us fn bx		\$887		
43243		Upper gi endoscopy & inject	0	\$749		
43244		Upper gi endoscopy/ligation	0	\$569		
43245		Operative upper gi endoscopy	0	\$580		
43246		Place gastrostomy tube	0	\$738		
43247		Operative upper gi endoscopy	0	\$582		
43248		Upper gi endoscopy/guidewire	0	\$392		
43249		Esophagus endoscopy, dilation	0	\$485		
43250		Upper gi endoscopy/tumor	0	\$634		
43251		Operative upper gi endoscopy	0	\$634		
43255		Operative upper gi endoscopy	0	\$737		
43256		Uppr gi endoscopy w/stent		\$532		
43257		Uppr gi scope w/thrml txmnt		\$679		
43258		Operative upper gi endoscopy	0	\$732		
43259		Endoscopic ultrasound exam	0	\$486		
43260		Endoscopy,bile duct/pancreas	0	\$873		
43261		Endoscopy,bile duct/pancreas	0	\$895		
43262		Endoscopy,bile duct/pancreas	0	\$1,202		
43263		Endoscopy,bile duct/pancreas	0	\$878		
43264		Endoscopy,bile duct/pancreas	0	\$1,305		
43265		Endoscopy,bile duct/pancreas	0	\$1,148		
43267		Endoscopy,bile duct/pancreas	0	\$1,082		
43268		Endoscopy,bile duct/pancreas	0	\$1,181		
43269		Endoscopy,bile duct/pancreas	0	\$985		
43271		Endoscopy,bile duct/pancreas	0	\$1,099		
43272		Endoscopy,bile duct/pancreas	0	\$949		
43273		Endoscopic pancreatoscopy		\$264		
43279		Lap myotomy heller		\$2,691		
43280		Laparoscopy, fundoplasty	90	\$2,250		
43281		Lap paraesophag hern repair		\$3,211		
43282		Lap paraesoph her rpr w/mesh		\$3,611		
43283		Lap esoph lengthening		\$333		
43289		Laparoscope proc, esoph		BR		
43300		Repair of esophagus	90	\$1,533		
43305		Repair esophagus and fistula	90	\$2,239		
43310		Repair of esophagus	90	\$3,145		
43312		Repair esophagus and fistula	90	\$3,064		

Title 40, Part I

CPT Code	Mod	Description	Global Days	Maximum Allowance	Non-Facility Maximum	Facility Maximum
43313		Esophagoplasty congenital		\$6,062		
43314		Tracheo-esophagoplasty cong		\$6,054		
43320		Fuse esophagus & stomach.	90	\$2,087		
43325		Revise esophagus & stomach	90	\$2,020		
43327		Esoph fundoplasty lap		\$1,698		
43328		Esoph fundoplasty thor		\$2,484		
43330		Repair of esophagus...	90	\$2,075		
43331		Repair of esophagus	90	\$2,244		
43332		Transab esoph hiat hern rpr		\$2,418		
43333		Transab esoph hiat hern rpr		\$2,625		
43334		Transthor diaphrag hern rpr		\$2,647		
43335		Transthor diaphrag hern rpr		\$2,850		
43336		Thorabd diaphr hern repair		\$3,126		
43337		Thorabd diaphr hern repair		\$3,421		
43338		Esoph lengthening		\$273		
43340		Fuse esophagus & intestine	90	\$2,062		
43341		Fuse esophagus & intestine	90	\$1,892		
43350		Surgical opening, esophagus	90	\$1,436		
43351		Surgical opening, esophagus	90	\$1,680		
43352		Surgical opening, esophagus	90	\$1,505		
43360		Gastrointestinal repair	90	\$3,613		
43361		Gastrointestinal repair	90	\$4,180		
43400		Ligate esophagus veins	90	\$1,982		
43401		Esophagus surgery for veins	90	\$1,967		
43405		Ligate/staple esophagus	90	\$2,227		
43410		Repair esophagus wound	90	\$1,420		
43415		Repair esophagus wound	90	\$2,251		
43420		Repair esophagus opening	90	\$1,193		
43425		Repair esophagus opening	90	\$2,029		
43450		Dilate esophagus	0	\$150		
43453		Dilate esophagus	0	\$222		
43456		Dilate esophagus	0	\$441		
43458		Dilation of esophagus	0	\$269		
43460		Pressure treatment esophagus	0	\$398		
43496		Free jejunum flap, microvasc	90	BR		
43499		Esophagus surgery procedure		BR		
43500		Surgical opening of stomach	90	\$1,057		
43501		Surgical repair of stomach	90	\$1,794		
43502		Surgical repair of stomach	90	\$1,836		
43510		Surgical opening of stomach	90	\$1,327		
43520		Incision of pyloric muscle	90	\$875		
43605		Biopsy of stomach	90	\$1,092		
43610		Excision of stomach lesion	90	\$1,415		
43611		Excision of stomach lesion	90	\$1,580		
43620		Removal of stomach	90	\$2,803		
43621		Removal of stomach	90	\$2,835		
43622		Removal of stomach	90	\$2,930		
43631		Removal of stomach, partial	90	\$2,349		
43632		Removal stomach, partial	90	\$2,349		
43633		Removal stomach, partial	90	\$2,380		
43634		Removal stomach, partial	90	\$3,206		
43635		Partial removal of stomach		\$241		
43640		Vagotomy & pylorus repair	90	\$1,827		
43641		Vagotomy & pylorus repair	90	\$1,826		
43644		Lap gastric bypass/roux-en-y		\$3,594		
43645		Lap gastr bypass incl smll i		\$3,848		
43651		Laparoscopy, vagus nerve	90	\$1,360		
43652		Laparoscopy, vagus nerve	90	\$1,588		
43653		Laparoscopy, gastrostomy	90	\$1,191		
43659		Laparoscope proc, stom		BR		
43752		Nasal/orogastric w/stent		\$83		
43753		Tx gastro intub w/asp		\$43		
43754		Dx gastr intub w/asp spec			\$174	\$66
43755		Dx gastr intub w/asp specs			\$263	\$119
43756		Dx duod intub w/asp spec			\$484	\$107
43757		Dx duod intub w/asp specs			\$683	\$162

LABOR AND EMPLOYMENT

CPT Code	Mod	Description	Global Days	Maximum Allowance	Non-Facility Maximum	Facility Maximum
43760		Change gastrostomy tube	0	\$133		
43761		Reposition gastrostomy tube	0	\$226		
43770		Lap place gastr adj device		\$2,322		
43771		Lap revise gastr adj device		\$2,637		
43772		Lap rmvl gastr adj device		\$1,981		
43773		Lap replace gastr adj device		\$2,635		
43774		Lap rmvl gastr adj all parts		\$1,995		
43775		Lap sleeve gastrectomy		\$2,653		
43800		Reconstruction of pylorus	90	\$1,256		
43810		Fusion of stomach and bowel	90	\$1,363		
43820		Fusion of stomach and bowel	90	\$1,499		
43825		Fusion of stomach and bowel	90	\$1,888		
43830		Place gastrostomy tube	90	\$1,003		
43831		Place gastrostomy tube	90	\$888		
43832		Place gastrostomy tube	90	\$1,474		
43840		Repair of stomach lesion	90	\$1,413		
43842		Gastroplasty for obesity	90	\$2,126		
43843		Gastroplasty for obesity	90	\$2,131		
43845		Gastroplasty duodenal switch		\$4,059		
43846		Gastric bypass for obesity	90	\$2,556		
43847		Gastric bypass for obesity	90	\$2,147		
43848		Revision gastroplasty	90	\$2,814		
43850		Revise stomach-bowel fusion	90	\$2,267		
43855		Revise stomach-bowel fusion	90	\$2,257		
43860		Revise stomach-bowel fusion	90	\$2,273		
43865		Revise stomach-bowel fusion	90	\$2,514		
43870		Repair stomach opening	90	\$953		
43880		Repair stomach-bowel fistula	90	\$1,993		
43886		Revise gastric port open		\$754		
43887		Remove gastric port open		\$681		
43888		Change gastric port open		\$954		
43999		Stomach surgery procedure		BR		
44005		Freeing of bowel adhesion	90	\$1,596		
44010		Incision of small bowel	90	\$1,244		
44015		Insert needle cath bowel		\$390		
44020		Exploration of small bowel	90	\$1,427		
44021		Decompress small bowel	90	\$1,368		
44025		Incision of large bowel	90	\$1,446		
44050		Reduce bowel obstruction	90	\$1,378		
44055		Correct malrotation of bowel	90	\$1,500		
44100		Biopsy of bowel	0	\$250		
44110		Excision of bowel lesion(s)	90	\$1,293		
44111		Excision of bowel lesion(s)	90	\$1,618		
44120		Removal of small intestine	90	\$1,793		
44121		Removal of small intestine		\$508		
44125		Removal of small intestine	90	\$1,916		
44126		Enterectomy w/o taper cong		\$5,115		
44127		Enterectomy w/taper cong		\$5,912		
44128		Enterectomy cong add-on		\$504		
44130		Bowel to bowel fusion	90	\$1,575		
44139		Mobilization of colon		\$257		
44140		Partial removal of colon	90	\$2,189		
44141		Partial removal of colon	90	\$2,261		
44143		Partial removal of colon	90	\$2,128		
44144		Partial removal of colon	90	\$2,107		
44145		Partial removal of colon	90	\$2,707		
44146		Partial removal of colon	90	\$2,921		
44147		Partial removal of colon	90	\$2,534		
44150		Removal of colon	90	\$2,623		
44151		Removal of colon/ileostomy	90	\$2,150		
44155		Removal of colon	90	\$2,991		
44156		Removal of colon/ileostomy	90	\$2,436		
44157		Colectomy w/ileoanal anast		\$4,527		
44160		Removal of colon	90	\$2,068		
44180		Lap enterolysis		\$1,910		
44186		Lap jejunostomy		\$1,355		

Title 40, Part I

CPT Code	Mod	Description	Global Days	Maximum Allowance	Non-Facility Maximum	Facility Maximum
44187		Lap ileo/jejuno-stomy		\$2,311		
44188		Lap colostomy		\$2,557		
44202		Laparo, resect intestine	90	BR		
44203		Lap resect s/intestine addl		\$504		
44204		Laparo partial colectomy		\$3,206		
44205		Lap colectomy part w/ileum		\$2,789		
44206		Lap part colectomy w/stoma		\$3,658		
44207		L colectomy/coloproctostomy		\$3,811		
44208		L colectomy/coloproctostomy		\$4,148		
44210		Laparo total proctocolectomy		\$3,748		
44211		Lap colectomy w/proctectomy		\$4,693		
44212		Laparo total proctocolectomy		\$4,313		
44213		Lap mobil splenic fl add-on		\$393		
44227		Lap close enterostomy		\$3,476		
44300		Open bowel to skin	90	\$1,069		
44310		Ileostomy/jejunostomy	90	\$1,389		
44312		Revision of ileostomy	90	\$628		
44314		Revision of ileostomy	90	\$1,250		
44316		Devise bowel pouch	90	\$1,746		
44320		Colostomy	90	\$1,446		
44322		Colostomy with biopsies	90	\$1,505		
44340		Revision of colostomy	90	\$492		
44345		Revision of colostomy	90	\$1,127		
44346		Revision of colostomy	90	\$1,356		
44360		Small bowel endoscopy	0	\$494		
44361		Small bowel endoscopy, biopsy	0	\$567		
44363		Small bowel endoscopy	0	\$516		
44364		Small bowel endoscopy	0	\$679		
44365		Small bowel endoscopy	0	\$671		
44366		Small bowel endoscopy	0	\$799		
44369		Small bowel endoscopy	0	\$866		
44370		Small bowel endoscopy/stent		\$600		
44372		Small bowel endoscopy	0	\$812		
44373		Small bowel endoscopy	0	\$682		
44376		Small bowel endoscopy	0	\$668		
44377		Small bowel endoscopy	0	\$707		
44378		Small bowel endoscopy	0	\$922		
44379		S bowel endoscope w/stent		\$921		
44380		Small bowel endoscopy	0	\$278		
44382		Small bowel endoscopy	0	\$355		
44383		Ileoscopy w/stent		\$339		
44385		Endoscopy of bowel pouch	0	\$348		
44386		Endoscopy, bowel pouch, biops	0	\$270		
44388		Colon endoscopy	0	\$491		
44389		Colonoscopy with biopsy	0	\$537		
44390		Colonoscopy for foreign body	0	\$477		
44391		Colonoscopy for bleeding	0	\$717		
44392		Colonoscopy & polypectomy	0	\$707		
44393		Colonoscopy, lesion removal	0	\$775		
44394		Colonoscopy w/snare	0	\$707		
44397		Colonoscopy w/stent		\$579		
44500		Intro, gastrointestinal tube	0	\$46		
44602		Suture, small intestine	90	\$1,345		
44603		Suture, small intestine	90	\$1,698		
44604		Suture, large intestine	90	\$1,592		
44605		Repair of bowel lesion	90	\$1,790		
44615		Intestinal stricturoplasty	90	\$1,323		
44620		Repair bowel opening	90	\$1,195		
44625		Repair bowel opening..	90	\$1,716		
44626		Repair bowel opening..	90	\$2,541		
44640		Repair bowel-skin fistula	90	\$1,503		
44650		Repair bowel fistula	90	\$1,596		
44660		Repair bowel-bladder fistula	90	\$1,606		
44661		Repair bowel-bladder fistula	90	\$2,259		
44680		Surgical revision, intestine	90	\$1,718		
44700		Suspend bowel w/prosthesis	90	\$1,923		

LABOR AND EMPLOYMENT

CPT Code	Mod	Description	Global Days	Maximum Allowance	Non-Facility Maximum	Facility Maximum
44701		Intraop colon lavage add-on		\$348		
44720		Prep donor intestine/venous		\$507		
44721		Prep donor intestine/artery		\$798		
44799		Intestine surgery procedure		BR		
44800		Excision of bowel pouch	90	\$1,164		
44820		Excision of mesentery lesion	90	\$1,155		
44850		Repair of mesentery	90	\$1,092		
44899		Bowel surgery procedure		BR		
44900		Drain app abscess, open	90	\$1,004		
44901		Drain app abscess, percut	0	\$457		
44950		Appendectomy	90	\$847		
44955		Appendectomy add-on...		\$248		
44960		Appendectomy	90	\$1,197		
44970		Laparoscopy, appendectomy	90	\$1,246		
44979		Laparoscopy proc. app.		BR		
45000		Drainage of pelvic abscess	90	\$433		
45005		Drainage of rectal abscess	10	\$245		
45020		Drainage of rectal abscess	90	\$533		
45100		Biopsy of rectum	90	\$397		
45108		Removal of anorectal lesion	90	\$530		
45110		Removal of rectum.....	90	\$2,993		
45111		Partial removal of rectum.	90	\$2,121		
45112		Removal of rectum.....	90	\$3,139		
45113		Partial proctectomy	90	\$3,088		
45114		Partial removal of rectum	90	\$2,886		
45116		Partial removal of rectum	90	\$2,280		
45119		Remove rectum w/reservoir	90	\$3,158		
45120		Removal of rectum.....	90	\$3,066		
45121		Removal of rectum and colon	90	\$2,852		
45123		Partial proctectomy	90	\$1,927		
45126		Pelvic exenteration...	90	\$4,017		
45130		Excision of rectal prolapse	90	\$1,680		
45135		Excision of rectal prolapse	90	\$2,464		
45136		Excise ileoanal reservoir		\$3,800		
45150		Excision of rectal stricture	90	\$657		
45160		Excision of rectal lesion	90	\$1,541		
45171		Exc rect tum transanal part		\$1,254		
45172		Exc rect tum transanal full		\$1,696		
45190		Destruction rectal tumor	90	\$984		
45300		Proctosigmoidoscopy	0	\$94		
45303		Proctosigmoidoscopy	0	\$96		
45305		Proctosigmoidoscopy; biopsy	0	\$141		
45307		Proctosigmoidoscopy	0	\$224		
45308		Proctosigmoidoscopy	0	\$229		
45309		Proctosigmoidoscopy	0	\$229		
45315		Proctosigmoidoscopy	0	\$239		
45317		Proctosigmoidoscopy	0	\$296		
45320		Proctosigmoidoscopy	0	\$360		
45321		Proctosigmoidoscopy	0	\$273		
45327		Proctosigmoidoscopy w/stent		\$254		
45330		Sigmoidoscopy, diagnostic	0	\$164		
45331		Sigmoidoscopy and biopsy	0	\$215		
45332		Sigmoidoscopy	0	\$275		
45333		Sigmoidoscopy & polypectomy	0	\$330		
45334		Sigmoidoscopy for bleeding	0	\$420		
45335		Sigmoidoscopy w/submuc inj		\$585		
45337		Sigmoidoscopy, decompression	0	\$417		
45338		Sigmoidoscopy	0	\$330		
45339		Sigmoidoscopy	0	\$474		
45340		Sig w/balloon dilation			\$1,036	\$242
45341		Sigmoidoscopy w/ultrasound		\$329		
45342		Sigmoidoscopy w/us guide bx		\$502		
45345		Sigmoidoscopy w/stent		\$365		
45355		Surgical colonoscopy	0	\$339		
45378		Diagnostic colonoscopy	0	\$582		
45379		Colonoscopy	0	\$744		



Title 40, Part I

CPT Code	Mod	Description	Global Days	Maximum Allowance	Non-Facility Maximum	Facility Maximum
45380		Colonoscopy and biopsy	0	\$651		
45381		Colonoscopy submucous inj			\$984	\$512
45382		Colonoscopy,control bleeding		\$850		
45383		Colonoscopy, lesion removal	0	\$871		
45384		Colonoscopy	0	\$880		
45385		Colonoscopy, lesion removal	0	\$880		
45386		Colonoscopy dilate stricture			\$1,412	\$554
45387		Colonoscopy w/stent		\$725		
45391		Colonoscopy w/endscope us		\$619		
45392		Colonoscopy w/endoscopic fmb		\$797		
45395		Lap removal of rectum		\$4,152		
45397		Lap remove rectum w/pouch		\$4,490		
45400		Laparoscopic proc		\$2,409		
45402		Lap proctopexy w/sig resect		\$3,193		
45500		Repair of rectum	90	\$973		
45505		Repair of rectum	90	\$924		
45520		Treatment of rectal prolapse	0	\$90		
45540		Correct rectal prolapse	90	\$1,697		
45541		Correct rectal prolapse	90	\$1,557		
45550		Repair rectum;remove sigmoid	90	\$1,930		
45560		Repair of rectocele	90	\$938		
45562		Exploration/repair of rectum	90	\$1,456		
45563		Exploration/repair of rectum	90	\$2,297		
45800		Repair rectumbladder fistula	90	\$1,701		
45805		Repair fistula; colostomy	90	\$2,110		
45820		Repair rectourethral fistula	90	\$1,665		
45825		Repair fistula; colostomy	90	\$1,910		
45900		Reduction of rectal prolapse	10	\$168		
45905		Dilation of anal sphincter	10	\$166		
45910		Dilation of rectal narrowing	10	\$203		
45915		Remove rectal obstruction	10	\$210		
45990		Surg dx exam anorectal		\$222		
45999		Rectum surgery procedure		BR		
46020		Placement of seton			\$573	\$487
46030		Removal of rectal marker	10	\$118		
46040		Incision of rectal abscess	90	\$490		
46045		Incision of rectal abscess	90	\$434		
46050		Incision of anal abscess	10	\$131		
46060		Incision of rectal abscess	90	\$815		
46070		Incision of anal septum	90	\$307		
46080		Incision of anal sphincter	10	\$348		
46083		Incise external hemorrhoid	10	\$146		
46200		Removal of anal fissure	90	\$494		
46220		Removal of anal tab	10	\$161		
46221		Ligation of hemorrhoid(s)	10	\$155		
46230		Removal of anal tabs	10	\$246		
46250		Hemorrhoidectomy	90	\$542		
46255		Hemorrhoidectomy	90	\$745		
46257		Remove hemorrhoids & fissure	90	\$863		
46258		Remove hemorrhoids & fistula	90	\$945		
46260		Hemorrhoidectomy	90	\$992		
46261		Remove hemorrhoids & fissure	90	\$1,026		
46262		Remove hemorrhoids & fistula	90	\$1,054		
46270		Removal of anal fistula	90	\$407		
46275		Removal of anal fistula	90	\$777		
46280		Removal of anal fistula	90	\$917		
46285		Removal of anal fistula	90	\$467		
46288		Repair of anal fistula	90	\$786		
46320		Removal of hemorrhoid clot	10	\$170		
46505		Chemodenervation anal musc			\$594	\$498
46600		Diagnostic anoscopy	0	\$58		
46604		Anoscopy and dilation	0	\$124		
46606		Anoscopy and biopsy	0	\$87		
46608		Anoscopy;remove foreign body	0	\$192		
46610		Anoscopy; remove lesion	0	\$178		
46611		Anoscopy	0	\$178		

LABOR AND EMPLOYMENT

CPT Code	Mod	Description	Global Days	Maximum Allowance	Non-Facility Maximum	Facility Maximum
46612		Anoscopy; remove lesions	0	\$227		
46614		Anoscopy; control bleeding	0	\$270		
46615		Anoscopy	0	\$318		
46700		Repair of anal stricture	90	\$976		
46705		Repair of anal stricture	90	\$761		
46706		Repr of anal fistula w/glue		\$347		
46707		Repair anorectal fist w/plug		\$963		
46710		Repr per/vag pouch snl proc		\$2,270		
46712		Repr per/vag pouch dbl proc		\$4,249		
46715		Repair of anovaginal fistula	90	\$783		
46716		Repair of anovaginal fistula	90	\$1,348		
46730		Construction of absent anus	90	\$2,392		
46735		Construction of absent anus	90	\$2,901		
46740		Construction of absent anus	90	\$2,571		
46742		Repair, imperforated anus	90	\$3,504		
46744		Repair, cloacal anomaly	90	\$3,934		
46746		Repair, cloacal anomaly	90	\$4,304		
46748		Repair, cloacal anomaly	90	\$4,795		
46750		Repair of anal sphincter	90	\$1,032		
46751		Repair of anal sphincter	90	\$907		
46753		Reconstruction of anus	90	\$846		
46754		Removal of suture from anus	10	\$234		
46760		Repair of anal sphincter	90	\$1,333		
46761		Repair of anal sphincter	90	\$1,299		
46762		Implant artificial sphincter	90	\$1,146		
46900		Destruction, anal lesion(s)	10	\$160		
46910		Destruction, anal lesion(s)	10	\$180		
46916		Cryosurgery, anal lesion(s)	10	\$180		
46917		Laser surgery,anal lesion(s)	10	\$287		
46922		Excision of anal lesion(s)	10	\$235		
46924		Destruction, anal lesion(s)	10	\$406		
46930		Destroy internal hemorrhoids			\$422	\$306
46940		Treatment of anal fissure	10	\$206		
46942		Treatment of anal fissure	10	\$181		
46945		Ligation of hemorrhoids	90	\$270		
46946		Ligation of hemorrhoids	90	\$364		
46947		Hemorrhoidopexy by stapling		\$797		
46999		Anus surgery procedure		BR		
47000		Needle biopsy of liver	0	\$342		
47001		Needle biopsy, liver add-on		\$234		
47010		Open drainage, liver lesion	90	\$1,302		
47011		Percut drain, liver lesion	0	\$538		
47015		Inject/aspirate liver cyst	90	\$1,166		
47100		Wedge biopsy of liver	90	\$833		
47120		Partial removal of liver	90	\$2,440		
47122		Extensive removal of liver	90	\$3,802		
47125		Partial removal of liver	90	\$3,519		
47130		Partial removal of liver	90	\$3,867		
47133		Removal of donor liver		BR		
47135		Transplantation of liver	90	\$10,022		
47136		Transplantation of liver	90	\$7,373		
47140		Partial removal donor liver		\$7,241		
47141		Partial removal donor liver		\$8,173		
47142		Partial removal donor liver		\$9,745		
47146		Prep donor liver/venous		\$683		
47147		Prep donor liver/arterial		\$796		
47300		Surgery for liver lesion	90	\$1,276		
47350		Repair liver wound....	90	\$1,509		
47360		Repair liver wound....	90	\$2,128		
47361		Repair liver wound....	90	\$3,402		
47362		Repair liver wound....	90	\$1,333		
47370		Laparo ablate liver tumor rf		\$2,552		
47371		Laparo ablate liver cryosurg		\$2,606		
47380		Open ablate liver tumor rf		\$2,954		
47381		Open ablate liver tumor cryo		\$3,070		
47399		Liver surgery procedure		BR		

Title 40, Part I

CPT Code	Mod	Description	Global Days	Maximum Allowance	Non-Facility Maximum	Facility Maximum
47400		Incision of liver duct	90	\$2,038		
47420		Incision of bile duct	90	\$1,975		
47425		Incision of bile duct	90	\$2,049		
47460		Incise bile duct sphincter	90	\$2,187		
47480		Incision of gallbladder	90	\$1,221		
47490		Incision of gallbladder	90	\$707		
47500		Injection for liver X-rays	0	\$256		
47505		Injection for liver X-rays	0	\$158		
47510		Insert catheter, bile duct	90	\$744		
47511		Insert bile duct drain	90	\$922		
47525		Change bile duct catheter	10	\$507		
47530		Revise/reinsert bile tube	90	\$589		
47550		Bile duct endoscopy add-on		\$341		
47552		Biliary endoscopy, thru skin	0	\$539		
47553		Biliary endoscopy, thru skin	0	\$763		
47554		Biliary endoscopy, thru skin	0	\$967		
47555		Biliary endoscopy, thru skin	0	\$742		
47556		Biliary endoscopy, thru skin	0	\$814		
47560		Laparoscopy w/cholangio	90	\$556		
47561		Laparo w/cholangio/biopsy	0	\$610		
47562		Laparoscopic cholecystectomy	90	\$1,558		
47563		Laparo cholecystectomy graph	90	\$1,483		
47564		Laparo cholecystectomy explr	90	\$2,309		
47570		Laparo cholecystoenterostomy	90	\$1,608		
47579		Laparoscope proc, biliary		BR		
47600		Removal of gallbladder	90	\$1,401		
47605		Removal of gallbladder	90	\$1,517		
47610		Removal of gallbladder	90	\$1,785		
47612		Removal of gallbladder	90	\$2,267		
47620		Removal of gallbladder	90	\$2,080		
47630		Remove bile duct stone	90	\$882		
47700		Exploration of bile ducts	90	\$1,625		
47701		Bile duct revision	90	\$2,597		
47711		Excision of bile duct tumor	90	\$2,288		
47712		Excision of bile duct tumor	90	\$2,678		
47715		Excision of bile duct cyst	90	\$1,729		
47720		Fuse gallbladder & bowel	90	\$1,627		
47721		Fuse upper gi structures	90	\$2,004		
47740		Fuse gallbladder & bowel	90	\$1,860		
47741		Fuse gallbladder & bowel	90	\$2,352		
47760		Fuse bile ducts and bowel.	90	\$2,515		
47765		Fuse liver ducts & bowel.	90	\$2,668		
47780		Fuse bile ducts and bowel	90	\$2,563		
47785		Fuse bile ducts and bowel	90	\$2,815		
47800		Reconstruction of bile ducts	90	\$2,362		
47801		Placement, bile duct support	90	\$1,244		
47802		Fuse liver duct & intestine	90	\$1,984		
47900		Suture bile duct injury	90	\$2,190		
47999		Bile tract surgery procedure		BR		
48000		Drainage of abdomen	90	\$1,526		
48001		Placement of drain, pancreas	90	\$1,809		
48020		Removal of pancreatic stone	90	\$1,510		
48100		Biopsy of pancreas	90	\$1,076		
48102		Needle biopsy, pancreas	10	\$502		
48105		Resect/debride pancreas		\$5,918		
48120		Removal of pancreas lesion	90	\$1,740		
48140		Partial removal of pancreas	90	\$2,434		
48145		Partial removal of pancreas	90	\$2,687		
48146		Pancreatectomy	90	\$2,841		
48148		Removal of pancreatic duct	90	\$1,722		
48150		Partial removal of pancreas	90	\$4,350		
48152		Pancreatectomy	90	\$4,125		
48153		Pancreatectomy	90	\$4,350		
48154		Pancreatectomy	90	\$4,125		
48155		Removal of pancreas	90	\$3,122		
48160		Pancreas removal, transplant		BR		

LABOR AND EMPLOYMENT

CPT Code	Mod	Description	Global Days	Maximum Allowance	Non-Facility Maximum	Facility Maximum
48400		Injection, intraop add on		\$221		
48500		Surgery of pancreas cyst	90	\$1,573		
48510		Drain pancreatic pseudocyst	90	\$1,547		
48511		Drain pancreatic pseudocyst	0	\$551		
48520		Fuse pancreas cyst and bowel	90	\$1,890		
48540		Fuse pancreas cyst and bowel	90	\$2,201		
48545		Pancreatorrhaphy	90	\$1,706		
48547		Duodenal exclusion	90	\$2,467		
48548		Fuse pancreas and bowel		\$3,448		
48550		Donor pancreatectomy		BR		
48552		Prep donor pancreas/venous		\$488		
48554		Transplantallograft pancreas	90	\$5,322		
48556		Removal, allograft pancreas	90	\$2,648		
48999		Pancreas surgery procedure		BR		
49000		Exploration of abdomen	90	\$1,217		
49002		Reopening of abdomen	90	\$1,179		
49010		Exploration behind abdomen	90	\$1,377		
49020		Drain abdominal abscess	90	\$1,666		
49021		Drain abdominal abscess	0	\$596		
49040		Drain, open, abdom abscess	90	\$1,266		
49041		Drain, percut, abdom abscess	0	\$565		
49060		Drain, open, retroper abscess	90	\$1,324		
49061		Drain, percut, retroper abscess	0	\$531		
49062		Drain to peritoneal cavity	90	\$1,414		
49082		Abd paracentesis			\$337	\$143
49084		Peritoneal lavage		\$204		
49180		Biopsy, abdominal mass	0	\$249		
49204		Exc abd tum over 5 cm		\$3,154		
49205		Exc abd tum over 10 cm		\$3,618		
49215		Excise sacral spine tumor	90	\$2,204		
49220		Multiple surgery, abdomen	90	\$2,017		
49250		Excision of umbilicus	90	\$913		
49255		Removal of omentum	90	\$733		
49320		Diag laparo separate proc	10	\$680		
49321		Laparoscopy, biopsy...	10	\$720		
49322		Laparoscopy, aspiration	10	\$771		
49323		Laparo drain lymphocele	90	\$1,343		
49324		Lap insert tunnel ip cath		\$820		
49325		Lap revision perm ip cath		\$875		
49326		Lap w/omentopexy add-on		\$393		
49327		Lap ins device for rt		\$269		
49329		Laparo proc, abdm/per/oment		BR		
49400		Air injection into abdomen	0	\$224		
49402		Remove foreign body abdomen		\$1,772		
49411		Ins mark abd/pel for rt perq		\$1,143		
49412		Ins device for rt guide open		\$167		
49418		Insert tun ip cath perc		\$3,273		
49419		Insert tun ip cath w/port		\$917		
49421		Insert abdominal drain	90	\$697		
49422		Remove perm cannula/catheter	10	\$756		
49423		Exchange drainage catheter	0	\$185		
49424		Assess cyst, contrast inject	0	\$98		
49425		Insert abdomen-venous drain	90	\$1,486		
49426		Revise abdomen-venous shunt	90	\$1,064		
49427		Injection, abdominal shunt	0	\$101		
49428		Ligation of shunt	10	\$228		
49429		Removal of shunt	10	\$731		
49435		Insert subq exten to ip cath		\$251		
49436		Embedded ip cath exit-site		\$385		
49440		Place gastrostomy tube perc		\$2,176		
49441		Place duod/jej tube perc			\$2,422	\$522
49442		Place cecostomy tube perc			\$1,916	\$443
49446		Change g-tube to g-j perc			\$2,051	\$332
49450		Replace g/c tube perc			\$1,357	\$136
49451		Replace duod/jej tube perc			\$1,483	\$187
49452		Replace g-j tube perc			\$1,823	\$287

Title 40, Part I

CPT Code	Mod	Description	Global Days	Maximum Allowance	Non-Facility Maximum	Facility Maximum
49460		Fix g/colon tube w/device			\$1,528	\$99
49465		Fluoro exam of g/colon tube			\$351	\$62
49491		Rpr hern preemie reduc		\$1,590		
49492		Rpr ing hern premie blocked		\$1,983		
49495		Repair inguinal hernia, init	90	\$830		
49496		Repair inguinal hernia, init	90	\$1,026		
49500		Repair inguinal hernia	90	\$733		
49501		Repair inguinal hernia, init	90	\$948		
49505		Repair inguinal hernia	90	\$823		
49507		Repair, inguinal hernia	90	\$957		
49520		Rerepair inguinal hernia	90	\$1,006		
49521		Repair inguinal hernia, rec	90	\$1,101		
49525		Repair inguinal hernia	90	\$969		
49540		Repair lumbar hernia	90	\$1,008		
49550		Repair femoral hernia	90	\$898		
49553		Repair femoral hernia, init	90	\$919		
49555		Repair femoral hernia	90	\$1,035		
49557		Repair femoral hernia, recur	90	\$1,137		
49560		Repair abdominal hernia	90	\$1,170		
49561		Repair incisional hernia	90	\$1,290		
49565		Rerepair abdominal hernia	90	\$1,228		
49566		Repair incisional hernia	90	\$1,356		
49568		Hernia repair w/mesh..		\$557		
49570		Repair epigastric hernia	90	\$691		
49572		Repair, epigastric hernia	90	\$859		
49580		Repair umbilical hernia	90	\$598		
49582		Repair umbilical hernia	90	\$756		
49585		Repair umbilical hernia	90	\$727		
49587		Repair umbilical hernia	90	\$797		
49590		Repair abdominal hernia	90	\$948		
49600		Repair umbilical lesion	90	\$1,099		
49605		Repair umbilical lesion	90	\$2,284		
49606		Repair umbilical lesion	90	\$1,925		
49610		Repair umbilical lesion	90	\$1,174		
49611		Repair umbilical lesion	90	\$1,263		
49650		Laparo hernia repair initial	90	\$888		
49651		Laparo hernia repair recur	90	\$1,157		
49652		Lap vent/abd hernia repair		\$1,433		
49653		Lap vent/abd hern comp		\$1,790		
49654		Lap inc hernia repair		\$1,627		
49655		Lap inc hern repair comp		\$1,989		
49656		Lap inc hernia repair recur		\$1,767		
49657		Lap inc hern recur comp		\$2,538		
49659		Laparo proc, hernia repair		BR		
49900		Repair of abdominal wall	90	\$634		
49904		Omental flap extra-abdom		\$3,019		
49905		Omental flap		\$763		
49906		Free omental flap, microvasc	90	BR		
49999		Abdomen surgery procedure		BR		
50010		Exploration of kidney	90	\$1,469		
50020		Renal abscess, open drain.	90	\$1,638		
50021		Renal abscess, percut drain	0	\$522		
50040		Drainage of kidney	90	\$1,529		
50045		Exploration of kidney	90	\$1,783		
50060		Removal of kidney stone	90	\$2,227		
50065		Incision of kidney	90	\$2,471		
50070		Incision of kidney	90	\$2,362		
50075		Removal of kidney stone	90	\$3,012		
50080		Removal of kidney stone	90	\$1,935		
50081		Removal of kidney stone	90	\$2,618		
50100		Revise kidney blood vessels	90	\$1,897		
50120		Exploration of kidney	90	\$1,922		
50125		Explore and drain kidney	90	\$1,955		
50130		Removal of kidney stone	90	\$2,136		
50135		Exploration of kidney	90	\$2,607		
50200		Biopsy of kidney	0	\$387		

LABOR AND EMPLOYMENT

CPT Code	Mod	Description	Global Days	Maximum Allowance	Non-Facility Maximum	Facility Maximum
50205		Biopsy of kidney	90	\$1,347		
50220		Removal of kidney	90	\$2,175		
50225		Removal of kidney	90	\$2,630		
50230		Removal of kidney	90	\$2,888		
50234		Removal of kidney & ureter	90	\$2,790		
50236		Removal of kidney & ureter	90	\$3,031		
50240		Partial removal of kidney	90	\$2,686		
50250		Cryoablate renal mass open		\$2,494		
50280		Removal of kidney lesion	90	\$1,886		
50290		Removal of kidney lesion	90	\$1,681		
50300		Removal of donor kidney		BR		
50320		Removal of donor kidney	90	\$2,787		
50327		Prep renal graft/venous		\$448		
50328		Prep renal graft/arterial		\$391		
50329		Prep renal graft/ureteral		\$360		
50340		Removal of kidney	90	\$1,802		
50360		Transplantation of kidney	90	\$4,131		
50365		Transplantation of kidney	90	\$4,752		
50370		Remove transplanted kidney	90	\$1,840		
50380		Reimplantation of kidney	90	\$2,005		
50382		Change ureter stent percut			\$2,473	\$554
50384		Remove ureter stent percut			\$1,993	\$502
50385		Change stent via transureth			\$2,388	\$470
50386		Remove stent via transureth			\$1,555	\$355
50387		Change ext/int ureter stent			\$1,148	\$201
50389		Remove renal tube w/fluoro			\$606	\$110
50390		Drainage of kidney lesion	0	\$360		
50391		Instill rx agnt into mal tub			\$247	\$201
50392		Insert kidney drain	0	\$577		
50393		Insert ureteral tube	0	\$719		
50394		Injection for kidney X-ray	0	\$97		
50395		Create passage to kidney	0	\$621		
50396		Measure kidney pressure	0	\$187		
50398		Change kidney tube	0	\$145		
50400		Revision of kidney/ureter	90	\$2,343		
50405		Revision of kidney/ureter	90	\$2,936		
50500		Repair of kidney wound	90	\$2,292		
50520		Close kidney-skin fistula	90	\$1,967		
50525		Repair renal-abdomen fistula	90	\$2,491		
50526		Repair renal-abdomen fistula	90	\$2,256		
50540		Revision of horseshoe kidney	90	\$2,414		
50541		Laparo ablate renal cyst	90	BR		
50542		Laparo ablate renal mass		\$2,386		
50543		Laparo partial nephrectomy		\$3,048		
50544		Laparoscopy, pyeloplasty	90	\$2,552		
50545		Laparo radical nephrectomy		\$2,747		
50546		Laparoscopic nephrectomy	90	\$2,460		
50547		Laparo removal donor kidney	90	\$3,321		
50548		Laparo-asst remove k/ureter	90	\$2,756		
50549		Laparoscope proc, renal		BR		
50551		Kidney endoscopy	0	\$566		
50553		Kidney endoscopy	0	\$554		
50555		Kidney endoscopy & biopsy	0	\$827		
50557		Kidney endoscopy & treatment	0	\$837		
50561		Kidney endoscopy & treatment	0	\$935		
50562		Renal scope w/tumor resect		\$1,190		
50570		Kidney endoscopy	0	\$789		
50572		Kidney endoscopy	0	\$1,300		
50574		Kidney endoscopy & biopsy	0	\$1,327		
50575		Kidney endoscopy	0	\$1,762		
50576		Kidney endoscopy & treatment	0	\$1,448		
50580		Kidney endoscopy & treatment	0	\$1,118		
50590		Fragmenting of kidney stone	90	\$1,466		
50592		Perc rf ablate renal tumor			\$6,199	\$732
50593		Perc cryo ablate renal tum			\$9,224	\$978
50600		Exploration of ureter	90	\$1,804		

Title 40, Part I

CPT Code	Mod	Description	Global Days	Maximum Allowance	Non-Facility Maximum	Facility Maximum
50605		Insert ureteral support	90	\$1,495		
50610		Removal of ureter stone	90	\$1,968		
50620		Removal of ureter stone	90	\$1,899		
50630		Removal of ureter stone	90	\$1,976		
50650		Removal of ureter	90	\$2,098		
50660		Removal of ureter	90	\$2,299		
50684		Injection for ureter X-ray	0	\$93		
50686		Measure ureter pressure	0	\$136		
50688		Change of ureter tube	10	\$111		
50690		Injection for ureter X-ray	0	\$107		
50700		Revision of ureter	90	\$1,979		
50715		Release of ureter	90	\$2,148		
50722		Release of ureter	90	\$1,939		
50725		Release/revise ureter	90	\$2,189		
50727		Revise ureter	90	\$952		
50728		Revise ureter	90	\$1,402		
50740		Fusion of ureter & kidney	90	\$2,267		
50750		Fusion of ureter & kidney	90	\$2,367		
50760		Fusion of ureters	90	\$2,271		
50770		Splicing of ureters	90	\$2,471		
50780		Reimplant ureter in bladder	90	\$2,291		
50782		Reimplant ureter in bladder	90	\$2,369		
50783		Reimplant ureter in bladder	90	\$2,436		
50785		Reimplant ureter in bladder	90	\$2,574		
50800		Implant ureter in bowel	90	\$2,073		
50810		Fusion of ureter & bowel	90	\$2,298		
50815		Urine shunt to bowel	90	\$2,877		
50820		Construct bowel bladder	90	\$2,946		
50825		Construct bowel bladder	90	\$4,252		
50830		Revise urine flow	90	\$3,716		
50840		Replace ureter by bowel	90	\$2,323		
50845		Appendico-vesicostomy	90	\$2,460		
50860		Transplant ureter to skin	90	\$1,846		
50900		Repair of ureter	90	\$1,678		
50920		Closure ureter/skin fistula	90	\$1,680		
50930		Closure ureter/bowel fistula	90	\$2,218		
50940		Release of ureter	90	\$1,722		
50945		Laparoscopy ureterolithotomy	90	\$1,990		
50947		Laparo new ureter/bladder		\$2,829		
50948		Laparo new ureter/bladder		\$2,608		
50951		Endoscopy of ureter	0	\$544		
50953		Endoscopy of ureter	0	\$571		
50955		Ureter endoscopy & biopsy	0	\$677		
50957		Ureter endoscopy & treatment	0	\$676		
50961		Ureter endoscopy & treatment	0	\$633		
50970		Ureter endoscopy	0	\$909		
50972		Ureter endoscopy & catheter	0	\$609		
50974		Ureter endoscopy & biopsy	0	\$1,192		
50976		Ureter endoscopy & treatment	0	\$1,138		
50980		Ureter endoscopy & treatment	0	\$728		
51020		Incise & treat bladder	90	\$964		
51030		Incise & treat bladder	90	\$779		
51040		Incise & drain bladder	90	\$803		
51045		Incise bladder, drain ureter	90	\$815		
51050		Removal of bladder stone	90	\$982		
51060		Removal of ureter stone	90	\$1,443		
51065		Removal of ureter stone	90	\$1,122		
51080		Drainage of bladder abscess	90	\$791		
51100		Drain bladder by needle			\$124	\$79
51101		Drain bladder by trocar/cath			\$255	\$108
51102		Drain bl w/cath insertion			\$458	\$295
51500		Removal of bladder cyst	90	\$1,247		
51520		Removal of bladder lesion	90	\$1,281		
51525		Removal of bladder lesion	90	\$1,735		
51530		Removal of bladder lesion	90	\$1,529		
51535		Repair of ureter lesion	90	\$1,440		

LABOR AND EMPLOYMENT

CPT Code	Mod	Description	Global Days	Maximum Allowance	Non-Facility Maximum	Facility Maximum
51550		Partial removal of bladder	90	\$1,856		
51555		Partial removal of bladder	90	\$2,348		
51565		Revise bladder & ureter(s)	90	\$2,656		
51570		Removal of bladder	90	\$2,792		
51575		Removal of bladder & nodes	90	\$3,755		
51580		Remove bladder; revise tract	90	\$3,552		
51585		Removal of bladder & nodes	90	\$4,231		
51590		Remove bladder; revise tract	90	\$4,056		
51595		Remove bladder; revise tract	90	\$5,054		
51596		Remove bladder, create pouch	90	\$5,281		
51597		Removal of pelvic structures	90	\$4,970		
51600		Injection for bladder X-ray	0	\$84		
51605		Preparation for bladder xray	0	\$103		
51610		Injection for bladder X-ray	0	\$133		
51700		Irrigation of bladder	0	\$80		
51701		Insert bladder catheter			\$110	\$56
51705		Change of bladder tube	10	\$100		
51715		Endoscopic injection/implant	0	\$472		
51720		Treatment of bladder lesion	0	\$175		
51725		Simple cystometrogram	0	\$187		
51725	26	Simple cystometrogram	0	\$157		
51725	TC	Simple cystometrogram	0	\$30		
51726		Complex cystometrogram	0	\$222		
51726	26	Complex cystometrogram	0	\$185		
51726	TC	Complex cystometrogram	0	\$38		
51727		Cystometrogram w/up	0	\$425		
51728	26	Cystometrogram w/vp	0	\$217		
51728	TC	Cystometrogram w/vp	0	\$431		
51728		Cystometrogram w/vp	0	\$648		
51729	26	Cystometrogram w/vp&up	0	\$264		
51729	TC	Cystometrogram w/vp&up	0	\$442		
51729		Cystometrogram w/vp&up	0	\$707		
51736		Urine flow measurement	0	\$91		
51736	26	Urine flow measurement	0	\$80		
51736	TC	Urine flow measurement	0	\$12		
51741		Electro-uroflowmetry, first	0	\$155		
51741	26	Electro-uroflowmetry, first	0	\$139		
51741	TC	Electro-uroflowmetry, first	0	\$17		
51784		Anal/urinary muscle study	0	\$188		
51784	26	Anal/urinary muscle study	0	\$158		
51784	TC	Anal/urinary muscle study	0	\$30		
51785		Anal/urinary muscle study	0	\$190		
51785	26	Anal/urinary muscle study	0	\$160		
51785	TC	Anal/urinary muscle study	0	\$31		
51792		Urinary reflex study	0	\$229		
51792	26	Urinary reflex study	0	\$124		
51792	TC	Urinary reflex study	0	\$105		
51797		Intraabdominal pressure test	0	\$189		
51797	26	Intraabdominal pressure test	0	\$154		
51797	TC	Intraabdominal pressure test	0	\$35		
51800		Revision of bladder/urethra	90	\$2,110		
51820		Revision of urinary tract	90	\$1,797		
51840		Attach bladder/urethra	90	\$1,447		
51841		Attach bladder/urethra	90	\$1,741		
51845		Repair bladder neck	90	\$1,477		
51860		Repair of bladder wound	90	\$1,394		
51865		Repair of bladder wound	90	\$1,856		
51880		Repair of bladder opening	90	\$899		
51900		Repair bladder/vagina lesion	90	\$1,751		
51920		Close bladder-uterus fistula	90	\$1,332		
51925		Hysterectomy/bladder repair	90	\$1,876		
51940		Correction of bladder defect	90	\$3,268		
51960		Revision of bladder & bowel	90	\$3,174		
51980		Construct bladder opening	90	\$1,320		
51990		Laparo urethral suspension	90	\$1,574		
51992		Laparo sling operation	90	\$1,788		



Title 40, Part I

CPT Code	Mod	Description	Global Days	Maximum Allowance	Non-Facility Maximum	Facility Maximum
52000		Cystoscopy	0	\$246		
52001		Cystoscopy removal of clots			\$743	\$582
52005		Cystoscopy & ureter catheter	0	\$339		
52007		Cystoscopy and biopsy	0	\$433		
52010		Cystoscopy & duct catheter	0	\$362		
52204		Cystoscopy	0	\$354		
52214		Cystoscopy and treatment	0	\$481		
52224		Cystoscopy and treatment	0	\$448		
52234		Cystoscopy and treatment	0	\$693		
52235		Cystoscopy and treatment	0	\$980		
52240		Cystoscopy and treatment	0	\$1,516		
52250		Cystoscopy & radiotracer	0	\$542		
52260		Cystoscopy & treatment	0	\$442		
52265		Cystoscopy & treatment	0	\$313		
52270		Cystoscopy & revise urethra	0	\$542		
52275		Cystoscopy & revise urethra	0	\$599		
52276		Cystoscopy and treatment	0	\$634		
52277		Cystoscopy and treatment	0	\$812		
52281		Cystoscopy and treatment	0	\$394		
52282		Cystoscopy, implant stent	0	\$845		
52283		Cystoscopy and treatment	0	\$383		
52285		Cystoscopy and treatment	0	\$485		
52290		Cystoscopy and treatment	0	\$508		
52300		Cystoscopy and treatment	0	\$623		
52301		Cystoscopy and treatment	0	\$639		
52305		Cystoscopy and treatment	0	\$649		
52310		Cystoscopy and treatment	0	\$432		
52315		Cystoscopy and treatment	0	\$686		
52317		Remove bladder stone..	0	\$1,205		
52318		Remove bladder stone	0	\$1,263		
52320		Cystoscopy and treatment	0	\$710		
52325		Cystoscopy, stone removal	0	\$981		
52327		Cystoscopy, inject material	0	\$647		
52330		Cystoscopy and treatment	0	\$628		
52332		Cystoscopy and treatment	0	\$451		
52334		Create passage to kidney	0	\$602		
52341		Cysto w/ureter stricture tx		\$592		
52343		Cysto w/renal stricture tx		\$716		
52344		Cysto/uretero stricture tx		\$778		
52345		Cysto/uretero w/up stricture		\$829		
52346		Cystouretero w/renal strict		\$938		
52351		Cystouretero & or pyeloscope		\$643		
52352		Cystouretero w/stone remove		\$755		
52353		Cystouretero w/lithotripsy		\$867		
52354		Cystouretero w/biopsy		\$803		
52355		Cystouretero w/excise tumor		\$955		
52400		Cystouretero w/congen repr		\$977		
52402		Cystourethro cut ejacul duct		\$546		
52450		Incision of prostate	90	\$888		
52500		Revision of bladder neck	90	\$1,132		
52601		Prostatectomy (TURP)..	90	\$1,724		
52630		Remove prostate regrowth	90	\$1,269		
52640		Relieve bladder contracture	90	\$927		
52647		Laser surgery of prostate	90	\$1,432		
52648		Laser surgery of prostate	90	\$1,518		
52649		Prostate laser enucleation		\$1,666		
52700		Drainage of prostate abscess	90	\$705		
53000		Incision of urethra	10	\$279		
53010		Incision of urethra	90	\$489		
53020		Incision of urethra	0	\$190		
53025		Incision of urethra	0	\$143		
53040		Drainage of urethra abscess	90	\$570		
53060		Drainage of urethra abscess	10	\$224		
53080		Drainage of urinary leakage	90	\$729		
53085		Drainage of urinary leakage	90	\$1,213		
53200		Biopsy of urethra	0	\$270		

LABOR AND EMPLOYMENT

CPT Code	Mod	Description	Global Days	Maximum Allowance	Non-Facility Maximum	Facility Maximum
53210		Removal of urethra	90	\$1,347		
53215		Removal of urethra	90	\$1,809		
53220		Treatment of urethra lesion	90	\$838		
53230		Removal of urethra lesion	90	\$1,258		
53235		Removal of urethra lesion	90	\$1,071		
53240		Surgery for urethra pouch	90	\$766		
53250		Removal of urethra gland	90	\$717		
53260		Treatment of urethra lesion	10	\$298		
53265		Treatment of urethra lesion	10	\$366		
53270		Removal of urethra gland	10	\$280		
53275		Repair of urethra defect	10	\$495		
53400		Revise urethra, 1st stage	90	\$1,417		
53405		Revise urethra, 2nd stage	90	\$1,790		
53410		Reconstruction of urethra	90	\$1,769		
53415		Reconstruction of urethra	90	\$2,231		
53420		Reconstruct urethra, stage 1	90	\$1,785		
53425		Reconstruct urethra, stage 2	90	\$1,792		
53430		Reconstruction of urethra	90	\$1,661		
53431		Reconstruct urethra/bladder		\$2,359		
53440		Correct bladder function	90	\$1,843		
53442		Remove perineal prosthesis	90	\$1,004		
53444		Insert tandem cuff		\$1,620		
53445		Correct urine flow control	90	\$2,395		
53446		Remove uro sphincter		\$1,312		
53447		Remove artificial sphincter	90	\$1,587		
53448		Remov/reple ur sphinctr comp		\$2,616		
53449		Correct artificial sphincter	90	\$1,302		
53450		Revision of urethra	90	\$618		
53460		Revision of urethra	90	\$665		
53500		Urethrls transvag w/ scope		\$1,545		
53502		Repair of urethra injury	90	\$903		
53505		Repair of urethra injury	90	\$914		
53510		Repair of urethra injury	90	\$1,219		
53515		Repair of urethra injury	90	\$1,601		
53520		Repair of urethra defect	90	\$1,039		
53600		Dilate urethra stricture	0	\$111		
53601		Dilate urethra stricture	0	\$92		
53605		Dilate urethra stricture	0	\$127		
53620		Dilate urethra stricture	0	\$152		
53621		Dilate urethra stricture	0	\$125		
53660		Dilation of urethra	0	\$73		
53661		Dilation of urethra	0	\$71		
53665		Dilation of urethra	0	\$82		
53850		Prostatic microwave thermotx	90	\$1,185		
53852		Prostatic rf thermotx	90	\$1,236		
53855		Insert prost urethral stent			\$1,553	\$167
53860		Transurethral rf treatment			\$3,129	\$480
53899		Urology surgery procedure		BR		
54000		Slitting of prepuce	10	\$156		
54001		Slitting of prepuce	10	\$217		
54015		Drain penis lesion	10	\$431		
54050		Destruction, penis lesion(s)	10	\$113		
54055		Destruction, penis lesion(s)	10	\$132		
54056		Cryosurgery, penis lesion(s)	10	\$125		
54057		Laser surg, penis lesion(s)	10	\$228		
54060		Excision of penis lesion(s)	10	\$224		
54065		Destruction, penis lesion(s)	10	\$361		
54100		Biopsy of penis.....	0	\$224		
54105		Biopsy of penis	10	\$324		
54110		Treatment of penis lesion	90	\$1,155		
54111		Treat penis lesion, graft	90	\$1,641		
54112		Treat penis lesion, graft	90	\$1,920		
54115		Treatment of penis lesion	90	\$729		
54120		Partial removal of penis	90	\$1,156		
54125		Removal of penis	90	\$1,807		
54130		Remove penis & nodes	90	\$2,470		

Title 40, Part I

CPT Code	Mod	Description	Global Days	Maximum Allowance	Non-Facility Maximum	Facility Maximum
54135		Remove penis & nodes	90	\$3,150		
54150		Circumcision	10	\$168		
54160		Circumcision	10	\$305		
54161		Circumcision	10	\$398		
54162		Lysis penil circumic lesion			\$518	\$403
54163		Repair of circumcision		\$446		
54164		Frenulotomy of penis		\$394		
54200		Treatment of penis lesion	10	\$96		
54205		Treatment of penis lesion	90	\$908		
54220		Treatment of penis lesion	0	\$296		
54230		Prepare penis study	0	\$199		
54231		Dynamic cavernosometry	0	\$313		
54235		Penile injection	0	\$117		
54240		Penis study	0	\$172		
54240	26	Penis study	0	\$133		
54240	TC	Penis study	0	\$39		
54250		Penis study	0	\$220		
54250	26	Penis study	0	\$196		
54250	TC	Penis study	0	\$24		
54300		Revision of penis	90	\$1,260		
54304		Revision of penis	90	\$1,536		
54308		Reconstruction of urethra	90	\$1,286		
54312		Reconstruction of urethra	90	\$1,659		
54316		Reconstruction of urethra	90	\$2,013		
54318		Reconstruction of urethra	90	\$1,353		
54322		Reconstruction of urethra	90	\$1,465		
54324		Reconstruction of urethra	90	\$1,948		
54326		Reconstruction of urethra	90	\$1,865		
54328		Revise penis, urethra	90	\$1,894		
54332		Revise penis, urethra	90	\$2,111		
54336		Revise penis, urethra	90	\$2,771		
54340		Secondary urethral surgery	90	\$1,078		
54344		Secondary urethral surgery	90	\$2,331		
54348		Secondary urethral surgery	90	\$2,062		
54352		Reconstruct urethra, penis	90	\$2,939		
54360		Penis plastic surgery	90	\$1,356		
54380		Repair penis	90	\$1,611		
54385		Repair penis	90	\$1,848		
54390		Repair penis and bladder	90	\$2,557		
54400		Insert semi-rigid prosthesis	90	\$1,544		
54401		Insert self-contd prosthesis	90	\$1,925		
54405		Insert multi-comp prosthesis	90	\$2,411		
54406		Remove multi-comp penis pros		\$1,492		
54408		Repair multi-comp penis pros		\$1,615		
54410		Remove/replace penis prosth		\$1,756		
54411		Remov/replc penis pros comp		\$2,095		
54415		Remove self-contd penis pros		\$1,080		
54416		Remv/repl penis contain pros		\$1,452		
54417		Remv/replc penis pros compl		\$1,837		
54420		Revision of penis	90	\$1,371		
54430		Revision of penis	90	\$1,221		
54435		Revision of penis	90	\$720		
54440		Repair of penis	90	BR		
54450		Preputial stretching	0	\$133		
54500		Biopsy of testis	0	\$127		
54505		Biopsy of testis	10	\$389		
54512		Excise lesion testis		\$1,106		
54520		Removal of testis	90	\$762		
54522		Orchiectomy partial		\$1,206		
54530		Removal of testis	90	\$1,142		
54535		Extensive testis surgery	90	\$1,486		
54550		Exploration for testis	90	\$936		
54560		Exploration for testis	90	\$1,310		
54600		Reduce testis torsion	90	\$828		
54620		Suspension of testis	10	\$591		
54640		Suspension of testis	90	\$1,082		

LABOR AND EMPLOYMENT

CPT Code	Mod	Description	Global Days	Maximum Allowance	Non-Facility Maximum	Facility Maximum
54650		Orchiopexy (fowler-stephens)	90	\$1,392		
54660		Revision of testis	90	\$605		
54670		Repair testis injury	90	\$827		
54680		Relocation of testis(es)	90	\$1,453		
54690		Laparoscopy, orchiectomy	90	\$1,532		
54692		Laparoscopy, orchiopexy	90	\$1,551		
54699		Laparoscope proc, testis		BR		
54700		Drainage of scrotum	10	\$311		
54800		Biopsy of epididymis	0	\$318		
54830		Remove epididymis lesion	90	\$635		
54840		Remove epididymis lesion	90	\$732		
54860		Removal of epididymis	90	\$828		
54861		Removal of epididymis	90	\$1,172		
54865		Explore epididymis		\$732		
54900		Fusion of spermatic ducts	90	\$1,588		
54901		Fusion of spermatic ducts	90	\$2,180		
55000		Drainage of hydrocele	0	\$133		
55040		Removal of hydrocele	90	\$749		
55041		Removal of hydroceles	90	\$1,109		
55060		Repair of hydrocele	90	\$698		
55100		Drainage of scrotum abscess	10	\$194		
55110		Explore scrotum	90	\$647		
55120		Removal of scrotum lesion	90	\$480		
55150		Removal of scrotum	90	\$895		
55175		Revision of scrotum	90	\$701		
55180		Revision of scrotum	90	\$1,255		
55200		Incision of sperm duct	90	\$447		
55250		Removal of sperm duct(s)	90	\$434		
55300		Preparation, sperm duct X-ray	0	\$460		
55400		Repair of sperm duct	90	\$1,092		
55450		Ligation of sperm duct	10	\$484		
55500		Removal of hydrocele	90	\$716		
55520		Removal of sperm cord lesion	90	\$662		
55530		Revise spermatic cord veins	90	\$797		
55535		Revise spermatic cord veins	90	\$786		
55540		Revise hernia & sperm veins	90	\$899		
55550		Laparo ligate spermatic vein	90	\$874		
55559		Laparo proc, spermatic cord		BR		
55600		Incise sperm duct pouch	90	\$775		
55605		Incise sperm duct pouch	90	\$976		
55650		Remove sperm duct pouch	90	\$1,363		
55680		Remove sperm pouch lesion	90	\$682		
55700		Biopsy of prostate	0	\$229		
55705		Biopsy of prostate	10	\$575		
55706		Prostate saturation sampling		\$749		
55720		Drainage of prostate abscess	90	\$808		
55725		Drainage of prostate abscess	90	\$982		
55801		Removal of prostate	90	\$2,156		
55810		Extensive prostate surgery	90	\$2,893		
55812		Extensive prostate surgery	90	\$3,205		
55815		Extensive prostate surgery	90	\$3,971		
55821		Removal of prostate	90	\$1,977		
55831		Removal of prostate	90	\$2,145		
55840		Extensive prostate surgery	90	\$2,791		
55842		Extensive prostate surgery	90	\$3,096		
55845		Extensive prostate surgery	90	\$3,842		
55860		Surgical exposure, prostate	90	\$1,498		
55862		Extensive prostate surgery	90	\$2,122		
55865		Extensive prostate surgery	90	\$3,437		
55866		Laparo radical prostatectomy		\$3,553		
55870		Electroejaculation	0	\$357		
55873		Cryoablate prostate			\$13,774	\$1,548
55875		Transperi needle place pros		\$1,556		
55876		Place rt device/marker pros			\$270	\$202
55899		Genital surgery procedure		BR		
55920		Place needles pelvic for rt		\$894		

Title 40, Part I

CPT Code	Mod	Description	Global Days	Maximum Allowance	Non-Facility Maximum	Facility Maximum
55970		Sex transformation, m to f		BR		
55980		Sex transformation, f to m		BR		
56405		I & d of vulva/perineum	10	\$164		
56420		Drainage of gland abscess	10	\$161		
56440		Surgery for vulva lesion	10	\$421		
56441		Lysis of labial lesion(s)	10	\$274		
56442		Hymenotomy		\$101		
56501		Destruction, vulva lesion(s)	10	\$152		
56515		Destruction, vulva lesion(s)	10	\$374		
56605		Biopsy of vulva/perineum	0	\$120		
56606		Biopsy of vulva/ perineum		\$87		
56620		Partial removal of vulva	90	\$1,031		
56625		Complete removal of vulva	90	\$1,351		
56630		Extensive vulva surgery	90	\$2,016		
56631		Extensive vulva surgery	90	\$2,749		
56632		Extensive vulva surgery	90	\$3,008		
56633		Extensive vulva surgery	90	\$2,247		
56634		Extensive vulva surgery	90	\$2,994		
56637		Extensive vulva surgery	90	\$3,154		
56640		Extensive vulva surgery	90	\$3,143		
56700		Partial removal of hymen	10	\$325		
56720		Incision of hymen	0	\$91		
56740		Remove vagina gland lesion	10	\$497		
56800		Repair of vagina	10	\$511		
56805		Repair clitoris.....	90	\$2,203		
56810		Repair of perineum	10	\$503		
56820		Exam of vulva w/scope			\$231	\$179
56821		Exam/biopsy of vulva w/scope			\$305	\$240
57000		Exploration of vagina	10	\$375		
57010		Drainage of pelvic abscess	90	\$607		
57020		Drainage of pelvic fluid	0	\$163		
57022		I & d vaginal hematoma pp		\$355		
57023		I & d vag hematoma non-ob		\$657		
57061		Destruction vagina lesion(s)	10	\$155		
57065		Destruction vagina lesion(s)	10	\$467		
57100		Biopsy of vagina	0	\$122		
57105		Biopsy of vagina	10	\$251		
57106		Remove vagina wall, partial	90	\$680		
57107		Remove vagina tissue, part.	90	\$2,278		
57109		Vaginectomy partial w/nodes	90	\$2,800		
57110		Remove vagina wall, complete	90	\$1,666		
57111		Remove vagina tissue, complete	90	\$2,775		
57112		Vaginectomy w/nodes, complete	90	\$2,954		
57120		Closure of vagina	90	\$1,078		
57130		Remove vagina lesion	10	\$395		
57135		Remove vagina lesion	10	\$350		
57150		Treat vagina infection	0	\$83		
57155		Insert uteri tandems/ovoids		\$890		
57156		Ins vag brachytx device			\$391	\$291
57160		Insert pessary/other device	0	\$100		
57170		Fitting of diaphragm/cap	0	\$91		
57180		Treat vaginal bleeding	10	\$156		
57200		Repair of vagina	90	\$495		
57210		Repair vagina/perineum	90	\$613		
57220		Revision of urethra	90	\$645		
57230		Repair of urethral lesion	90	\$677		
57240		Repair bladder & vagina	90	\$997		
57250		Repair rectum & vagina	90	\$975		
57260		Repair of vagina	90	\$1,283		
57265		Extensive repair of vagina	90	\$1,337		
57267		Insert mesh/pelvic flr addon		\$539		
57268		Repair of bowel bulge	90	\$1,039		
57270		Repair of bowel pouch	90	\$1,107		
57280		Suspension of vagina	90	\$1,326		
57282		Repair of vaginal prolapse	90	\$1,322		
57283		Colpopexy intraperitoneal		\$1,455		

LABOR AND EMPLOYMENT

CPT Code	Mod	Description	Global Days	Maximum Allowance	Non-Facility Maximum	Facility Maximum
57284		Repair paravaginal defect.	90	\$1,535		
57285		Repair paravag defect vag		\$1,415		
57287		Revise/remove sling repair		\$1,411		
57288		Repair bladder defect	90	\$1,729		
57289		Repair bladder & vagina	90	\$1,126		
57291		Construction of vagina	90	\$991		
57292		Construct vagina with graft	90	\$1,435		
57295		Revise vag graft via vagina		\$1,003		
57296		Revise vag graft open abd		\$2,011		
57300		Repair rectum-vagina fistula	90	\$1,160		
57305		Repair rectum-vagina fistula	90	\$1,260		
57307		Fistula repair & colostomy	90	\$1,235		
57308		Fistula repair, transperine	90	\$1,264		
57310		Repair urethrovaginal lesion	90	\$773		
57311		Repair urethrovaginal lesion	90	\$936		
57320		Repair bladder-vagina lesion	90	\$1,279		
57330		Repair bladder-vagina lesion	90	\$1,470		
57335		Repair vagina.....	90	\$1,899		
57400		Dilation of vagina	0	\$87		
57410		Pelvic examination	0	\$71		
57415		Removal vaginal foreign body	10	\$94		
57420		Exam of vagina w/scope			\$241	\$189
57421		Exam/biopsy of vag w/scope			\$324	\$257
57423		Repair paravag defect lap		\$1,938		
57425		Laparoscopy surg colpoxey		\$2,045		
57426		Revise prosth vag graft lap		\$1,790		
57452		Examination of vagina	0	\$126		
57454		Vagina examination & biopsy	0	\$194		
57455		Biopsy of cervix w/scope		\$299		
57456		Endocerv curettage w/scope			\$280	\$217
57460		Cervix excision.....	0	\$371		
57461		Conz of cervix w/scope leep			\$664	\$395
57500		Biopsy of cervix	0	\$118		
57505		Endocervical curettage	10	\$131		
57510		Cauterization of cervix	10	\$175		
57511		Cryocautery of cervix	10	\$203		
57513		Laser surgery of cervix	10	\$376		
57520		Conization of cervix..	90	\$585		
57522		Conization of cervix	90	\$521		
57530		Removal of cervix	90	\$624		
57531		Removal of cervix, radical	90	\$3,399		
57540		Removal of residual cervix	90	\$1,010		
57545		Remove cervix, repair pelvis	90	\$866		
57550		Removal of residual cervix	90	\$935		
57555		Remove cervix, repair vagina	90	\$1,445		
57556		Remove cervix, repair bowel	90	\$1,340		
57558		D&c of cervical stump			\$260	\$238
57700		Revision of cervix	90	\$427		
57720		Revision of cervix	90	\$505		
57800		Dilation of cervical canal	0	\$96		
57820		D&c of residual cervix	10	\$308		
58100		Biopsy of uterus lining	0	\$113		
58110		Bx done w/colposcopy add-on			\$100	\$86
58120		Dilation and curettage (d&c)	10	\$405		
58140		Removal of uterus lesion	90	\$1,249		
58145		Removal of uterus lesion	90	\$1,214		
58146		Myomectomy abdom complex		\$2,444		
58150		Total hysterectomy	90	\$1,745		
58152		Total hysterectomy....	90	\$2,007		
58180		Partial hysterectomy	90	\$1,482		
58200		Extensive hysterectomy	90	\$2,557		
58210		Extensive hysterectomy	90	\$3,229		
58240		Removal of pelvis contents	90	\$4,507		
58260		Vaginal hysterectomy	90	\$1,617		
58262		Vaginal hysterectomy	90	\$1,736		
58263		Vaginal hysterectomy	90	\$1,897		

Title 40, Part I

CPT Code	Mod	Description	Global Days	Maximum Allowance	Non-Facility Maximum	Facility Maximum
58267		Hysterectomy & vagina repair	90	\$1,978		
58270		Hysterectomy & vagina repair	90	\$1,779		
58275		Hysterectomy, revise vagina	90	\$1,935		
58280		Hysterectomy, revise vagina	90	\$1,923		
58285		Extensive hysterectomy	90	\$2,247		
58290		Vag hyst complex	90	\$2,434		
58291		Vag hyst incl t/o complex	90	\$2,637		
58292		Vag hyst t/o & repair compl	90	\$2,785		
58294		Vag hyst w/enterocele compl	90	\$2,582		
58300		Insert intrauterine device	0	\$136		
58301		Remove intrauterine device	0	\$90		
58290		Vag hyst complex	90	\$2,434		
58321		Artificial insemination	0	\$126		
58322		Artificial insemination	0	\$139		
58323		Sperm washing	0	\$26		
58340		Catheter for hysteroigraphy	0	\$332		
58345		Reopen fallopian tube	10	\$602		
58346		Insert heyman uteri capsule	90	\$937		
58350		Reopen fallopian tube	10	\$150		
58353		Endometr ablate thermal	10		\$2,065	\$459
58356		Endometrial cryoablation	10		\$3,878	\$727
58400		Suspension of uterus	90	\$882		
58410		Suspension of uterus	90	\$931		
58520		Repair of ruptured uterus	90	\$820		
58540		Revision of uterus	90	\$1,143		
58541		Lsh uterus 250 g or less		\$1,828		
58542		Lsh w/t/o ut 250 g or less		\$2,042		
58543		Lsh uterus above 250 g		\$2,076		
58544		Lsh w/t/o uterus above 250 g		\$2,250		
58545		Laparoscopic myomectomy		\$1,893		
58546		Laparo-myomectomy complex		\$2,387		
58548		Lap radical hyst		\$3,841		
58550		Laparo-assst vag hysterectomy	10	\$1,867		
58552		Laparo-vag hyst incl t/o		\$2,076		
58553		Laparo-vag hyst complex		\$2,403		
58554		Laparo-vag hyst w/t/o compl		\$2,781		
58555		Hysteroscopy, dx, sep proc	0	\$633		
58558		Hysteroscopy, biopsy..	0		\$823	\$559
58559		Hysteroscopy, lysis...	0	\$727		
58560		Hysteroscopy, resect septum	0	\$820		
58561		Hysteroscopy, remove myoma	0	\$1,160		
58562		Hysteroscopy, remove fb	0		\$853	\$607
58563		Hysteroscopy, ablation	0		\$3,409	\$719
58565		Hysteroscopy sterilization			\$3,854	\$908
58570		Tlh uterus 250 g or less		\$1,966		
58571		Tlh w/t/o 250 g or less		\$2,191		
58572		Tlh uterus over 250 g		\$2,452		
58573		Tlh w/t/o uterus over 250 g		\$2,807		
58578		Laparo proc, uterus...		BR		
58579		Hysteroscope procedure		BR		
58600		Division of fallopian tube	90	\$800		
58605		Division of fallopian tube	90	\$629		
58611		Ligate oviduct(s) add- on		\$84		
58615		Occlude fallopian tube(s)	10	\$503		
58660		Laparoscopy, lysis....	90	\$1,421		
58661		Laparoscopy, remove adnexa	10	\$1,362		
58662		Laparoscopy, excise lesions	90	\$1,491		
58670		Laparoscopy, tubal cautery	90	\$772		
58671		Laparoscopy, tubal block.	90	\$772		
58672		Laparoscopy, fimbrioplasty	90	\$1,558		
58673		Laparoscopy, salpingostomy	90	\$1,692		
58679		Laparo proc, oviduct- ovary		BR		
58700		Removal of fallopian tube	90	\$960		
58720		Removal of ovary/tube(s)	90	\$1,085		
58740		Revise fallopian tube(s)	90	\$1,057		
58750		Repair oviduct(s)	90	\$1,175		

LABOR AND EMPLOYMENT

CPT Code	Mod	Description	Global Days	Maximum Allowance	Non-Facility Maximum	Facility Maximum
58752		Revise ovarian tube(s)	90	\$1,105		
58760		Remove tubal obstruction	90	\$953		
58770		Create new tubal opening	90	\$945		
58800		Drainage of ovarian cyst(s)	90	\$495		
58805		Drainage of ovarian cyst(s)	90	\$934		
58820		Drain ovary abscess, open	90	\$530		
58822		Drainage of ovarian abscess	90	\$747		
58823		Drain pelvic abscess, percut	0	\$441		
58825		Transposition, ovary(s)	90	\$749		
58900		Biopsy of ovary(s)	90	\$832		
58920		Partial removal of ovary(s)	90	\$1,025		
58925		Removal of ovarian cyst(s)	90	\$1,015		
58940		Removal of ovary(s)	90	\$1,016		
58943		Removal of ovary(s)	90	\$2,281		
58950		Resect ovarian malignancy	90	\$1,963		
58951		Resect ovarian malignancy	90	\$3,016		
58952		Resect ovarian malignancy	90	\$3,071		
58953		Tah rad dissect for debulk		\$4,122		
58954		Tah rad debulk/lymph remove		\$4,467		
58956		Bso omentectomy w/tah		\$2,813		
58957		Resect recurrent gyn mal		\$3,222		
58958		Resect recur gyn mal w/lym		\$3,541		
58960		Exploration of abdomen	90	\$1,845		
58970		Retrieval of oocyte	0	\$447		
58974		Transfer of embryo....	0	BR		
58976		Transfer of embryo....	0	\$494		
58999		Genital surgery procedure		BR		
59000		Amniocentesis	0	\$173		
59001		Amniocentesis therapeutic		\$382		
59012		Fetal cord puncture, prenatal	0	\$452		
59015		Chorion biopsy	0	\$248		
59020		Fetal contract stress test	0	\$164		
59020	26	Fetal contract stress test	0	\$122		
59020	TC	Fetal contract stress test	0	\$43		
59025		Fetal non-stress test	0	\$89		
59025	26	Fetal non-stress test	0	\$71		
59025	TC	Fetal non-stress test	0	\$19		
59030		Fetal scalp blood sample	0	\$268		
59050		Fetal monitor w/report		\$122		
59051		Fetal monitor/interpret only		\$119		
59070		Transabdom amnioinfus w/us			\$855	\$656
59072		Umbilical cord occlud w/us		\$1,098		
59074		Fetal fluid drainage w/us			\$894	\$673
59076		Fetal shunt placement w/us		\$1,098		
59100		Remove uterus lesion	90	\$784		
59120		Treat ectopic pregnancy	90	\$1,167		
59121		Treat ectopic pregnancy	90	\$952		
59130		Treat ectopic pregnancy	90	\$1,030		
59135		Treat ectopic pregnancy	90	\$1,699		
59136		Treat ectopic pregnancy	90	\$1,158		
59140		Treat ectopic pregnancy	90	\$711		
59150		Treat ectopic pregnancy	90	\$844		
59151		Treat ectopic pregnancy	90	\$1,168		
59160		D & c after delivery..	10	\$439		
59200		Insert cervical dilator	0	\$103		
59300		Episiotomy or vaginal repair	0	\$248		
59320		Revision of cervix	0	\$331		
59325		Revision of cervix	0	\$514		
59350		Repair of uterus	0	\$659		
59400		Obstetrical care		\$2,793		
59409		Obstetrical care		\$1,767		
59410		Obstetrical care		\$1,921		
59412		Antepartum manipulation		\$228		
59414		Deliver placenta		\$215		
59425		Antepartum care only		\$537		
59426		Antepartum care only		\$920		



Title 40, Part I

CPT Code	Mod	Description	Global Days	Maximum Allowance	Non-Facility Maximum	Facility Maximum
59430		Care after delivery		\$174		
59510		Cesarean delivery		\$3,149		
59514		Cesarean delivery only		\$2,048		
59515		Cesarean delivery		\$2,201		
59525		Remove uterus after cesarean		\$923		
59610		Vbac delivery.....		\$2,930		
59612		Vbac delivery only....		\$1,816		
59614		Vbac care after delivery		\$1,972		
59618		Attempted vbc delivery		\$3,311		
59620		Attempted vbc delivery only		\$2,110		
59622		Attempted vbc after care		\$2,277		
59812		Treatment of miscarriage	90	\$530		
59820		Care of miscarriage	90	\$584		
59821		Treatment of miscarriage	90	\$539		
59830		Treat uterus infection	90	\$780		
59840		Abortion	10	\$483		
59841		Abortion	10	\$549		
59850		Abortion	90	\$730		
59851		Abortion	90	\$763		
59852		Abortion	90	\$1,025		
59855		Abortion	90	\$624		
59856		Abortion	90	\$942		
59857		Abortion	90	\$1,146		
59866		Abortion (mpr).....	0	\$512		
59870		Evacuate mole of uterus	90	\$543		
59871		Remove cerclage suture	0	\$302		
59898		Laparo proc, ob care/deliver		BR		
59899		Maternity care procedure		BR		
60000		Drain thyroid/tongue cyst	10	\$171		
60100		Biopsy of thyroid.....	0	\$173		
60200		Remove thyroid lesion	90	\$1,125		
60210		Partial excision thyroid	90	\$1,459		
60212		Partial thyroid excision	90	\$1,838		
60220		Partial removal of thyroid	90	\$1,427		
60225		Partial removal of thyroid	90	\$1,840		
60240		Removal of thyroid	90	\$1,996		
60252		Removal of thyroid	90	\$2,237		
60254		Extensive thyroid surgery	90	\$2,758		
60260		Repeat thyroid surgery	90	\$1,451		
60270		Removal of thyroid....	90	\$2,385		
60271		Removal of thyroid	90	\$1,999		
60280		Remove thyroid duct lesion	90	\$989		
60281		Remove thyroid duct lesion	90	\$991		
60300		Aspir/inj thyroid cyst			\$235	\$101
60500		Explore parathyroid glands	90	\$2,058		
60502		Re-explore parathyroids	90	\$2,334		
60505		Explore parathyroid glands	90	\$2,523		
60512		Autotransplant parathyroid		\$508		
60520		Removal of thymus gland	90	\$2,247		
60521		Removal thymus gland	90	\$2,366		
60522		Removal of thymus gland	90	\$2,643		
60540		Explore adrenal gland	90	\$2,112		
60545		Explore adrenal gland	90	\$2,487		
60600		Remove carotid body lesion	90	\$2,086		
60605		Remove carotid body lesion	90	\$2,203		
60650		Laparoscopy adrenalectomy		\$2,465		
60659		Laparo proc, endocrine		BR		
60699		Endocrine surgery procedure		BR		
61000		Remove cranial cavity fluid	0	\$200		
61001		Remove cranial cavity fluid	0	\$180		
61020		Remove brain cavity fluid	0	\$210		
61026		Injection into brain canal	0	\$279		
61050		Remove brain canal fluid	0	\$205		
61055		Injection into brain canal	0	\$295		
61070		Brain canal shunt procedure	0	\$101		
61105		Twist drill hole.....	90	\$813		

LABOR AND EMPLOYMENT

CPT Code	Mod	Description	Global Days	Maximum Allowance	Non-Facility Maximum	Facility Maximum
61107		Drill skull for implantation	0	\$847		
61108		Drill skull for drainage	90	\$1,774		
61120		Burr hole for puncture	90	\$1,112		
61140		Pierce skull for biopsy	90	\$2,232		
61150		Pierce skull for drainage	90	\$2,382		
61151		Pierce skull for drainage	90	\$984		
61154		Pierce skull, remove clot	90	\$2,438		
61156		Pierce skull for drainage	90	\$2,440		
61210		Pierce skull; implant device	0	\$971		
61215		Insert brain-fluid device	90	\$1,464		
61250		Pierce skull & explore	90	\$1,452		
61253		Pierce skull & explore	90	\$1,721		
61304		Open skull for exploration	90	\$3,641		
61305		Open skull for exploration	90	\$4,172		
61312		Open skull for drainage	90	\$3,478		
61313		Open skull for drainage	90	\$3,466		
61314		Open skull for drainage	90	\$3,757		
61315		Open skull for drainage	90	\$3,878		
61316		Implt cran bone flap to abdo		\$183		
61320		Open skull for drainage	90	\$3,258		
61321		Open skull for drainage	90	\$3,542		
61322		Decompressive craniotomy		\$4,954		
61323		Decompressive lobectomy		\$4,975		
61330		Decompress eye socket	90	\$2,112		
61332		Explore/biopsy eye socket	90	\$3,508		
61333		Explore orbit; remove lesion	90	\$3,573		
61334		Explore orbit; remove object	90	\$2,374		
61340		Relieve cranial pressure	90	\$2,046		
61343		Incise skull, pressure relief	90	\$4,473		
61345		Relieve cranial pressure	90	\$3,397		
61440		Incise skull for surgery	90	\$3,436		
61450		Incise skull for surgery	90	\$3,409		
61458		Incise skull for brain wound	90	\$4,114		
61460		Incise skull for surgery	90	\$3,948		
61470		Incise skull for surgery	90	\$2,632		
61480		Incise skull for surgery	90	\$2,380		
61490		Incise skull for surgery	90	\$2,089		
61500		Removal of skull lesion	90	\$2,873		
61501		Remove infected skull bone	90	\$2,448		
61510		Removal of brain lesion	90	\$3,916		
61512		Remove brain lining lesion	90	\$4,145		
61514		Removal of brain abscess	90	\$3,804		
61516		Removal of brain lesion	90	\$3,814		
61517		Implt brain chemotx add-on		\$181		
61518		Removal of brain lesion	90	\$4,795		
61519		Remove brain lining lesion	90	\$5,014		
61520		Removal of brain lesion	90	\$5,528		
61521		Removal of brain lesion	90	\$5,543		
61522		Removal of brain abscess	90	\$3,631		
61524		Removal of brain lesion	90	\$4,150		
61526		Removal of brain lesion	90	\$4,849		
61530		Removal of brain lesion	90	\$6,260		
61531		Implant brain electrodes	90	\$2,636		
61533		Implant brain electrodes	90	\$3,098		
61534		Removal of brain lesion	90	\$1,948		
61535		Remove brain electrodes	90	\$1,355		
61536		Removal of brain lesion	90	\$3,920		
61537		Removal of brain tissue		\$5,128		
61538		Removal of brain tissue	90	\$4,396		
61539		Removal of brain tissue	90	\$4,041		
61540		Removal of brain tissue		\$4,552		
61541		Incision of brain tissue	90	\$3,577		
61542		Removal of brain tissue	90	\$3,624		
61543		Removal of brain tissue	90	\$2,856		
61544		Remove & treat brain lesion	90	\$3,822		
61545		Excision of brain tumor	90	\$4,598		

Title 40, Part I

CPT Code	Mod	Description	Global Days	Maximum Allowance	Non-Facility Maximum	Facility Maximum
61546		Removal of pituitary gland	90	\$4,326		
61548		Removal of pituitary gland	90	\$3,465		
61550		Release of skull seams	90	\$1,923		
61552		Release of skull seams	90	\$2,516		
61556		Incise skull/sutures	90	\$3,555		
61557		Incise skull/sutures	90	\$3,509		
61558		Excision of skull/sutures	90	\$3,917		
61559		Excision of skull/sutures	90	\$3,786		
61563		Excision of skull tumor	90	\$4,128		
61564		Excision of skull tumor	90	\$5,016		
61567		Incision of brain tissue		\$5,345		
61570		Remove brain foreign body	90	\$3,003		
61571		Incise skull for brain wound	90	\$3,262		
61575		Skull base/brainstem surgery	90	\$4,982		
61576		Skull base/brainstem surgery	90	\$4,669		
61580		Craniofacial approach, skull	90	\$3,823		
61581		Craniofacial approach, skull	90	\$4,339		
61582		Craniofacial approach, skull	90	\$3,939		
61583		Craniofacial approach, skull	90	\$4,494		
61584		Orbitocranial approach/skull	90	\$4,352		
61585		Orbitocranial approach/skull	90	\$4,869		
61586		Resect nasopharynx, skull.	90	\$3,400		
61590		Infratemporal approach/skull	90	\$5,295		
61591		Infratemporal approach/skull	90	\$5,554		
61592		Orbitocranial approach/skull	90	\$5,037		
61595		Transmastoid approach/skull	90	\$3,720		
61596		Transcochlear approach/skull	90	\$4,521		
61597		Transcondylar approach/skull	90	\$4,779		
61598		Transpetrosal approach/skull	90	\$4,210		
61600		Resect/excise cranial lesion	90	\$3,229		
61601		Resect/excise cranial lesion	90	\$3,462		
61605		Resect/excise cranial lesion	90	\$3,655		
61606		Resect/excise cranial lesion	90	\$4,895		
61607		Resect/excise cranial lesion	90	\$4,572		
61608		Resect/excise cranial lesion	90	\$5,320		
61609		Transect artery, sinus		\$1,275		
61610		Transect artery, sinus		\$3,762		
61611		Transect artery, sinus		\$945		
61612		Transect artery, sinus		\$3,551		
61613		Remove aneurysm, sinus	90	\$5,218		
61615		Resect/excise lesion, skull	90	\$4,017		
61616		Resect/excise lesion, skull	90	\$5,463		
61618		Repair dura	90	\$2,066		
61619		Repair dura	90	\$2,583		
61623		Endovasc tempory vessel occl		\$1,147		
61624		Occlusion/embolization cath	0	\$2,635		
61626		Occlusion/embolization cath	0	\$2,173		
61630		Intracranial angioplasty		\$2,577		
61635		Intracran angioplasty w/stent		\$2,837		
61640		Dilate ic vasospasm init		\$1,288		
61641		Dilate ic vasospasm add-on		\$453		
61642		Dilate ic vasospasm add-on		\$905		
61680		Intracranial vessel surgery	90	\$5,189		
61682		Intracranial vessel surgery	90	\$5,937		
61684		Intracranial vessel surgery	90	\$5,131		
61686		Intracranial vessel surgery	90	\$6,203		
61690		Intracranial vessel surgery	90	\$4,628		
61692		Intracranial vessel surgery	90	\$4,963		
61697		Brain aneurysm repr complx		\$8,800		
61698		Brain aneurysm repr complx		\$9,656		
61700		Inner skull vessel surgery	90	\$5,110		
61702		Inner skull vessel surgery	90	\$5,813		
61703		Clamp neck artery	90	\$2,175		
61705		Revise circulation to head	90	\$4,966		
61708		Revise circulation to head	90	\$4,326		
61710		Revise circulation to head	90	\$3,293		

LABOR AND EMPLOYMENT

CPT Code	Mod	Description	Global Days	Maximum Allowance	Non-Facility Maximum	Facility Maximum
61711		Fusion of skull arteries	90	\$5,229		
61720		Incise skull/brain surgery	90	\$3,010		
61735		Incise skull/brain surgery	90	\$2,233		
61750		Incise skull; brain biopsy	90	\$2,469		
61751		Brain biopsy w/ ct/mr guide	90	\$2,774		
61760		Implant brain electrodes	90	\$2,943		
61770		Incise skull for treatment	90	\$2,687		
61781		Scan proc cranial intra		\$489		
61782		Scan proc cranial extra		\$402		
61783		Scan proc spinal		\$489		
61790		Treat trigeminal nerve	90	\$2,040		
61791		Treat trigeminal tract	90	\$1,785		
61796		Srs cranial lesion simple		\$2,096		
61797		Srs cran les simple addl		\$453		
61798		Srs cranial lesion complex		\$2,860		
61799		Srs cran les complex addl		\$626		
61800		Apply srs headframe add-on		\$317		
61850		Implant neuroelectrodes	90	\$1,797		
61860		Implant neuroelectrodes	90	\$2,236		
61863		Implant neuroelectrode		\$3,137		
61864		Implant neuroelectrde addl		\$592		
61867		Implant neuroelectrode		\$4,760		
61868		Implant neuroelectrde addl		\$1,042		
61870		Implant neuroelectrodes	90	\$763		
61875		Implant neuroelectrodes	90	\$1,217		
61880		Revise/remove neuroelectrode	90	\$791		
61885		Implant neurostim one array	90	\$619		
61886		Implant neurostim arrays	90	\$1,778		
61888		Revise/remove neuroreceiver	10	\$409		
62000		Repair of skull fracture	90	\$1,270		
62005		Repair of skull fracture	90	\$1,974		
62010		Treatment of head injury	90	\$2,903		
62100		Repair brain fluid leakage	90	\$3,265		
62115		Reduction of skull defect	90	\$2,611		
62116		Reduction of skull defect	90	\$3,699		
62117		Reduction of skull defect	90	\$3,234		
62120		Repair skull cavity lesion	90	\$3,564		
62121		Incise skull repair	90	\$2,915		
62140		Repair of skull defect	90	\$2,014		
62141		Repair of skull defect	90	\$2,471		
62142		Remove skull plate/flap	90	\$1,810		
62143		Replace skull plate/flap	90	\$1,623		
62145		Repair of skull & brain	90	\$2,346		
62146		Repair of skull with graft	90	\$2,000		
62147		Repair of skull with graft	90	\$2,399		
62148		Retr bone flap to fix skull		\$264		
62160		Neuroendoscopy add-on		\$394		
62161		Dissect brain w/scope		\$3,159		
62162		Remove colloid cyst w/scope		\$3,942		
62163		Zneuroendoscopy w/fb removal		\$2,557		
62164		Remove brain tumor w/scope		\$4,359		
62165		Remove pituit tumor w/scope		\$3,244		
62180		Establish brain cavity shunt	90	\$2,098		
62190		Establish brain cavity shunt	90	\$1,994		
62192		Establish brain cavity shunt	90	\$2,020		
62194		Replace/irrigate catheter	10	\$353		
62200		Establish brain cavity shunt	90	\$2,356		
62201		Establish brain cavity shunt	90	\$1,600		
62220		Establish brain cavity shunt	90	\$2,197		
62223		Establish brain cavity shunt	90	\$2,281		
62225		Replace/irrigate catheter	90	\$714		
62230		Replace/revise brain shunt	90	\$1,512		
62252	TC	Csf shunt reprogram		\$96		
62252	26	Csf shunt reprogram		\$82		
62252		Csf shunt reprogram		\$178		
62256		Remove brain cavity shunt	90	\$952		

Title 40, Part I

CPT Code	Mod	Description	Global Days	Maximum Allowance	Non-Facility Maximum	Facility Maximum
62258		Replace brain cavity shunt	90	\$2,189		
62263		Lysis epidural adhesions	0			
62263		Lysis epidural adhesions	0		\$1,462	\$721
62264		Epidural lysis on single day			\$918	\$505
62267		Interdiscal perq aspir dx			\$504	\$322
62268		Drain spinal cord cyst	0	\$510		
62269		Needle biopsy spinal cord	0	\$432		
62270		Spinal fluid tap, diagnostic	0	\$135		
62272		Drain spinal fluid	0	\$176		
62273		Treat epidural spine lesion	0	\$251		
62280		Treat spinal cord lesion	10	\$295		
62281		Treat spinal cord lesion	10	\$266		
62282		Treat spinal canal lesion	10	\$352		
62284		Injection for myelogram	0	\$279		
62287		Percutaneous discectomy	90	\$1,197		
62290		Inject for spine disk X-ray	0	\$402		
62291		Inject for spine disk X-ray	0	\$393		
62292		Injection into disk lesion	90	\$1,450		
62294		Injection into spinal artery	90	\$1,032		
62310		Inject spine c/t.....	0	BR		
62311		Inject spine l/s (cd)	0	BR		
62318		Inject spine w/cath, c t	0	\$530		
62319		Inject spine w/cath l/ s (cd)	0		\$364	\$203
62350		Implant spinal canal cath	90	\$800		
62351		Implant spinal canal cath	90	\$1,199		
62355		Remove spinal canal catheter	90	\$659		
62360		Insert spine infusion device	90	\$305		
62361		Implant spine infusion pump	90	\$630		
62362		Implant spine infusion pump	90	\$823		
62365		Remove spine infusion device	90	\$667		
62367		Analyze spine infusion pump		BR		
62367	26	Analyze spine infusion pump		\$59		
62367	TC	Analyze spine infusion pump		BR		
62368		Analyze spine infusion pump		BR		
62368	26	Analyze spine infusion pump		\$93		
62368	TC	Analyze spine infusion pump		BR		
62369		Anal sp inf pmp w/reprg&fill			\$256	\$72
62370		Anl sp inf pmp w/mdreprg&fil			\$268	\$97
63001		Removal of spinal lamina	90	\$2,582		
63003		Removal of spinal lamina	90	\$2,534		
63005		Removal of spinal lamina	90	\$2,403		
63011		Removal of spinal lamina	90	\$1,626		
63012		Removal of spinal lamina	90	\$2,508		
63015		Removal of spinal lamina	90	\$2,994		
63016		Removal of spinal lamina	90	\$3,104		
63017		Removal of spinal lamina	90	\$2,900		
63020		Neck spine disk surgery	90	\$2,331		
63030		Low back disk surgery	90	\$1,906		
63035		Spinal disk surgery add-on		\$498		
63040		Neck spine disk surgery	90	\$3,139		
63042		Low back disk surgery	90	\$3,140		
63045		Removal of spinal lamina	90	\$2,949		
63046		Removal of spinal lamina	90	\$2,939		
63047		Removal of spinal lamina	90	\$2,819		
63048		Remove spinal lamina add-on		\$530		
63050		Cervical laminoplasty		\$3,231		
63051		C-laminoplasty w/graft/plate		\$3,577		
63055		Decompress spinal cord	90	\$3,439		
63056		Decompress spinal cord	90	\$3,114		
63057		Decompress spine cord add-on		\$691		
63064		Decompress spinal cord	90	\$3,622		
63066		Decompress spine cord add-on		\$433		
63075		Neck spine disk surgery	90	\$2,871		
63076		Neck spine disk surgery		\$640		
63077		Spine disk surgery, thorax	90	\$2,962		
63078		Spine disk surgery, thorax		\$442		

LABOR AND EMPLOYMENT

CPT Code	Mod	Description	Global Days	Maximum Allowance	Non-Facility Maximum	Facility Maximum
63081		Removal of vertebral body	90	\$3,741		
63082		Remove vertebral body add-on		\$699		
63085		Removal of vertebral body	90	\$4,045		
63086		Remove vertebral body add-on		\$522		
63087		Removal of vertebral body	90	\$4,294		
63088		Remove vertebral body add-on		\$691		
63090		Removal of vertebral body	90	\$4,270		
63091		Remove vertebral body add-on		\$428		
63101		Removal of vertebral body		\$4,842		
63102		Removal of vertebral body		\$4,673		
63103		Remove vertebral body add-on		\$607		
63170		Incise spinal cord tract(s)	90	\$2,856		
63172		Drainage of spinal cyst	90	\$3,047		
63173		Drainage of spinal cyst	90	\$2,667		
63180		Revise spinal cord ligaments	90	\$2,153		
63182		Revise spinal cord ligaments	90	\$2,658		
63185		Incise spinal column/nerves	90	\$2,288		
63190		Incise spinal column/nerves	90	\$2,901		
63191		Incise spinal column/nerves	90	\$2,242		
63194		Incise spinal column & cord	90	\$2,327		
63195		Incise spinal column & cord	90	\$2,345		
63196		Incise spinal column & cord	90	\$2,689		
63197		Incise spinal column & cord	90	\$2,574		
63198		Incise spinal column & cord	90	\$2,971		
63199		Incise spinal column & cord	90	\$3,391		
63200		Release of spinal cord	90	\$2,264		
63250		Revise spinal cord vessels	90	\$5,088		
63251		Revise spinal cord vessels	90	\$4,666		
63252		Revise spinal cord vessels	90	\$5,140		
63265		Excise intraspinal lesion	90	\$3,252		
63266		Excise intraspinal lesion	90	\$3,528		
63267		Excise intraspinal lesion	90	\$3,020		
63268		Excise intraspinal lesion	90	\$2,286		
63270		Excise intraspinal lesion	90	\$3,285		
63271		Excise intraspinal lesion	90	\$3,989		
63272		Excise intraspinal lesion	90	\$3,617		
63273		Excise intraspinal lesion	90	\$3,068		
63275		Biopsy/excise spinal tumor	90	\$3,891		
63276		Biopsy/excise spinal tumor	90	\$3,659		
63277		Biopsy/excise spinal tumor	90	\$3,363		
63278		Biopsy/excise spinal tumor	90	\$3,320		
63280		Biopsy/excise spinal tumor	90	\$4,233		
63281		Biopsy/excise spinal tumor	90	\$4,180		
63282		Biopsy/excise spinal tumor	90	\$3,788		
63283		Biopsy/excise spinal tumor	90	\$3,241		
63285		Biopsy/excise spinal tumor	90	\$4,475		
63286		Biopsy/excise spinal tumor	90	\$4,786		
63287		Biopsy/excise spinal tumor	90	\$4,578		
63290		Biopsy/excise spinal tumor	90	\$4,732		
63295		Repair of laminectomy defect		\$692		
63300		Removal of vertebral body	90	\$2,978		
63301		Removal of vertebral body	90	\$3,335		
63302		Removal of vertebral body	90	\$3,538		
63303		Removal of vertebral body	90	\$3,566		
63304		Removal of vertebral body	90	\$3,674		
63305		Removal of vertebral body	90	\$3,940		
63306		Removal of vertebral body	90	\$3,923		
63307		Removal of vertebral body	90	\$4,022		
63308		Remove vertebral body add-on		\$691		
63600		Remove spinal cord lesion	90	\$1,870		
63610		Stimulation of spinal cord	0	\$1,240		
63615		Remove lesion of spinal cord	90	\$2,051		
63620		Srs spinal lesion		\$2,311		
63621		Srs spinal lesion addl		\$520		
63650		Implant neuroelectrodes	90	\$1,059		
63655		Implant neuroelectrodes	90	\$1,704		

Title 40, Part I

CPT Code	Mod	Description	Global Days	Maximum Allowance	Non-Facility Maximum	Facility Maximum
63660		Revise/remove neuroelectrode	90	\$962		
63661		Remove spine eltrd perq aray			\$1,234	\$667
63662		Remove spine eltrd plate		\$1,626		
63663		Revise spine eltrd perq aray			\$1,754	\$973
63664		Revise spine eltrd plate		\$1,665		
63685		Implant neuroreceiver	90	\$1,073		
63688		Revise/remove neuroreceiver	90	\$871		
63700		Repair of spinal herniation	90	\$2,712		
63702		Repair of spinal herniation	90	\$2,968		
63704		Repair of spinal herniation	90	\$3,443		
63706		Repair of spinal herniation	90	\$3,830		
63707		Repair spinal fluid leakage	90	\$1,867		
63709		Repair spinal fluid leakage	90	\$2,375		
63710		Graft repair of spine defect	90	\$1,723		
63740		Install spinal shunt	90	\$1,994		
63741		Install spinal shunt	90	\$1,475		
63744		Revision of spinal shunt	90	\$1,180		
63746		Removal of spinal shunt	90	\$864		
64400		Injection for nerve block	0	\$117		
64402		Injection for nerve block	0	\$139		
64405		Injection for nerve block	0	\$144		
64408		Injection for nerve block	0	\$182		
64410		Injection for nerve block	0	\$163		
64412		Injection for nerve block	0	\$133		
64413		Injection for nerve block	0	\$158		
64415		Injection for nerve block	0	\$129		
64417		Injection for nerve block	0	\$158		
64418		Injection for nerve block	0	\$161		
64420		Injection for nerve block	0	\$134		
64421		Injection for nerve block	0	\$190		
64425		Injection for nerve block	0	\$172		
64430		Injection for nerve block	0	\$162		
64435		Injection for nerve block	0	\$143		
64445		Injection for nerve block	0	\$145		
64446		N blk inj sciatic cont inf		\$169		
64447		N block inj fem single			\$255	\$138
64448		N block inj fem cont inf		\$151		
64449		N block inj lumbar plexus		\$176		
64450		Injection for nerve block	0	\$131		
64455		N block inj plantar digit			\$98	\$73
64479		Inj foramen epidural c t	0	BR		
64480		Inj foramen epidural add-on	0	BR		
64483		Inj foramen epidural l s	0	BR		
64484		Inj foramen epidural add-on		BR		
64490		Inj paravert f jnt c/t 1 lev		BR		
64491		Inj paravert f jnt c/t 2 lev		BR		
64492		Inj paravert f jnt c/t 3 lev		BR		
64493		Inj paravert f jnt l/s 1 lev		BR		
64494		Inj paravert f jnt l/s 2 lev		BR		
64495		Inj paravert f jnt l/s 3 lev		BR		
64505		Injection for nerve block	0	\$145		
64508		Injection for nerve block	0	\$159		
64510		Injection for nerve block	0	\$150		
64517		N block inj hypogas plxs			\$391	\$266
64520		Injection for nerve block	0	\$159		
64530		Injection for nerve block	0	\$215		
64550		Apply neurostimulator	0	\$47		
64553		Implant neuroelectrodes	10	\$240		
64555		Implant neuroelectrodes	10	\$194		
64561		Implant neuroelectrodes			\$1,629	\$813
64565		Implant neuroelectrodes	10	\$181		
64566		Neuroeltrd stim post tibial		\$275		
64568		Inc for vagus n elect impl		\$1,319		
64569		Revise/repl vagus n eltrd		\$1,441		
64570		Remove vagus n eltrd		\$1,160		
64575		Implant neuroelectrodes	90	\$548		

LABOR AND EMPLOYMENT

CPT Code	Mod	Description	Global Days	Maximum Allowance	Non-Facility Maximum	Facility Maximum
64580		Implant neuroelectrodes	90	\$506		
64581		Implant neuroelectrodes		\$1,376		
64585		Revise/remove neuroelectrode	10	\$217		
64590		Implant neuroreceiver	10	\$322		
64595		Revise/remove neuroreceiver	10	\$213		
64600		Injection treatment of nerve	10	\$373		
64605		Injection treatment of nerve	10	\$528		
64610		Injection treatment of nerve	10	\$1,113		
64611		Chemodenerv saliv glands			\$208	\$186
64612		Destroy nerve, face muscle	10	\$272		
64613		Destroy nerve, spine muscle	10	\$250		
64614		Destroy nerve extrem musc		BR		
64620		Injection treatment of nerve	10	\$301		
64630		Injection treatment of nerve	10	\$359		
64632		N block inj common digit		BR		
64633		Destroy cerv/thor facet jnt		BR		
64634		Destroy c/th facet jnt addl		BR		
64635		Destroy lumb/sac facet jnt		BR		
64636		Destroy l/s facet jnt addl		BR		
64640		Injection treatment of nerve	10	\$248		
64650		Chemodenerv eccrine glands			\$251	\$83
64653		Chemodenerv eccrine glands			\$294	\$108
64680		Injection treatment of nerve	10	\$321		
64681		Injection treatment of nerve			\$774	\$408
64702		Revise finger/toe nerve	90	\$633		
64704		Revise hand/foot nerve	90	\$748		
64708		Revise arm/leg nerve	90	\$1,011		
64712		Revision of sciatic nerve	90	\$1,278		
64713		Revision of arm nerve(s)	90	\$1,519		
64714		Revise low back nerve(s)	90	\$1,233		
64716		Revision of cranial nerve	90	\$800		
64718		Revise ulnar nerve at elbow	90	\$943		
64719		Revise ulnar nerve at wrist	90	\$745		
64721		Carpal tunnel surgery	90	\$688		
64722		Relieve pressure on nerve(s)	90	\$829		
64726		Release foot/toe nerve	90	\$337		
64727		Internal nerve revision		\$488		
64732		Incision of brow nerve	90	\$651		
64734		Incision of cheek nerve	90	\$701		
64736		Incision of chin nerve	90	\$657		
64738		Incision of jaw nerve	90	\$787		
64740		Incision of tongue nerve	90	\$785		
64742		Incision of facial nerve	90	\$804		
64744		Incise nerve, back of head	90	\$854		
64746		Incise diaphragm nerve	90	\$719		
64752		Incision of vagus nerve	90	\$808		
64755		Incision of stomach nerves	90	\$1,830		
64760		Incision of vagus nerve	90	\$1,040		
64761		Incision of pelvis nerve	90	\$798		
64763		Incise hip/thigh nerve	90	\$880		
64766		Incise hip/thigh nerve	90	\$1,145		
64771		Sever cranial nerve	90	\$1,001		
64772		Incision of spinal nerve	90	\$1,053		
64774		Remove skin nerve lesion	90	\$570		
64776		Remove digit nerve lesion	90	\$570		
64778		Digit nerve surgery add-on		\$427		
64782		Remove limb nerve lesion	90	\$777		
64783		Limb nerve surgery add on		\$510		
64784		Remove nerve lesion	90	\$1,137		
64786		Remove sciatic nerve lesion	90	\$2,117		
64787		Implant nerve end		\$593		
64788		Remove skin nerve lesion	90	\$598		
64790		Removal of nerve lesion	90	\$1,365		
64792		Removal of nerve lesion	90	\$1,774		
64795		Biopsy of nerve	0	\$409		
64802		Remove sympathetic nerves	90	\$1,042		



Title 40, Part I

CPT Code	Mod	Description	Global Days	Maximum Allowance	Non-Facility Maximum	Facility Maximum
64804		Remove sympathetic nerves	90	\$2,043		
64809		Remove sympathetic nerves	90	\$1,797		
64818		Remove sympathetic nerves	90	\$1,396		
64820		Remove sympathetic nerves	90	\$1,191		
64821		Remove sympathetic nerves		\$1,481		
64822		Remove sympathetic nerves		\$1,436		
64823		Remove sympathetic nerves		\$1,633		
64831		Repair of digit nerve	90	\$906		
64832		Repair nerve add-on...		\$548		
64834		Repair of hand or foot nerve	90	\$980		
64835		Repair of hand or foot nerve	90	\$1,237		
64836		Repair of hand or foot nerve	90	\$1,302		
64837		Repair nerve add-on...		\$802		
64840		Repair of leg nerve	90	\$1,651		
64856		Repair/transpose nerve	90	\$1,592		
64857		Repair arm/leg nerve	90	\$1,735		
64858		Repair sciatic nerve	90	\$2,019		
64859		Nerve surgery.....		\$574		
64861		Repair of arm nerves	90	\$2,318		
64862		Repair of low back nerves	90	\$2,924		
64864		Repair of facial nerve	90	\$1,479		
64865		Repair of facial nerve	90	\$2,021		
64866		Fusion of facial/other nerve	90	\$1,980		
64868		Fusion of facial/other nerve	90	\$1,842		
64870		Fusion of facial/other nerve	90	\$2,180		
64872		Subsequent repair of nerve		\$248		
64874		Repair and revise nerve		\$351		
64876		Repair nerve; shorten bone		\$379		
64885		Nerve graft, head or neck	90	\$2,188		
64886		Nerve graft, head or neck	90	\$2,609		
64890		Nerve graft, hand or foot	90	\$2,034		
64891		Nerve graft, hand or foot	90	\$1,937		
64892		Nerve graft, arm or leg	90	\$1,881		
64893		Nerve graft, arm or leg	90	\$2,181		
64895		Nerve graft, hand or foot	90	\$2,414		
64896		Nerve graft, hand or foot	90	\$2,748		
64897		Nerve graft, arm or leg	90	\$2,299		
64898		Nerve graft, arm or leg	90	\$2,488		
64901		Nerve graft add-on....		\$1,442		
64902		Nerve graft add-on....		\$1,685		
64905		Nerve pedicle transfer	90	\$1,651		
64907		Nerve pedicle transfer	90	\$2,369		
64910		Nerve repair w/allograft		\$1,740		
64911		Neurorrhaphy w/vein autograft		\$2,185		
64999		Nervous system surgery		BR		
65091		Revise eye	90	\$1,031		
65093		Revise eye with implant	90	\$1,141		
65101		Removal of eye	90	\$1,086		
65103		Remove eye/insert implant	90	\$1,176		
65105		Remove eye/attach implant	90	\$1,302		
65110		Removal of eye	90	\$2,146		
65112		Remove eye, revise socket	90	\$2,031		
65114		Remove eye, revise socket	90	\$2,217		
65125		Revise ocular implant	90	\$435		
65130		Insert ocular implant	90	\$1,126		
65135		Insert ocular implant	90	\$899		
65140		Attach ocular implant	90	\$992		
65150		Revise ocular implant	90	\$1,147		
65155		Reinsert ocular implant	90	\$1,534		
65175		Removal of ocular implant	90	\$978		
65205		Remove foreign body from eye	0	\$83		
65210		Remove foreign body from eye	0	\$95		
65220		Remove foreign body from eye	0	\$91		
65222		Remove foreign body from eye	0	\$109		
65235		Remove foreign body from eye	90	\$922		
65260		Remove foreign body from eye	90	\$1,376		

LABOR AND EMPLOYMENT

CPT Code	Mod	Description	Global Days	Maximum Allowance	Non-Facility Maximum	Facility Maximum
65265		Remove foreign body from eye	90	\$1,599		
65270		Repair of eye wound	10	\$219		
65272		Repair of eye wound	90	\$376		
65273		Repair of eye wound	90	\$518		
65275		Repair of eye wound	90	\$407		
65280		Repair of eye wound	90	\$1,181		
65285		Repair of eye wound	90	\$1,767		
65286		Repair of eye wound	90	\$722		
65290		Repair of eye socket wound	90	\$824		
65400		Removal of eye lesion	90	\$879		
65410		Biopsy of cornea	0	\$225		
65420		Removal of eye lesion	90	\$600		
65426		Removal of eye lesion	90	\$854		
65430		Corneal smear	0	\$103		
65435		Curette/treat cornea	0	\$123		
65436		Curette/treat cornea	90	\$397		
65450		Treatment of corneal lesion	90	\$462		
65600		Revision of cornea	90	\$418		
65710		Corneal transplant	90	\$2,051		
65730		Corneal transplant	90	\$2,450		
65750		Corneal transplant	90	\$2,557		
65755		Corneal transplant	90	\$2,618		
65756		Corneal trnspl endothelial		\$2,411		
65760		Revision of cornea		BR		
65765		Revision of cornea		BR		
65767		Corneal tissue transplant		BR		
65770		Revise cornea with implant	90	\$2,200		
65771		Radial keratotomy		BR		
65772		Correction of astigmatism	90	\$691		
65775		Correction of astigmatism	90	\$1,037		
65778		Cover eye w/membrane			\$2,775	\$150
65779		Cover eye w/membrane suture			\$2,471	\$592
65780		Ocular reconst transplant		\$1,849		
65781		Ocular reconst transplant		\$2,713		
65782		Ocular reconst transplant		\$2,470		
65800		Drainage of eye	0	\$264		
65805		Drainage of eye	0	\$271		
65810		Drainage of eye	90	\$731		
65815		Drainage of eye	90	\$671		
65820		Relieve inner eye pressure	90	\$1,250		
65850		Incision of eye	90	\$1,692		
65855		Laser surgery of eye	90	\$985		
65860		Incise inner eye adhesions	90	\$689		
65865		Incise inner eye adhesions	90	\$907		
65870		Incise inner eye adhesions	90	\$857		
65875		Incise inner eye adhesions	90	\$903		
65880		Incise inner eye adhesions	90	\$985		
65900		Remove eye lesion	90	\$1,364		
65920		Remove implant from eye	90	\$1,182		
65930		Remove blood clot from eye	90	\$1,071		
66020		Injection treatment of eye	10	\$280		
66030		Injection treatment of eye	10	\$126		
66130		Remove eye lesion	90	\$927		
66150		Glaucoma surgery	90	\$1,301		
66155		Glaucoma surgery	90	\$1,243		
66160		Glaucoma surgery	90	\$1,473		
66165		Glaucoma surgery	90	\$1,267		
66170		Glaucoma surgery	90	\$1,706		
66172		Incision of eye	90	\$1,873		
66174		Trnslum dil eye canal		\$2,017		
66175		Trnslum dil eye canal w/stnt		\$2,276		
66180		Implant eye shunt	90	\$2,166		
66185		Revise eye shunt	90	\$1,290		
66220		Repair eye lesion	90	\$964		
66225		Repair/graft eye lesion	90	\$1,883		
66250		Follow-up surgery of eye	90	\$935		

Title 40, Part I

CPT Code	Mod	Description	Global Days	Maximum Allowance	Non-Facility Maximum	Facility Maximum
66500		Incision of iris	90	\$600		
66505		Incision of iris	90	\$522		
66600		Remove iris and lesion	90	\$1,281		
66605		Removal of iris	90	\$1,762		
66625		Removal of iris	90	\$964		
66630		Removal of iris	90	\$1,006		
66635		Removal of iris	90	\$1,064		
66680		Repair iris & ciliary body	90	\$843		
66682		Repair iris and ciliary body	90	\$961		
66700		Destruction, ciliary body	90	\$771		
66710		Destruction, ciliary body	90	\$836		
66711		Ciliary endoscopic ablation		\$1,295		
66720		Destruction, ciliary body	90	\$806		
66740		Destruction, ciliary body	90	\$828		
66761		Revision of iris	90	\$854		
66762		Revision of iris	90	\$992		
66770		Removal of inner eye lesion	90	\$927		
66820		Incision, secondary cataract	90	\$642		
66821		After cataract laser surgery	90	\$637		
66825		Reposition intraocular lens	90	\$1,093		
66830		Removal of lens lesion	90	\$1,124		
66840		Removal of lens material	90	\$1,251		
66850		Removal of lens material	90	\$1,501		
66852		Removal of lens material	90	\$1,806		
66920		Extraction of lens	90	\$1,407		
66930		Extraction of lens	90	\$1,473		
66940		Extraction of lens	90	\$1,421		
66982		Cataract surgery complex		\$2,227		
66983		Remove cataract, insert lens	90	\$1,771		
66984		Remove cataract, insert lens	90	\$1,895		
66985		Insert lens prosthesis	90	\$1,391		
66986		Exchange lens prosthesis	90	\$1,743		
66990		Ophthalmic endoscope add-on		\$184		
66999		Eye surgery procedure		BR		
67005		Partial removal of eye fluid	90	\$1,793		
67010		Partial removal of eye fluid	90	\$1,720		
67015		Release of eye fluid	90	\$955		
67025		Replace eye fluid	90	\$959		
67027		Implant eye drug system.	90	\$1,517		
67028		Injection eye drug	0	\$420		
67030		Incise inner eye strands	90	\$943		
67031		Laser surgery, eye strands	90	\$1,118		
67036		Removal of inner eye fluid	90	\$2,629		
67039		Laser treatment of retina	90	\$3,025		
67040		Laser treatment of retina	90	\$3,339		
67041		Vit for macular pucker		\$2,778		
67042		Vit for macular hole		\$3,176		
67043		Vit for membrane dissect		\$3,396		
67101		Repair, detached retina	90	\$1,340		
67105		Repair detached retina	90	\$1,201		
67107		Repair detached retina	90	\$2,249		
67108		Repair detached retina	90	\$3,158		
67110		Repair detached retina	90	\$1,744		
67112		Rerepair detached retina.	90	\$2,424		
67113		Repair retinal detach cplx		\$3,660		
67115		Release, encircling material	90	\$871		
67120		Remove eye implant material	90	\$931		
67121		Remove eye implant material	90	\$1,421		
67141		Treatment of retina	90	\$961		
67145		Treatment of retina	90	\$983		
67208		Treatment of retinal lesion	90	\$1,036		
67210		Treatment of retinal lesion	90	\$1,272		
67218		Treatment of retinal lesion	90	\$1,893		
67220		Treatment of choroid lesion	90	\$1,403		
67221		Ocular photodynamic ther			\$595	\$447
67225		Eye photodynamic ther add-on			\$60	\$57

LABOR AND EMPLOYMENT

CPT Code	Mod	Description	Global Days	Maximum Allowance	Non-Facility Maximum	Facility Maximum
67227		Treatment of retinal lesion	90	\$1,120		
67228		Treatment of retinal lesion	90	\$1,576		
67229		Tr retinal les preterm inf		\$2,262		
67250		Reinforce eye wall	90	\$1,115		
67255		Reinforce/graft eye wall	90	\$1,697		
67299		Eye surgery procedure		BR		
67311		Revise eye muscle.....	90	\$1,025		
67312		Revise two eye muscles	90	\$1,256		
67314		Revise eye muscle	90	\$1,268		
67316		Revise two eye muscles	90	\$1,430		
67318		Revise eye muscle(s)..	90	\$1,055		
67320		Revise eye muscle(s) add-on		\$986		
67331		Eye surgery follow-up add-on		\$902		
67332		Rerevise eye muscles add-on		\$1,005		
67334		Revise eye muscle w/suture		\$746		
67335		Eye suture during surgery		\$412		
67340		Revise eye muscle add- on		\$929		
67343		Release eye tissue	90	\$930		
67345		Destroy nerve of eye muscle	10	\$381		
67346		Biopsy eye muscle		\$434		
67399		Eye muscle surgery procedure		BR		
67400		Explore/biopsy eye socket	90	\$1,514		
67405		Explore/drain eye socket	90	\$1,245		
67412		Explore/treat eye socket	90	\$1,523		
67413		Explore/treat eye socket	90	\$1,304		
67414		Explore/decompress eye socket	90	\$1,337		
67415		Aspiration orbital contents	0	\$276		
67420		Explore/treat eye socket	90	\$2,212		
67430		Explore/treat eye socket	90	\$1,698		
67440		Explore/drain eye socket	90	\$2,075		
67445		Explore/decompress eye socket	90	\$1,774		
67450		Explore/biopsy eye socket	90	\$2,050		
67500		Inject/treat eye socket	0	\$112		
67505		Inject/treat eye socket	0	\$136		
67515		Inject/treat eye socket	0	\$86		
67550		Insert eye socket implant	90	\$1,417		
67560		Revise eye socket implant	90	\$1,337		
67570		Decompress optic nerve	90	\$1,449		
67599		Orbit surgery procedure		BR		
67700		Drainage of eyelid abscess	10	\$129		
67710		Incision of eyelid	10	\$145		
67715		Incision of eyelid fold	10	\$195		
67800		Remove eyelid lesion	10	\$166		
67801		Remove eyelid lesions	10	\$236		
67805		Remove eyelid lesions	10	\$257		
67808		Remove eyelid lesion(s)	90	\$411		
67810		Biopsy of eyelid	0	\$166		
67820		Revise eyelashes	0	\$91		
67825		Revise eyelashes.....	10	\$236		
67830		Revise eyelashes	10	\$322		
67835		Revise eyelashes	90	\$962		
67840		Remove eyelid lesion	10	\$232		
67850		Treat eyelid lesion	10	\$178		
67875		Closure of eyelid by suture	0	\$235		
67880		Revision of eyelid	90	\$546		
67882		Revision of eyelid	90	\$796		
67900		Repair brow defect	90	\$603		
67901		Repair eyelid defect	90	\$1,178		
67902		Repair eyelid defect	90	\$1,228		
67903		Repair eyelid defect	90	\$1,254		
67904		Repair eyelid defect	90	\$1,215		
67906		Repair eyelid defect	90	\$882		
67908		Repair eyelid defect	90	\$1,013		
67909		Revise eyelid defect	90	\$903		
67911		Revise eyelid defect	90	\$1,092		
67912		Correction eyelid w/implant			\$1,817	\$1,024

Title 40, Part I

CPT Code	Mod	Description	Global Days	Maximum Allowance	Non-Facility Maximum	Facility Maximum
67914		Repair eyelid defect	90	\$704		
67915		Repair eyelid defect	90	\$313		
67916		Repair eyelid defect	90	\$850		
67917		Repair eyelid defect	90	\$977		
67921		Repair eyelid defect	90	\$520		
67922		Repair eyelid defect	90	\$300		
67923		Repair eyelid defect	90	\$917		
67924		Repair eyelid defect	90	\$951		
67930		Repair eyelid wound	10	\$348		
67935		Repair eyelid wound	90	\$715		
67938		Remove eyelid foreign body	10	\$130		
67950		Revision of eyelid	90	\$943		
67961		Revision of eyelid	90	\$938		
67966		Revision of eyelid	90	\$1,162		
67971		Reconstruction of eyelid	90	\$1,479		
67973		Reconstruction of eyelid	90	\$1,914		
67974		Reconstruction of eyelid	90	\$1,947		
67975		Reconstruction of eyelid	90	\$941		
67999		Eyelid surgery procedure		BR		
68020		Incise/drain eyelid lining	10	\$132		
68040		Treatment of eyelid lesions	0	\$94		
68100		Biopsy of eyelid lining	0	\$171		
68110		Remove eyelid lining lesion	10	\$215		
68115		Remove eyelid lining lesion	10	\$308		
68130		Remove eyelid lining lesion	90	\$642		
68135		Remove eyelid lining lesion	10	\$182		
68200		Treat eyelid by injection	0	\$75		
68320		Revise/graft eyelid lining	90	\$882		
68325		Revise/graft eyelid lining	90	\$1,198		
68326		Revise/graft eyelid lining	90	\$1,124		
68328		Revise/graft eyelid lining	90	\$1,377		
68330		Revise eyelid lining	90	\$767		
68335		Revise/graft eyelid lining	90	\$1,259		
68340		Separate eyelid adhesions	90	\$511		
68360		Revise eyelid lining	90	\$703		
68362		Revise eyelid lining	90	\$1,088		
68371		Harvest eye tissue alograft		\$839		
68399		Eyelid lining surgery		BR		
68400		Incise/drain tear gland	10	\$192		
68420		Incise/drain tear sac	10	\$236		
68440		Incise tear duct opening	10	\$120		
68500		Removal of tear gland	90	\$1,333		
68505		Partial removal tear gland	90	\$1,386		
68510		Biopsy of tear gland	0	\$607		
68520		Removal of tear sac	90	\$1,184		
68525		Biopsy of tear sac	0	\$591		
68530		Clearance of tear duct	10	\$469		
68540		Remove tear gland lesion	90	\$1,339		
68550		Remove tear gland lesion	90	\$1,752		
68700		Repair tear ducts	90	\$640		
68705		Revise tear duct opening	10	\$218		
68720		Create tear sac drain	90	\$1,407		
68745		Create tear duct drain	90	\$1,079		
68750		Create tear duct drain	90	\$1,570		
68760		Close tear duct opening	10	\$187		
68761		Close tear duct opening	10	\$161		
68770		Close tear system fistula	90	\$785		
68801		Dilate tear duct opening	10	\$170		
68810		Probe nasolacrimal duct	10	\$269		
68811		Probe nasolacrimal duct	10	\$298		
68815		Probe nasolacrimal duct	10	\$446		
68816		Probe nl duct w/balloon			\$1,519	\$533
68840		Explore/irrigate tear ducts	10	\$124		
68850		Injection for tear sac X-ray	0	\$96		
68899		Tear duct system surgery		BR		
69000		Drain external ear lesion	10	\$126		

LABOR AND EMPLOYMENT

CPT Code	Mod	Description	Global Days	Maximum Allowance	Non-Facility Maximum	Facility Maximum
69005		Drain external ear lesion	10	\$237		
69020		Drain outer ear canal lesion	10	\$136		
69090		Pierce earlobes		BR		
69100		Biopsy of external ear	0	\$106		
69105		Biopsy of external ear canal	0	\$124		
69110		Partial removal external ear	90	\$449		
69120		Removal of external ear	90	\$340		
69140		Remove ear canal lesion(s)	90	\$1,173		
69145		Remove ear canal lesion(s)	90	\$378		
69150		Extensive ear canal surgery	90	\$1,750		
69155		Extensive ear/neck surgery	90	\$2,447		
69200		Clear outer ear canal	0	\$87		
69205		Clear outer ear canal	10	\$165		
69210		Remove impacted ear wax	0	\$61		
69220		Clean out mastoid cavity	0	\$98		
69222		Clean out mastoid cavity	10	\$154		
69300		Revise external ear			\$1,565	\$1,009
69310		Rebuild outer ear canal	90	\$1,523		
69320		Rebuild outer ear canal	90	\$2,329		
69399		Outer ear surgery procedure		\$0		
69400		Inflate middle ear canal	0	\$94		
69401		Inflate middle ear canal	0	\$65		
69405		Catheterize middle ear canal	10	\$220		
69410		Inset middle ear baffle	0	\$71		
69420		Incision of eardrum	10	\$145		
69421		Incision of eardrum	10	\$209		
69424		Remove ventilating tube	0	\$108		
69433		Create eardrum opening	10	\$209		
69436		Create eardrum opening	10	\$302		
69440		Exploration of middle ear	90	\$1,199		
69450		Eardrum revision	90	\$1,132		
69501		Mastoidectomy	90	\$1,478		
69502		Mastoidectomy	90	\$1,895		
69505		Remove mastoid structures	90	\$2,156		
69511		Extensive mastoid surgery	90	\$2,245		
69530		Extensive mastoid surgery	90	\$2,582		
69535		Remove part of temporal bone	90	\$4,432		
69540		Remove ear lesion	10	\$181		
69550		Remove ear lesion	90	\$2,061		
69552		Remove ear lesion	90	\$2,650		
69554		Remove ear lesion	90	\$3,630		
69601		Mastoid surgery revision	90	\$2,008		
69602		Mastoid surgery revision	90	\$2,208		
69603		Mastoid surgery revision	90	\$2,323		
69604		Mastoid surgery revision	90	\$2,765		
69605		Mastoid surgery revision	90	\$2,467		
69610		Repair of eardrum	10	\$383		
69620		Repair of eardrum	90	\$1,170		
69631		Repair eardrum structures	90	\$1,761		
69632		Rebuild eardrum structures	90	\$2,126		
69633		Rebuild eardrum structures	90	\$2,056		
69635		Repair eardrum structures	90	\$2,237		
69636		Rebuild eardrum structures	90	\$2,551		
69637		Rebuild eardrum structures	90	\$2,565		
69641		Revise middle ear & mastoid	90	\$2,157		
69642		Revise middle ear & mastoid	90	\$2,775		
69643		Revise middle ear & mastoid	90	\$2,672		
69644		Revise middle ear & mastoid	90	\$2,968		
69645		Revise middle ear & mastoid	90	\$2,826		
69646		Revise middle ear & mastoid	90	\$2,953		
69650		Release middle ear bone	90	\$1,610		
69660		Revise middle ear bone	90	\$2,055		
69661		Revise middle ear bone	90	\$2,527		
69662		Revise middle ear bone	90	\$2,478		
69666		Repair middle ear structures	90	\$1,807		
69667		Repair middle ear structures	90	\$1,783		

Title 40, Part I

CPT Code	Mod	Description	Global Days	Maximum Allowance	Non-Facility Maximum	Facility Maximum
69670		Remove mastoid air cells	90	\$1,579		
69676		Remove middle ear nerve	90	\$1,318		
69700		Close mastoid fistula	90	\$1,181		
69710		Implant/replace hearing aid		BR		
69711		Remove/repair hearing aid	90	\$1,345		
69714		Implant temple bone w/stimul		\$2,301		
69715		Temple bone implant w/stimulat		\$2,844		
69717		Temple bone implant revision		\$2,420		
69718		Revise temple bone implant		\$2,874		
69720		Release facial nerve	90	\$2,449		
69725		Release facial nerve	90	\$2,488		
69740		Repair facial nerve	90	\$2,047		
69745		Repair facial nerve	90	\$2,378		
69799		Middle ear surgery procedure		BR		
69801		Incise inner ear.....	90	\$1,388		
69802		Incise inner ear	90	\$1,763		
69805		Explore inner ear	90	\$2,047		
69806		Explore inner ear	90	\$2,450		
69820		Establish inner ear window	90	\$1,415		
69840		Revise inner ear window	90	\$1,349		
69905		Remove inner ear	90	\$2,070		
69910		Remove inner ear & mastoid	90	\$2,541		
69915		Incise inner ear nerve	90	\$2,805		
69930		Implant cochlear device	90	\$3,188		
69949		Inner ear surgery procedure		BR		
69950		Incise inner ear nerve	90	\$2,935		
69955		Release facial nerve	90	\$3,161		
69960		Release inner ear canal	90	\$2,798		
69970		Remove inner ear lesion	90	\$3,133		
69979		Temporal bone surgery		BR		
69990		Microsurgery add-on...		\$424		
70010		Contrast X-ray of brain		\$438		
70010	26	Contrast X-ray of brain		\$127		
70010	TC	Contrast X-ray of brain		\$311		
70015		Contrast X-ray of brain		\$224		
70015	26	Contrast X-ray of brain		\$127		
70015	TC	Contrast X-ray of brain		\$98		
70030		X-ray eye for foreign body		\$49		
70030	26	X-ray eye for foreign body		\$19		
70030	TC	X-ray eye for foreign body		\$31		
70100		X-ray exam of jaw		\$58		
70100	26	X-ray exam of jaw		\$20		
70100	TC	X-ray exam of jaw		\$38		
70110		X-ray exam of jaw		\$73		
70110	26	X-ray exam of jaw		\$28		
70110	TC	X-ray exam of jaw		\$45		
70120		X-ray exam of mastoids		\$65		
70120	26	X-ray exam of mastoids		\$20		
70120	TC	X-ray exam of mastoids		\$45		
70130		X-ray exam of mastoids		\$94		
70130	26	X-ray exam of mastoids		\$37		
70130	TC	X-ray exam of mastoids		\$57		
70134		X-ray exam of middle ear		\$90		
70134	26	X-ray exam of middle ear		\$37		
70134	TC	X-ray exam of middle ear		\$54		
70140		X-ray exam of facial bones		\$66		
70140	26	X-ray exam of facial bones		\$21		
70140	TC	X-ray exam of facial bones		\$45		
70150		X-ray exam of facial bones		\$85		
70150	26	X-ray exam of facial bones		\$28		
70150	TC	X-ray exam of facial bones		\$57		
70160		X-ray exam of nasal bones		\$56		
70160	26	X-ray exam of nasal bones		\$19		
70160	TC	X-ray exam of nasal bones		\$38		
70170		X-ray exam of tear duct		\$101		
70170	26	X-ray exam of tear duct		\$33		

LABOR AND EMPLOYMENT

CPT Code	Mod	Description	Global Days	Maximum Allowance	Non-Facility Maximum	Facility Maximum
70170	TC	X-ray exam of tear duct		\$68		
70190		X-ray exam of eye sockets		\$68		
70190	26	X-ray exam of eye sockets		\$23		
70190	TC	X-ray exam of eye sockets		\$45		
70200		X-ray exam of eye sockets		\$87		
70200	26	X-ray exam of eye sockets		\$31		
70200	TC	X-ray exam of eye sockets		\$57		
70210		X-ray exam of sinuses		\$63		
70210	26	X-ray exam of sinuses		\$19		
70210	TC	X-ray exam of sinuses		\$45		
70220		X-ray exam of sinuses		\$84		
70220	26	X-ray exam of sinuses		\$28		
70220	TC	X-ray exam of sinuses		\$57		
70240		X-ray exam pituitary saddle		\$51		
70240	26	X-ray exam pituitary saddle		\$21		
70240	TC	X-ray exam pituitary saddle		\$31		
70250		X-ray exam of skull		\$71		
70250	26	X-ray exam of skull		\$26		
70250	TC	X-ray exam of skull		\$45		
70260		X-ray exam of skull		\$101		
70260	26	X-ray exam of skull		\$37		
70260	TC	X-ray exam of skull		\$65		
70300		X-ray exam of teeth		\$31		
70300	26	X-ray exam of teeth		\$12		
70300	TC	X-ray exam of teeth		\$19		
70310		X-ray exam of teeth		\$47		
70310	26	X-ray exam of teeth		\$17		
70310	TC	X-ray exam of teeth		\$31		
70320		Full mouth X-ray of teeth		\$81		
70320	26	Full mouth X-ray of teeth		\$24		
70320	TC	Full mouth X-ray of teeth		\$57		
70328		X-ray exam of jaw joint		\$56		
70328	26	X-ray exam of jaw joint		\$20		
70328	TC	X-ray exam of jaw joint		\$36		
70330		X-ray exam of jaw joints		\$87		
70330	26	X-ray exam of jaw joints		\$26		
70330	TC	X-ray exam of jaw joints		\$61		
70332		X-ray exam of jaw joint		\$210		
70332	26	X-ray exam of jaw joint		\$59		
70332	TC	X-ray exam of jaw joint		\$151		
70336		Magnetic image jaw joint		\$906		
70336	26	Magnetic image jaw joint		\$102		
70336	TC	Magnetic image jaw joint		\$804		
70350		X-ray head for orthodontia		\$45		
70350	26	X-ray head for orthodontia		\$19		
70350	TC	X-ray head for orthodontia		\$27		
70355		Panoramic X-ray of jaws		\$63		
70355	26	Panoramic X-ray of jaws		\$21		
70355	TC	Panoramic X-ray of jaws		\$42		
70360		X-ray exam of neck		\$49		
70360	26	X-ray exam of neck		\$19		
70360	TC	X-ray exam of neck		\$31		
70370		Throat X-ray & fluoroscopy		\$128		
70370	26	Throat X-ray & fluoroscopy		\$35		
70370	TC	Throat X-ray & fluoroscopy		\$94		
70371		Speech evaluation, complex		\$241		
70371	26	Speech evaluation, complex		\$91		
70371	TC	Speech evaluation, complex		\$151		
70373		Contrast X-ray of larynx		\$175		
70373	26	Contrast X-ray of larynx		\$47		
70373	TC	Contrast X-ray of larynx		\$129		
70380		X-ray exam of salivary gland		\$67		
70380	26	X-ray exam of salivary gland		\$19		
70380	TC	X-ray exam of salivary gland		\$49		
70390		X-ray exam of salivary duct		\$169		
70390	26	X-ray exam of salivary duct		\$41		



Title 40, Part I

CPT Code	Mod	Description	Global Days	Maximum Allowance	Non-Facility Maximum	Facility Maximum
70390	TC	X-ray exam of salivary duct		\$129		
70450		Cat scan of head or brain		\$430		
70450	26	Cat scan of head or brain		\$91		
70450	TC	Cat scan of head or brain		\$339		
70460		Contrast cat scan of head		\$528		
70460	26	Contrast cat scan of head		\$122		
70460	TC	Contrast cat scan of head		\$406		
70470		Contrast cat scans of head		\$643		
70470	26	Contrast cat scans of head		\$136		
70470	TC	Contrast cat scans of head		\$507		
70480		Cat scan of skull		\$476		
70480	26	Cat scan of skull		\$138		
70480	TC	Cat scan of skull		\$339		
70481		Contrast cat scan of skull		\$554		
70481	26	Contrast cat scan of skull		\$148		
70481	TC	Contrast cat scan of skull		\$406		
70482		Contrast cat scans of skull		\$663		
70482	26	Contrast cat scans of skull		\$156		
70482	TC	Contrast cat scans of skull		\$507		
70486		Cat scan of face, jaw		\$461		
70486	26	Cat scan of face, jaw		\$122		
70486	TC	Cat scan of face, jaw		\$339		
70487		Contrast cat scan, face/jaw		\$545		
70487	26	Contrast cat scan, face/jaw		\$139		
70487	TC	Contrast cat scan, face/jaw		\$406		
70488		Contrast cat scans face/jaw		\$660		
70488	26	Contrast cat scans face/jaw		\$153		
70488	TC	Contrast cat scans face/jaw		\$507		
70490		Cat scan of neck tissue		\$476		
70490	26	Cat scan of neck tissue		\$138		
70490	TC	Cat scan of neck tissue		\$339		
70491		Contrast cat of neck tissue		\$554		
70491	26	Contrast cat of neck tissue		\$148		
70491	TC	Contrast cat of neck tissue		\$406		
70492		Contrast cat of neck tissue		\$663		
70492	26	Contrast cat of neck tissue		\$156		
70492	TC	Contrast cat of neck tissue		\$507		
70496	26	Ct angiography head		\$174		
70496	TC	Ct angiography head		\$881		
70496		Ct angiography head		\$1,055		
70498	26	Ct angiography neck		\$174		
70498	TC	Ct angiography neck		\$919		
70498		Ct angiography neck		\$1,093		
70540		Magnetic image, face, neck		\$963		
70540	26	Magnetic image, face, neck		\$159		
70540	TC	Magnetic image, face, neck		\$804		
70542	26	Mri orbit/face/neck w/dye		\$161		
70542	TC	Mri orbit/face/neck w/dye		\$807		
70542		Mri orbit/face/neck w/dye		\$969		
70543	26	Mri orb/fac/nck w/o & w/dye		\$213		
70543	TC	Mri orb/fac/nck w/o & w/dye		\$966		
70543		Mri orb/fac/nck w/o & w/dye		\$1,180		
70544	26	Mr angiography head w/o dye		\$120		
70544	TC	Mr angiography head w/o dye		\$849		
70544		Mr angiography head w/o dye		\$969		
70545	26	Mr angiography head w/dye		\$119		
70545	TC	Mr angiography head w/dye		\$829		
70545		Mr angiography head w/dye		\$948		
70546	26	Mr angiograph head w/o&w/dye		\$180		
70546	TC	Mr angiograph head w/o&w/dye		\$1,281		
70546		Mr angiograph head w/o&w/dye		\$1,461		
70547	26	Mr angiography neck w/o dye		\$120		
70547	TC	Mr angiography neck w/o dye		\$849		
70547		Mr angiography neck w/o dye		\$968		
70548	26	Mr angiography neck w/dye		\$120		
70548	TC	Mr angiography neck w/dye		\$910		

LABOR AND EMPLOYMENT

CPT Code	Mod	Description	Global Days	Maximum Allowance	Non-Facility Maximum	Facility Maximum
70548		Mr angiography neck w/dye		\$1,030		
70549	26	Mr angiograph neck w/o&w/dye		\$179		
70549	TC	Mr angiograph neck w/o&w/dye		\$1,286		
70549		Mr angiograph neck w/o&w/dye		\$1,465		
70551		Magnetic image, brain		\$963		
70551	26	Magnetic image, brain		\$159		
70551	TC	Magnetic image, brain		\$804		
70552		Magnetic image, brain		\$1,155		
70552	26	Magnetic image, brain		\$192		
70552	TC	Magnetic image, brain		\$964		
70553		Magnetic image, brain		\$2,039		
70553	26	Magnetic image, brain		\$255		
70553	TC	Magnetic image, brain		\$1,785		
70554	26	Fmri brain by tech		\$211		
70554	TC	Fmri brain by tech		\$818		
70554		Fmri brain by tech		\$1,029		
70555		Fmri brain by phys/psych		\$261		
70557		Mri brain w/o dye		\$348		
70558		Mri brain w/dye		\$327		
70559		Mri brain w/o & w/dye		\$330		
71010		Chest x-ray 1 view frontal		\$45		
71010	TC	Chest x-ray 1 view frontal		\$26		
71010	26	Chest x-ray 1 view frontal		\$19		
71015		Chest x-ray stereo frontal		\$56		
71015	TC	Chest x-ray stereo frontal		\$34		
71015	26	Chest x-ray stereo frontal		\$22		
71020		Chest x-ray 2vw frontal&latl		\$56		
71020	TC	Chest x-ray 2vw frontal&latl		\$34		
71020	26	Chest x-ray 2vw frontal&latl		\$22		
71021		Chest x-ray frnt lat lordotc		\$68		
71021	TC	Chest x-ray frnt lat lordotc		\$40		
71021	26	Chest x-ray frnt lat lordotc		\$28		
71022		Chest x-ray frnt lat oblique		\$84		
71022	TC	Chest x-ray frnt lat oblique		\$50		
71022	26	Chest x-ray frnt lat oblique		\$34		
71023		Chest x-ray and fluoroscopy		\$127		
71023	TC	Chest x-ray and fluoroscopy		\$89		
71023	26	Chest x-ray and fluoroscopy		\$39		
71030		Chest x-ray 4/> views		\$84		
71030	TC	Chest x-ray 4/> views		\$51		
71030	26	Chest x-ray 4/> views		\$32		
71034		Chest x-ray&fluoro 4/> views		\$167		
71034	TC	Chest x-ray&fluoro 4/> views		\$119		
71034	26	Chest x-ray&fluoro 4/> views		\$48		
71035		Chest x-ray special views		\$66		
71035	TC	Chest x-ray special views		\$47		
71035	26	Chest x-ray special views		\$19		
71100		X-ray exam ribs uni 2 views		\$66		
71100	TC	X-ray exam ribs uni 2 views		\$43		
71100	26	X-ray exam ribs uni 2 views		\$23		
71101		X-ray exam unilat ribs/chest		\$73		
71101	TC	X-ray exam unilat ribs/chest		\$45		
71101	26	X-ray exam unilat ribs/chest		\$28		
71110		X-ray exam ribs bil 3 views		\$75		
71110	TC	X-ray exam ribs bil 3 views		\$47		
71110	26	X-ray exam ribs bil 3 views		\$28		
71111		X-ray exam ribs/chest4/> vws		\$96		
71111	TC	X-ray exam ribs/chest4/> vws		\$62		
71111	26	X-ray exam ribs/chest4/> vws		\$34		
71120		X-ray exam breastbone 2/>vws		\$59		
71120	TC	X-ray exam breastbone 2/>vws		\$39		
71120	26	X-ray exam breastbone 2/>vws		\$21		
71130		X-ray strenoclavic jt 3/>vws		\$72		
71130	TC	X-ray strenoclavic jt 3/>vws		\$49		
71130	26	X-ray strenoclavic jt 3/>vws		\$23		

Title 40, Part I

CPT Code	Mod	Description	Global Days	Maximum Allowance	Non-Facility Maximum	Facility Maximum
71250		Ct thorax w/o dye		\$363		
71250	TC	Ct thorax w/o dye		\$259		
71250	26	Ct thorax w/o dye		\$104		
71260		Ct thorax w/dye		\$461		
71260	TC	Ct thorax w/dye		\$334		
71260	26	Ct thorax w/dye		\$127		
71270		Ct thorax w/o & w/dye		\$553		
71270	TC	Ct thorax w/o & w/dye		\$413		
71270	26	Ct thorax w/o & w/dye		\$141		
71275		Ct angiography chest		\$836		
71550		Magnetic image, chest		\$976		
71550	26	Magnetic image, chest		\$173		
71550	TC	Magnetic image, chest		\$804		
71551	26	Mri chest w/dye		\$173		
71551	TC	Mri chest w/dye		\$944		
71551		Mri chest w/dye		\$1,117		
71552	26	Mri chest w/o & w/dye		\$224		
71552	TC	Mri chest w/o & w/dye		\$1,165		
71552		Mri chest w/o & w/dye		\$1,389		
71555		Magnetic imaging/chest		\$991		
72020		X-ray exam of spine 1 view		\$44		
72020	TC	X-ray exam of spine 1 view		\$29		
72020	26	X-ray exam of spine 1 view		\$16		
72040		X-ray exam neck spine 2-3 vw		\$66		
72040	TC	X-ray exam neck spine 2-3 vw		\$44		
72040	26	X-ray exam neck spine 2-3 vw		\$23		
72050		X-ray exam neck spine 4/5vws		\$90		
72050	TC	X-ray exam neck spine 4/5vws		\$58		
72050	26	X-ray exam neck spine 4/5vws		\$32		
72052		X-ray exam neck spine 6/>vws		\$113		
72052	TC	X-ray exam neck spine 6/>vws		\$76		
72052	26	X-ray exam neck spine 6/>vws		\$37		
72070		X-ray exam thorac spine 2vws		\$68		
72070	TC	X-ray exam thorac spine 2vws		\$45		
72070	26	X-ray exam thorac spine 2vws		\$23		
72072		X-ray exam thorac spine 3vws		\$69		
72072	TC	X-ray exam thorac spine 3vws		\$47		
72072	26	X-ray exam thorac spine 3vws		\$22		
72074		X-ray exam thorac spine4/>vw		\$79		
72074	TC	X-ray exam thorac spine4/>vw		\$56		
72074	26	X-ray exam thorac spine4/>vw		\$22		
72080		X-ray exam thoracolumb 2/> vw		\$61		
72080	TC	X-ray exam trunk spine 2 vws		\$39		
72080	26	X-ray exam trunk spine 2 vws		\$22		
72081		X-ray exam entire spi 1 vw		\$78		
72081	TC	X-ray exam entire spi 1 vw		\$51		
72081	26	X-ray exam entire spi 1 vw		\$27		
72082		X-ray exam entire spi 2/3 vw		\$125		
72082	TC	X-ray exam entire spi 2/3 vw		\$92		
72082	26	X-ray exam entire spi 2/3 vw		\$33		
72083		X-ray exam entire spi 4/5 vw		\$136		
72083	TC	X-ray exam entire spi 4/5 vw		\$100		
72083	26	X-ray exam entire spi 4/5 vw		\$36		
72084		X-ray exam entire spi 6/> vw		\$162		
72084	TC	X-ray exam entire spi 6/> vw		\$121		
72084	26	X-ray exam entire spi 6/> vw		\$41		
72100		X-ray exam l-s spine 2/3 vws		\$70		
72100	TC	X-ray exam l-s spine 2/3 vws		\$47		
72100	26	X-ray exam l-s spine 2/3 vws		\$23		
72110		X-ray exam l-2 spine 4/>vws		\$98		
72110	TC	X-ray exam l-2 spine 4/>vws		\$66		
72110	26	X-ray exam l-2 spine 4/>vws		\$32		

LABOR AND EMPLOYMENT

CPT Code	Mod	Description	Global Days	Maximum Allowance	Non-Facility Maximum	Facility Maximum
72114		X-ray exam l-s spine bending		\$125		
72114	TC	X-ray exam l-s spine bending		\$92		
72114	26	X-ray exam l-s spine bending		\$34		
72120		X-ray bend only l-s spine		\$81		
72120	TC	X-ray bend only l-s spine		\$58		
72120	26	X-ray bend only l-s spine		\$23		
72125		Ct neck spine w/o dye		\$371		
72125	TC	Ct neck spine w/o dye		\$262		
72125	26	Ct neck spine w/o dye		\$109		
72126		Ct neck spine w/dye		\$460		
72126	TC	Ct neck spine w/dye		\$336		
72126	26	Ct neck spine w/dye		\$124		
72127		Ct neck spine w/o & w/dye		\$545		
72127	TC	Ct neck spine w/o & w/dye		\$415		
72127	26	Ct neck spine w/o & w/dye		\$129		
72128		Ct chest spine w/o dye		\$363		
72128	TC	Ct chest spine w/o dye		\$260		
72128	26	Ct chest spine w/o dye		\$102		
72129		Ct chest spine w/dye		\$461		
72129	TC	Ct chest spine w/dye		\$337		
72129	26	Ct chest spine w/dye		\$124		
72130		Ct chest spine w/o & w/dye		\$548		
72130	TC	Ct chest spine w/o & w/dye		\$419		
72130	26	Ct chest spine w/o & w/dye		\$129		
72131		Ct lumbar spine w/o dye		\$361		
72131	TC	Ct lumbar spine w/o dye		\$259		
72131	26	Ct lumbar spine w/o dye		\$102		
72132		Ct lumbar spine w/dye		\$460		
72132	TC	Ct lumbar spine w/dye		\$335		
72132	26	Ct lumbar spine w/dye		\$124		
72133		Ct lumbar spine w/o & w/dye		\$544		
72133	TC	Ct lumbar spine w/o & w/dye		\$415		
72133	26	Ct lumbar spine w/o & w/dye		\$129		
72141		Mri neck spine w/o dye		\$450		
72141	TC	Mri neck spine w/o dye		\$299		
72141	26	Mri neck spine w/o dye		\$152		
72142		Mri neck spine w/dye		\$654		
72142	TC	Mri neck spine w/dye		\$470		
72142	26	Mri neck spine w/dye		\$183		
72146		Mri chest spine w/o dye		\$450		
72146	TC	Mri chest spine w/o dye		\$299		
72146	26	Mri chest spine w/o dye		\$152		
72147		Mri chest spine w/dye		\$646		
72147	TC	Mri chest spine w/dye		\$465		
72147	26	Mri chest spine w/dye		\$182		
72148		Mri lumbar spine w/o dye		\$448		
72148	TC	Mri lumbar spine w/o dye		\$297		
72148	26	Mri lumbar spine w/o dye		\$152		
72149		Mri lumbar spine w/dye		\$646		
72149	TC	Mri lumbar spine w/dye		\$463		
72149	24	Mri lumbar spine w/dye		\$183		
72156		Mri neck spine w/o & w/dye		\$763		
72156	TC	Mri neck spine w/o & w/dye		\$529		
72156	26	Mri neck spine w/o & w/dye		\$234		
72157		Mri chest spine w/o & w/dye		\$764		
72157	TC	Mri chest spine w/o & w/dye		\$531		
72157	26	Mri chest spine w/o & w/dye		\$234		
72158		Mri lumbar spine w/o & w/dye		\$761		
72158	TC	Mri lumbar spine w/o & w/dye		\$528		
72158	26	Mri lumbar spine w/o & w/dye		\$234		

Title 40, Part I

CPT Code	Mod	Description	Global Days	Maximum Allowance	Non-Facility Maximum	Facility Maximum
72159		MR angio spine w/o&w/dye		\$838		
72159	TC	MR angio spine w/o&w/dye		\$654		
72159	26	MR angio spine w/o&w/dye		\$184		
72170		X-ray exam of pelvis		\$64		
72170	TC	X-ray exam of pelvis		\$46		
72170	26	X-ray exam of pelvis		\$18		
72190		X-ray exam of pelvis		\$77		
72190	TC	X-ray exam of pelvis		\$54		
72190	26	X-ray exam of pelvis		\$22		
72191		Ct angiograph pelv w/o&w/dye		\$885		
72192		Cat scan of pelvis		\$540		
72192	26	Cat scan of pelvis		\$117		
72192	TC	Cat scan of pelvis		\$424		
72193		Contrast cat scan of pelvis		\$614		
72193	26	Contrast cat scan of pelvis		\$124		
72193	TC	Contrast cat scan of pelvis		\$490		
72194		Contrast cat scans of pelvis		\$738		
72194	26	Contrast cat scans of pelvis		\$130		
72194	TC	Contrast cat scans of pelvis		\$609		
72195	26	Mri pelvis w/o dye		\$147		
72195	TC	Mri pelvis w/o dye		\$749		
72195		Mri pelvis w/o dye		\$896		
72196		Magnetic image, pelvis		\$976		
72196	26	Magnetic image, pelvis		\$173		
72196	TC	Magnetic image, pelvis		\$804		
72197	26	Mri pelvis w/o & w/dye		\$224		
72197	TC	Mri pelvis w/o & w/dye		\$987		
72197		Mri pelvis w/o & w/dye		\$1,211		
72198		Magnetic imaging/pelvis(mri)		\$990		
72198	26	Magnetic imaging/pelvis(mri)		\$187		
72198	TC	Magnetic imaging/pelvis(mri)		\$804		
72200		X-ray exam sacroiliac joints		\$56		
72200	26	X-ray exam sacroiliac joints		\$19		
72200	TC	X-ray exam sacroiliac joints		\$38		
72202		X-ray exam sacroiliac joints		\$66		
72202	26	X-ray exam sacroiliac joints		\$21		
72202	TC	X-ray exam sacroiliac joints		\$45		
72220		X-ray exam of tailbone		\$60		
72220	26	X-ray exam of tailbone		\$19		
72220	TC	X-ray exam of tailbone		\$42		
72240		Contrast X-ray of neck spine		\$438		
72240	26	Contrast X-ray of neck spine		\$98		
72240	TC	Contrast X-ray of neck spine		\$341		
72255		Contrast X-ray thorax spine		\$409		
72255	26	Contrast X-ray thorax spine		\$98		
72255	TC	Contrast X-ray thorax spine		\$311		
72265		Contrast X-ray lower spine		\$382		
72265	26	Contrast X-ray lower spine		\$90		
72265	TC	Contrast X-ray lower spine		\$292		
72270		Contrast X-ray of spine		\$579		
72270	26	Contrast X-ray of spine		\$143		
72270	TC	Contrast X-ray of spine		\$437		
72275		Epidurography.....		BR		
72275	26	Epidurography.....		BR		
72275	TC	Epidurography.....		BR		
72285		X-ray c/t spine disk..		\$712		
72285	26	X-ray c/t spine disk..		\$87		
72285	TC	X-ray c/t spine disk..		\$626		
72291		Perq verte/sacroplsty fluor		\$147		
72292		Perq verte/sacroplsty ct		\$149		
72295		X-ray of lower spine disk		\$653		
72295	26	X-ray of lower spine disk		\$90		
72295	TC	X-ray of lower spine disk		\$563		
73000		X-ray exam of collarbone		\$55		
73000	26	X-ray exam of collarbone		\$17		

LABOR AND EMPLOYMENT

CPT Code	Mod	Description	Global Days	Maximum Allowance	Non-Facility Maximum	Facility Maximum
73000	TC	X-ray exam of collarbone		\$38		
73010		X-ray exam of shoulder blade		\$56		
73010	26	X-ray exam of shoulder blade		\$19		
73010	TC	X-ray exam of shoulder blade		\$38		
73020		X-ray exam of shoulder		\$51		
73020	26	X-ray exam of shoulder		\$17		
73020	TC	X-ray exam of shoulder		\$35		
73030		X-ray exam of shoulder		\$61		
73030	26	X-ray exam of shoulder		\$19		
73030	TC	X-ray exam of shoulder		\$42		
73040		Contrast X-ray of shoulder		\$210		
73040	26	Contrast X-ray of shoulder		\$59		
73040	TC	Contrast X-ray of shoulder		\$151		
73050		X-ray exam of shoulders		\$70		
73050	26	X-ray exam of shoulders		\$21		
73050	TC	X-ray exam of shoulders		\$49		
73060		X-ray exam of humerus		\$60		
73060	26	X-ray exam of humerus		\$19		
73060	TC	X-ray exam of humerus		\$42		
73070		X-ray exam of elbow		\$54		
73070	26	X-ray exam of elbow		\$17		
73070	TC	X-ray exam of elbow		\$38		
73080		X-ray exam of elbow		\$60		
73080	26	X-ray exam of elbow		\$19		
73080	TC	X-ray exam of elbow		\$42		
73085		Contrast X-ray of elbow		\$210		
73085	26	Contrast X-ray of elbow		\$59		
73085	TC	Contrast X-ray of elbow		\$151		
73090		X-ray exam of forearm		\$55		
73090	26	X-ray exam of forearm		\$17		
73090	TC	X-ray exam of forearm		\$38		
73092		X-ray exam of arm, infant		\$53		
73092	26	X-ray exam of arm, infant		\$17		
73092	TC	X-ray exam of arm, infant		\$36		
73100		X-ray exam of wrist		\$53		
73100	26	X-ray exam of wrist		\$17		
73100	TC	X-ray exam of wrist		\$36		
73110		X-ray exam of wrist		\$57		
73110	26	X-ray exam of wrist		\$19		
73110	TC	X-ray exam of wrist		\$39		
73115		Contrast X-ray of wrist		\$173		
73115	26	Contrast X-ray of wrist		\$59		
73115	TC	Contrast X-ray of wrist		\$114		
73120		X-ray exam of hand		\$53		
73120	26	X-ray exam of hand		\$17		
73120	TC	X-ray exam of hand		\$36		
73130		X-ray exam of hand		\$57		
73130	26	X-ray exam of hand		\$19		
73130	TC	X-ray exam of hand		\$39		
73140		X-ray exam of finger(s)		\$45		
73140	26	X-ray exam of finger(s)		\$14		
73140	TC	X-ray exam of finger(s)		\$31		
73200		Cat scan of arm		\$472		
73200	26	Cat scan of arm		\$117		
73200	TC	Cat scan of arm		\$356		
73201		Contrast cat scan of arm		\$548		
73201	26	Contrast cat scan of arm		\$124		
73201	TC	Contrast cat scan of arm		\$424		
73202		Contrast cat scans of arm		\$663		
73202	26	Contrast cat scans of arm		\$130		
73202	TC	Contrast cat scans of arm		\$533		
73206	26	Ct angio upr extrm w/o&w/dye		\$179		
73206	TC	Ct angio upr extrm w/o&w/dye		\$578		
73206		Ct angio upr extrm w/o&w/dye		\$757		
73218	26	Mri upper extremity w/o dye		\$135		
73218	TC	Mri upper extremity w/o dye		\$749		

Title 40, Part I

CPT Code	Mod	Description	Global Days	Maximum Allowance	Non-Facility Maximum	Facility Maximum
73218		Mri upper extremity w/o dye		\$884		
73219	26	Mri upper extremity w/dye		\$162		
73219	TC	Mri upper extremity w/dye		\$815		
73219		Mri upper extremity w/dye		\$977		
73220		Magnetic image, arm, hand		\$963		
73220	26	Magnetic image, arm, hand		\$159		
73220	TC	Magnetic image, arm, hand		\$804		
73221		Magnetic image, joint of arm		\$906		
73221	26	Magnetic image, joint of arm		\$102		
73221	TC	Magnetic image, joint of arm		\$804		
73222	26	Mri joint upr extrem w/dye		\$162		
73222	TC	Mri joint upr extrem w/dye		\$749		
73222		Mri joint upr extrem w/dye		\$911		
73223	26	Mri joint upr extr w/o&w/dye		\$215		
73223	TC	Mri joint upr extr w/o&w/dye		\$914		
73223		Mri joint upr extr w/o&w/dye		\$1,129		
73225		Magnetic imaging/upper		\$980		
73225	26	Magnetic imaging/upper		\$177		
73225	TC	Magnetic imaging/upper		\$804		
73500		X-ray exam of hip		\$53		
73500	26	X-ray exam of hip		\$19		
73500	TC	X-ray exam of hip		\$35		
73510		X-ray exam of hip		\$64		
73510	26	X-ray exam of hip		\$23		
73510	TC	X-ray exam of hip		\$42		
73520		X-ray exam of hips		\$77		
73520	26	X-ray exam of hips		\$28		
73520	TC	X-ray exam of hips		\$49		
73525		Contrast X-ray of hip		\$210		
73525	26	Contrast X-ray of hip		\$59		
73525	TC	Contrast X-ray of hip		\$151		
73530		X-ray exam of hip		\$69		
73530	26	X-ray exam of hip		\$31		
73530	TC	X-ray exam of hip		\$38		
73540		X-ray exam of pelvis & hips		\$63		
73540	26	X-ray exam of pelvis & hips		\$22		
73540	TC	X-ray exam of pelvis & hips		\$42		
73550		X-ray exam of thigh		\$60		
73550	26	X-ray exam of thigh		\$19		
73550	TC	X-ray exam of thigh		\$42		
73560		X-ray exam of knee, 1 or 2		\$56		
73560	26	X-ray exam of knee, 1 or 2		\$18		
73560	TC	X-ray exam of knee, 1 or 2		\$39		
73562		X-ray exam of knee, 3		\$62		
73562	26	X-ray exam of knee, 3		\$20		
73562	TC	X-ray exam of knee, 3		\$43		
73564		X-ray exam, knee, 4 or more		\$70		
73564	26	X-ray exam, knee, 4 or more		\$24		
73564	TC	X-ray exam, knee, 4 or more		\$46		
73565		X-ray exam of knee		\$54		
73565	26	X-ray exam of knee		\$18		
73565	TC	X-ray exam of knee		\$36		
73580		Contrast X-ray of knee joint		\$248		
73580	26	Contrast X-ray of knee joint		\$59		
73580	TC	Contrast X-ray of knee joint		\$189		
73590		X-ray exam of lower leg		\$56		
73590	26	X-ray exam of lower leg		\$18		
73590	TC	X-ray exam of lower leg		\$38		
73592		X-ray exam of leg, infant		\$53		
73592	26	X-ray exam of leg, infant		\$17		
73592	TC	X-ray exam of leg, infant		\$36		
73600		X-ray exam of ankle		\$53		
73600	26	X-ray exam of ankle		\$17		
73600	TC	X-ray exam of ankle		\$36		
73610		X-ray exam of ankle		\$57		
73610	26	X-ray exam of ankle		\$19		

LABOR AND EMPLOYMENT

CPT Code	Mod	Description	Global Days	Maximum Allowance	Non-Facility Maximum	Facility Maximum
73610	TC	X-ray exam of ankle		\$39		
73615		Contrast X-ray of ankle		\$210		
73615	26	Contrast X-ray of ankle		\$59		
73615	TC	Contrast X-ray of ankle		\$151		
73620		X-ray exam of foot		\$53		
73620	26	X-ray exam of foot		\$17		
73620	TC	X-ray exam of foot		\$36		
73630		X-ray exam of foot		\$57		
73630	26	X-ray exam of foot		\$19		
73630	TC	X-ray exam of foot		\$39		
73650		X-ray exam of heel		\$52		
73650	26	X-ray exam of heel		\$17		
73650	TC	X-ray exam of heel		\$35		
73660		X-ray exam of toe(s)..		\$45		
73660	26	X-ray exam of toe(s)..		\$14		
73660	TC	X-ray exam of toe(s)..		\$31		
73700		Cat scan of leg		\$472		
73700	26	Cat scan of leg		\$117		
73700	TC	Cat scan of leg		\$356		
73701		Contrast cat scan of leg		\$548		
73701	26	Contrast cat scan of leg		\$124		
73701	TC	Contrast cat scan of leg		\$424		
73702		Contrast cat scans of leg		\$663		
73702	26	Contrast cat scans of leg		\$130		
73702	TC	Contrast cat scans of leg		\$533		
73706	26	Ct angio lwr extr w/o&w/dye		\$189		
73706	TC	Ct angio lwr extr w/o&w/dye		\$656		
73706		Ct angio lwr extr w/o&w/dye		\$845		
73718	26	Mri lower extremity w/o dye		\$135		
73718	TC	Mri lower extremity w/o dye		\$739		
73718		Mri lower extremity w/o dye		\$874		
73719	26	Mri lower extremity w/dye		\$162		
73719	TC	Mri lower extremity w/dye		\$824		
73719		Mri lower extremity w/dye		\$986		
73720		Magnetic image, leg, foot		\$963		
73720	26	Magnetic image, leg, foot		\$159		
73720	TC	Magnetic image, leg, foot		\$804		
73721		Magnetic image, joint of leg		\$906		
73721	26	Magnetic image, joint of leg		\$102		
73721	TC	Magnetic image, joint of leg		\$804		
73722	26	Mri joint of lwr extr w/dye		\$164		
73722	TC	Mri joint of lwr extr w/dye		\$774		
73722		Mri joint of lwr extr w/dye		\$937		
73723	26	Mri joint lwr extr w/o&w/dye		\$214		
73723	TC	Mri joint lwr extr w/o&w/dye		\$919		
73723		Mri joint lwr extr w/o&w/dye		\$1,133		
73725		Magnetic imaging/lower (MRI)		\$987		
73725	26	Magnetic imaging/lower (MRI)		\$183		
73725	TC	Magnetic imaging/lower (MRI)		\$804		
74000		X-ray exam of abdomen		\$57		
74000	26	X-ray exam of abdomen		\$19		
74000	TC	X-ray exam of abdomen		\$38		
74010		X-ray exam of abdomen		\$67		
74010	26	X-ray exam of abdomen		\$26		
74010	TC	X-ray exam of abdomen		\$42		
74020		X-ray exam of abdomen		\$75		
74020	26	X-ray exam of abdomen		\$30		
74020	TC	X-ray exam of abdomen		\$45		
74022		X-ray exam series, abdomen		\$88		
74022	26	X-ray exam series, abdomen		\$35		
74022	TC	X-ray exam series, abdomen		\$54		
74150		Cat scan of abdomen		\$533		
74150	26	Cat scan of abdomen		\$127		
74150	TC	Cat scan of abdomen		\$406		
74160		Contrast cat scan of abdomen		\$626		
74160	26	Contrast cat scan of abdomen		\$136		



Title 40, Part I

CPT Code	Mod	Description	Global Days	Maximum Allowance	Non-Facility Maximum	Facility Maximum
74160	TC	Contrast cat scan of abdomen		\$490		
74170		Contrast cat scans, abdomen		\$759		
74170	26	Contrast cat scans, abdomen		\$151		
74170	TC	Contrast cat scans, abdomen		\$609		
74174	26	Ct angio abd&pelv w/o&w/dye		\$220		
74174	TC	Ct angio abd&pelv w/o&w/dye		\$936		
74174		Ct angio abd&pelv w/o&w/dye		\$1,156		
74175	26	Ct angio abdom w/o & w/dye		\$190		
74175	TC	Ct angio abdom w/o & w/dye		\$752		
74175		Ct angio abdom w/o & w/dye		\$941		
74176	26	Ct abd & pelvis		\$174		
74176	TC	Ct abd & pelvis		\$293		
74176		Ct abd & pelvis		\$467		
74177	26	Ct abd & pelv w/contrast		\$181		
74177	TC	Ct abd & pelv w/contrast		\$555		
74177		Ct abd & pelv w/contrast		\$736		
74178	26	Ct abd & pelv 1/> regns		\$201		
74178	TC	Ct abd & pelv 1/> regns		\$733		
74178		Ct abd & pelv 1/> regns		\$935		
74181		Magnetic image, abdomen (MRI)		\$976		
74181	26	Magnetic image, abdomen (MRI)		\$173		
74181	TC	Magnetic image, abdomen (MRI)		\$804		
74182	26	Mri abdomen w/dye		\$172		
74182	TC	Mri abdomen w/dye		\$918		
74182		Mri abdomen w/dye		\$1,090		
74183	26	Mri abdomen w/o & w/dye		\$224		
74183	TC	Mri abdomen w/o & w/dye		\$991		
74183		Mri abdomen w/o & w/dye		\$1,215		
74185		Magnetic image, abdomen (MRI)		\$990		
74185	26	Magnetic image, abdomen (MRI)		\$187		
74185	TC	Magnetic image, abdomen (MRI)		\$804		
74190		X-ray exam of peritoneum		\$126		
74190	26	X-ray exam of peritoneum		\$33		
74190	TC	X-ray exam of peritoneum		\$94		
74210		Contrast X-ray exam of throat		\$123		
74210	26	Contrast X-ray exam of throat		\$38		
74210	TC	Contrast X-ray exam of throat		\$85		
74220		Contrast X-ray exam, esophagus		\$135		
74220	26	Contrast X-ray exam, esophagus		\$50		
74220	TC	Contrast X-ray exam, esophagus		\$85		
74230		Cinema X-ray throat/esophagus		\$152		
74230	26	Cinema X-ray throat/esophagus		\$59		
74230	TC	Cinema X-ray throat/esophagus		\$94		
74235		Remove esophagus obstruction		\$316		
74235	26	Remove esophagus obstruction		\$127		
74235	TC	Remove esophagus obstruction		\$189		
74240		X-ray exam upper gi tract		\$180		
74240	26	X-ray exam upper gi tract		\$75		
74240	TC	X-ray exam upper gi tract		\$105		
74241		X-ray exam upper gi tract		\$182		
74241	26	X-ray exam upper gi tract		\$75		
74241	TC	X-ray exam upper gi tract		\$108		
74245		X-ray exam upper gi tract		\$269		
74245	26	X-ray exam upper gi tract		\$98		
74245	TC	X-ray exam upper gi tract		\$172		
74246		Contrast X-ray upper gi tract		\$194		
74246	26	Contrast X-ray upper gi tract		\$75		
74246	TC	Contrast X-ray upper gi tract		\$119		
74247		Contrast X-ray upper gi tract		\$196		
74247	26	Contrast X-ray upper gi tract		\$75		
74247	TC	Contrast X-ray upper gi tract		\$122		
74249		Contrast X-ray upper gi tract		\$283		
74249	26	Contrast X-ray upper gi tract		\$98		
74249	TC	Contrast X-ray upper gi tract		\$185		
74250		X-ray exam of small bowel		\$144		
74250	26	X-ray exam of small bowel		\$51		

LABOR AND EMPLOYMENT

CPT Code	Mod	Description	Global Days	Maximum Allowance	Non-Facility Maximum	Facility Maximum
74250	TC	X-ray exam of small bowel		\$94		
74251		X-ray exam of small bowel		\$144		
74251	26	X-ray exam of small bowel		\$51		
74251	TC	X-ray exam of small bowel		\$94		
74260		X-ray exam of small bowel		\$161		
74260	26	X-ray exam of small bowel		\$54		
74260	TC	X-ray exam of small bowel		\$108		
74261	26	Ct colonography dx		\$239		
74261	TC	Ct colonography dx		\$874		
74261		Ct colonography dx		\$1,113		
74262	26	Ct colonography dx w/dye		\$254		
74262	TC	Ct colonography dx w/dye		\$1,045		
74262		Ct colonography dx w/dye		\$1,298		
74263	26	Ct colonography screening		\$236		
74263	TC	Ct colonography screening		\$1,426		
74263		Ct colonography screening		\$1,662		
74270		Contrast X-ray exam of colon		\$198		
74270	26	Contrast X-ray exam of colon		\$75		
74270	TC	Contrast X-ray exam of colon		\$123		
74280		Contrast X-ray exam of colon		\$267		
74280	26	Contrast X-ray exam of colon		\$107		
74280	TC	Contrast X-ray exam of colon		\$161		
74283		Contrast X-ray exam of colon		\$402		
74283	26	Contrast X-ray exam of colon		\$210		
74283	TC	Contrast X-ray exam of colon		\$192		
74290		Contrast X-ray, gallbladder		\$88		
74290	26	Contrast X-ray, gallbladder		\$35		
74290	TC	Contrast X-ray, gallbladder		\$54		
74291		Contrast X-ray, gallbladder		\$52		
74291	26	Contrast X-ray, gallbladder		\$21		
74291	TC	Contrast X-ray, gallbladder		\$31		
74300		X-ray bile ducts, pancreas		\$47		
74300	26	X-ray bile ducts, pancreas		\$39		
74300	TC	X-ray bile ducts, pancreas		BR		
74301		X-rays at surgery add- on		BR		
74301	26	X-rays at surgery add- on		\$22		
74301	TC	X-rays at surgery add- on		BR		
74305		X-ray bile ducts, pancreas		\$102		
74305	26	X-ray bile ducts, pancreas		\$45		
74305	TC	X-ray bile ducts, pancreas		\$57		
74320		Contrast X-ray of bile ducts		\$285		
74320	26	Contrast X-ray of bile ducts		\$59		
74320	TC	Contrast x-ray of bile ducts		\$226		
74327		X-ray for bile stone removal		\$203		
74327	26	X-ray for bile stone removal		\$76		
74327	TC	X-ray for bile stone removal		\$127		
74328		Xray for bile duct endoscopy		\$301		
74328	26	Xray for bile duct endoscopy		\$76		
74328	TC	Xray for bile duct endoscopy		\$226		
74329		X-ray for pancreas endoscopy		\$301		
74329	26	X-ray for pancreas endoscopy		\$76		
74329	TC	X-ray for pancreas endoscopy		\$226		
74330		Xray,bile/pancreas endoscopy		\$301		
74330	26	Xray,bile/pancreas endoscopy		\$76		
74330	TC	Xray,bile/pancreas endoscopy		\$226		
74340		X-ray guide for gi tube		\$248		
74340	26	X-ray guide for gi tube		\$59		
74340	TC	X-ray guide for gi tube		\$189		
74355		X-ray guide, intestinal tube		\$271		
74355	26	X-ray guide, intestinal tube		\$82		
74355	TC	X-ray guide, intestinal tube		\$189		
74360		X-ray guide, gi dilation		\$285		
74360	26	X-ray guide, gi dilation		\$59		
74360	TC	X-ray guide, gi dilation		\$226		
74363		X-ray, bile duct dilation		\$532		
74363	26	X-ray, bile duct dilation		\$95		

Title 40, Part I

CPT Code	Mod	Description	Global Days	Maximum Allowance	Non-Facility Maximum	Facility Maximum
74363	TC	X-ray, bile duct dilation		\$437		
74400		Contrast X-ray urinary tract		\$174		
74400	26	Contrast X-ray urinary tract		\$53		
74400	TC	Contrast X-ray urinary tract		\$122		
74410		Contrast X-ray urinary tract		\$193		
74410	26	Contrast X-ray urinary tract		\$53		
74410	TC	Contrast X-ray urinary tract		\$140		
74415		Contrast X-ray urinary tract		\$205		
74415	26	Contrast X-ray urinary tract		\$53		
74415	TC	Contrast X-ray urinary tract		\$152		
74420		Contrast X-ray urinary tract		\$227		
74420	26	Contrast X-ray urinary tract		\$38		
74420	TC	Contrast X-ray urinary tract		\$189		
74425		Contrast X-ray urinary tract		\$131		
74425	26	Contrast X-ray urinary tract		\$38		
74425	TC	Contrast X-ray urinary tract		\$94		
74430		Contrast X-ray of bladder		\$110		
74430	26	Contrast X-ray of bladder		\$35		
74430	TC	Contrast X-ray of bladder		\$76		
74440		X-ray exam male genital tract		\$122		
74440	26	X-ray exam male genital tract		\$41		
74440	TC	X-ray exam male genital tract		\$82		
74445		X-ray exam of penis		\$203		
74445	26	X-ray exam of penis		\$122		
74445	TC	X-ray exam of penis		\$82		
74450		X-ray exam urethra/bladder		\$140		
74450	26	X-ray exam urethra/bladder		\$35		
74450	TC	X-ray exam urethra/bladder		\$105		
74455		X-ray exam urethra/bladder		\$149		
74455	26	X-ray exam urethra/bladder		\$35		
74455	TC	X-ray exam urethra/bladder		\$114		
74470		X-ray exam of kidney lesion		\$149		
74470	26	X-ray exam of kidney lesion		\$59		
74470	TC	X-ray exam of kidney lesion		\$90		
74475		X-ray control catheter insert		\$351		
74475	26	X-ray control catheter insert		\$59		
74475	TC	X-ray control catheter insert		\$292		
74480		X-ray control catheter insert		\$351		
74480	26	X-ray control catheter insert		\$59		
74480	TC	X-ray control catheter insert		\$292		
74485		X-ray guide, gu dilation		\$285		
74485	26	X-ray guide, gu dilation		\$59		
74485	TC	X-ray guide, gu dilation		\$226		
74710		X-ray measurement of		\$112		
74710	26	X-ray measurement of		\$37		
74710	TC	X-ray measurement of		\$76		
74740		X-ray female genital tract		\$134		
74740	26	X-ray female genital tract		\$41		
74740	TC	X-ray female genital tract		\$94		
74742		X-ray fallopian tube		\$290		
74742	26	X-ray fallopian tube		\$64		
74742	TC	X-ray fallopian tube		\$226		
74775		X-ray exam of perineum		\$173		
74775	26	X-ray exam of perineum		\$68		
74775	TC	X-ray exam of perineum		\$105		
75557	26	Cardiac mri for morph		\$234		
75557	TC	Cardiac mri for morph		\$534		
75557		Cardiac mri for morph		\$768		
75559	26	Cardiac mri w/stress img		\$291		
75559	TC	Cardiac mri w/stress img		\$770		
75559		Cardiac mri w/stress img		\$1,062		
75561	26	Cardiac mri for morph w/dye		\$258		
75561	TC	Cardiac mri for morph w/dye		\$768		
75561		Cardiac mri for morph w/dye		\$1,026		
75563	26	Card mri w/stress img & dye		\$298		
75563	TC	Card mri w/stress img & dye		\$916		

LABOR AND EMPLOYMENT

CPT Code	Mod	Description	Global Days	Maximum Allowance	Non-Facility Maximum	Facility Maximum
75563		Card mri w/stress img & dye		\$1,214		
75565	26	Card mri veloc flow mapping		\$25		
75565	TC	Card mri veloc flow mapping		\$111		
75565		Card mri veloc flow mapping		\$136		
75571	26	Ct hrt w/o dye w/ca test		\$57		
75571	TC	Ct hrt w/o dye w/ca test		\$179		
75571		Ct hrt w/o dye w/ca test		\$235		
75572	26	Ct hrt w/3d image		\$172		
75572	TC	Ct hrt w/3d image		\$473		
75572		Ct hrt w/3d image		\$645		
75573	26	Ct hrt w/3d image congen		\$252		
75573	TC	Ct hrt w/3d image congen		\$634		
75573		Ct hrt w/3d image congen		\$886		
75574	26	Ct angio hrt w/3d image		\$237		
75574	TC	Ct angio hrt w/3d image		\$719		
75574		Ct angio hrt w/3d image		\$956		
75600		Contrast X-ray exam of		\$956		
75600	26	Contrast X-ray exam of		\$53		
75600	TC	Contrast X-ray exam of		\$903		
75605		Contrast X-ray exam of		\$1,025		
75605	26	Contrast X-ray exam of		\$122		
75605	TC	Contrast X-ray exam of		\$903		
75625		Contrast X-ray exam of		\$1,025		
75625	26	Contrast X-ray exam of		\$122		
75625	TC	Contrast X-ray exam of		\$903		
75630		X-ray aorta, leg arteries		\$1,082		
75630	26	X-ray aorta, leg arteries		\$140		
75630	TC	X-ray aorta, leg arteries		\$942		
75635	26	Ct angio abdominal arteries		\$238		
75635	TC	Ct angio abdominal arteries		\$689		
75635		Ct angio abdominal arteries		\$927		
75650		Artery X-rays, head & neck		\$1,063		
75650	26	Artery X-rays, head & neck		\$160		
75650	TC	Artery X-rays, head & neck		\$903		
75658		X-ray exam of arm arteries		\$1,043		
75658	26	X-ray exam of arm arteries		\$140		
75658	TC	X-ray exam of arm arteries		\$903		
75660		Artery X-rays, head & neck		\$1,043		
75660	26	Artery X-rays, head & neck		\$140		
75660	TC	Artery X-rays, head & neck		\$903		
75662		Artery X-rays, head & neck		\$1,081		
75662	26	Artery X-rays, head & neck		\$178		
75662	TC	Artery X-rays, head & neck		\$903		
75665		Artery X-rays, head & neck		\$1,043		
75665	26	Artery X-rays, head & neck		\$140		
75665	TC	Artery X-rays, head & neck		\$903		
75671		Artery X-rays, head & neck		\$1,081		
75671	26	Artery X-rays, head & neck		\$178		
75671	TC	Artery X-rays, head & neck		\$903		
75676		Artery X-rays, neck		\$1,043		
75676	26	Artery X-rays, neck		\$140		
75676	TC	Artery X-rays, neck		\$903		
75680		Artery X-rays, neck		\$1,081		
75680	26	Artery X-rays, neck		\$178		
75680	TC	Artery X-rays, neck		\$903		
75685		Artery X-rays, spine		\$1,043		
75685	26	Artery X-rays, spine		\$140		
75685	TC	Artery X-rays, spine		\$903		
75705		Artery X-rays, spine		\$1,137		
75705	26	Artery X-rays, spine		\$234		
75705	TC	Artery X-rays, spine		\$903		
75710		Artery X-rays, arm/leg		\$1,025		
75710	26	Artery X-rays, arm/leg		\$122		
75710	TC	Artery X-rays, arm/leg		\$903		
75716		Artery X-rays, arms/legs		\$1,043		
75716	26	Artery X-rays, arms/legs		\$140		

Title 40, Part I

CPT Code	Mod	Description	Global Days	Maximum Allowance	Non-Facility Maximum	Facility Maximum
75716	TC	Artery X-rays, arms/legs		\$903		
75726		Artery X-rays, abdomen		\$1,025		
75726	26	Artery X-rays, abdomen		\$122		
75726	TC	Artery X-rays, abdomen		\$903		
75731		Artery X-rays, adrenal		\$1,025		
75731	26	Artery X-rays, adrenal		\$122		
75731	TC	Artery X-rays, adrenal		\$903		
75733		Artery X-rays,adrenal		\$1,043		
75733	26	Artery X-rays,adrenal		\$140		
75733	TC	Artery X-rays,adrenal		\$903		
75736		Artery X-rays, pelvis		\$1,025		
75736	26	Artery X-rays, pelvis		\$122		
75736	TC	Artery X-rays, pelvis		\$903		
75741		Artery X-rays, lung		\$1,043		
75741	26	Artery X-rays, lung		\$140		
75741	TC	Artery X-rays, lung		\$903		
75743		Artery X-rays, lungs		\$1,081		
75743	26	Artery X-rays, lungs		\$178		
75743	TC	Artery X-rays, lungs		\$903		
75746		Artery X-rays, lung		\$1,025		
75746	26	Artery X-rays, lung		\$122		
75746	TC	Artery X-rays, lung		\$903		
75756		Artery X-rays, chest		\$1,025		
75756	26	Artery X-rays, chest		\$122		
75756	TC	Artery X-rays, chest		\$903		
75774		Artery X-ray, each vessel		\$977		
75774	26	Artery X-ray, each vessel		\$37		
75774	TC	Artery X-ray, each vessel		\$940		
75791	26	Av dialysis shunt imaging		\$168		
75791	TC	Av dialysis shunt imaging		\$532		
75791		Av dialysis shunt imaging		\$700		
75801		Lymph vessel X-ray, arm/leg		\$476		
75801	26	Lymph vessel X-ray, arm/leg		\$87		
75801	TC	Lymph vessel X-ray, arm/leg		\$389		
75803		Lymph vessel X-ray, arm/leg		\$514		
75803	26	Lymph vessel X-ray, arm/leg		\$125		
75803	TC	Lymph vessel X-ray, arm/leg		\$389		
75805		Lymph vessel X-ray, trunk		\$524		
75805	26	Lymph vessel X-ray, trunk		\$87		
75805	TC	Lymph vessel X-ray, trunk		\$437		
75807		Lymph vessel X-ray, trunk		\$562		
75807	26	Lymph vessel X-ray, trunk		\$125		
75807	TC	Lymph vessel X-ray, trunk		\$437		
75809		Nonvascular shunt, X-ray		\$106		
75809	26	Nonvascular shunt, X-ray		\$49		
75809	TC	Nonvascular shunt, X-ray		\$57		
75810		Vein X-ray, spleen/liver		\$1,025		
75810	26	Vein X-ray, spleen/liver		\$122		
75810	TC	Vein X-ray, spleen/liver		\$903		
75820		Vein X-ray, arm/leg		\$144		
75820	26	Vein X-ray, arm/leg		\$76		
75820	TC	Vein X-ray, arm/leg		\$68		
75822		Vein X-ray, arms/legs		\$220		
75822	26	Vein X-ray, arms/legs		\$114		
75822	TC	Vein X-ray, arms/legs		\$107		
75825		Vein X-ray, trunk		\$1,025		
75825	26	Vein X-ray, trunk		\$122		
75825	TC	Vein X-ray, trunk		\$903		
75827		Vein X-ray, chest		\$1,025		
75827	26	Vein X-ray, chest		\$122		
75827	TC	Vein X-ray, chest		\$903		
75831		Vein X-ray, kidney		\$1,025		
75831	26	Vein X-ray, kidney		\$122		
75831	TC	Vein X-ray, kidney		\$903		
75833		Vein X-ray, kidneys		\$1,063		
75833	26	Vein X-ray, kidneys		\$160		

LABOR AND EMPLOYMENT

CPT Code	Mod	Description	Global Days	Maximum Allowance	Non-Facility Maximum	Facility Maximum
75833	TC	Vein X-ray, kidneys		\$903		
75840		Vein X-ray, adrenal gland		\$1,025		
75840	26	Vein X-ray, adrenal gland		\$122		
75840	TC	Vein X-ray, adrenal gland		\$903		
75842		Vein X-ray, adrenal glands		\$1,063		
75842	26	Vein X-ray, adrenal glands		\$160		
75842	TC	Vein X-ray, adrenal glands		\$903		
75860		Vein X-ray, neck		\$1,025		
75860	26	Vein X-ray, neck		\$122		
75860	TC	Vein X-ray, neck		\$903		
75870		Vein X-ray, skull		\$1,025		
75870	26	Vein X-ray, skull		\$122		
75870	TC	Vein X-ray, skull		\$903		
75872		Vein X-ray, skull		\$1,025		
75872	26	Vein X-ray, skull		\$122		
75872	TC	Vein X-ray, skull		\$903		
75880		Vein X-ray, eye socket		\$144		
75880	26	Vein X-ray, eye socket		\$76		
75880	TC	Vein X-ray, eye socket		\$68		
75885		Vein X-ray, liver		\$1,058		
75885	26	Vein X-ray, liver		\$155		
75885	TC	Vein X-ray, liver		\$903		
75887		Vein X-ray, liver		\$1,058		
75887	26	Vein X-ray, liver		\$155		
75887	TC	Vein X-ray, liver		\$903		
75889		Vein X-ray, liver		\$1,025		
75889	26	Vein X-ray, liver		\$122		
75889	TC	Vein X-ray, liver		\$903		
75891		Vein X-ray, liver		\$1,025		
75891	26	Vein X-ray, liver		\$122		
75891	TC	Vein X-ray, liver		\$903		
75893		Venous sampling by catheter		\$962		
75893	26	Venous sampling by catheter		\$59		
75893	TC	Venous sampling by catheter		\$903		
75894		X-rays, transcatheter therapy		\$1,871		
75894	26	X-rays, transcatheter therapy		\$140		
75894	TC	X-rays, transcatheter therapy		\$1,731		
75896		X-rays, transcatheter therapy		\$1,644		
75896	26	X-rays, transcatheter therapy		\$140		
75896	TC	X-rays, transcatheter therapy		\$1,504		
75898		Follow-up angiogram		\$253		
75898	26	Follow-up angiogram		\$178		
75898	TC	Follow-up angiogram		\$76		
75900		Arterial catheter exchange		\$1,540		
75900	26	Arterial catheter exchange		\$53		
75900	TC	Arterial catheter exchange		\$1,488		
75901	26	Remove cva device obstruct		\$49		
75901	TC	Remove cva device obstruct		\$321		
75901		Remove cva device obstruct		\$370		
75902	26	Remove cva lumen obstruct		\$40		
75902	TC	Remove cva lumen obstruct		\$121		
75902		Remove cva lumen obstruct		\$160		
75945		Intravascular us.....		\$385		
75945	26	Intravascular us.....		\$45		
75945	TC	Intravascular us.....		\$341		
75946		Intravascular us add- on		\$216		
75946	26	Intravascular us add- on		\$45		
75946	TC	Intravascular us add- on		\$171		
75952		Endovasc repair abdom aorta		\$474		
75953		Abdom aneurysm endovas rpr		\$144		
75954		Iliac aneurysm endovas rpr		\$236		
75956		Xray endovasc thor ao repr		\$741		
75957		Xray endovasc thor ao repr		\$635		
75958		Xray place prox ext thor ao		\$424		
75959		Xray place dist ext thor ao		\$368		
75960		Transcatheter intro, stent		\$1,156		

Title 40, Part I

CPT Code	Mod	Description	Global Days	Maximum Allowance	Non-Facility Maximum	Facility Maximum
75960	26	Transcatheter intro, stent		\$89		
75960	TC	Transcatheter intro, stent		\$1,068		
75961		Retrieval, broken catheter		\$1,208		
75961	26	Retrieval, broken catheter		\$455		
75961	TC	Retrieval, broken catheter		\$753		
75962		Repair arterial blockage		\$1,188		
75962	26	Repair arterial blockage		\$59		
75962	TC	Repair arterial blockage		\$1,129		
75964		Repair artery blockage, each		\$664		
75964	26	Repair artery blockage, each		\$38		
75964	TC	Repair artery blockage, each		\$626		
75966		Repair artery blockage, each		\$1,269		
75966	26	Repair artery blockage, each		\$140		
75966	TC	Repair artery blockage, each		\$1,129		
75968		Repair artery blockage, each		\$664		
75968	26	Repair artery blockage, each		\$38		
75968	TC	Repair artery blockage, each		\$626		
75970		Vascular biopsy		\$917		
75970	26	Vascular biopsy		\$90		
75970	TC	Vascular biopsy		\$828		
75978		Repair venous blockage		\$1,204		
75978	26	Repair venous blockage		\$76		
75978	TC	Repair venous blockage		\$1,129		
75980		Contrast X-ray exam bile duct		\$544		
75980	26	Contrast X-ray exam bile duct		\$155		
75980	TC	Contrast X-ray exam bile duct		\$389		
75982		Contrast X-ray exam bile duct		\$592		
75982	26	Contrast X-ray exam bile duct		\$155		
75982	TC	Contrast X-ray exam bile duct		\$437		
75984		X-ray control catheter change		\$218		
75984	26	X-ray control catheter change		\$78		
75984	TC	X-ray control catheter change		\$140		
75989		Abscess drainage under X-ray		\$358		
75989	26	Abscess drainage under X-ray		\$122		
75989	TC	Abscess drainage under X-ray		\$235		
76000		Fluoroscope examination		\$115		
76000	26	Fluoroscope examination		\$18		
76000	TC	Fluoroscope examination		\$97		
76001		Fluoroscope exam, extensive		\$262		
76001	26	Fluoroscope exam, extensive		\$73		
76001	TC	Fluoroscope exam, extensive		\$189		
76010		X-ray, nose to rectum		\$57		
76010	26	X-ray, nose to rectum		\$19		
76010	TC	X-ray, nose to rectum		\$38		
76080		X-ray exam of fistula		\$135		
76080	26	X-ray exam of fistula		\$57		
76080	TC	X-ray exam of fistula		\$79		
76098		X-ray exam, breast specimen		\$47		
76098	26	X-ray exam, breast specimen		\$17		
76098	TC	X-ray exam, breast specimen		\$31		
76100		X-ray exam of body section		\$153		
76100	26	X-ray exam of body section		\$63		
76100	TC	X-ray exam of body section		\$90		
76101		Complex body section X-ray		\$165		
76101	26	Complex body section X-ray		\$63		
76101	TC	Complex body section X-ray		\$102		
76102		Complex body section X-ray		\$188		
76102	26	Complex body section X-ray		\$63		
76102	TC	Complex body section X-ray		\$125		
76120		Cinematic X-rays		\$117		
76120	26	Cinematic X-rays		\$41		
76120	TC	Cinematic X-rays		\$76		
76125		Cinematic X-rays add- on		\$87		
76125	26	Cinematic X-rays add- on		\$29		
76125	TC	Cinematic X-rays add- on		\$59		
76140		X-ray consultation		BR		

LABOR AND EMPLOYMENT

CPT Code	Mod	Description	Global Days	Maximum Allowance	Non-Facility Maximum	Facility Maximum
76376	26	3d render w/o postprocess		\$20		
76376	TC	3d render w/o postprocess		\$103		
76376		3d render w/o postprocess		\$122		
76377	26	3d rendering w/postprocess		\$79		
76377	TC	3d rendering w/postprocess		\$85		
76377		3d rendering w/postprocess		\$164		
76380		Cat scan follow-up study		\$357		
76380	26	Cat scan follow-up study		\$105		
76380	TC	Cat scan follow-up study		\$252		
76390		Mr spectroscopy.....		\$986		
76390	26	Mr spectroscopy.....		\$150		
76390	TC	Mr spectroscopy.....		\$836		
76499		Radiographic procedure		BR		
76499	26	Radiographic procedure		BR		
76499	TC	Radiographic procedure		BR		
76506		Echo exam of head		\$170		
76506	26	Echo exam of head		\$68		
76506	TC	Echo exam of head		\$102		
76510	26	Ophth us b & quant a		\$197		
76510	TC	Ophth us b & quant a		\$164		
76510		Ophth us b & quant a		\$361		
76511		Echo exam of eye		\$177		
76511	26	Echo exam of eye		\$87		
76511	TC	Echo exam of eye		\$90		
76512		Echo exam of eye		\$182		
76512	26	Echo exam of eye		\$72		
76512	TC	Echo exam of eye		\$110		
76513		Echo exam of eye, water bath		\$186		
76513	26	Echo exam of eye, water bath		\$72		
76513	TC	Echo exam of eye, water bath		\$114		
76514	26	Echo exam of eye thickness		\$20		
76514	TC	Echo exam of eye thickness		\$11		
76514		Echo exam of eye thickness		\$31		
76516		Echo exam of eye		\$149		
76516	26	Echo exam of eye		\$59		
76516	TC	Echo exam of eye		\$90		
76519		Echo exam of eye		\$149		
76519	26	Echo exam of eye		\$59		
76519	TC	Echo exam of eye		\$90		
76529		Echo exam of eye		\$160		
76529	26	Echo exam of eye		\$62		
76529	TC	Echo exam of eye		\$98		
76536		Echo exam of head and neck		\$163		
76536	26	Echo exam of head and neck		\$61		
76536	TC	Echo exam of head and neck		\$102		
76604		Echo exam of chest		\$154		
76604	26	Echo exam of chest		\$61		
76604	TC	Echo exam of chest		\$94		
76645		Echo exam of breast		\$135		
76645	26	Echo exam of breast		\$59		
76645	TC	Echo exam of breast		\$76		
76700		Echo exam of abdomen		\$229		
76700	26	Echo exam of abdomen		\$87		
76700	TC	Echo exam of abdomen		\$142		
76705		Echo exam of abdomen		\$166		
76705	26	Echo exam of abdomen		\$64		
76705	TC	Echo exam of abdomen		\$102		
76770		Echo exam abdomen back wall		\$222		
76770	26	Echo exam abdomen back wall		\$80		
76770	TC	Echo exam abdomen back wall		\$142		
76775		Echo exam abdomen back wall		\$165		
76775	26	Echo exam abdomen back wall		\$63		
76775	TC	Echo exam abdomen back wall		\$102		
76776	26	Us exam k transpl w/doppler		\$76		
76776	TC	Us exam k transpl w/doppler		\$245		
76776		Us exam k transpl w/doppler		\$321		



Title 40, Part I

CPT Code	Mod	Description	Global Days	Maximum Allowance	Non-Facility Maximum	Facility Maximum
76778	TC			\$142		
76800		Echo exam spinal canal		\$223		
76800	26	Echo exam spinal canal		\$122		
76800	TC	Echo exam spinal canal		\$102		
76801	26	Ob us < 14 wks single fetus		\$99		
76801	TC	Ob us < 14 wks single fetus		\$167		
76801		Ob us < 14 wks single fetus		\$266		
76802	26	Ob us < 14 wks addl fetus		\$84		
76802	TC	Ob us < 14 wks addl fetus		\$56		
76802		Ob us < 14 wks addl fetus		\$140		
76805		Echo exam of pregnant uterus		\$257		
76805	26	Echo exam of pregnant uterus		\$107		
76805	TC	Echo exam of pregnant uterus		\$151		
76810		Echo exam of pregnant uterus		\$511		
76810	26	Echo exam of pregnant uterus		\$211		
76810	TC	Echo exam of pregnant uterus		\$301		
76811	26	Ob us detailed snl fetus		\$196		
76811	TC	Ob us detailed snl fetus		\$194		
76811		Ob us detailed snl fetus		\$390		
76812	26	Ob us detailed addl fetus		\$184		
76812	TC	Ob us detailed addl fetus		\$262		
76812		Ob us detailed addl fetus		\$446		
76813	26	Ob us nuchal meas 1 gest		\$123		
76813	TC	Ob us nuchal meas 1 gest		\$138		
76813		Ob us nuchal meas 1 gest		\$261		
76814	26	Ob us nuchal meas add-on		\$103		
76814	TC	Ob us nuchal meas add-on		\$67		
76814		Ob us nuchal meas add-on		\$170		
76815		Echo exam of pregnant uterus		\$175		
76815	26	Echo exam of pregnant uterus		\$69		
76815	TC	Echo exam of pregnant uterus		\$106		
76816		Echo exam followup or repeat		\$142		
76816	26	Echo exam followup or repeat		\$62		
76816	TC	Echo exam followup or repeat		\$80		
76817	26	Transvaginal us obstetric		\$77		
76817	TC	Transvaginal us obstetric		\$138		
76817		Transvaginal us obstetric		\$215		
76818		Fetal biophysical profile		\$199		
76818	26	Fetal biophysical profile		\$83		
76818	TC	Fetal biophysical profile		\$117		
76819	26	Fetal biophys profil w/o nst		\$79		
76819	TC	Fetal biophys profil w/o nst		\$108		
76819		Fetal biophys profil w/o nst		\$187		
76820	26	Umbilical artery echo		\$52		
76820	TC	Umbilical artery echo		\$33		
76820		Umbilical artery echo		\$85		
76821	26	Middle cerebral artery echo		\$74		
76821	TC	Middle cerebral artery echo		\$129		
76821		Middle cerebral artery echo		\$203		
76825		Echo exam of fetal heart		\$239		
76825	26	Echo exam of fetal heart		\$98		
76825	TC	Echo exam of fetal heart		\$142		
76826		Echo exam of fetal heart		\$162		
76826	26	Echo exam of fetal heart		\$111		
76826	TC	Echo exam of fetal heart		\$52		
76827		Echo exam of fetal heart		\$220		
76827	26	Echo exam of fetal heart		\$94		
76827	TC	Echo exam of fetal heart		\$126		
76828		Echo exam of fetal heart		\$143		
76828	26	Echo exam of fetal heart		\$61		
76828	TC	Echo exam of fetal heart		\$82		
76830		Echo exam, transvaginal		\$185		
76830	26	Echo exam, transvaginal		\$75		
76830	TC	Echo exam, transvaginal		\$110		
76831		Echo exam, uterus.....		\$189		
76831	26	Echo exam, uterus.....		\$75		

LABOR AND EMPLOYMENT

CPT Code	Mod	Description	Global Days	Maximum Allowance	Non-Facility Maximum	Facility Maximum
76831	TC	Echo exam, uterus....		\$114		
76856		Echo exam of pelvis		\$185		
76856	26	Echo exam of pelvis		\$75		
76856	TC	Echo exam of pelvis		\$110		
76857		Echo exam of pelvis		\$117		
76857	26	Echo exam of pelvis		\$41		
76857	TC	Echo exam of pelvis		\$76		
76870		Echo exam of scrotum		\$179		
76870	26	Echo exam of scrotum		\$69		
76870	TC	Echo exam of scrotum		\$110		
76872		Echo exam, transrectal		\$187		
76872	26	Echo exam, transrectal		\$73		
76872	TC	Echo exam, transrectal		\$114		
76873		Echograp trans r, pros study		358		
76873	26	Echograp trans r, pros study		\$157		
76873	TC	Echograp trans r, pros study		\$200		
76881	26	Us xtr non-vasc complete		\$63		
76881	TC	Us xtr non-vasc complete		\$190		
76881		Us xtr non-vasc complete		\$254		
76882	26	Us xtr non-vasc lmtd		\$50		
76882	TC	Us xtr non-vasc lmtd		\$22		
76882		Us xtr non-vasc lmtd		\$72		
76885		Echo exam, infant hips		\$190		
76885	26	Echo exam, infant hips		\$76		
76885	TC	Echo exam, infant hips		\$114		
76886		Echo exam, infant hips		\$170		
76886	26	Echo exam, infant hips		\$64		
76886	TC	Echo exam, infant hips		\$106		
76930		Echo guide for heart sac tap		\$183		
76930	26	Echo guide for heart sac tap		\$73		
76930	TC	Echo guide for heart sac tap		\$110		
76932		Echo guide for heart biopsy		\$183		
76932	26	Echo guide for heart biopsy		\$73		
76932	TC	Echo guide for heart biopsy		\$110		
76936		Echo guide for artery repair		\$600		
76936	26	Echo guide for artery repair		\$153		
76936	TC	Echo guide for artery repair		\$447		
76937	26	Us guide vascular access		\$30		
76937	TC	Us guide vascular access		\$42		
76937		Us guide vascular access		\$72		
76940		Us guide tissue ablation		\$213		
76941		Echo guide for transfusion		\$252		
76941	26	Echo guide for transfusion		\$144		
76941	TC	Echo guide for transfusion		\$109		
76942		Echo guide for biopsy		\$183		
76942	26	Echo guide for biopsy		\$73		
76942	TC	Echo guide for biopsy		\$110		
76945		Echo guide, villus sampling		\$205		
76945	26	Echo guide, villus sampling		\$97		
76945	TC	Echo guide, villus sampling		\$109		
76946		Echo guide for amniocentesis		\$151		
76946	26	Echo guide for amniocentesis		\$41		
76946	TC	Echo guide for amniocentesis		\$110		
76948		Echo guide, ova aspiration		\$151		
76948	26	Echo guide, ova aspiration		\$41		
76948	TC	Echo guide, ova aspiration		\$110		
76950		Echo guidance radiotherapy		\$157		
76950	26	Echo guidance radiotherapy		\$63		
76950	TC	Echo guidance radiotherapy		\$94		
76965		Echo guidance radiotherapy		\$611		
76965	26	Echo guidance radiotherapy		\$195		
76965	TC	Echo guidance radiotherapy		\$416		
76970		Ultrasound exam follow-up		\$119		
76970	26	Ultrasound exam follow-up		\$43		
76970	TC	Ultrasound exam follow-up		\$76		
76975		Gi endoscopic ultrasound		\$195		

Title 40, Part I

CPT Code	Mod	Description	Global Days	Maximum Allowance	Non-Facility Maximum	Facility Maximum
76975	26	Gi endoscopic ultrasound		\$85		
76975	TC	Gi endoscopic ultrasound		\$110		
76977		Us bone density measure		\$85		
76977	26	Us bone density measure		\$22		
76977	TC	Us bone density measure		\$62		
76998		Us guide intraop		\$134		
76999		Echo examination procedure		BR		
76999	26	Echo examination procedure		BR		
76999	TC	Echo examination procedure		BR		
77001	26	Fluoroguide for vein device		\$38		
77001	TC	Fluoroguide for vein device		\$210		
77001		Fluoroguide for vein device		\$248		
77002	26	Needle localization by xray		\$57		
77002	TC	Needle localization by xray		\$107		
77002		Needle localization by xray		\$163		
77003	26	Fluoroguide for spine inject		\$64		
77003	TC	Fluoroguide for spine inject		\$73		
77003		Fluoroguide for spine inject		\$136		
77011	26	Ct scan for localization		\$125		
77011	TC	Ct scan for localization		\$357		
77011		Ct scan for localization		\$482		
77012	26	Ct scan for needle biopsy		\$113		
77012	TC	Ct scan for needle biopsy		\$151		
77012		Ct scan for needle biopsy		\$265		
77013		Ct guide for tissue ablation		\$405		
77014	26	Ct scan for therapy guide		\$86		
77014	TC	Ct scan for therapy guide		\$171		
77014		Ct scan for therapy guide		\$257		
77021	26	Mr guidance for needle place		\$151		
77021	TC	Mr guidance for needle place		\$659		
77021		Mr guidance for needle place		\$810		
77022		Mri for tissue ablation		\$427		
77031	26	Stereotact guide for brst bx		\$161		
77031	TC	Stereotact guide for brst bx		\$105		
77031		Stereotact guide for brst bx		\$267		
77032	26	Guidance for needle breast		\$56		
77032	TC	Guidance for needle breast		\$50		
77032		Guidance for needle breast		\$106		
77051	26	Computer dx mammogram add-on		\$6		
77051	TC	Computer dx mammogram add-on		\$15		
77051		Computer dx mammogram add-on		\$21		
77052	26	Comp screen mammogram add-on		\$6		
77052	TC	Comp screen mammogram add-on		\$14		
77052		Comp screen mammogram add-on		\$20		
77053	26	X-ray of mammary duct		\$35		
77053	TC	X-ray of mammary duct		\$85		
77053		X-ray of mammary duct		\$121		
77054	26	X-ray of mammary ducts		\$45		
77054	TC	X-ray of mammary ducts		\$119		
77054		X-ray of mammary ducts		\$164		
77055	26	Mammogram one breast		\$70		
77055	TC	Mammogram one breast		\$109		
77055		Mammogram one breast		\$179		
77056	26	Mammogram both breasts		\$87		
77056	TC	Mammogram both breasts		\$142		
77056		Mammogram both breasts		\$229		
77057	26	Mammogram screening		\$70		
77057	TC	Mammogram screening		\$93		
77057		Mammogram screening		\$164		
77058	26	Mri one breast		\$162		
77058	TC	Mri one breast		\$1,135		
77058		Mri one breast		\$1,297		
77059	26	Mri both breasts		\$162		
77059	TC	Mri both breasts		\$1,131		
77059		Mri both breasts		\$1,293		
77071		X-ray stress view		\$109		

LABOR AND EMPLOYMENT

CPT Code	Mod	Description	Global Days	Maximum Allowance	Non-Facility Maximum	Facility Maximum
77072	26	X-rays for bone age		\$19		
77072	TC	X-rays for bone age		\$29		
77072		X-rays for bone age		\$48		
77073	26	X-rays bone length studies		\$30		
77073	TC	X-rays bone length studies		\$51		
77073		X-rays bone length studies		\$81		
77074	26	X-rays bone survey limited		\$45		
77074	TC	X-rays bone survey limited		\$98		
77074		X-rays bone survey limited		\$144		
77075	26	X-rays bone survey complete		\$54		
77075	TC	X-rays bone survey complete		\$162		
77075		X-rays bone survey complete		\$216		
77076	26	X-rays bone survey infant		\$72		
77076	TC	X-rays bone survey infant		\$160		
77076		X-rays bone survey infant		\$232		
77077	26	Joint survey single view		\$35		
77077	TC	Joint survey single view		\$51		
77077		Joint survey single view		\$85		
77078	26	Ct bone density axial		\$25		
77078	TC	Ct bone density axial		\$256		
77078		Ct bone density axial		\$281		
77080	26	Dxa bone density axial		\$21		
77080	TC	Dxa bone density axial		\$84		
77080		Dxa bone density axial		\$105		
77081	26	Dxa bone density/peripheral		\$23		
77081	TC	Dxa bone density/peripheral		\$35		
77081		Dxa bone density/peripheral		\$58		
77082	26	Dxa bone density vert fx		\$18		
77082	TC	Dxa bone density vert fx		\$40		
77082		Dxa bone density vert fx		\$58		
77084	26	Magnetic image bone marrow		\$160		
77084	TC	Magnetic image bone marrow		\$756		
77084		Magnetic image bone marrow		\$916		
77261		Radiation therapy planning		\$150		
77262		Radiation therapy planning		\$226		
77263		Radiation therapy planning		\$336		
77280		Set radiation therapy field		\$325		
77280	26	Set radiation therapy field		\$76		
77280	TC	Set radiation therapy field		\$250		
77285		Set radiation therapy field		\$512		
77285	26	Set radiation therapy field		\$112		
77285	TC	Set radiation therapy field		\$400		
77290		Set radiation therapy field		\$635		
77290	26	Set radiation therapy field		\$168		
77290	TC	Set radiation therapy field		\$467		
77295		Set radiation therapy field		\$2,558		
77295	26	Set radiation therapy field		\$472		
77295	TC	Set radiation therapy field		\$2,086		
77299		Radiation therapy planning		BR		
77299	26	Radiation therapy planning		BR		
77299	TC	Radiation therapy planning		BR		
77300		Radiation therapy dose plan		\$163		
77300	26	Radiation therapy dose plan		\$67		
77300	TC	Radiation therapy dose plan		\$96		
77301	26	Radiotherapy dose plan imrt		\$815		
77301	TC	Radiotherapy dose plan imrt		\$2,998		
77301		Radiotherapy dose plan imrt		\$3,813		
77305		Radiation therapy dose plan		\$210		
77305	26	Radiation therapy dose plan		\$76		
77305	TC	Radiation therapy dose plan		\$134		
77310		Radiation therapy dose plan		\$280		
77310	26	Radiation therapy dose plan		\$112		
77310	TC	Radiation therapy dose plan		\$168		
77315		Radiation therapy dose plan		\$360		
77315	26	Radiation therapy dose plan		\$168		
77315	TC	Radiation therapy dose plan		\$192		

Title 40, Part I

CPT Code	Mod	Description	Global Days	Maximum Allowance	Non-Facility Maximum	Facility Maximum
77321		Radiation therapy port plan		\$391		
77321	26	Radiation therapy port plan		\$102		
77321	TC	Radiation therapy port plan		\$290		
77326		Radiation therapy dose plan		\$270		
77326	26	Radiation therapy dose plan		\$100		
77326	TC	Radiation therapy dose plan		\$171		
77327		Radiation therapy dose plan		\$399		
77327	26	Radiation therapy dose plan		\$150		
77327	TC	Radiation therapy dose plan		\$250		
77328		Radiation therapy dose plan		\$579		
77328	26	Radiation therapy dose plan		\$224		
77328	TC	Radiation therapy dose plan		\$356		
77331		Special radiation dosimetry		\$130		
77331	26	Special radiation dosimetry		\$94		
77331	TC	Special radiation dosimetry		\$37		
77332		Radiation treatment aid(s)		\$155		
77332	26	Radiation treatment aid(s)		\$59		
77332	TC	Radiation treatment aid(s)		\$96		
77333		Radiation treatment aid(s)		\$227		
77333	26	Radiation treatment aid(s)		\$91		
77333	TC	Radiation treatment aid(s)		\$137		
77334		Radiation treatment aid(s)		\$364		
77334	26	Radiation treatment aid(s)		\$132		
77334	TC	Radiation treatment aid(s)		\$233		
77336		Radiation physics consult.		\$223		
77338	26	Design mlc device for imrt		\$438		
77338	TC	Design mlc device for imrt		\$576		
77338		Design mlc device for imrt		\$1,014		
77370		Radiation physics consult		\$251		
77372		Srs linear based		\$1,651		
77373		Sbrt delivery		\$3,176		
77401		Radiation treatment delivery		\$128		
77402		Radiation treatment delivery		\$128		
77403		Radiation treatment delivery		\$128		
77404		Radiation treatment delivery		\$128		
77406		Radiation treatment delivery		\$128		
77407		Radiation treatment delivery		\$150		
77408		Radiation treatment delivery		\$150		
77409		Radiation treatment delivery		\$150		
77411		Radiation treatment delivery		\$150		
77412		Radiation treatment delivery		\$168		
77413		Radiation treatment delivery		\$168		
77414		Radiation treatment delivery		\$168		
77416		Radiation treatment delivery		\$168		
77417		Radiology port film(s)		\$43		
77418		Radiation tx delivery imrt		\$896		
77421	26	Stereoscopic x-ray guidance		\$39		
77421	TC	Stereoscopic x-ray guidance		\$114		
77421		Stereoscopic x-ray guidance		\$153		
77422		Neutron beam tx simple		\$540		
77423		Neutron beam tx complex		\$541		
77427		Radiation tx management, x5		\$366		
77427		Radiation tx management x5		\$366		
77431		Radiation therapy management		\$194		
77432		Stereotactic radiation trmt		\$939		
77435		Sbrt management		\$1,246		
77469		Io radiation tx management		\$618		
77470		Special radiation treatment		\$1,022		
77470	26	Special radiation treatment		\$224		
77470	TC	Special radiation treatment		\$799		
77499		Radiation therapy management		BR		
77499	26	Radiation therapy management		BR		
77499	TC	Radiation therapy management		BR		
77520		Proton beam delivery..		BR		
77523		Proton beam delivery..		BR		
77600		Hyperthermia treatment		\$386		

LABOR AND EMPLOYMENT

CPT Code	Mod	Description	Global Days	Maximum Allowance	Non-Facility Maximum	Facility Maximum
77600	26	Hyperthermia treatment		\$168		
77600	TC	Hyperthermia treatment		\$218		
77605		Hyperthermia treatment		\$515		
77605	26	Hyperthermia treatment		\$224		
77605	TC	Hyperthermia treatment		\$292		
77610		Hyperthermia treatment		\$386		
77610	26	Hyperthermia treatment		\$168		
77610	TC	Hyperthermia treatment		\$218		
77615		Hyperthermia treatment		\$515		
77615	26	Hyperthermia treatment		\$224		
77615	TC	Hyperthermia treatment		\$292		
77620		Hyperthermia treatment		\$386		
77620	26	Hyperthermia treatment		\$168		
77620	TC	Hyperthermia treatment		\$218		
77750		Infuse radioactive materials	90	\$586		
77750	26	Infuse radioactive materials	90	\$491		
77750	TC	Infuse radioactive materials	90	\$96		
77761		Radioelement application	90	\$562		
77761	26	Radioelement application	90	\$381		
77761	TC	Radioelement application	90	\$181		
77762		Radioelement application	90	\$832		
77762	26	Radioelement application	90	\$573		
77762	TC	Radioelement application	90	\$259		
77763		Radioelement application	90	\$1,179		
77763	26	Radioelement application	90	\$857		
77763	TC	Radioelement application	90	\$322		
77776		Radioelement application		\$656		
77776	26	Radioelement application		\$500		
77776	TC	Radioelement application		\$157		
77777		Radioelement application	90	\$1,052		
77777	26	Radioelement application	90	\$748		
77777	TC	Radioelement application	90	\$304		
77778		Radioelement application	90	\$1,488		
77778	26	Radioelement application	90	\$1,120		
77778	TC	Radioelement application	90	\$368		
77785	26	Hdr brachytx 1 channel		\$145		
77785	TC	Hdr brachytx 1 channel		\$357		
77785		Hdr brachytx 1 channel		\$502		
77786	26	Hdr brachytx 2-12 channel		\$332		
77786	TC	Hdr brachytx 2-12 channel		\$792		
77786		Hdr brachytx 2-12 channel		\$1,123		
77787	26	Hdr brachytx over 12 chan		\$501		
77787	TC	Hdr brachytx over 12 chan		\$1,429		
77787		Hdr brachytx over 12 chan		\$1,930		
77789		Radioelement application	90	\$145		
77789	26	Radioelement application	90	\$112		
77789	TC	Radioelement application	90	\$33		
77790		Radioelement handling		\$149		
77790	26	Radioelement handling		\$112		
77790	TC	Radioelement handling		\$37		
77799		Radium/radioisotope therapy		BR		
77799	26	Radium/radioisotope therapy		BR		
77799	TC	Radium/radioisotope therapy		BR		
78000		Thyroid, single uptake		\$90		
78000	26	Thyroid, single uptake		\$21		
78000	TC	Thyroid, single uptake		\$70		
78001		Thyroid, multiple uptakes		\$122		
78001	26	Thyroid, multiple uptakes		\$28		
78001	TC	Thyroid, multiple uptakes		\$94		
78003		Thyroid suppress/stimul		\$105		
78003	26	Thyroid suppress/stimul		\$35		
78003	TC	Thyroid suppress/stimul		\$70		
78006		Thyroid,imaging with uptake		\$224		
78006	26	Thyroid,imaging with uptake		\$53		
78006	TC	Thyroid,imaging with uptake		\$172		
78007		Thyroid,imaging with uptake		\$239		

Title 40, Part I

CPT Code	Mod	Description	Global Days	Maximum Allowance	Non-Facility Maximum	Facility Maximum
78007	26	Thyroid,imaging with uptake		\$54		
78007	TC	Thyroid,imaging with uptake		\$185		
78010		Thyroid imaging		\$172		
78010	26	Thyroid imaging		\$42		
78010	TC	Thyroid imaging		\$131		
78011		Thyroid imaging with flow		\$222		
78011	26	Thyroid imaging with flow		\$49		
78011	TC	Thyroid imaging with flow		\$173		
78015		Thyroid met imaging		\$258		
78015	26	Thyroid met imaging		\$73		
78015	TC	Thyroid met imaging		\$185		
78016		Thyroid met imaging/studies		\$339		
78016	26	Thyroid met imaging/studies		\$89		
78016	TC	Thyroid met imaging/studies		\$250		
78018		Thyroid, met imaging, body		\$491		
78018	26	Thyroid, met imaging, body		\$102		
78018	TC	Thyroid, met imaging, body		\$390		
78020		Thyroid met uptake....		\$60		
78020	26	Thyroid met uptake....		\$45		
78020	TC	Thyroid met uptake....		\$15		
78070		Parathyroid nuclear imaging		\$186		
78070	26	Parathyroid nuclear imaging		\$56		
78070	TC	Parathyroid nuclear imaging		\$131		
78075		Adrenal nuclear imaging		\$469		
78075	26	Adrenal nuclear imaging		\$80		
78075	TC	Adrenal nuclear imaging		\$390		
78099		Endocrine nuclear procedure		BR		
78099	26	Endocrine nuclear procedure		BR		
78099	TC	Endocrine nuclear procedure		BR		
78102		Bone marrow imaging, ltd		\$206		
78102	26	Bone marrow imaging, ltd		\$60		
78102	TC	Bone marrow imaging, ltd		\$147		
78103		Bone marrow imaging, mult		\$308		
78103	26	Bone marrow imaging, mult		\$81		
78103	TC	Bone marrow imaging, mult		\$227		
78104		Bone marrow imaging, body		\$378		
78104	26	Bone marrow imaging, body		\$87		
78104	TC	Bone marrow imaging, body		\$292		
78110		Plasma volume, single		\$91		
78110	26	Plasma volume, single		\$20		
78110	TC	Plasma volume, single		\$71		
78111		Plasma volume, multiple		\$209		
78111	26	Plasma volume, multiple		\$24		
78111	TC	Plasma volume, multiple		\$185		
78120		Red cell mass, single		\$150		
78120	26	Red cell mass, single		\$26		
78120	TC	Red cell mass, single		\$125		
78121		Red cell mass, multiple		\$243		
78121	26	Red cell mass, multiple		\$35		
78121	TC	Red cell mass, multiple		\$208		
78122		Blood volume.....		\$391		
78122	26	Blood volume.....		\$47		
78122	TC	Blood volume.....		\$344		
78130		Red cell survival study		\$271		
78130	26	Red cell survival study		\$66		
78130	TC	Red cell survival study		\$205		
78135		Red cell survival kinetics		\$418		
78135	26	Red cell survival kinetics		\$69		
78135	TC	Red cell survival kinetics		\$350		
78140		Red cell sequestration		\$348		
78140	26	Red cell sequestration		\$66		
78140	TC	Red cell sequestration		\$283		
78185		Spleen imaging		\$213		
78185	26	Spleen imaging		\$43		
78185	TC	Spleen imaging		\$170		
78190		Platelet survival, kinetics		\$527		

LABOR AND EMPLOYMENT

CPT Code	Mod	Description	Global Days	Maximum Allowance	Non-Facility Maximum	Facility Maximum
78190	26	Platelet survival, kinetics		\$117		
78190	TC	Platelet survival, kinetics		\$411		
78191		Platelet survival		\$592		
78191	26	Platelet survival		\$66		
78191	TC	Platelet survival		\$526		
78195		Lymph system imaging		\$368		
78195	26	Lymph system imaging		\$76		
78195	TC	Lymph system imaging		\$292		
78199		Blood/lymph nuclear exam		BR		
78199	26	Blood/lymph nuclear exam		BR		
78199	TC	Blood/lymph nuclear exam		BR		
78201		Liver imaging		\$216		
78201	26	Liver imaging		\$47		
78201	TC	Liver imaging		\$170		
78202		Liver imaging with flow		\$262		
78202	26	Liver imaging with flow		\$56		
78202	TC	Liver imaging with flow		\$207		
78205		Liver imaging (3D)....		\$516		
78205	26	Liver imaging (3D)....		\$75		
78205	TC	Liver imaging (3D)....		\$441		
78206		Liver image (3d) w/ flow		\$516		
78206	26	Liver image (3d) w/ flow		\$89		
78206	TC	Liver image (3d) w/ flow		\$428		
78215		Liver and spleen imaging		\$263		
78215	26	Liver and spleen imaging		\$53		
78215	TC	Liver and spleen imaging		\$210		
78216		Liver & spleen image, flow		\$312		
78216	26	Liver & spleen image, flow		\$62		
78216	TC	Liver & spleen image, flow		\$250		
78220		Liver function study		\$320		
78226	26	Hepatobiliary system imaging		\$73		
78226	TC	Hepatobiliary system imaging		\$601		
78226		Hepatobiliary system imaging		\$674		
78227	26	Hepatobil syst image w/drug		\$88		
78227	TC	Hepatobil syst image w/drug		\$835		
78227		Hepatobil syst image w/drug		\$923		
78230		Salivary gland imaging		\$206		
78230	26	Salivary gland imaging		\$49		
78230	TC	Salivary gland imaging		\$157		
78231		Serial salivary imaging		\$284		
78231	26	Serial salivary imaging		\$57		
78231	TC	Serial salivary imaging		\$227		
78232		Salivary gland function exam		\$305		
78232	26	Salivary gland function exam		\$52		
78232	TC	Salivary gland function exam		\$254		
78258		Esophageal motility study		\$287		
78258	26	Esophageal motility study		\$80		
78258	TC	Esophageal motility study		\$207		
78261		Gastric mucosa imaging		\$369		
78261	26	Gastric mucosa imaging		\$75		
78261	TC	Gastric mucosa imaging		\$294		
78262		Gastroesophageal reflux exam		\$378		
78262	26	Gastroesophageal reflux exam		\$74		
78262	TC	Gastroesophageal reflux exam		\$305		
78264		Gastric emptying study		\$380		
78264	26	Gastric emptying study		\$84		
78264	TC	Gastric emptying study		\$296		
78267		Breath tst attain/anal c-14		BR		
78268		Breath test analysis, c-14		BR		
78270		Vit b-12 absorption exam		\$133		
78270	26	Vit b-12 absorption exam		\$22		
78270	TC	Vit b-12 absorption exam		\$112		
78271		Vit b-12 absorp exam, if		\$140		
78271	26	Vit b-12 absorp exam, if		\$22		
78271	TC	Vit b-12 absorp exam, if		\$119		
78272		Vit b-12 absorp, combined		\$196		



Title 40, Part I

CPT Code	Mod	Description	Global Days	Maximum Allowance	Non-Facility Maximum	Facility Maximum
78272	26	Vit b-12 absorp, combined		\$30		
78272	TC	Vit b-12 absorp, combined		\$167		
78278		Acute gi blood loss imaging		\$456		
78278	26	Acute gi blood loss imaging		\$107		
78278	TC	Acute gi blood loss imaging		\$350		
78282		Gi protein loss exam		BR		
78282	26	Gi protein loss exam		\$41		
78282	TC	Gi protein loss exam		BR		
78290		Meckel's divert exam		\$292		
78290	26	Meckel's divert exam		\$74		
78290	TC	Meckel's divert exam		\$218		
78291		Leveen/shunt patency exam		\$313		
78291	26	Leveen/shunt patency exam		\$94		
78291	TC	Leveen/shunt patency exam		\$220		
78299		Gi nuclear procedure		BR		
78299	26	Gi nuclear procedure		BR		
78299	TC	Gi nuclear procedure		BR		
78300		Bone imaging, limited area		\$247		
78300	26	Bone imaging, limited area		\$68		
78300	TC	Bone imaging, limited area		\$180		
78305		Bone imaging, multiple areas		\$353		
78305	26	Bone imaging, multiple areas		\$90		
78305	TC	Bone imaging, multiple areas		\$263		
78306		Bone imaging, whole body		\$399		
78306	26	Bone imaging, whole body		\$93		
78306	TC	Bone imaging, whole body		\$307		
78315		Bone imaging, 3 phase		\$452		
78315	26	Bone imaging, 3 phase		\$110		
78315	TC	Bone imaging, 3 phase		\$343		
78320		Bone imaging (3d)		\$535		
78320	26	Bone imaging (3d)		\$112		
78320	TC	Bone imaging (3d)		\$424		
78350		Bone mineral, single photon		\$80		
78350	26	Bone mineral, single photon		\$24		
78350	TC	Bone mineral, single photon		\$57		
78351		Bone mineral, dual photon		\$55		
78399		Musculoskeletal nuclear exam		BR		
78399	26	Musculoskeletal nuclear exam		BR		
78399	TC	Musculoskeletal nuclear exam		BR		
78414		Non-imaging heart function		BR		
78414	26	Non-imaging heart function		\$48		
78414	TC	Non-imaging heart function		BR		
78428		Cardiac shunt imaging		\$246		
78428	26	Cardiac shunt imaging		\$84		
78428	TC	Cardiac shunt imaging		\$162		
78445		Vascular flow imaging		\$191		
78445	26	Vascular flow imaging		\$52		
78445	TC	Vascular flow imaging		\$139		
78451	26	Ht muscle image spect sing		\$136		
78451	TC	Ht muscle image spect sing		\$606		
78451		Ht muscle image spect sing		\$742		
78452	26	Ht muscle image spect mult		\$160		
78452	TC	Ht muscle image spect mult		\$875		
78452		Ht muscle image spect mult		\$1,035		
78453	26	Ht muscle image planar sing		\$99		
78453	TC	Ht muscle image planar sing		\$541		
78453		Ht muscle image planar sing		\$639		
78454	26	Ht musc image planar mult		\$131		
78454	TC	Ht musc image planar mult		\$782		
78454		Ht musc image planar mult		\$913		
78456		Acute venous thrombus image		\$797		
78456	26	Acute venous thrombus image		\$100		
78456	TC	Acute venous thrombus		\$697		
78457		Venous thrombosis imaging		\$279		
78457	26	Venous thrombosis imaging		\$80		
78457	TC	Venous thrombosis imaging		\$199		

LABOR AND EMPLOYMENT

CPT Code	Mod	Description	Global Days	Maximum Allowance	Non-Facility Maximum	Facility Maximum
78458		Ven thrombosis images, bilat		\$384		
78458	26	Ven thrombosis images, bilat		\$96		
78458	TC	Ven thrombosis images, bilat		\$288		
78459		Heart muscle imaging (PET)		BR		
78459	26	Heart muscle imaging (PET)		\$225		
78459	TC	Heart muscle imaging (PET)		BR		
78466		Heart infarct image		\$264		
78466	26	Heart infarct image		\$75		
78466	TC	Heart infarct image		\$189		
78468		Heart infarct image, ef		\$348		
78468	26	Heart infarct image, ef		\$86		
78468	TC	Heart infarct image, ef		\$263		
78469		Heart infarct image (3D)		\$486		
78469	26	Heart infarct image (3D)		\$96		
78469	TC	Heart infarct image (3D)		\$390		
78472		Gated heart, planar, single		\$515		
78472	26	Gated heart, planar, single		\$103		
78472	TC	Gated heart, planar, single		\$413		
78473		Gated heart, multiple		\$770		
78473	26	Gated heart, multiple		\$154		
78473	TC	Gated heart, multiple		\$616		
78481		Heart first pass, single		\$493		
78481	26	Heart first pass, single		\$103		
78481	TC	Heart first pass, single		\$390		
78483		Heart first pass, multiple		\$743		
78483	26	Heart first pass, multiple		\$155		
78483	TC	Heart first pass, multiple		\$588		
78491		Heart image (pet), single		BR		
78491	26	Heart image (pet), single		\$196		
78491	TC	Heart image (pet), single		BR		
78492		Heart image (pet), multiple		BR		
78492	26	Heart image (pet), multiple		\$224		
78492	TC	Heart image (pet), multiple		BR		
78494		Heart image, spect....		\$525		
78494	26	Heart image, spect....		\$112		
78494	TC	Heart image, spect....		\$413		
78496		Heart first pass add- on		\$183		
78496	26	Heart first pass add- on		\$52		
78496	TC	Heart first pass add- on		\$131		
78499		Cardiovascular nuclear exam		BR		
78499	26	Cardiovascular nuclear exam		BR		
78499	TC	Cardiovascular nuclear exam		BR		
78579	26	Lung ventilation imaging		\$48		
78579	TC	Lung ventilation imaging		\$310		
78579		Lung ventilation imaging		\$359		
78580		Lung perfusion imaging		\$327		
78580	26	Lung perfusion imaging		\$80		
78580	TC	Lung perfusion imaging		\$247		
78582	26	Lung ventilat&perfus imaging		\$104		
78582	TC	Lung ventilat&perfus imaging		\$557		
78582		Lung ventilat&perfus imaging		\$662		
78597	26	Lung perfusion differential		\$72		
78597	TC	Lung perfusion differential		\$333		
78597		Lung perfusion differential		\$404		
78598	26	Lung perf&ventilat diferentl		\$82		
78598	TC	Lung perf&ventilat diferentl		\$539		
78598		Lung perf&ventilat diferentl		\$621		
78599		Respiratory nuclear exam		BR		
78599	26	Respiratory nuclear exam		BR		
78599	TC	Respiratory nuclear exam		BR		
78600		Brain imaging, ltd static		\$254		
78600	26	Brain imaging, ltd static		\$47		
78600	TC	Brain imaging, ltd static		\$207		
78605		Brain imaging, complete		\$302		
78605	26	Brain imaging, complete		\$59		
78605	TC	Brain imaging, complete		\$244		

Title 40, Part I

CPT Code	Mod	Description	Global Days	Maximum Allowance	Non-Facility Maximum	Facility Maximum
78606		Brain imaging comp & flow		\$346		
78606	26	Brain imaging comp & flow		\$69		
78606	TC	Brain imaging comp & flow		\$278		
78607		Brain imaging (3d)		\$601		
78607	26	Brain imaging (3d)		\$131		
78607	TC	Brain imaging (3d)		\$470		
78608		Brain imaging (pet)		\$145		
78609		Brain imaging (pet)		\$156		
78610		Brain flow imaging only		\$146		
78610	26	Brain flow imaging only		\$33		
78610	TC	Brain flow imaging only		\$114		
78630		Cerebrospinal fluid scan		\$435		
78630	26	Cerebrospinal fluid scan		\$74		
78630	TC	Cerebrospinal fluid scan		\$362		
78635		Csf ventriculography		\$249		
78635	26	Csf ventriculography		\$66		
78635	TC	Csf ventriculography		\$183		
78645		Csf shunt evaluation		\$308		
78645	26	Csf shunt evaluation		\$62		
78645	TC	Csf shunt evaluation		\$247		
78647		Cerebrospinal fluid scan		\$515		
78647	26	Cerebrospinal fluid scan		\$96		
78647	TC	Cerebrospinal fluid scan		\$419		
78650		Csf leakage imaging		\$399		
78650	26	Csf leakage imaging		\$66		
78650	TC	Csf leakage imaging		\$333		
78660		Nuclear exam of tear flow		\$214		
78660	26	Nuclear exam of tear flow		\$56		
78660	TC	Nuclear exam of tear flow		\$158		
78699		Nervous system nuclear exam		BR		
78699	26	Nervous system nuclear exam		BR		
78699	TC	Nervous system nuclear exam		BR		
78700		Kidney imaging, static		\$266		
78700	26	Kidney imaging, static		\$48		
78700	TC	Kidney imaging, static		\$218		
78701		Kidney imaging with flow		\$308		
78701	26	Kidney imaging with flow		\$53		
78701	TC	Kidney imaging with flow		\$255		
78707		Kidney flow/function image		\$433		
78707	26	Kidney flow/function image		\$99		
78707	TC	Kidney flow/function image		\$334		
78708		Kidney flow/function image		\$452		
78708	26	Kidney flow/function image		\$118		
78708	TC	Kidney flow/function image		\$334		
78709		Kidney flow/function image		\$467		
78709	26	Kidney flow/function image		\$133		
78709	TC	Kidney flow/function image		\$334		
78710		Kidney imaging (3D)...		\$511		
78710	26	Kidney imaging (3D)...		\$70		
78710	TC	Kidney imaging (3D)...		\$441		
78725		Kidney function study		\$172		
78725	26	Kidney function study		\$39		
78725	TC	Kidney function study		\$133		
78730		Urinary bladder retention		\$143		
78730	26	Urinary bladder retention		\$38		
78730	TC	Urinary bladder retention		\$105		
78740		Ureteral reflux study		\$217		
78740	26	Ureteral reflux study		\$59		
78740	TC	Ureteral reflux study		\$158		
78761		Testicular imaging & flow		\$306		
78761	26	Testicular imaging & flow		\$77		
78761	TC	Testicular imaging & flow		\$229		
78799		Genitourinary nuclear exam		BR		
78799	26	Genitourinary nuclear exam		BR		
78799	TC	Genitourinary nuclear exam		BR		
78800		Tumor imaging, limited area		\$323		

LABOR AND EMPLOYMENT

CPT Code	Mod	Description	Global Days	Maximum Allowance	Non-Facility Maximum	Facility Maximum
78800	26	Tumor imaging, limited area		\$69		
78800	TC	Tumor imaging, limited area		\$254		
78801		Tumor imaging, mult areas		\$388		
78801	26	Tumor imaging, mult areas		\$85		
78801	TC	Tumor imaging, mult areas		\$304		
78802		Tumor imaging, whole body		\$490		
78802	26	Tumor imaging, whole body		\$93		
78802	TC	Tumor imaging, whole body		\$397		
78803		Tumor imaging (3D)....		\$602		
78803	26	Tumor imaging (3D)....		\$113		
78803	TC	Tumor imaging (3D)....		\$490		
78804	26	Tumor imaging whole body		\$103		
78804	TC	Tumor imaging whole body		\$1,085		
78804		Tumor imaging whole body		\$1,188		
78805		Abscess imaging, ltd area		\$330		
78805	26	Abscess imaging, ltd area		\$76		
78805	TC	Abscess imaging, ltd area		\$254		
78806		Abscess imaging, whole body		\$544		
78806	26	Abscess imaging, whole body		\$83		
78806	TC	Abscess imaging, whole body		\$462		
78807		Nuclear localization/abscess		\$586		
78807	26	Nuclear localization/abscess		\$117		
78807	TC	Nuclear localization/abscess		\$470		
78808		Iv inj ra drug dx study		\$84		
78811		Pet image ltd area		\$158		
78812		Pet image skull-thigh		\$192		
78813		Pet image full body		\$201		
78814		Pet image w/ct lmtd		\$221		
78815		Pet image w/ct skull-thigh		\$243		
78816		Pet image w/ct full body		\$245		
78990		Provide diag radionuclide(s)		BR		
78999		Nuclear diagnostic exam		BR		
78999	26	Nuclear diagnostic exam		BR		
78999	TC	Nuclear diagnostic exam		BR		
79005	26	Nuclear rx oral admin		\$176		
79005	TC	Nuclear rx oral admin		\$95		
79005		Nuclear rx oral admin		\$271		
79101	26	Nuclear rx iv admin		\$204		
79101	TC	Nuclear rx iv admin		\$102		
79101		Nuclear rx iv admin		\$306		
79200		Intracavitary nuc treatment		\$403		
79200	26	Intracavitary nuc treatment		\$214		
79200	TC	Intracavitary nuc treatment		\$189		
79300		Interstitial nuclear therapy		BR		
79300	26	Interstitial nuclear therapy		\$172		
79300	TC	Interstitial nuclear therapy		BR		
79403	26	Hematopoietic nuclear tx		\$218		
79403	TC	Hematopoietic nuclear tx		\$156		
79403		Hematopoietic nuclear tx		\$374		
79440		Nuclear joint therapy		\$403		
79440	26	Nuclear joint therapy		\$214		
79440	TC	Nuclear joint therapy		\$189		
79445		Nuclear rx intra-arterial		\$236		
79900		Provide ther radiopharm(s)		BR		
80048		Basic metabolic panel		BR		
80050		General health panel..		BR		
80050	26	General health panel..		BR		
80050	TC	General health panel..		BR		
80051		Electrolyte panel.....		BR		
80053		Comprehen metabolic panel		BR		
80055		Obstetric panel.....		\$106		
80055	26	Obstetric panel.....		\$43		
80055	TC	Obstetric panel.....		\$63		
80061		Lipid panel		\$88		
80061	26	Lipid panel		\$43		
80061	TC	Lipid panel		\$45		

Title 40, Part I

CPT Code	Mod	Description	Global Days	Maximum Allowance	Non-Facility Maximum	Facility Maximum
80069		Renal function panel..		BR		
80074		Acute hepatitis panel		BR		
80076		Hepatic function panel		BR		
80100		Drug screen		\$71		
80100	26	Drug screen		\$20		
80100	TC	Drug screen		\$51		
80101		Drug screen		\$65		
80101	26	Drug screen		\$18		
80101	TC	Drug screen		\$47		
80102		Drug confirmation		\$106		
80102	26	Drug confirmation		\$33		
80102	TC	Drug confirmation		\$73		
80103		Drug analysis, tissue		BR		
80103	26	Drug analysis, tissue		BR		
80103	TC	Drug analysis, tissue		BR		
80150		Assay of amikacin		\$75		
80150	26	Assay of amikacin		\$24		
80150	TC	Assay of amikacin		\$51		
80152		Assay of amitriptyline		\$81		
80152	26	Assay of amitriptyline		\$26		
80152	TC	Assay of amitriptyline		\$55		
80154		Assay of benzodiazepin		\$92		
80154	26	Assay of benzodiazepin		\$29		
80154	TC	Assay of benzodiazepin		\$63		
80156		Assay carbamazepine		\$65		
80156	26	Assay carbamazepine		\$20		
80156	TC	Assay carbamazepine		\$45		
80158		Assay of cyclosporine		BR		
80158	26	Assay of cyclosporine		BR		
80158	TC	Assay of cyclosporine		BR		
80160		Assay of desipramine		BR		
80160	26	Assay of desipramine		BR		
80160	TC	Assay of desipramine		BR		
80162		Assay for digoxin		\$61		
80162	26	Assay for digoxin		\$18		
80162	TC	Assay for digoxin		\$43		
80164		Assay, dipropylacetic		BR		
80164	26	Assay, dipropylacetic		BR		
80164	TC	Assay, dipropylacetic		BR		
80166		Assay of doxepin		\$65		
80166	26	Assay of doxepin		\$18		
80166	TC	Assay of doxepin		\$47		
80168		Assay of ethosuximide		\$82		
80168	26	Assay of ethosuximide		\$33		
80168	TC	Assay of ethosuximide		\$49		
80170		Gentamicin		\$84		
80170	26	Gentamicin		\$29		
80170	TC	Gentamicin		\$55		
80172		Assay for gold		\$83		
80172	26	Assay for gold		\$24		
80172	TC	Assay for gold		\$59		
80174		Assay of imipramine		\$77		
80174	26	Assay of imipramine		\$22		
80174	TC	Assay of imipramine		\$55		
80176		Assay for lidocaine		\$65		
80176	26	Assay for lidocaine		\$20		
80176	TC	Assay for lidocaine		\$45		
80178		Assay for lithium		\$32		
80178	26	Assay for lithium		\$12		
80178	TC	Assay for lithium		\$20		
80182		Assay for nortriptylin		BR		
80182	26	Assay for nortriptylin		BR		
80182	TC	Assay for nortriptylin		BR		
80184		Assay for phenobarbita		BR		
80184	26	Assay for phenobarbita		BR		
80184	TC	Assay for phenobarbita		BR		

LABOR AND EMPLOYMENT

CPT Code	Mod	Description	Global Days	Maximum Allowance	Non-Facility Maximum	Facility Maximum
80185		Assay for phenytoin		\$67		
80185	26	Assay for phenytoin		\$18		
80185	TC	Assay for phenytoin		\$49		
80186		Assay for phenytoin, f		BR		
80186	26	Assay for phenytoin, f		BR		
80186	TC	Assay for phenytoin, f		BR		
80188		Assay for primidone		\$65		
80188	26	Assay for primidone		\$20		
80188	TC	Assay for primidone		\$45		
80190		Assay for procainamide		\$77		
80190	26	Assay for procainamide		\$24		
80190	TC	Assay for procainamide		\$53		
80192		Assay for procainamide		BR		
80192	26	Assay for procainamide		BR		
80192	TC	Assay for procainamide		BR		
80194		Assay for quinidine		\$61		
80194	26	Assay for quinidine		\$18		
80194	TC	Assay for quinidine		\$43		
80196		Assay for salicylate		\$34		
80196	26	Assay for salicylate		\$10		
80196	TC	Assay for salicylate		\$24		
80197		Assay of tacrolimus...		BR		
80198		Assay for theophylline		\$51		
80198	26	Assay for theophylline		\$12		
80198	TC	Assay for theophylline		\$39		
80200		Assay for tobramycin		\$79		
80200	26	Assay for tobramycin		\$26		
80200	TC	Assay for tobramycin		\$53		
80201		Assay of topiramate...		BR		
80202		Assay for vancomycin		BR		
80202	26	Assay for vancomycin		BR		
80202	TC	Assay for vancomycin		BR		
80299		Quantitative assay, dr		BR		
80299	26	Quantitative assay, dr		BR		
80299	TC	Quantitative assay, dr		BR		
80400		Acth stimulation panel		\$141		
80400	26	Acth stimulation panel		\$41		
80400	TC	Acth stimulation panel		\$100		
80402		Acth stimulation panel		\$254		
80402	26	Acth stimulation panel		\$79		
80402	TC	Acth stimulation panel		\$175		
80406		Acth stimulation panel		\$254		
80406	26	Acth stimulation panel		\$79		
80406	TC	Acth stimulation panel		\$175		
80408		Aldosterone suppressio		\$312		
80408	26	Aldosterone suppressio		\$102		
80408	TC	Aldosterone suppressio		\$210		
80410		Calcitonin stimul panel.		\$289		
80410	26	Calcitonin stimul panel.		\$92		
80410	TC	Calcitonin stimul panel.		\$197		
80412		CRH stimulation panel		\$570		
80412	26	CRH stimulation panel		\$163		
80412	TC	CRH stimulation panel		\$407		
80414		Testosterone response		\$306		
80414	26	Testosterone response		\$98		
80414	TC	Testosterone response		\$208		
80415		Estradiol response pan		\$252		
80415	26	Estradiol response pan		\$61		
80415	TC	Estradiol response pan		\$191		
80416		Renin stimulation panel		BR		
80417		Renin stimulation panel		BR		
80418		Pituitary evaluation p		\$1,303		
80418	26	Pituitary evaluation p		\$350		
80418	TC	Pituitary evaluation p		\$953		
80420		Dexamethasone panel		\$197		
80420	26	Dexamethasone panel		\$61		

Title 40, Part I

CPT Code	Mod	Description	Global Days	Maximum Allowance	Non-Facility Maximum	Facility Maximum
80420	TC	Dexamethasone panel		\$136		
80422		Glucagon tolerance pan		\$116		
80422	26	Glucagon tolerance pan		\$35		
80422	TC	Glucagon tolerance pan		\$81		
80424		Glucagon tolerance pan		\$173		
80424	26	Glucagon tolerance pan		\$51		
80424	TC	Glucagon tolerance pan		\$122		
80426		Gonadotropin hormone p		\$269		
80426	26	Gonadotropin hormone p		\$53		
80426	TC	Gonadotropin hormone p		\$216		
80428		Growth hormone panel		\$171		
80428	26	Growth hormone panel		\$37		
80428	TC	Growth hormone panel		\$134		
80430		Growth hormone panel		\$183		
80430	26	Growth hormone panel		\$47		
80430	TC	Growth hormone panel		\$136		
80432		Insulin suppression pa		\$448		
80432	26	Insulin suppression pa		\$106		
80432	TC	Insulin suppression pa		\$342		
80434		Insulin tolerance pane		\$214		
80434	26	Insulin tolerance pane		\$61		
80434	TC	Insulin tolerance pane		\$153		
80435		Insulin tolerance pane		\$220		
80435	26	Insulin tolerance pane		\$61		
80435	TC	Insulin tolerance pane		\$159		
80436		Metyrapone panel		\$222		
80436	26	Metyrapone panel		\$65		
80436	TC	Metyrapone panel		\$157		
80438		TRH stimulation panel		\$89		
80438	26	TRH stimulation panel		\$22		
80438	TC	TRH stimulation panel		\$67		
80439		TRH stimulation panel		\$119		
80439	26	TRH stimulation panel		\$29		
80439	TC	TRH stimulation panel		\$90		
80440		TRH stimulation panel		\$149		
80440	26	TRH stimulation panel		\$49		
80440	TC	TRH stimulation panel		\$100		
80500		Lab pathology consulta		\$63		
80500	26	Lab pathology consulta		\$63		
80500	TC	Lab pathology consulta		\$0		
80502		Lab pathology consulta		\$132		
80502	26	Lab pathology consulta		\$132		
80502	TC	Lab pathology consulta		\$0		
81000		Urinalysis, nonauto w/scope		\$16		
81000	26	Urinalysis, nonauto w/scope		\$7		
81000	TC	Urinalysis, nonauto w/scope		\$9		
81001		Urinalysis, auto w/ scope		\$16		
81001	26	Urinalysis, auto w/ scope		\$7		
81001	TC	Urinalysis, auto w/ scope		\$9		
81002		Urinalysis nonauto w/o scope		\$14		
81002	26	Urinalysis nonauto w/o scope		\$7		
81002	TC	Urinalysis nonauto w/o scope		\$7		
81003		Urinalysis, auto, w/o scope		\$10		
81003	26	Urinalysis, auto, w/o scope		\$4		
81003	TC	Urinalysis, auto, w/o scope		\$6		
81005		Urinalysis		\$6		
81005	26	Urinalysis		\$2		
81005	TC	Urinalysis		\$4		
81007		Urine screen for bacte		\$6		
81007	26	Urine screen for bacte		\$2		
81007	TC	Urine screen for bacte		\$4		
81015		Microscopic exam of ur		\$10		
81015	26	Microscopic exam of ur		\$4		
81015	TC	Microscopic exam of ur		\$6		
81020		Urinalysis, glass test		BR		
81025		Urine pregnancy test		\$8		

LABOR AND EMPLOYMENT

CPT Code	Mod	Description	Global Days	Maximum Allowance	Non-Facility Maximum	Facility Maximum
81025	26	Urine pregnancy test		\$4		
81025	TC	Urine pregnancy test		\$4		
81050		Urinalysis, volume mea		BR		
81050	26	Urinalysis, volume mea		BR		
81050	TC	Urinalysis, volume mea		BR		
81099		Urinalysis test proced		BR		
81099	26	Urinalysis test proced		BR		
81099	TC	Urinalysis test proced		BR		
82000		Assay blood acetaldehy		\$47		
82000	26	Assay blood acetaldehy		\$14		
82000	TC	Assay blood acetaldehy		\$33		
82003		Assay acetaminophen		\$67		
82003	26	Assay acetaminophen		\$18		
82003	TC	Assay acetaminophen		\$49		
82009		Test for acetone/keton		\$18		
82009	26	Test for acetone/keton		\$6		
82009	TC	Test for acetone/keton		\$12		
82010		Acetone assay		\$43		
82010	26	Acetone assay		\$14		
82010	TC	Acetone assay		\$29		
82013		Acetylcholinesterase a		\$47		
82013	26	Acetylcholinesterase a		\$14		
82013	TC	Acetylcholinesterase a		\$33		
82016		Acylcarnitines, qual..		BR		
82017		Acylcarnitines, quant		BR		
82024		ACTH		\$143		
82024	26	ACTH		\$43		
82024	TC	ACTH		\$100		
82030		ADP & AMP		\$82		
82030	26	ADP & AMP		\$33		
82030	TC	ADP & AMP		\$49		
82040		Assay serum albumin		\$20		
82040	26	Assay serum albumin		\$6		
82040	TC	Assay serum albumin		\$14		
82042		Assay urine albumin		\$22		
82042	26	Assay urine albumin		\$6		
82042	TC	Assay urine albumin		\$16		
82043		Microalbumin, quantita		BR		
82043	26	Microalbumin, quantita		BR		
82043	TC	Microalbumin, quantita		BR		
82044		Microalbumin, semiquan		BR		
82044	26	Microalbumin, semiquan		BR		
82044	TC	Microalbumin, semiquan		BR		
82055		Assay ethanol		\$61		
82055	26	Assay ethanol		\$18		
82055	TC	Assay ethanol		\$43		
82075		Assay breath ethanol		\$59		
82075	26	Assay breath ethanol		\$18		
82075	TC	Assay breath ethanol		\$41		
82085		Assay of aldolase		\$47		
82085	26	Assay of aldolase		\$14		
82085	TC	Assay of aldolase		\$33		
82088		Aldosterone		\$169		
82088	26	Aldosterone		\$53		
82088	TC	Aldosterone		\$116		
82101		Assay of urine alkaloi		\$112		
82101	26	Assay of urine alkaloi		\$35		
82101	TC	Assay of urine alkaloi		\$77		
82103		Alpha-1-antitrypsin, t		BR		
82103	26	Alpha-1-antitrypsin, t		BR		
82103	TC	Alpha-1-antitrypsin, t		BR		
82104		Alpha-1-antitrypsin, p		BR		
82104	26	Alpha-1-antitrypsin, p		BR		
82104	TC	Alpha-1-antitrypsin, p		BR		
82105		Alpha-fetoprotein, ser		BR		
82105	26	Alpha-fetoprotein, ser		BR		



Title 40, Part I

CPT Code	Mod	Description	Global Days	Maximum Allowance	Non-Facility Maximum	Facility Maximum
82105	TC	Alpha-fetoprotein, ser		BR		
82106		Alpha-fetoprotein; amn		BR		
82106	26	Alpha-fetoprotein; amn		BR		
82106	TC	Alpha-fetoprotein; amn		BR		
82108		Assay, aluminum		\$85		
82108	26	Assay, aluminum		\$26		
82108	TC	Assay, aluminum		\$59		
82120		Amines, vaginal fluid qual		BR		
82127		Amino acid, single qual		\$54		
82127	26	Amino acid, single qual		\$14		
82127	TC	Amino acid, single qual		\$40		
82128		Amino acids, mult qual		\$54		
82128	26	Amino acids, mult qual		\$14		
82128	TC	Amino acids, mult qual		\$40		
82131		Amino acids, single quant		BR		
82131	26	Amino acids, single quant		BR		
82131	TC	Amino acids, single quant		BR		
82135		Assay, aminolevulinic		\$77		
82135	26	Assay, aminolevulinic		\$24		
82135	TC	Assay, aminolevulinic		\$53		
82136		Amino acids, quant, 2- 5		BR		
82136	26	Amino acids, quant, 2- 5		BR		
82136	TC	Amino acids, quant, 2- 5		BR		
82139		Amino acids, quan, 6 or more		BR		
82139	26	Amino acids, quan, 6 or more		BR		
82139	TC	Amino acids, quan, 6 or more		BR		
82140		Assay of ammonia		\$75		
82140	26	Assay of ammonia		\$22		
82140	TC	Assay of ammonia		\$53		
82143		Amniotic fluid scan		\$53		
82143	26	Amniotic fluid scan		\$16		
82143	TC	Amniotic fluid scan		\$37		
82145		Assay of amphetamines		\$65		
82145	26	Assay of amphetamines		\$18		
82145	TC	Assay of amphetamines		\$47		
82150		Assay of amylase		\$30		
82150	26	Assay of amylase		\$10		
82150	TC	Assay of amylase		\$20		
82154		Androstenediol glucuro		BR		
82154	26	Androstenediol glucuro		BR		
82154	TC	Androstenediol glucuro		BR		
82157		Assay of androstenedio		\$108		
82157	26	Assay of androstenedio		\$33		
82157	TC	Assay of androstenedio		\$75		
82160		Androsterone assay		\$122		
82160	26	Androsterone assay		\$41		
82160	TC	Androsterone assay		\$81		
82163		Assay of angiotensin I		\$79		
82163	26	Assay of angiotensin I		\$22		
82163	TC	Assay of angiotensin I		\$57		
82164		Angiotensin I enzyme t		\$59		
82164	26	Angiotensin I enzyme t		\$18		
82164	TC	Angiotensin I enzyme t		\$41		
82172		Apolipoprotein		\$65		
82172	26	Apolipoprotein		\$20		
82172	TC	Apolipoprotein		\$45		
82175		Assay of arsenic		\$90		
82175	26	Assay of arsenic		\$29		
82175	TC	Assay of arsenic		\$61		
82180		Assay of ascorbic acid		\$49		
82180	26	Assay of ascorbic acid		\$16		
82180	TC	Assay of ascorbic acid		\$33		
82190		Atomic absorption		BR		
82190	26	Atomic absorption		BR		
82190	TC	Atomic absorption		BR		
82205		Assay of barbiturates		\$63		

LABOR AND EMPLOYMENT

CPT Code	Mod	Description	Global Days	Maximum Allowance	Non-Facility Maximum	Facility Maximum
82205	26	Assay of barbiturates		\$18		
82205	TC	Assay of barbiturates		\$45		
82232		Beta-2 protein		\$81		
82232	26	Beta-2 protein		\$26		
82232	TC	Beta-2 protein		\$55		
82239		Bile acids, total		BR		
82239	26	Bile acids, total		BR		
82239	TC	Bile acids, total		BR		
82240		Bile acids, cholyglyc		\$92		
82240	26	Bile acids, cholyglyc		\$29		
82240	TC	Bile acids, cholyglyc		\$63		
82247		Bilirubin, total.....		BR		
82247	26	Bilirubin, total.....		BR		
82247	TC	Bilirubin, total.....		BR		
82248		Bilirubin, direct.....		BR		
82248	26	Bilirubin, direct.....		BR		
82248	TC	Bilirubin, direct.....		BR		
82252		Fecal bilirubin test		\$20		
82252	26	Fecal bilirubin test		\$6		
82252	TC	Fecal bilirubin test		\$14		
82261		Assay of biotinidase..		BR		
82270		Test for blood, feces		\$12		
82270	26	Test for blood, feces		\$5		
82270	TC	Test for blood, feces		\$7		
82286		Assay of bradykinin		\$22		
82286	26	Assay of bradykinin		\$6		
82286	TC	Assay of bradykinin		\$16		
82300		Assay cadmium		\$90		
82300	26	Assay cadmium		\$29		
82300	TC	Assay cadmium		\$61		
82306		Assay of vitamin D		\$147		
82306	26	Assay of vitamin D		\$49		
82306	TC	Assay of vitamin D		\$98		
82308		Assay of calcitonin		\$116		
82308	26	Assay of calcitonin		\$35		
82308	TC	Assay of calcitonin		\$81		
82310		Assay calcium		\$20		
82310	26	Assay calcium		\$6		
82310	TC	Assay calcium		\$14		
82330		Assay calcium		\$69		
82330	26	Assay calcium		\$20		
82330	TC	Assay calcium		\$49		
82331		Calcium infusion test		\$26		
82331	26	Calcium infusion test		\$8		
82331	TC	Calcium infusion test		\$18		
82340		Assay calcium in urine		\$24		
82340	26	Assay calcium in urine		\$8		
82340	TC	Assay calcium in urine		\$16		
82355		Calculus (stone) analy		\$57		
82355	26	Calculus (stone) analy		\$18		
82355	TC	Calculus (stone) analy		\$39		
82360		Calculus (stone) assay		\$57		
82360	26	Calculus (stone) assay		\$18		
82360	TC	Calculus (stone) assay		\$39		
82365		Calculus (stone) assay		\$57		
82365	26	Calculus (stone) assay		\$16		
82365	TC	Calculus (stone) assay		\$41		
82370		X-ray assay, calculus		\$43		
82370	26	X-ray assay, calculus		\$14		
82370	TC	X-ray assay, calculus		\$29		
82374		Assay blood carbon dio		\$18		
82374	26	Assay blood carbon dio		\$6		
82374	TC	Assay blood carbon dio		\$12		
82375		Assay blood carbon mon		\$63		
82375	26	Assay blood carbon mon		\$18		
82375	TC	Assay blood carbon mon		\$45		

Title 40, Part I

CPT Code	Mod	Description	Global Days	Maximum Allowance	Non-Facility Maximum	Facility Maximum
82376		Test for carbon monoxi		\$20		
82376	26	Test for carbon monoxi		\$6		
82376	TC	Test for carbon monoxi		\$14		
82378		Carcinoembryonic antig		BR		
82378	26	Carcinoembryonic antig		BR		
82378	TC	Carcinoembryonic antig		BR		
82379		Assay of carnitine....		BR		
82380		Assay carotene		\$41		
82380	26	Assay carotene		\$12		
82380	TC	Assay carotene		\$29		
82382		Assay urine catecholam		\$71		
82382	26	Assay urine catecholam		\$22		
82382	TC	Assay urine catecholam		\$49		
82383		Assay blood catecholam		\$116		
82383	26	Assay blood catecholam		\$35		
82383	TC	Assay blood catecholam		\$81		
82384		Assay three catecholam		\$116		
82384	26	Assay three catecholam		\$35		
82384	TC	Assay three catecholam		\$81		
82387		Cathepsin-D		BR		
82387	26	Cathepsin-D		BR		
82387	TC	Cathepsin-D		BR		
82390		Assay ceruloplasmin		\$47		
82390	26	Assay ceruloplasmin		\$14		
82390	TC	Assay ceruloplasmin		\$33		
82397		Chemiluminescent assay		BR		
82397	26	Chemiluminescent assay		BR		
82397	TC	Chemiluminescent assay		BR		
82415		Assay chloramphenicol		\$53		
82415	26	Assay chloramphenicol		\$16		
82415	TC	Assay chloramphenicol		\$37		
82435		Assay blood chloride		\$16		
82435	26	Assay blood chloride		\$4		
82435	TC	Assay blood chloride		\$12		
82436		Assay urine chloride		\$26		
82436	26	Assay urine chloride		\$8		
82436	TC	Assay urine chloride		\$18		
82438		Assay other fluid chlo		\$24		
82438	26	Assay other fluid chlo		\$8		
82438	TC	Assay other fluid chlo		\$16		
82441		Test for chlorohydroca		\$30		
82441	26	Test for chlorohydroca		\$10		
82441	TC	Test for chlorohydroca		\$20		
82465		Assay serum cholesteo		\$16		
82465	26	Assay serum cholesteo		\$4		
82465	TC	Assay serum cholesteo		\$12		
82480		Assay serum cholineste		\$45		
82480	26	Assay serum cholineste		\$12		
82480	TC	Assay serum cholineste		\$33		
82482		Assay rbc cholinestera		\$53		
82482	26	Assay rbc cholinestera		\$16		
82482	TC	Assay rbc cholinestera		\$37		
82485		Assay chondroitin sulf		\$69		
82485	26	Assay chondroitin sulf		\$16		
82485	TC	Assay chondroitin sulf		\$53		
82486		Gas/liquid chromatography		\$79		
82486	26	Gas/liquid chromatography		\$26		
82486	TC	Gas/liquid chromatography		\$53		
82487		Paper chromatography		\$81		
82487	26	Paper chromatography		\$26		
82487	TC	Paper chromatography		\$55		
82488		Paper chromatography		\$108		
82488	26	Paper chromatography		\$37		
82488	TC	Paper chromatography		\$71		
82489		Thin layer chromatogra		\$88		
82489	26	Thin layer chromatogra		\$29		

LABOR AND EMPLOYMENT

CPT Code	Mod	Description	Global Days	Maximum Allowance	Non-Facility Maximum	Facility Maximum
82489	TC	Thin layer chromatogra		\$59		
82491		Chromotography, quant, sing		BR		
82491	26	Chromotography, quant, sing		BR		
82491	TC	Chromotography, quant, sing		BR		
82492		Chromotography, quant, sing mult		BR		
82495		Assay chromium		\$90		
82495	26	Assay chromium		\$31		
82495	TC	Assay chromium		\$59		
82507		Assay citrate		\$104		
82507	26	Assay citrate		\$31		
82507	TC	Assay citrate		\$73		
82520		Assay for cocaine		\$51		
82520	26	Assay for cocaine		\$16		
82520	TC	Assay for cocaine		\$35		
82523		Collagen crosslinks...		BR		
82525		Assay copper		\$63		
82525	26	Assay copper		\$18		
82525	TC	Assay copper		\$45		
82528		Assay corticosterone		\$75		
82528	26	Assay corticosterone		\$24		
82528	TC	Assay corticosterone		\$51		
82530		Cortisol, free		BR		
82530	26	Cortisol, free		BR		
82530	TC	Cortisol, free		BR		
82533		Total cortisol		\$65		
82533	26	Total cortisol		\$18		
82533	TC	Total cortisol		\$47		
82540		Assay creatine		\$18		
82540	26	Assay creatine		\$6		
82540	TC	Assay creatine		\$12		
82541		Column chromatography, qual		BR		
82542		Column chromatography, quant		BR		
82543		Column chromatograph/ isotope		BR		
82544		Column chromatograph/isotope		BR		
82550		Assay CK (CPK)		\$30		
82550	26	Assay CK (CPK)		\$8		
82550	TC	Assay CK (CPK)		\$22		
82552		Assay CPK in blood		\$61		
82552	26	Assay CPK in blood		\$18		
82552	TC	Assay CPK in blood		\$43		
82553		Creatine, MB fraction		BR		
82553	26	Creatine, MB fraction		BR		
82553	TC	Creatine, MB fraction		BR		
82554		Creatine, isoforms		BR		
82554	26	Creatine, isoforms		BR		
82554	TC	Creatine, isoforms		BR		
82565		Assay creatinine		\$24		
82565	26	Assay creatinine		\$4		
82565	TC	Assay creatinine		\$20		
82570		Assay urine creatinine		\$24		
82570	26	Assay urine creatinine		\$6		
82570	TC	Assay urine creatinine		\$18		
82575		Creatinine clearance t		\$49		
82575	26	Creatinine clearance t		\$16		
82575	TC	Creatinine clearance t		\$33		
82585		Assay cryofibrinogen		\$28		
82585	26	Assay cryofibrinogen		\$6		
82585	TC	Assay cryofibrinogen		\$22		
82595		Assay cryoglobulin		\$32		
82595	26	Assay cryoglobulin		\$10		
82595	TC	Assay cryoglobulin		\$22		
82600		Assay cyanide		\$75		
82600	26	Assay cyanide		\$22		
82600	TC	Assay cyanide		\$53		
82607		Vitamin B-12		\$77		
82607	26	Vitamin B-12		\$22		

Title 40, Part I

CPT Code	Mod	Description	Global Days	Maximum Allowance	Non-Facility Maximum	Facility Maximum
82607	TC	Vitamin B-12		\$55		
82608		B-12 binding capacity		\$75		
82608	26	B-12 binding capacity		\$24		
82608	TC	B-12 binding capacity		\$51		
82615		Test for urine cystine		\$32		
82615	26	Test for urine cystine		\$10		
82615	TC	Test for urine cystine		\$22		
82626		Dehydroepiandrosterone		\$112		
82626	26	Dehydroepiandrosterone		\$37		
82626	TC	Dehydroepiandrosterone		\$75		
82627		Dehydroepiandrosterone		BR		
82627	26	Dehydroepiandrosterone		BR		
82627	TC	Dehydroepiandrosterone		BR		
82633		Desoxycorticosterone		\$151		
82633	26	Desoxycorticosterone		\$45		
82633	TC	Desoxycorticosterone		\$106		
82634		Deoxycortisol		\$151		
82634	26	Deoxycortisol		\$45		
82634	TC	Deoxycortisol		\$106		
82638		Assay dibucaine number		\$45		
82638	26	Assay dibucaine number		\$14		
82638	TC	Assay dibucaine number		\$31		
82646		Assay of dihydrocodein		\$69		
82646	26	Assay of dihydrocodein		\$20		
82646	TC	Assay of dihydrocodein		\$49		
82649		Assay of dihydromorphi		\$82		
82649	26	Assay of dihydromorphi		\$33		
82649	TC	Assay of dihydromorphi		\$49		
82651		Dihydrotestosterone as		\$82		
82651	26	Dihydrotestosterone as		\$33		
82651	TC	Dihydrotestosterone as		\$49		
82652		Assay, dihydroxyvitami		\$165		
82652	26	Assay, dihydroxyvitami		\$49		
82652	TC	Assay, dihydroxyvitami		\$116		
82654		Assay of dimethadione		\$69		
82654	26	Assay of dimethadione		\$20		
82654	TC	Assay of dimethadione		\$49		
82657		Enzyme cell activity..		BR		
82658		Enzyme cell activity, ra.		BR		
82664		Electrophoretic test		\$75		
82664	26	Electrophoretic test		\$24		
82664	TC	Electrophoretic test		\$51		
82666		Epiandrosterone assay		\$110		
82666	26	Epiandrosterone assay		\$33		
82666	TC	Epiandrosterone assay		\$77		
82668		Erythropoietin		\$85		
82668	26	Erythropoietin		\$26		
82668	TC	Erythropoietin		\$59		
82670		Estradiol		\$114		
82670	26	Estradiol		\$35		
82670	TC	Estradiol		\$79		
82671		Estrogens assay		\$114		
82671	26	Estrogens assay		\$33		
82671	TC	Estrogens assay		\$81		
82672		Estrogen assay		\$108		
82672	26	Estrogen assay		\$31		
82672	TC	Estrogen assay		\$77		
82677		Estriol		\$98		
82677	26	Estriol		\$33		
82677	TC	Estriol		\$65		
82679		Estrone		\$129		
82679	26	Estrone		\$39		
82679	TC	Estrone		\$90		
82690		Ethchlorvynol		\$100		
82690	26	Ethchlorvynol		\$41		
82690	TC	Ethchlorvynol		\$59		

LABOR AND EMPLOYMENT

CPT Code	Mod	Description	Global Days	Maximum Allowance	Non-Facility Maximum	Facility Maximum
82693		Ethylene glycol		BR		
82693	26	Ethylene glycol		BR		
82693	TC	Ethylene glycol		BR		
82696		Etiocholanolone		\$108		
82696	26	Etiocholanolone		\$37		
82696	TC	Etiocholanolone		\$71		
82705		Fats/lipids,feces,qual		\$26		
82705	26	Fats/lipids,feces,qual		\$10		
82705	TC	Fats/lipids,feces,qual		\$16		
82710		Fats/lipids,feces,quan		\$79		
82710	26	Fats/lipids,feces,quan		\$24		
82710	TC	Fats/lipids,feces,quan		\$55		
82715		Fecal fat assay		\$61		
82715	26	Fecal fat assay		\$20		
82715	TC	Fecal fat assay		\$41		
82725		Assay blood fatty acid		\$53		
82725	26	Assay blood fatty acid		\$16		
82725	TC	Assay blood fatty acid		\$37		
82726		Long chain fatty acids		BR		
82728		Assay ferritin		\$47		
82728	26	Assay ferritin		\$14		
82728	TC	Assay ferritin		\$33		
82731		Assay of fetal fibronectin.		BR		
82735		Assay fluoride		\$67		
82735	26	Assay fluoride		\$22		
82735	TC	Assay fluoride		\$45		
82742		Assay of flurazepam		\$79		
82742	26	Assay of flurazepam		\$24		
82742	TC	Assay of flurazepam		\$55		
82746		Blood folic acid serum		\$73		
82746	26	Blood folic acid serum		\$24		
82746	TC	Blood folic acid serum		\$49		
82747		Folic acid, RBC		BR		
82747	26	Folic acid, RBC		BR		
82747	TC	Folic acid, RBC		BR		
82757		Assay semen fructose		\$67		
82757	26	Assay semen fructose		\$20		
82757	TC	Assay semen fructose		\$47		
82759		RBC galactokinase assay		\$71		
82759	26	RBC galactokinase assay		\$22		
82759	TC	RBC galactokinase assay		\$49		
82760		Assay galactose		\$51		
82760	26	Assay galactose		\$16		
82760	TC	Assay galactose		\$35		
82775		Assay galactose transf		\$87		
82775	26	Assay galactose transf		\$26		
82775	TC	Assay galactose transf		\$61		
82776		Galactose transferase		\$26		
82776	26	Galactose transferase		\$6		
82776	TC	Galactose transferase		\$20		
82784		Assay gammaglobulin Ig		\$28		
82784	26	Assay gammaglobulin Ig		\$8		
82784	TC	Assay gammaglobulin Ig		\$20		
82785		Assay, gammaglobulin I		\$61		
82785	26	Assay, gammaglobulin I		\$20		
82785	TC	Assay, gammaglobulin I		\$41		
82787		IgG1, 2, 3 and 4		BR		
82787	26	IgG1, 2, 3 and 4		BR		
82787	TC	IgG1, 2, 3 and 4		BR		
82800		Blood pH		\$43		
82800	26	Blood pH		\$12		
82800	TC	Blood pH		\$31		
82803		Blood gases: pH, pO2 &		\$100		
82803	26	Blood gases: pH, pO2 &		\$31		
82803	TC	Blood gases: pH, pO2 &		\$69		
82805		Blood gases W/02 satur		\$53		

Title 40, Part I

CPT Code	Mod	Description	Global Days	Maximum Allowance	Non-Facility Maximum	Facility Maximum
82805	26	Blood gases W/O2 satur		\$16		
82805	TC	Blood gases W/O2 satur		\$37		
82810		Blood gases, O2 sat on		\$53		
82810	26	Blood gases, O2 sat on		\$16		
82810	TC	Blood gases, O2 sat on		\$37		
82820		Hemoglobin-oxygen affi		BR		
82820	26	Hemoglobin-oxygen affi		BR		
82820	TC	Hemoglobin-oxygen affi		BR		
82938		Gastrin test		\$90		
82938	26	Gastrin test		\$31		
82938	TC	Gastrin test		\$59		
82941		Assay of gastrin		\$88		
82941	26	Assay of gastrin		\$29		
82941	TC	Assay of gastrin		\$59		
82943		Assay of glucagon		\$71		
82943	26	Assay of glucagon		\$22		
82943	TC	Assay of glucagon		\$49		
82946		Glucagon tolerance test		\$55		
82946	26	Glucagon tolerance test		\$14		
82946	TC	Glucagon tolerance test		\$41		
82947		Assay quantitative, gl		\$20		
82947	26	Assay quantitative, gl		\$6		
82947	TC	Assay quantitative, gl		\$14		
82948		Reagent strip/blood gl		\$10		
82948	26	Reagent strip/blood gl		\$4		
82948	TC	Reagent strip/blood gl		\$6		
82950		Glucose test		\$22		
82950	26	Glucose test		\$8		
82950	TC	Glucose test		\$14		
82951		Glucose tolerance test		\$43		
82951	26	Glucose tolerance test		\$14		
82951	TC	Glucose tolerance test		\$29		
82952		GTT-added samples		\$20		
82952	26	GTT-added samples		\$6		
82952	TC	GTT-added samples		\$14		
82953		Glucose-tolbutamide test		\$77		
82953	26	Glucose-tolbutamide test		\$26		
82953	TC	Glucose-tolbutamide test		\$51		
82955		Assay G6PD enzyme		\$49		
82955	26	Assay G6PD enzyme		\$14		
82955	TC	Assay G6PD enzyme		\$35		
82960		Test for G6PD enzyme		\$26		
82960	26	Test for G6PD enzyme		\$8		
82960	TC	Test for G6PD enzyme		\$18		
82962		Glucose blood test		BR		
82962	26	Glucose blood test		BR		
82962	TC	Glucose blood test		BR		
82963		Glucosidase assay		\$102		
82963	26	Glucosidase assay		\$33		
82963	TC	Glucosidase assay		\$69		
82965		Assay GDH enzyme		\$36		
82965	26	Assay GDH enzyme		\$12		
82965	TC	Assay GDH enzyme		\$24		
82975		Assay glutamine		\$53		
82975	26	Assay glutamine		\$16		
82975	TC	Assay glutamine		\$37		
82977		Assay of GGT		\$30		
82977	26	Assay of GGT		\$8		
82977	TC	Assay of GGT		\$22		
82978		Glutathione assay		\$49		
82978	26	Glutathione assay		\$14		
82978	TC	Glutathione assay		\$35		
82979		Assay RBC glutathione		\$34		
82979	26	Assay RBC glutathione		\$10		
82979	TC	Assay RBC glutathione		\$24		
82980		Assay of glutethimide		\$79		

LABOR AND EMPLOYMENT

CPT Code	Mod	Description	Global Days	Maximum Allowance	Non-Facility Maximum	Facility Maximum
82980	26	Assay of glutethimide		\$18		
82980	TC	Assay of glutethimide		\$61		
82985		Glycated protein		\$77		
82985	26	Glycated protein		\$22		
82985	TC	Glycated protein		\$55		
83001		Gonadotropin (FSH)		\$75		
83001	26	Gonadotropin (FSH)		\$22		
83001	TC	Gonadotropin (FSH)		\$53		
83002		Gonadotropin (LH)		\$79		
83002	26	Gonadotropin (LH)		\$24		
83002	TC	Gonadotropin (LH)		\$55		
83003		Assay growth hormone		\$67		
83003	26	Assay growth hormone		\$18		
83003	TC	Assay growth hormone		\$49		
83008		Assay guanosine		\$63		
83008	26	Assay guanosine		\$18		
83008	TC	Assay guanosine		\$45		
83010		Quant assay haptoglobi		\$51		
83010	26	Quant assay haptoglobi		\$16		
83010	TC	Quant assay haptoglobi		\$35		
83012		Assay haptoglobins		\$67		
83012	26	Assay haptoglobins		\$26		
83012	TC	Assay haptoglobins		\$41		
83013		H pylori breath tst analysis.		BR		
83014		H pylori drug admin/collect		BR		
83015		Heavy metal screen		\$96		
83015	26	Heavy metal screen		\$29		
83015	TC	Heavy metal screen		\$67		
83018		Quantitative screen, m		\$106		
83018	26	Quantitative screen, m		\$31		
83018	TC	Quantitative screen, m		\$75		
83020		Hemoglobin electrophoresis		\$78		
83020	26	Hemoglobin electrophoresis		\$40		
83020	TC	Hemoglobin electrophoresis		\$38		
83021		Hemoglobin chromatography		BR		
83026		Hemoglobin, copper sul		BR		
83026	26	Hemoglobin, copper sul		BR		
83026	TC	Hemoglobin, copper sul		BR		
83030		Fetal hemoglobin assay		\$34		
83030	26	Fetal hemoglobin assay		\$12		
83030	TC	Fetal hemoglobin assay		\$22		
83033		Fetal fecal hemoglobin		\$28		
83033	26	Fetal fecal hemoglobin		\$8		
83033	TC	Fetal fecal hemoglobin		\$20		
83036		Glycated hemoglobin test		\$28		
83036	26	Glycated hemoglobin test		\$10		
83036	TC	Glycated hemoglobin test		\$18		
83045		Blood methemoglobin test		\$24		
83045	26	Blood methemoglobin test		\$8		
83045	TC	Blood methemoglobin test		\$16		
83050		Blood methemoglobin assay		\$36		
83050	26	Blood methemoglobin assay		\$12		
83050	TC	Blood methemoglobin as		\$24		
83051		Assay plasma hemoglobin		\$36		
83051	26	Assay plasma hemoglobin		\$12		
83051	TC	Assay plasma hemoglobin		\$24		
83055		Blood sulfhemoglobin test		\$24		
83055	26	Blood sulfhemoglobin test		\$8		
83055	TC	Blood sulfhemoglobin test		\$16		
83060		Blood sulfhemoglobin a		\$43		
83060	26	Blood sulfhemoglobin a		\$12		
83060	TC	Blood sulfhemoglobin a		\$31		
83065		Hemoglobin heat assay		\$34		
83065	26	Hemoglobin heat assay		\$12		
83065	TC	Hemoglobin heat assay		\$22		
83068		Hemoglobin stability s		\$39		



Title 40, Part I

CPT Code	Mod	Description	Global Days	Maximum Allowance	Non-Facility Maximum	Facility Maximum
83068	26	Hemoglobin stability s		\$10		
83068	TC	Hemoglobin stability s		\$29		
83069		Assay urine hemoglobin		\$20		
83069	26	Assay urine hemoglobin		\$6		
83069	TC	Assay urine hemoglobin		\$14		
83070		Qualt assay hemosideri		\$24		
83070	26	Qualt assay hemosideri		\$8		
83070	TC	Qualt assay hemosideri		\$16		
83071		Quant assay of hemosid		\$34		
83071	26	Quant assay of hemosid		\$10		
83071	TC	Quant assay of hemosid		\$24		
83080		Assay of b hexosaminidase		BR		
83088		Assay histamine		\$112		
83088	26	Assay histamine		\$35		
83088	TC	Assay histamine		\$77		
83150		Assay for HVA		\$92		
83150	26	Assay for HVA		\$31		
83150	TC	Assay for HVA		\$61		
83491		Assay of corticosteroi		\$69		
83491	26	Assay of corticosteroi		\$20		
83491	TC	Assay of corticosteroi		\$49		
83497		Assay 5-HIAA		\$65		
83497	26	Assay 5-HIAA		\$20		
83497	TC	Assay 5-HIAA		\$45		
83498		Assay of progesterone		\$116		
83498	26	Assay of progesterone		\$39		
83498	TC	Assay of progesterone		\$77		
83499		Assay of progesterone		\$96		
83499	26	Assay of progesterone		\$29		
83499	TC	Assay of progesterone		\$67		
83500		Assay free hydroxyprol		\$127		
83500	26	Assay free hydroxyprol		\$41		
83500	TC	Assay free hydroxyprol		\$86		
83505		Assay total hydroxypro		\$143		
83505	26	Assay total hydroxypro		\$41		
83505	TC	Assay total hydroxypro		\$102		
83516		Immunoassay, nonantibody		BR		
83518		Immunoassay, dipstick		BR		
83518	26	Immunoassay, dipstick		BR		
83518	TC	Immunoassay, dipstick		BR		
83519		Immunoassay, nonantibody		BR		
83519	26	Immunoassay, nonantibody		BR		
83519	TC	Immunoassay, nonantibody		BR		
83520		Immunoassay, RIA		BR		
83520	26	Immunoassay, RIA		BR		
83520	TC	Immunoassay, RIA		BR		
83525		Assay of insulin		\$57		
83525	26	Assay of insulin		\$16		
83525	TC	Assay of insulin		\$41		
83527		Assay of insulin		\$65		
83527	26	Assay of insulin		\$20		
83527	TC	Assay of insulin		\$45		
83528		Assay intrinsic factor		\$81		
83528	26	Assay intrinsic factor		\$26		
83528	TC	Assay intrinsic factor		\$55		
83540		Assay iron		\$32		
83540	26	Assay iron		\$8		
83540	TC	Assay iron		\$24		
83550		Iron binding test		\$39		
83550	26	Iron binding test		\$10		
83550	TC	Iron binding test		\$29		
83570		Assay IDH enzyme		\$45		
83570	26	Assay IDH enzyme		\$14		
83570	TC	Assay IDH enzyme		\$31		
83582		Assay ketogenic steroi		\$63		
83582	26	Assay ketogenic steroi		\$16		

LABOR AND EMPLOYMENT

CPT Code	Mod	Description	Global Days	Maximum Allowance	Non-Facility Maximum	Facility Maximum
83582	TC	Assay ketogenic steroi		\$47		
83586		Assay 17-(17-KS)ketost		\$71		
83586	26	Assay 17-(17-KS)ketost		\$24		
83586	TC	Assay 17-(17-KS)ketost		\$47		
83593		Fractionation ketoster		\$112		
83593	26	Fractionation ketoster		\$35		
83593	TC	Fractionation ketoster		\$77		
83605		Lactic acid assay		\$36		
83605	26	Lactic acid assay		\$12		
83605	TC	Lactic acid assay		\$24		
83615		Lactate (LD) (LDH) enz		\$30		
83615	26	Lactate (LD) (LDH) enz		\$10		
83615	TC	Lactate (LD) (LDH) enz		\$20		
83625		Assay LDH enzymes		\$45		
83625	26	Assay LDH enzymes		\$12		
83625	TC	Assay LDH enzymes		\$33		
83632		Placental lactogen		\$79		
83632	26	Placental lactogen		\$26		
83632	TC	Placental lactogen		\$53		
83633		Test urine for lactose		\$28		
83633	26	Test urine for lactose		\$8		
83633	TC	Test urine for lactose		\$20		
83634		Assay urine for lactos		\$59		
83634	26	Assay urine for lactos		\$18		
83634	TC	Assay urine for lactos		\$41		
83655		Assay for lead		\$57		
83655	26	Assay for lead		\$16		
83655	TC	Assay for lead		\$41		
83661		Assay L/S ratio		\$32		
83661	26	Assay L/S ratio		\$10		
83661	TC	Assay L/S ratio		\$22		
83662		L/S ratio, foam stabil		BR		
83662	26	L/S ratio, foam stabil		BR		
83662	TC	L/S ratio, foam stabil		BR		
83670		Assay LAP enzyme		\$34		
83670	26	Assay LAP enzyme		\$10		
83670	TC	Assay LAP enzyme		\$24		
83690		Assay lipase		\$34		
83690	26	Assay lipase		\$12		
83690	TC	Assay lipase		\$22		
83718		Blood lipoprotein assa		\$36		
83718	26	Blood lipoprotein assa		\$10		
83718	TC	Blood lipoprotein assa		\$26		
83719		Assay of blood lipoprotein		\$51		
83719	26	Assay of blood lipoprotein		\$17		
83719	TC	Assay of blood lipoprotein		\$34		
83721		Assay of blood lipoprotein		BR		
83721	26	Assay of blood lipoprotein		BR		
83721	TC	Assay of blood lipoprotein		BR		
83727		LRH hormone assay		\$81		
83727	26	LRH hormone assay		\$26		
83727	TC	LRH hormone assay		\$55		
83735		Assay magnesium		\$28		
83735	26	Assay magnesium		\$10		
83735	TC	Assay magnesium		\$18		
83775		Assay of md enzyme		\$32		
83775	26	Assay of md enzyme		\$10		
83775	TC	Assay of md enzyme		\$22		
83785		Assay of manganese		\$110		
83785	26	Assay of manganese		\$33		
83785	TC	Assay of manganese		\$77		
83788		Mass spectrometry qual		BR		
83789		Mass spectrometry quant		BR		
83805		Assay of meprobamate		\$84		
83805	26	Assay of meprobamate		\$29		
83805	TC	Assay of meprobamate		\$55		

Title 40, Part I

CPT Code	Mod	Description	Global Days	Maximum Allowance	Non-Facility Maximum	Facility Maximum
83825		Assay mercury		\$63		
83825	26	Assay mercury		\$20		
83825	TC	Assay mercury		\$43		
83835		Assay metanephrines		\$77		
83835	26	Assay metanephrines		\$22		
83835	TC	Assay metanephrines		\$55		
83840		Assay methadone		\$79		
83840	26	Assay methadone		\$26		
83840	TC	Assay methadone		\$53		
83857		Assay methemalbumin		\$51		
83857	26	Assay methemalbumin		\$16		
83857	TC	Assay methemalbumin		\$35		
83858		Assay methsuximide		\$69		
83858	26	Assay methsuximide		\$22		
83858	TC	Assay methsuximide		\$47		
83864		Mucopolysaccharides		\$59		
83864	26	Mucopolysaccharides		\$16		
83864	TC	Mucopolysaccharides		\$43		
83866		Mucopolysaccharides sc		\$51		
83866	26	Mucopolysaccharides sc		\$14		
83866	TC	Mucopolysaccharides sc		\$37		
83872		Assay synovial fluid m		\$24		
83872	26	Assay synovial fluid m		\$8		
83872	TC	Assay synovial fluid m		\$16		
83873		Assay, CSF protein		\$102		
83873	26	Assay, CSF protein		\$35		
83873	TC	Assay, CSF protein		\$67		
83874		Myoglobin		\$49		
83874	26	Myoglobin		\$16		
83874	TC	Myoglobin		\$33		
83883		Nephelometry, not spec		BR		
83883	26	Nephelometry, not spec		BR		
83883	TC	Nephelometry, not spec		BR		
83885		Assay for nickel		\$85		
83885	26	Assay for nickel		\$26		
83885	TC	Assay for nickel		\$59		
83887		Assay nicotine		\$110		
83887	26	Assay nicotine		\$33		
83887	TC	Assay nicotine		\$77		
83890		Molecule isolate.....		BR		
83890	26	Molecule isolate.....		BR		
83890	TC	Molecule isolate.....		BR		
83891		Molecule isolate nucleic.		BR		
83892		Molecular diagnostics		BR		
83892	26	Molecular diagnostics		BR		
83892	TC	Molecular diagnostics		BR		
83893		Molecule dot/slot/blot		BR		
83894		Molecule gel electrophor.		BR		
83894	26	Molecule gel electrophor.		BR		
83894	TC	Molecule gel electrophor.		BR		
83896		Molecular diagnostics		BR		
83896	26	Molecular diagnostics		BR		
83896	TC	Molecular diagnostics		BR		
83897		Molecule nucleic transfer		BR		
83898		Molecule nucleic ampli		BR		
83898	26	Molecule nucleic ampli		BR		
83898	TC	Molecule nucleic ampli		BR		
83901		Molecule nucleic ampli		BR		
83902		Molecular diagnostics		BR		
83903		Molecule mutation scan		BR		
83904		Molecule mutation identify		BR		
83905		Molecule mutation identify		BR		
83906		Molecule mutation identify		BR		
83912		Genetic examination		\$73		
83912	26	Genetic examination		\$20		
83912	TC	Genetic examination		\$53		

LABOR AND EMPLOYMENT

CPT Code	Mod	Description	Global Days	Maximum Allowance	Non-Facility Maximum	Facility Maximum
83915		Assay nucleotidase		\$57		
83915	26	Assay nucleotidase		\$18		
83915	TC	Assay nucleotidase		\$39		
83916		Oligoclonal bands		\$102		
83916	26	Oligoclonal bands		\$35		
83916	TC	Oligoclonal bands		\$67		
83918		Assay, organic acids quant		\$67		
83918	26	Assay, organic acids quant		\$19		
83918	TC	Assay, organic acids quant		\$48		
83919		Assay, organic acids qual		BR		
83925		Opiates		BR		
83925	26	Opiates		BR		
83925	TC	Opiates		BR		
83930		Assay blood osmolality		\$32		
83930	26	Assay blood osmolality		\$10		
83930	TC	Assay blood osmolality		\$22		
83935		Assay urine osmolality		\$32		
83935	26	Assay urine osmolality		\$10		
83935	TC	Assay urine osmolality		\$22		
83937		Assay for osteocalcin		BR		
83937	26	Assay for osteocalcin		BR		
83937	TC	Assay for osteocalcin		BR		
83945		Assay of oxalate ....		BR		
83970		Assay of parathormone		\$173		
83970	26	Assay of parathormone		\$57		
83970	TC	Assay of parathormone		\$116		
83986		Assay body fluid acidi		\$16		
83986	26	Assay body fluid acidi		\$6		
83986	TC	Assay body fluid acidi		\$10		
83992		Assay for phencyclidin		\$75		
83992	26	Assay for phencyclidin		\$22		
83992	TC	Assay for phencyclidin		\$53		
84022		Assay of phenothiazine		\$77		
84022	26	Assay of phenothiazine		\$24		
84022	TC	Assay of phenothiazine		\$53		
84030		Assay blood PKU		\$20		
84030	26	Assay blood PKU		\$6		
84030	TC	Assay blood PKU		\$14		
84035		Assay phenylketones		\$22		
84035	26	Assay phenylketones		\$6		
84035	TC	Assay phenylketones		\$16		
84060		Assay acid phosphatase		\$67		
84060	26	Assay acid phosphatase		\$22		
84060	TC	Assay acid phosphatase		\$45		
84061		Phosphatase, forensic		BR		
84061	26	Phosphatase, forensic		BR		
84061	TC	Phosphatase, forensic		BR		
84066		Assay prostate phospho		\$34		
84066	26	Assay prostate phospho		\$12		
84066	TC	Assay prostate phospho		\$22		
84075		Assay alkaline phospho		\$22		
84075	26	Assay alkaline phospho		\$6		
84075	TC	Assay alkaline phospho		\$16		
84078		Assay alkaline phospho		\$36		
84078	26	Assay alkaline phospho		\$10		
84078	TC	Assay alkaline phospho		\$26		
84080		Assay alkaline phospho		\$67		
84080	26	Assay alkaline phospho		\$20		
84080	TC	Assay alkaline phospho		\$47		
84081		Amniotic fluid enzyme		\$86		
84081	26	Amniotic fluid enzyme		\$29		
84081	TC	Amniotic fluid enzyme		\$57		
84085		Assay RBC PG6D enzyme		\$28		
84085	26	Assay RBC PG6D enzyme		\$10		
84085	TC	Assay RBC PG6D enzyme		\$18		
84087		Assay phosphohexose en		\$49		

Title 40, Part I

CPT Code	Mod	Description	Global Days	Maximum Allowance	Non-Facility Maximum	Facility Maximum
84087	26	Assay phosphohexose en		\$14		
84087	TC	Assay phosphohexose en		\$35		
84100		Assay phosphorus		\$20		
84100	26	Assay phosphorus		\$6		
84100	TC	Assay phosphorus		\$14		
84105		Assay urine phosphorus		\$20		
84105	26	Assay urine phosphorus		\$6		
84105	TC	Assay urine phosphorus		\$14		
84106		Test for porphobilinog		\$18		
84106	26	Test for porphobilinog		\$4		
84106	TC	Test for porphobilinog		\$14		
84110		Assay porphobilinogen		\$41		
84110	26	Assay porphobilinogen		\$12		
84110	TC	Assay porphobilinogen		\$29		
84119		Test urine for porphyr		\$41		
84119	26	Test urine for porphyr		\$12		
84119	TC	Test urine for porphyr		\$29		
84120		Assay urine porphyrins		\$71		
84120	26	Assay urine porphyrins		\$20		
84120	TC	Assay urine porphyrins		\$51		
84126		Assay feces porphyrins		\$131		
84126	26	Assay feces porphyrins		\$39		
84126	TC	Assay feces porphyrins		\$92		
84127		Porphyrins, feces		BR		
84127	26	Porphyrins, feces		BR		
84127	TC	Porphyrins, feces		BR		
84132		Assay serum potassium		\$20		
84132	26	Assay serum potassium		\$6		
84132	TC	Assay serum potassium		\$14		
84133		Assay urine potassium		\$20		
84133	26	Assay urine potassium		\$6		
84133	TC	Assay urine potassium		\$14		
84134		Prealbumin		BR		
84134	26	Prealbumin		BR		
84134	TC	Prealbumin		BR		
84135		Assay pregnanediol		\$108		
84135	26	Assay pregnanediol		\$37		
84135	TC	Assay pregnanediol		\$71		
84138		Assay pregnanetriol		\$106		
84138	26	Assay pregnanetriol		\$35		
84138	TC	Assay pregnanetriol		\$71		
84140		Assay for pregnenolone		\$77		
84140	26	Assay for pregnenolone		\$16		
84140	TC	Assay for pregnenolone		\$61		
84143		Assay/17-hydroxypregne		\$116		
84143	26	Assay/17-hydroxypregne		\$39		
84143	TC	Assay/17-hydroxypregne		\$77		
84144		Assay progesterone		\$71		
84144	26	Assay progesterone		\$14		
84144	TC	Assay progesterone		\$57		
84146		Assay for prolactin		\$100		
84146	26	Assay for prolactin		\$33		
84146	TC	Assay for prolactin		\$67		
84150		Assay of prostaglandin		\$127		
84150	26	Assay of prostaglandin		\$39		
84150	TC	Assay of prostaglandin		\$88		
84153		Assay of psa, total...		BR		
84153	26	Assay of psa, total...		BR		
84153	TC	Assay of psa, total...		BR		
84154		Assay of psa, free....		BR		
84155		Assay protein		\$22		
84155	26	Assay protein		\$8		
84155	TC	Assay protein		\$14		
84160		Assay serum protein		\$22		
84160	26	Assay serum protein		\$8		
84160	TC	Assay serum protein		\$14		

LABOR AND EMPLOYMENT

CPT Code	Mod	Description	Global Days	Maximum Allowance	Non-Facility Maximum	Facility Maximum
84165		Assay serum proteins		\$47		
84165	26	Assay serum proteins		\$16		
84165	TC	Assay serum proteins		\$31		
84181		Western blot test		\$40		
84181	26	Western blot test		BR		
84181	TC	Western blot test		BR		
84182		Protein, western blot		\$37		
84182	26	Protein, western blot		BR		
84182	TC	Protein, western blot		BR		
84202		Assay RBC protoporphyr		\$73		
84202	26	Assay RBC protoporphyr		\$24		
84202	TC	Assay RBC protoporphyr		\$49		
84203		Test RBC protoporphyr		\$30		
84203	26	Test RBC protoporphyr		\$10		
84203	TC	Test RBC protoporphyr		\$20		
84206		Assay of proinsulin		\$59		
84206	26	Assay of proinsulin		\$18		
84206	TC	Assay of proinsulin		\$41		
84207		Assay vitamin B-6		\$102		
84207	26	Assay vitamin B-6		\$31		
84207	TC	Assay vitamin B-6		\$71		
84210		Assay pyruvate		\$47		
84210	26	Assay pyruvate		\$18		
84210	TC	Assay pyruvate		\$29		
84220		Assay pyruvate kinase		\$49		
84220	26	Assay pyruvate kinase		\$16		
84220	TC	Assay pyruvate kinase		\$33		
84228		Assay quinine		\$59		
84228	26	Assay quinine		\$18		
84228	TC	Assay quinine		\$41		
84233		Assay estrogen		\$216		
84233	26	Assay estrogen		\$65		
84233	TC	Assay estrogen		\$151		
84234		Assay progesterone		\$216		
84234	26	Assay progesterone		\$65		
84234	TC	Assay progesterone		\$151		
84235		Assay endocrine hormon		\$212		
84235	26	Assay endocrine hormon		\$63		
84235	TC	Assay endocrine hormon		\$149		
84238		Assay non-endocrine re		\$179		
84238	26	Assay non-endocrine re		\$59		
84238	TC	Assay non-endocrine re		\$120		
84244		Assay of renin		\$96		
84244	26	Assay of renin		\$33		
84244	TC	Assay of renin		\$63		
84252		Assay vitamin B-2		\$87		
84252	26	Assay vitamin B-2		\$26		
84252	TC	Assay vitamin B-2		\$61		
84255		Assay selenium		\$110		
84255	26	Assay selenium		\$33		
84255	TC	Assay selenium		\$77		
84260		Assay serotonin		\$102		
84260	26	Assay serotonin		\$31		
84260	TC	Assay serotonin		\$71		
84270		Sex hormone globulin		BR		
84270	26	Sex hormone globulin		BR		
84270	TC	Sex hormone globulin		BR		
84275		Assay sialic acid		\$69		
84275	26	Assay sialic acid		\$20		
84275	TC	Assay sialic acid		\$49		
84285		Assay silica		\$112		
84285	26	Assay silica		\$33		
84285	TC	Assay silica		\$79		
84295		Assay serum sodium		\$18		
84295	26	Assay serum sodium		\$6		
84295	TC	Assay serum sodium		\$12		

Title 40, Part I

CPT Code	Mod	Description	Global Days	Maximum Allowance	Non-Facility Maximum	Facility Maximum
84300		Assay urine sodium		\$18		
84300	26	Assay urine sodium		\$6		
84300	TC	Assay urine sodium		\$12		
84305		Somatomedin		BR		
84305	26	Somatomedin		BR		
84305	TC	Somatomedin		BR		
84307		Somatostatin		BR		
84307	26	Somatostatin		BR		
84307	TC	Somatostatin		BR		
84311		Spectrophotometry		BR		
84311	26	Spectrophotometry		BR		
84311	TC	Spectrophotometry		BR		
84315		Body fluid specific gr		\$10		
84315	26	Body fluid specific gr		\$4		
84315	TC	Body fluid specific gr		\$6		
84375		Chromatogram assay, su		\$69		
84375	26	Chromatogram assay, su		\$20		
84375	TC	Chromatogram assay, su		\$49		
84376		Sugars, single, qual..		BR		
84377		Sugars, multiple, qual		BR		
84378		Sugars single quant..		BR		
84379		Sugars multiple quant		BR		
84392		Assay urine sulfate		BR		
84392	26	Assay urine sulfate		BR		
84392	TC	Assay urine sulfate		BR		
84402		Testosterone		BR		
84402	26	Testosterone		BR		
84402	TC	Testosterone		BR		
84403		Assay total testostero		\$123		
84403	26	Assay total testostero		\$37		
84403	TC	Assay total testostero		\$86		
84425		Assay vitamin B-1		\$102		
84425	26	Assay vitamin B-1		\$33		
84425	TC	Assay vitamin B-1		\$69		
84430		Assay thiocyanate		\$57		
84430	26	Assay thiocyanate		\$18		
84430	TC	Assay thiocyanate		\$39		
84432		Thyroglobulin		BR		
84432	26	Thyroglobulin		BR		
84432	TC	Thyroglobulin		BR		
84436		Assay, total thyroxine		\$26		
84436	26	Assay, total thyroxine		\$6		
84436	TC	Assay, total thyroxine		\$20		
84437		Assay neonatal thyroxi		\$24		
84437	26	Assay neonatal thyroxi		\$8		
84437	TC	Assay neonatal thyroxi		\$16		
84439		Assay, free thyroxine		\$30		
84439	26	Assay, free thyroxine		\$8		
84439	TC	Assay, free thyroxine		\$22		
84442		Thyroid activity (TBG)		\$49		
84442	26	Thyroid activity (TBG)		\$12		
84442	TC	Thyroid activity (TBG)		\$37		
84443		Assay thyroid stim hor		\$59		
84443	26	Assay thyroid stim hor		\$14		
84443	TC	Assay thyroid stim hor		\$45		
84445		Thyroid immunoglobulin		\$181		
84445	26	Thyroid immunoglobulin		\$55		
84445	TC	Thyroid immunoglobulin		\$126		
84446		Assay vitamin E		\$65		
84446	26	Assay vitamin E		\$20		
84446	TC	Assay vitamin E		\$45		
84449		Assay for transcortin		BR		
84449	26	Assay for transcortin		BR		
84449	TC	Assay for transcortin		BR		
84450		Transferase (AST) (SGO)		\$20		
84450	26	Transferase (AST) (SGO)		\$6		

LABOR AND EMPLOYMENT

CPT Code	Mod	Description	Global Days	Maximum Allowance	Non-Facility Maximum	Facility Maximum
84450	TC	Transferase (AST) (SGO		\$14		
84460		Alanine amino (ALT) (S		\$24		
84460	26	Alanine amino (ALT) (S		\$8		
84460	TC	Alanine amino (ALT) (S		\$16		
84466		Transferrin		BR		
84466	26	Transferrin		BR		
84466	TC	Transferrin		BR		
84478		Assay triglycerides		\$22		
84478	26	Assay triglycerides		\$6		
84478	TC	Assay triglycerides		\$16		
84479		Assay of thyroid (t3 or t4).		\$30		
84479	26	Assay of thyroid (t3 or t4).		\$11		
84479	TC	Assay of thyroid (t3 or t4).		\$19		
84480		Assay triiodothyronine		\$47		
84480	26	Assay triiodothyronine		\$16		
84480	TC	Assay triiodothyronine		\$31		
84481		Free assay (FT-3)		\$88		
84481	26	Free assay (FT-3)		\$29		
84481	TC	Free assay (FT-3)		\$59		
84482		T3 reverse		BR		
84482	26	T3 reverse		BR		
84482	TC	T3 reverse		BR		
84484		Assay of troponin, quant.		BR		
84485		Assay duodenal fluid t		\$28		
84485	26	Assay duodenal fluid t		\$8		
84485	TC	Assay duodenal fluid t		\$20		
84488		Test feces for trypsin		\$28		
84488	26	Test feces for trypsin		\$8		
84488	TC	Test feces for trypsin		\$20		
84490		Assay feces for trypsin		\$28		
84490	26	Assay feces for trypsin		\$8		
84490	TC	Assay feces for trypsin		\$20		
84510		Assay tyrosine		\$51		
84510	26	Assay tyrosine		\$16		
84510	TC	Assay tyrosine		\$35		
84512		Assay of troponin, qual.		BR		
84520		Assay urea nitrogen		\$22		
84520	26	Assay urea nitrogen		\$6		
84520	TC	Assay urea nitrogen		\$16		
84525		Urea nitrogen semi-qua		\$14		
84525	26	Urea nitrogen semi-qua		\$4		
84525	TC	Urea nitrogen semi-qua		\$10		
84540		Assay urine urea-N		\$24		
84540	26	Assay urine urea-N		\$8		
84540	TC	Assay urine urea-N		\$16		
84545		Urea-N clearance test		\$34		
84545	26	Urea-N clearance test		\$10		
84545	TC	Urea-N clearance test		\$24		
84550		Assay blood uric acid		\$22		
84550	26	Assay blood uric acid		\$8		
84550	TC	Assay blood uric acid		\$14		
84560		Assay urine uric acid		\$22		
84560	26	Assay urine uric acid		\$6		
84560	TC	Assay urine uric acid		\$16		
84577		Assay feces urobilinogen		\$63		
84577	26	Assay feces urobilinogen		\$20		
84577	TC	Assay feces urobilinogen		\$43		
84578		Test urine urobilinogen		\$14		
84578	26	Test urine urobilinogen		\$4		
84578	TC	Test urine urobilinogen		\$10		
84580		Assay urine urobilinogen		\$32		
84580	26	Assay urine urobilinogen		\$10		
84580	TC	Assay urine urobilinogen		\$22		
84583		Assay urine urobilinogen		\$20		
84583	26	Assay urine urobilinogen		\$6		
84583	TC	Assay urine urobilinogen		\$14		



Title 40, Part I

CPT Code	Mod	Description	Global Days	Maximum Allowance	Non-Facility Maximum	Facility Maximum
84585		Assay urine VMA		\$67		
84585	26	Assay urine VMA		\$20		
84585	TC	Assay urine VMA		\$47		
84586		VIP assay		BR		
84586	26	VIP assay		BR		
84586	TC	VIP assay		BR		
84588		Assay vasopressin		\$108		
84588	26	Assay vasopressin		\$37		
84588	TC	Assay vasopressin		\$71		
84590		Assay vitamin-A		\$61		
84590	26	Assay vitamin-A		\$20		
84590	TC	Assay vitamin-A		\$41		
84597		Assay vitamin-K		\$69		
84597	26	Assay vitamin-K		\$20		
84597	TC	Assay vitamin-K		\$49		
84600		Assay for volatiles		\$81		
84600	26	Assay for volatiles		\$24		
84600	TC	Assay for volatiles		\$57		
84620		Xylose tolerance test		\$55		
84620	26	Xylose tolerance test		\$16		
84620	TC	Xylose tolerance test		\$39		
84630		Assay zinc		\$51		
84630	26	Assay zinc		\$16		
84630	TC	Assay zinc		\$35		
84681		Assay C-peptide		\$98		
84681	26	Assay C-peptide		\$33		
84681	TC	Assay C-peptide		\$65		
84702		Chorionic gonadotropin		\$75		
84702	26	Chorionic gonadotropin		\$24		
84702	TC	Chorionic gonadotropin		\$51		
84703		Chorionic gonadotropin		\$71		
84703	26	Chorionic gonadotropin		\$22		
84703	TC	Chorionic gonadotropin		\$49		
84830		Ovulation tests		BR		
84830	26	Ovulation tests		BR		
84830	TC	Ovulation tests		BR		
84999		Clinical chemistry test		BR		
84999	26	Clinical chemistry test		BR		
84999	TC	Clinical chemistry test		BR		
85002		Bleeding time test		\$18		
85002	26	Bleeding time test		\$6		
85002	TC	Bleeding time test		\$12		
85007		Differential WBC count		\$12		
85007	26	Differential WBC count		\$4		
85007	TC	Differential WBC count		\$8		
85008		Nondifferential WBC co		BR		
85008	26	Nondifferential WBC co		BR		
85008	TC	Nondifferential WBC co		BR		
85009		Differential WBC count		\$16		
85009	26	Differential WBC count		\$6		
85009	TC	Differential WBC count		\$10		
85013		Hematocrit		BR		
85013	26	Hematocrit		BR		
85013	TC	Hematocrit		BR		
85014		Hematocrit		\$8		
85014	26	Hematocrit		\$2		
85014	TC	Hematocrit		\$6		
85018		Hemoglobin		\$10		
85018	26	Hemoglobin		\$4		
85018	TC	Hemoglobin		\$6		
85025		Automated hemogram		\$41		
85025	26	Automated hemogram		\$12		
85025	TC	Automated hemogram		\$29		
85027		Automated hemogram		\$36		
85027	26	Automated hemogram		\$12		
85027	TC	Automated hemogram		\$24		

LABOR AND EMPLOYMENT

CPT Code	Mod	Description	Global Days	Maximum Allowance	Non-Facility Maximum	Facility Maximum
85041		Red blood cell (RBC)		\$14		
85041	26	Red blood cell (RBC)		\$6		
85041	TC	Red blood cell (RBC)		\$8		
85044		Reticulocyte count		\$18		
85044	26	Reticulocyte count		\$6		
85044	TC	Reticulocyte count		\$12		
85045		Reticulocyte count		BR		
85045	26	Reticulocyte count		BR		
85045	TC	Reticulocyte count		BR		
85046		Reticyte/hgb concentrate.		BR		
85048		White blood cell (WBC)		\$14		
85048	26	White blood cell (WBC)		\$6		
85048	TC	White blood cell (WBC)		\$8		
85060		Blood smear interpreta		\$49		
85060	26	Blood smear interpreta		\$14		
85060	TC	Blood smear interpreta		\$35		
85097		Bone marrow interpreta		\$112		
85097	26	Bone marrow interpreta		\$112		
85097	TC	Bone marrow interpreta		\$0		
85130		Chromogenic substrate		BR		
85130	26	Chromogenic substrate		BR		
85130	TC	Chromogenic substrate		BR		
85170		Blood clot retraction		\$18		
85170	26	Blood clot retraction		\$6		
85170	TC	Blood clot retraction		\$12		
85175		Blood clot lysis time		\$18		
85175	26	Blood clot lysis time		\$6		
85175	TC	Blood clot lysis time		\$12		
85210		Blood clot factor II test		\$57		
85210	26	Blood clot factor II test		\$16		
85210	TC	Blood clot factor II test		\$41		
85220		Blood clot factor V test		\$88		
85220	26	Blood clot factor V test		\$29		
85220	TC	Blood clot factor V test		\$59		
85230		Blood clot factor VII		\$87		
85230	26	Blood clot factor VII		\$26		
85230	TC	Blood clot factor VII		\$61		
85240		Blood clot factor VIII		\$90		
85240	26	Blood clot factor VIII		\$29		
85240	TC	Blood clot factor VIII		\$61		
85244		Blood clot factor VIII		\$102		
85244	26	Blood clot factor VIII		\$35		
85244	TC	Blood clot factor VIII		\$67		
85245		Blood clot factor VIII		BR		
85245	26	Blood clot factor VIII		BR		
85245	TC	Blood clot factor VIII		BR		
85246		Blood clot factor VIII		BR		
85246	26	Blood clot factor VIII		BR		
85246	TC	Blood clot factor VIII		BR		
85247		Blood clot factor VIII		BR		
85247	26	Blood clot factor VIII		BR		
85247	TC	Blood clot factor VIII		BR		
85250		Blood clot factor IX test		\$91		
85250	26	Blood clot factor IX test		\$26		
85250	TC	Blood clot factor IX test		\$65		
85260		Blood clot factor X test		\$91		
85260	26	Blood clot factor X test		\$26		
85260	TC	Blood clot factor X test		\$65		
85270		Blood clot factor XI test		\$91		
85270	26	Blood clot factor XI test		\$26		
85270	TC	Blood clot factor XI test		\$65		
85280		Blood clot factor XII		\$91		
85280	26	Blood clot factor XII		\$26		
85280	TC	Blood clot factor XII		\$65		
85290		Blood clot factor XIII		\$83		
85290	26	Blood clot factor XIII		\$24		

Title 40, Part I

CPT Code	Mod	Description	Global Days	Maximum Allowance	Non-Facility Maximum	Facility Maximum
85290	TC	Blood clot factor XIII		\$59		
85291		Blood clot factor XIII		\$38		
85291	26	Blood clot factor XIII		\$12		
85291	TC	Blood clot factor XIII		\$26		
85292		Blood clot factor assay		\$96		
85292	26	Blood clot factor assay		\$33		
85292	TC	Blood clot factor assay		\$63		
85293		Blood clot factor assay		\$96		
85293	26	Blood clot factor assay		\$33		
85293	TC	Blood clot factor assay		\$63		
85300		Antithrombin III test		\$55		
85300	26	Antithrombin III test		\$18		
85300	TC	Antithrombin III test		\$37		
85301		Antithrombin III test		\$55		
85301	26	Antithrombin III test		\$18		
85301	TC	Antithrombin III test		\$37		
85302		Blood clot inhibitor assay		\$61		
85302	26	Blood clot inhibitor assay		\$20		
85302	TC	Blood clot inhibitor assay		\$41		
85303		Blood clot inhibitor test		BR		
85303	26	Blood clot inhibitor test		BR		
85303	TC	Blood clot inhibitor test		BR		
85305		Blood clot inhibitor assay		BR		
85305	26	Blood clot inhibitor assay		BR		
85305	TC	Blood clot inhibitor assay		BR		
85306		Blood clot inhibitor test		BR		
85306	26	Blood clot inhibitor test		BR		
85306	TC	Blood clot inhibitor test		BR		
85335		Factor inhibitor test		BR		
85335	26	Factor inhibitor test		BR		
85335	TC	Factor inhibitor test		BR		
85337		Thrombomodulin		BR		
85337	26	Thrombomodulin		BR		
85337	TC	Thrombomodulin		BR		
85345		Coagulation time		\$22		
85345	26	Coagulation time		\$6		
85345	TC	Coagulation time		\$16		
85347		Coagulation time		\$16		
85347	26	Coagulation time		\$4		
85347	TC	Coagulation time		\$12		
85348		Coagulation time		\$18		
85348	26	Coagulation time		\$6		
85348	TC	Coagulation time		\$12		
85360		Euglobulin lysis		\$30		
85360	26	Euglobulin lysis		\$8		
85360	TC	Euglobulin lysis		\$22		
85362		Fibrin degradation pro		\$34		
85362	26	Fibrin degradation pro		\$14		
85362	TC	Fibrin degradation pro		\$20		
85366		Fibrinogen test		BR		
85366	26	Fibrinogen test		BR		
85366	TC	Fibrinogen test		BR		
85370		Fibrinogen test		BR		
85370	26	Fibrinogen test		BR		
85370	TC	Fibrinogen test		BR		
85378		Fibrin degradation		BR		
85378	26	Fibrin degradation		BR		
85378	TC	Fibrin degradation		BR		
85379		Fibrin degradation		BR		
85379	26	Fibrin degradation		BR		
85379	TC	Fibrin degradation		BR		
85384		Fibrinogen		BR		
85384	26	Fibrinogen		BR		
85384	TC	Fibrinogen		BR		
85385		Fibrinogen		BR		
85385	26	Fibrinogen		BR		

LABOR AND EMPLOYMENT

CPT Code	Mod	Description	Global Days	Maximum Allowance	Non-Facility Maximum	Facility Maximum
85385	TC	Fibrinogen		BR		
85390		Fibrinolysins screen		\$18		
85390	26	Fibrinolysins screen		\$4		
85390	TC	Fibrinolysins screen		\$14		
85396		Clotting assay whole blood		\$40		
85400		Fibrinolytic plasmin		\$22		
85400	26	Fibrinolytic plasmin		\$6		
85400	TC	Fibrinolytic plasmin		\$16		
85410		Fibrinolytic antiplasm		\$22		
85410	26	Fibrinolytic antiplasm		\$6		
85410	TC	Fibrinolytic antiplasm		\$16		
85415		Fibrinolytic plasminog		BR		
85415	26	Fibrinolytic plasminog		BR		
85415	TC	Fibrinolytic plasminog		BR		
85420		Fibrinolytic plasminog		\$32		
85420	26	Fibrinolytic plasminog		\$8		
85420	TC	Fibrinolytic plasminog		\$24		
85421		Fibrinolytic plasminog		\$73		
85421	26	Fibrinolytic plasminog		\$22		
85421	TC	Fibrinolytic plasminog		\$51		
85441		Heinz bodies; direct		\$14		
85441	26	Heinz bodies; direct		\$4		
85441	TC	Heinz bodies; direct		\$10		
85445		Heinz bodies; induced		\$30		
85445	26	Heinz bodies; induced		\$10		
85445	TC	Heinz bodies; induced		\$20		
85460		Hemoglobin, fetal.....		\$32		
85460	26	Hemoglobin, fetal.....		\$9		
85460	TC	Hemoglobin, fetal.....		\$23		
85461		Hemoglobin, fetal		BR		
85475		Hemolysin		BR		
85475	26	Hemolysin		BR		
85475	TC	Hemolysin		BR		
85520		Heparin assay		\$43		
85520	26	Heparin assay		\$12		
85520	TC	Heparin assay		\$31		
85525		Heparin		BR		
85525	26	Heparin		BR		
85525	TC	Heparin		BR		
85530		Heparin-protamine tole		\$73		
85530	26	Heparin-protamine tole		\$22		
85530	TC	Heparin-protamine tole		\$51		
85540		Wbc alkaline phosphata		\$43		
85540	26	Wbc alkaline phosphata		\$12		
85540	TC	Wbc alkaline phosphata		\$31		
85547		RBC mechanical fragili		\$45		
85547	26	RBC mechanical fragili		\$12		
85547	TC	RBC mechanical fragili		\$33		
85549		Muramidase		\$86		
85549	26	Muramidase		\$29		
85549	TC	Muramidase		\$57		
85555		RBC osmotic fragility		\$32		
85555	26	RBC osmotic fragility		\$10		
85555	TC	RBC osmotic fragility		\$22		
85557		RBC osmotic fragility		\$63		
85557	26	RBC osmotic fragility		\$18		
85557	TC	RBC osmotic fragility		\$45		
85576		Blood platelet aggrega		\$41		
85576	26	Blood platelet aggrega		\$10		
85597		Platelet neutralizatio		BR		
85597	26	Platelet neutralizatio		BR		
85597	TC	Platelet neutralizatio		BR		
85610		Prothrombin time		\$12		
85610	26	Prothrombin time		\$4		
85610	TC	Prothrombin time		\$8		
85611		Prothrombin test		BR		

Title 40, Part I

CPT Code	Mod	Description	Global Days	Maximum Allowance	Non-Facility Maximum	Facility Maximum
85611	26	Prothrombin test		BR		
85611	TC	Prothrombin test		BR		
85612		Viper venom prothrombi		\$43		
85612	26	Viper venom prothrombi		\$12		
85612	TC	Viper venom prothrombi		\$31		
85613		Russell viper venom, d		BR		
85613	26	Russell viper venom, d		BR		
85613	TC	Russell viper venom, d		BR		
85635		Reptilase test		\$51		
85635	26	Reptilase test		\$16		
85635	TC	Reptilase test		\$35		
85651		Rbc sed rate, nonautomated		\$15		
85651	26	Rbc sed rate, nonautomated		\$3		
85651	TC	Rbc sed rate, nonautomated		\$10		
85652		Rbc sed rate, automated		BR		
85660		RBC sickle cell test		\$18		
85660	26	RBC sickle cell test		\$6		
85660	TC	RBC sickle cell test		\$12		
85670		Thrombin time, plasma		\$24		
85670	26	Thrombin time, plasma		\$6		
85670	TC	Thrombin time, plasma		\$18		
85675		Thrombin time, titer		\$24		
85675	26	Thrombin time, titer		\$8		
85675	TC	Thrombin time, titer		\$16		
85705		Thromboplastin inhibit		BR		
85705	26	Thromboplastin inhibit		BR		
85705	TC	Thromboplastin inhibit		BR		
85730		Thromboplastin time, p		\$20		
85730	26	Thromboplastin time, p		\$6		
85730	TC	Thromboplastin time, p		\$14		
85732		Thromboplastin time, p		\$32		
85732	26	Thromboplastin time, p		\$10		
85732	TC	Thromboplastin time, p		\$22		
85810		Blood viscosity examin		\$37		
85810	26	Blood viscosity examin		\$8		
85810	TC	Blood viscosity examin		\$29		
85999		Hematology procedure		BR		
85999	26	Hematology procedure		BR		
85999	TC	Hematology procedure		BR		
86000		Agglutinins; febrile		\$34		
86000	26	Agglutinins; febrile		\$12		
86000	TC	Agglutinins; febrile		\$22		
86003		Allergen specific IgE		BR		
86003	26	Allergen specific IgE		BR		
86003	TC	Allergen specific IgE		BR		
86005		Allergen specific IgE		BR		
86005	26	Allergen specific IgE		BR		
86005	TC	Allergen specific IgE		BR		
86021		WBC antibody identific		\$77		
86021	26	WBC antibody identific		\$22		
86021	TC	WBC antibody identific		\$55		
86022		Platelet antibodies		\$108		
86022	26	Platelet antibodies		\$35		
86022	TC	Platelet antibodies		\$73		
86023		Immunoglobulin assay		\$53		
86023	26	Immunoglobulin assay		\$18		
86023	TC	Immunoglobulin assay		\$35		
86038		Antinuclear antibodies		\$63		
86038	26	Antinuclear antibodies		\$20		
86038	TC	Antinuclear antibodies		\$43		
86039		Antinuclear antibodies		BR		
86039	26	Antinuclear antibodies		BR		
86039	TC	Antinuclear antibodies		BR		
86060		Antistreptolysin O titer		\$24		
86060	26	Antistreptolysin O titer		\$6		
86060	TC	Antistreptolysin O titer		\$18		

LABOR AND EMPLOYMENT

CPT Code	Mod	Description	Global Days	Maximum Allowance	Non-Facility Maximum	Facility Maximum
86063		Antistreptolysin O screen		\$41		
86063	26	Antistreptolysin O screen		\$12		
86063	TC	Antistreptolysin O screen		\$29		
86077		Physician blood bank s		\$169		
86077	26	Physician blood bank s		\$51		
86077	TC	Physician blood bank s		\$118		
86078		Physician blood bank s		\$169		
86078	26	Physician blood bank s		\$51		
86078	TC	Physician blood bank s		\$118		
86079		Physician blood bank s		\$147		
86079	26	Physician blood bank s		\$49		
86079	TC	Physician blood bank s		\$98		
86140		C-reactive protein		\$26		
86140	26	C-reactive protein		\$8		
86140	TC	C-reactive protein		\$18		
86147		Cardiolipin antibody		BR		
86147	26	Cardiolipin antibody		BR		
86147	TC	Cardiolipin antibody		BR		
86148		Phospholipid antibody		BR		
86155		Chemotaxis assay		\$51		
86155	26	Chemotaxis assay		\$16		
86155	TC	Chemotaxis assay		\$35		
86156		Cold agglutinin screen		BR		
86156	26	Cold agglutinin screen		BR		
86156	TC	Cold agglutinin screen		BR		
86157		Cold agglutinin, titer		BR		
86157	26	Cold agglutinin, titer		BR		
86157	TC	Cold agglutinin, titer		BR		
86160		Complement, antigen		BR		
86160	26	Complement, antigen		BR		
86160	TC	Complement, antigen		BR		
86161		Complement/function ac		BR		
86161	26	Complement/function ac		BR		
86161	TC	Complement/function ac		BR		
86162		Complement, total (CH5		\$102		
86162	26	Complement, total (CH5		\$35		
86162	TC	Complement, total (CH5		\$67		
86171		Complement fixation, each		\$49		
86171	26	Complement fixation, each		\$14		
86171	TC	Complement fixation, each		\$35		
86185		Counterimmunoelectroph		\$36		
86185	26	Counterimmunoelectroph		\$12		
86185	TC	Counterimmunoelectroph		\$24		
86215		Deoxyribonuclease, ant		\$67		
86215	26	Deoxyribonuclease, ant		\$22		
86215	TC	Deoxyribonuclease, ant		\$45		
86225		DNA antibody		\$67		
86225	26	DNA antibody		\$20		
86225	TC	DNA antibody		\$47		
86226		DNA antibody, single s		BR		
86226	26	DNA antibody, single s		BR		
86226	TC	DNA antibody, single s		BR		
86235		Nuclear antigen antibody		\$61		
86235	26	Nuclear antigen antibody		\$18		
86235	TC	Nuclear antigen antibody		\$43		
86243		Fc receptor		\$94		
86243	26	Fc receptor		\$29		
86243	TC	Fc receptor		\$65		
86255		Fluorescent antibody, screen		\$76		
86255	26	Fluorescent antibody, screen		\$41		
86255	TC	Fluorescent antibody,		\$35		
86256		Fluorescent antibody		\$49		
86256	26	Fluorescent antibody		\$16		
86256	TC	Fluorescent antibody		\$33		
86277		Growth hormone antibody		\$77		
86277	26	Growth hormone antibody		\$26		

Title 40, Part I

CPT Code	Mod	Description	Global Days	Maximum Allowance	Non-Facility Maximum	Facility Maximum
86277	TC	Growth hormone antibody		\$51		
86280		Hemagglutination inhib		\$28		
86280	26	Hemagglutination inhib		\$6		
86280	TC	Hemagglutination inhib		\$22		
86308		Heterophile antibodies		BR		
86308	26	Heterophile antibodies		BR		
86308	TC	Heterophile antibodies		BR		
86309		Heterophile antibodies		BR		
86309	26	Heterophile antibodies		BR		
86309	TC	Heterophile antibodies		BR		
86310		Heterophile antibodies		\$36		
86310	26	Heterophile antibodies		\$12		
86310	TC	Heterophile antibodies		\$24		
86316		Immunoassay, tumor ant		\$69		
86316	26	Immunoassay, tumor ant		\$20		
86316	TC	Immunoassay, tumor ant		\$49		
86317		Immunoassay,infectious agent		\$64		
86317	26	Immunoassay,infectious agent		\$20		
86317	TC	Immunoassay,infectious agent		\$44		
86318		Immunoassay,infectious agent		\$64		
86318	26	Immunoassay,infectious agent		\$26		
86318	TC	Immunoassay,infectious agent		\$38		
86320		Serum immunoelectropho		\$92		
86320	26	Serum immunoelectropho		\$37		
86320	TC	Serum immunoelectropho		\$55		
86325		Other immunoelectropho		\$92		
86325	26	Other immunoelectropho		\$31		
86325	TC	Other immunoelectropho		\$61		
86327		Immunoelectrophoresis		\$116		
86327	26	Immunoelectrophoresis		\$37		
86327	TC	Immunoelectrophoresis		\$79		
86328		IA Infectious Agt Antibody SARS-COV-2 COVID-19		\$90		
86329		Immunodiffusion		\$69		
86329	26	Immunodiffusion		\$22		
86329	TC	Immunodiffusion		\$47		
86331		Immunodiffusion ouchte		\$61		
86331	26	Immunodiffusion ouchte		\$18		
86331	TC	Immunodiffusion ouchte		\$43		
86332		Immune complex assay		\$102		
86332	26	Immune complex assay		\$35		
86332	TC	Immune complex assay		\$67		
86334		Immunofixation procedure		\$121		
86334	26	Immunofixation procedure		\$35		
86334	TC	Immunofixation procedure		\$86		
86335		Immunfix e-phorsis/urine/csf		\$40		
86337		Insulin antibodies		\$102		
86337	26	Insulin antibodies		\$35		
86337	TC	Insulin antibodies		\$67		
86340		Intrinsic factor antibody		\$73		
86340	26	Intrinsic factor antibody		\$24		
86340	TC	Intrinsic factor antibody		\$49		
86341		Islet cell antibody		BR		
86341	26	Islet cell antibody		BR		
86341	TC	Islet cell antibody		BR		
86343		Leukocyte histamine re		\$61		
86343	26	Leukocyte histamine re		\$20		
86343	TC	Leukocyte histamine re		\$41		
86344		Leukocyte phagocytosis		\$40		
86344	26	Leukocyte phagocytosis		\$14		
86344	TC	Leukocyte phagocytosis		\$26		
86353		Lymphocyte transformat		\$189		
86353	26	Lymphocyte transformat		\$57		
86353	TC	Lymphocyte transformat		\$132		
86359		T cells, total count		BR		
86359	26	T cells, total count		BR		

LABOR AND EMPLOYMENT

CPT Code	Mod	Description	Global Days	Maximum Allowance	Non-Facility Maximum	Facility Maximum
86359	TC	T cells, total count		BR		
86360		T cell, absolute count ratio		BR		
86360	26	T cell, absolute count ratio		BR		
86360	TC	T cell, absolute count ratio		BR		
86361		T cell, absolute count		BR		
86769		Anb Severe Aqt Respir Synd SARS-COV-2 COVID 19		\$84		
86376		Microsomal antibody		\$65		
86376	26	Microsomal antibody		\$20		
86376	TC	Microsomal antibody		\$45		
86378		Migration inhibitory f		\$86		
86378	26	Migration inhibitory f		\$29		
86378	TC	Migration inhibitory f		\$57		
86382		Neutralization test, viral		\$85		
86382	26	Neutralization test, viral		\$26		
86382	TC	Neutralization test, viral		\$59		
86384		Nitroblue tetrazolium		\$47		
86384	26	Nitroblue tetrazolium		\$16		
86384	TC	Nitroblue tetrazolium		\$31		
86403		Particle agglutination test		\$38		
86403	26	Particle agglutination test		\$8		
86403	TC	Particle agglutination test		\$30		
86406		Particle agglutination		BR		
86430		Rheumatoid factor test		\$24		
86430	26	Rheumatoid factor test		\$8		
86430	TC	Rheumatoid factor test		\$16		
86431		Rheumatoid factor, qua		\$32		
86431	26	Rheumatoid factor, qua		\$12		
86431	TC	Rheumatoid factor, qua		\$20		
86485		Skin test, candida		BR		
86485	26	Skin test, candida		BR		
86485	TC	Skin test, candida		BR		
86486		Skin test nos antigen		\$11		
86490		Coccidioidomycosis skin		\$32		
86490	26	Coccidioidomycosis skin		\$10		
86490	TC	Coccidioidomycosis skin		\$22		
86510		Histoplasmosis skin test		\$24		
86510	26	Histoplasmosis skin test		\$8		
86510	TC	Histoplasmosis skin test		\$16		
86580		TB intradermal test		\$24		
86580	26	TB intradermal test		\$8		
86580	TC	TB intradermal test		\$16		
86590		Streptokinase, antibody		\$34		
86590	26	Streptokinase, antibody		\$12		
86590	TC	Streptokinase, antibody		\$22		
86592		Blood serology, quality		\$16		
86592	26	Blood serology, quality		\$4		
86592	TC	Blood serology, quality		\$12		
86593		Blood serology, quantity		\$20		
86593	26	Blood serology, quantity		\$6		
86593	TC	Blood serology, quantity		\$14		
86602		Antinomyces antibody		BR		
86602	26	Antinomyces antibody		BR		
86602	TC	Antinomyces antibody		BR		
86603		Adenovirus, antibody		BR		
86603	26	Adenovirus, antibody		BR		
86603	TC	Adenovirus, antibody		BR		
86606		Aspergillus antibody		BR		
86606	26	Aspergillus antibody		BR		
86606	TC	Aspergillus antibody		BR		
86609		Bacterium, antibody		BR		
86609	26	Bacterium, antibody		BR		
86609	TC	Bacterium, antibody		BR		
86612		Blastomyces, antibody		BR		
86612	26	Blastomyces, antibody		BR		
86612	TC	Blastomyces, antibody		BR		



Title 40, Part I

CPT Code	Mod	Description	Global Days	Maximum Allowance	Non-Facility Maximum	Facility Maximum
86615		Bordetella antibody		BR		
86615	26	Bordetella antibody		BR		
86615	TC	Bordetella antibody		BR		
86617		Lyme disease antibody		BR		
86618		Lyme disease antibody		BR		
86618	26	Lyme disease antibody		BR		
86618	TC	Lyme disease antibody		BR		
86619		Borrelia antibody		BR		
86619	26	Borrelia antibody		BR		
86619	TC	Borrelia antibody		BR		
86622		Brucella, antibody		BR		
86622	26	Brucella, antibody		BR		
86622	TC	Brucella, antibody		BR		
86625		Campylobacter, antibody		BR		
86625	26	Campylobacter, antibody		BR		
86625	TC	Campylobacter, antibody		BR		
86628		Candida, antibody		BR		
86628	26	Candida, antibody		BR		
86628	TC	Candida, antibody		BR		
86631		Chlamydia, antibody		BR		
86631	26	Chlamydia, antibody		BR		
86631	TC	Chlamydia, antibody		BR		
86632		Chlamydia, IgM, antibody		BR		
86632	26	Chlamydia, IgM, antibody		BR		
86632	TC	Chlamydia, IgM, antibody		BR		
86635		Coccidioides, antibody		BR		
86635	26	Coccidioides, antibody		BR		
86635	TC	Coccidioides, antibody		BR		
86638		Q fever antibody		BR		
86638	26	Q fever antibody		BR		
86638	TC	Q fever antibody		BR		
86641		Cryptococcus antibody		BR		
86641	26	Cryptococcus antibody		BR		
86641	TC	Cryptococcus antibody		BR		
86644		CMV antibody		BR		
86644	26	CMV antibody		BR		
86644	TC	CMV antibody		BR		
86645		CMV antibody, IgM		BR		
86645	26	CMV antibody, IgM		BR		
86645	TC	CMV antibody, IgM		BR		
86648		Diphtheria antibody		BR		
86648	26	Diphtheria antibody		BR		
86648	TC	Diphtheria antibody		BR		
86651		Encephalitis antibody		BR		
86651	26	Encephalitis antibody		BR		
86651	TC	Encephalitis antibody		BR		
86652		Encephalitis antibody		BR		
86652	26	Encephalitis antibody		BR		
86652	TC	Encephalitis antibody		BR		
86653		Encephalitis, antibody		BR		
86653	26	Encephalitis, antibody		BR		
86653	TC	Encephalitis, antibody		BR		
86654		Encephalitis, antibody		BR		
86654	26	Encephalitis, antibody		BR		
86654	TC	Encephalitis, antibody		BR		
86658		Enterovirus, antibody		BR		
86658	26	Enterovirus, antibody		BR		
86658	TC	Enterovirus, antibody		BR		
86663		Epstein-barr antibody		BR		
86663	26	Epstein-barr antibody		BR		
86663	TC	Epstein-barr antibody		BR		
86664		Epstein-barr antibody		BR		
86664	26	Epstein-barr antibody		BR		
86664	TC	Epstein-barr antibody		BR		
86665		Epstein-barr, antibody		BR		
86665	26	Epstein-barr, antibody		BR		

LABOR AND EMPLOYMENT

CPT Code	Mod	Description	Global Days	Maximum Allowance	Non-Facility Maximum	Facility Maximum
86665	TC	Epstein-barr, antibody		BR		
86668		Francisella tularensis		BR		
86668	26	Francisella tularensis		BR		
86668	TC	Francisella tularensis		BR		
86671		Fungus, antibody		BR		
86671	26	Fungus, antibody		BR		
86671	TC	Fungus, antibody		BR		
86674		Giardia lamblia		BR		
86674	26	Giardia lamblia		BR		
86674	TC	Giardia lamblia		BR		
86677		Helicobacter pylori		BR		
86677	26	Helicobacter pylori		BR		
86677	TC	Helicobacter pylori		BR		
86682		Helminth, antibody		BR		
86682	26	Helminth, antibody		BR		
86682	TC	Helminth, antibody		BR		
86684		Hemophilus influenza		BR		
86684	26	Hemophilus influenza		BR		
86684	TC	Hemophilus influenza		BR		
86687		HTLV I		\$20		
86687	26	HTLV I		\$6		
86687	TC	HTLV I		\$14		
86688		HTLV-II		BR		
86688	26	HTLV-II		BR		
86688	TC	HTLV-II		BR		
86689		HTLV/HIV confirmatory		\$20		
86689	26	HTLV/HIV confirmatory		\$6		
86689	TC	HTLV/HIV confirmatory		\$14		
86692		Hepatitis, delta agent		BR		
86692	26	Hepatitis, delta agent		BR		
86692	TC	Hepatitis, delta agent		BR		
86694		Herpes simplex test		BR		
86694	26	Herpes simplex test		BR		
86694	TC	Herpes simplex test		BR		
86695		Herpes simplex test		BR		
86695	26	Herpes simplex test		BR		
86695	TC	Herpes simplex test		BR		
86698		Histoplasma		BR		
86698	26	Histoplasma		BR		
86698	TC	Histoplasma		BR		
86701		HIV-1		BR		
86701	26	HIV-1		BR		
86701	TC	HIV-1		BR		
86702		HIV-2		BR		
86702	26	HIV-2		BR		
86702	TC	HIV-2		BR		
86703		HIV-1/HIV-2, single assay		BR		
86703	26	HIV-1/HIV-2, single assay		BR		
86703	TC	HIV-1/HIV-2, single assay		BR		
86704		Hep b core antibody,		BR		
86705		Hep b core antibody, igm		BR		
86706		Hep b surface antibody		BR		
86707		Hep be antibody.....		BR		
86708		Hep a antibody, igg/ igm		BR		
86709		Hep a antibody, igm...		BR		
86710		Influenza virus antibody		BR		
86710	26	Influenza virus antibody		BR		
86710	TC	Influenza virus antibody		BR		
86713		Legionella		BR		
86713	26	Legionella		BR		
86713	TC	Legionella		BR		
86717		Leishmania		BR		
86717	26	Leishmania		BR		
86717	TC	Leishmania		BR		
86720		Leptospira		BR		
86720	26	Leptospira		BR		

Title 40, Part I

CPT Code	Mod	Description	Global Days	Maximum Allowance	Non-Facility Maximum	Facility Maximum
86720	TC	Leptospira		BR		
86723		Listeria monocytogenes		BR		
86723	26	Listeria monocytogenes		BR		
86723	TC	Listeria monocytogenes		BR		
86727		Lymph choriomeningitis		BR		
86727	26	Lymph choriomeningitis		BR		
86727	TC	Lymph choriomeningitis		BR		
86729		Lympho venereum		BR		
86729	26	Lympho venereum		BR		
86729	TC	Lympho venereum		BR		
86732		Mucormycosis		BR		
86732	26	Mucormycosis		BR		
86732	TC	Mucormycosis		BR		
86735		Mumps		\$24		
86735	26	Mumps		\$8		
86735	TC	Mumps		\$16		
86738		Mycoplasma		BR		
86738	26	Mycoplasma		BR		
86738	TC	Mycoplasma		BR		
86741		Neisseria meningitidis		BR		
86741	26	Neisseria meningitidis		BR		
86741	TC	Neisseria meningitidis		BR		
86744		Nocardia		BR		
86744	26	Nocardia		BR		
86744	TC	Nocardia		BR		
86747		Parvovirus		BR		
86747	26	Parvovirus		BR		
86747	TC	Parvovirus		BR		
86750		Malaria		BR		
86750	26	Malaria		BR		
86750	TC	Malaria		BR		
86753		Protozoa, not elsewhere		BR		
86753	26	Protozoa, not elsewhere		BR		
86753	TC	Protozoa, not elsewhere		BR		
86756		Respiratory virus		BR		
86756	26	Respiratory virus		BR		
86756	TC	Respiratory virus		BR		
86759		Rotavirus		BR		
86759	26	Rotavirus		BR		
86759	TC	Rotavirus		BR		
86762		Rubella		BR		
86762	26	Rubella		BR		
86762	TC	Rubella		BR		
86765		Rubeola		BR		
86765	26	Rubeola		BR		
86765	TC	Rubeola		BR		
86768		Salmonella		BR		
86768	26	Salmonella		BR		
86768	TC	Salmonella		BR		
86771		Shigella		BR		
86771	26	Shigella		BR		
86771	TC	Shigella		BR		
86774		Tetanus		BR		
86774	26	Tetanus		BR		
86774	TC	Tetanus		BR		
86777		Toxoplasma		BR		
86777	26	Toxoplasma		BR		
86777	TC	Toxoplasma		BR		
86778		Toxoplasma, IgM		BR		
86778	26	Toxoplasma, IgM		BR		
86778	TC	Toxoplasma, IgM		BR		
86784		Trichinella		BR		
86784	26	Trichinella		BR		
86784	TC	Trichinella		BR		
86787		Varicella-zoster		BR		
86787	26	Varicella-zoster		BR		

LABOR AND EMPLOYMENT

CPT Code	Mod	Description	Global Days	Maximum Allowance	Non-Facility Maximum	Facility Maximum
86787	TC	Varicella-zoster		BR		
86790		Virus, not specified		BR		
86790	26	Virus, not specified		BR		
86790	TC	Virus, not specified		BR		
86793		Yersinia		BR		
86793	26	Yersinia		BR		
86793	TC	Yersinia		BR		
86800		Thyroglobulin antibody		\$79		
86800	26	Thyroglobulin antibody		\$26		
86800	TC	Thyroglobulin antibody		\$53		
86803		Hepatitis c ab test...		BR		
86804		Hep c ab test, confirm		BR		
86805		Lymphocytotoxicity assay		\$179		
86805	26	Lymphocytotoxicity assay		\$61		
86805	TC	Lymphocytotoxicity assay		\$118		
86806		Lymphocytotoxicity assay		\$161		
86806	26	Lymphocytotoxicity assay		\$53		
86806	TC	Lymphocytotoxicity assay		\$108		
86807		Cytotoxic antibody scr		\$137		
86807	26	Cytotoxic antibody scr		\$41		
86807	TC	Cytotoxic antibody scr		\$96		
86808		Cytotoxic antibody scr		\$98		
86808	26	Cytotoxic antibody scr		\$29		
86808	TC	Cytotoxic antibody scr		\$69		
86812		HLA typing, A, B, or C		\$244		
86812	26	HLA typing, A, B, or C		\$73		
86812	TC	HLA typing, A, B, or C		\$171		
86813		HLA typing, A, B, or C		\$187		
86813	26	HLA typing, A, B, or C		\$57		
86813	TC	HLA typing, A, B, or C		\$130		
86816		HLA typing, DR/DQ		\$119		
86816	26	HLA typing, DR/DQ		\$35		
86816	TC	HLA typing, DR/DQ		\$84		
86817		HLA typing, DR/DQ		\$246		
86817	26	HLA typing, DR/DQ		\$73		
86817	TC	HLA typing, DR/DQ		\$173		
86821		Lymphocyte culture, mi		\$226		
86821	26	Lymphocyte culture, mi		\$67		
86821	TC	Lymphocyte culture, mi		\$159		
86822		Lymphocyte culture, pr		\$177		
86822	26	Lymphocyte culture, pr		\$59		
86822	TC	Lymphocyte culture, pr		\$118		
86849		Immunology procedure		BR		
86849	26	Immunology procedure		BR		
86849	TC	Immunology procedure		BR		
86850		RBC antibody screen		\$22		
86850	26	RBC antibody screen		\$8		
86850	TC	RBC antibody screen		\$14		
86860		RBC antibody elution		\$84		
86860	26	RBC antibody elution		\$29		
86860	TC	RBC antibody elution		\$55		
86870		RBC antibody identific		BR		
86870	26	RBC antibody identific		BR		
86870	TC	RBC antibody identific		BR		
86880		Coombs test		\$24		
86880	26	Coombs test		\$8		
86880	TC	Coombs test		\$16		
86885		Coombs test		BR		
86885	26	Coombs test		BR		
86885	TC	Coombs test		BR		
86886		Coombs test		\$26		
86886	26	Coombs test		\$8		
86886	TC	Coombs test		\$18		
86890		Autologous blood proce		BR		
86890	26	Autologous blood proce		BR		
86890	TC	Autologous blood proce		BR		

Title 40, Part I

CPT Code	Mod	Description	Global Days	Maximum Allowance	Non-Facility Maximum	Facility Maximum
86891		Autologous blood, op s		\$169		
86891	26	Autologous blood, op s		\$51		
86891	TC	Autologous blood, op s		\$118		
86900		Blood typing, ABO		\$20		
86900	26	Blood typing, ABO		\$6		
86900	TC	Blood typing, ABO		\$14		
86901		Blood typing, Rh (D)		\$22		
86901	26	Blood typing, Rh (D)		\$8		
86901	TC	Blood typing, Rh (D)		\$14		
86904		Blood typing, patient		\$36		
86904	26	Blood typing, patient		\$12		
86904	TC	Blood typing, patient		\$24		
86905		Blood typing, RBC anti		\$16		
86905	26	Blood typing, RBC anti		\$4		
86905	TC	Blood typing, RBC anti		\$12		
86906		Blood typing, Rh pheno		BR		
86906	26	Blood typing, Rh pheno		BR		
86906	TC	Blood typing, Rh pheno		BR		
86910		Blood typing, paternity test		\$155		
86910	26	Blood typing, paternity test		\$47		
86910	TC	Blood typing, paternity test		\$108		
86911		Blood typing, antigen		BR		
86911	26	Blood typing, antigen		BR		
86911	TC	Blood typing, antigen		BR		
86920		Compatibility test		\$39		
86920	26	Compatibility test		\$8		
86920	TC	Compatibility test		\$31		
86921		Compatibility test		\$45		
86921	26	Compatibility test		\$14		
86921	TC	Compatibility test		\$31		
86922		Compatibility test		\$45		
86922	26	Compatibility test		\$14		
86922	TC	Compatibility test		\$31		
86927		Plasma, fresh frozen		BR		
86927	26	Plasma, fresh frozen		BR		
86927	TC	Plasma, fresh frozen		BR		
86930		Frozen blood prep		\$286		
86930	26	Frozen blood prep		\$86		
86930	TC	Frozen blood prep		\$200		
86931		Frozen blood thaw		\$286		
86931	26	Frozen blood thaw		\$86		
86931	TC	Frozen blood thaw		\$200		
86932		Frozen blood, freeze/t		\$296		
86932	26	Frozen blood, freeze/t		\$90		
86932	TC	Frozen blood, freeze/t		\$206		
86940		Hemolysins/ agglutinins, auto		\$34		
86940	26	Hemolysins/ agglutinins, auto		\$10		
86940	TC	Hemolysins/ agglutinins, auto		\$24		
86941		Hemolysins/agglutinins		\$57		
86941	26	Hemolysins/agglutinins		\$16		
86941	TC	Hemolysins/agglutinins		\$41		
86945		Blood product/irradiation		\$65		
86945	26	Blood product/irradiation		\$20		
86945	TC	Blood product/irradiation		\$45		
86950		Leukocyte transfusion		\$183		
86950	26	Leukocyte transfusion		\$55		
86950	TC	Leukocyte transfusion		\$128		
86965		Pooling blood platelet		\$49		
86965	26	Pooling blood platelet		\$14		
86965	TC	Pooling blood platelet		\$35		
86970		RBC pretreatment		\$77		
86970	26	RBC pretreatment		\$22		
86970	TC	RBC pretreatment		\$55		
86971		RBC pretreatment		\$39		
86971	26	RBC pretreatment		\$10		
86971	TC	RBC pretreatment		\$29		

LABOR AND EMPLOYMENT

CPT Code	Mod	Description	Global Days	Maximum Allowance	Non-Facility Maximum	Facility Maximum
86972		RBC pretreatment		\$38		
86972	26	RBC pretreatment		\$12		
86972	TC	RBC pretreatment		\$26		
86975		RBC pretreatment, serum		\$100		
86975	26	RBC pretreatment, serum		\$31		
86975	TC	RBC pretreatment, serum		\$69		
86976		RBC pretreatment, serum		\$100		
86976	26	RBC pretreatment, serum		\$31		
86976	TC	RBC pretreatment, serum		\$69		
86977		RBC pretreatment, serum		\$100		
86977	26	RBC pretreatment, serum		\$31		
86977	TC	RBC pretreatment, serum		\$69		
86978		RBC pretreatment, serum		\$121		
86978	26	RBC pretreatment, serum		\$37		
86978	TC	RBC pretreatment, serum		\$84		
86985		Split blood or product		BR		
86985	26	Split blood or product		BR		
86985	TC	Split blood or product		BR		
86999		Transfusion procedure		BR		
86999	26	Transfusion procedure		BR		
86999	TC	Transfusion procedure		BR		
87001		Small animal inoculation		\$65		
87001	26	Small animal inoculation		\$20		
87001	TC	Small animal inoculation		\$45		
87003		Small animal inoculation		\$75		
87003	26	Small animal inoculation		\$24		
87003	TC	Small animal inoculation		\$51		
87015		Specimen concentration		\$30		
87015	26	Specimen concentration		\$10		
87015	TC	Specimen concentration		\$20		
87040		Blood culture for bact		\$34		
87040	26	Blood culture for bact		\$12		
87040	TC	Blood culture for bact		\$22		
87045		Stool culture for bact		\$43		
87045	26	Stool culture for bact		\$14		
87045	TC	Stool culture for bact		\$29		
87070		Culture specimen, bact		\$26		
87070	26	Culture specimen, bact		\$8		
87070	TC	Culture specimen, bact		\$18		
87075		Culture specimen, bact		\$34		
87075	26	Culture specimen, bact		\$12		
87075	TC	Culture specimen, bact		\$22		
87076		Bacteria identification		\$47		
87076	26	Bacteria identification		\$16		
87076	TC	Bacteria identification		\$31		
87081		Bacteria culture screen		\$22		
87081	26	Bacteria culture screen		\$6		
87081	TC	Bacteria culture screen		\$16		
87084		Culture of specimen by		\$45		
87084	26	Culture of specimen by		\$14		
87084	TC	Culture of specimen by		\$31		
87086		Urine culture, colony		\$26		
87086	26	Urine culture, colony		\$6		
87086	TC	Urine culture, colony		\$20		
87088		Urine bacteria culture		\$34		
87088	26	Urine bacteria culture		\$12		
87088	TC	Urine bacteria culture		\$22		
87101		Skin fungus culture		\$38		
87101	26	Skin fungus culture		\$12		
87101	TC	Skin fungus culture		\$26		
87102		Fungus isolation cultu		\$38		
87102	26	Fungus isolation cultu		\$12		
87102	TC	Fungus isolation cultu		\$26		
87103		Blood fungus culture		\$59		
87103	26	Blood fungus culture		\$20		
87103	TC	Blood fungus culture		\$39		

Title 40, Part I

CPT Code	Mod	Description	Global Days	Maximum Allowance	Non-Facility Maximum	Facility Maximum
87106		Fungus identification		\$49		
87106	26	Fungus identification		\$14		
87106	TC	Fungus identification		\$35		
87109		Mycoplasma culture		\$51		
87109	26	Mycoplasma culture		\$16		
87109	TC	Mycoplasma culture		\$35		
87110		Culture, chlamydia		\$61		
87110	26	Culture, chlamydia		\$18		
87110	TC	Culture, chlamydia		\$43		
87116		Mycobacteria culture		\$49		
87116	26	Mycobacteria culture		\$14		
87116	TC	Mycobacteria culture		\$35		
87118		Mycobacteria identific		\$49		
87118	26	Mycobacteria identific		\$14		
87118	TC	Mycobacteria identific		\$35		
87140		Culture typing, fluore		\$47		
87140	26	Culture typing, fluore		\$14		
87140	TC	Culture typing, fluore		\$33		
87143		Culture typing, GLC me		\$63		
87143	26	Culture typing, GLC me		\$20		
87143	TC	Culture typing, GLC me		\$43		
87147		Culture typing, serolo		\$51		
87147	26	Culture typing, serolo		\$16		
87147	TC	Culture typing, serolo		\$35		
87158		Culture typing, added		\$18		
87158	26	Culture typing, added		\$4		
87158	TC	Culture typing, added		\$14		
87163		Special microbiology c		\$57		
87163	26	Special microbiology c		\$18		
87163	TC	Special microbiology c		\$39		
87164		Dark field examination		\$47		
87164	26	Dark field examination		\$16		
87164	TC	Dark field examination		\$31		
87166		Dark field examination		\$47		
87166	26	Dark field examination		\$14		
87166	TC	Dark field examination		\$33		
87176		Endotoxin, bacterial		\$30		
87176	26	Endotoxin, bacterial		\$10		
87176	TC	Endotoxin, bacterial		\$20		
87177		Ova and parasites smear		\$34		
87177	26	Ova and parasites smear		\$12		
87177	TC	Ova and parasites smear		\$22		
87181		Antibiotic sensitivity		\$24		
87181	26	Antibiotic sensitivity		\$8		
87181	TC	Antibiotic sensitivity		\$16		
87184		Antibiotic sensitivity, each		\$27		
87184	26	Antibiotic sensitivity, each		\$7		
87184	TC	Antibiotic sensitivity, each		\$20		
87186		Antibiotic sensitivity		\$30		
87186	26	Antibiotic sensitivity		\$8		
87186	TC	Antibiotic sensitivity		\$22		
87187		Antibiotic sensitivity		\$39		
87187	26	Antibiotic sensitivity		\$6		
87187	TC	Antibiotic sensitivity		\$33		
87188		Antibiotic sensitivity		\$34		
87188	26	Antibiotic sensitivity		\$10		
87188	TC	Antibiotic sensitivity		\$24		
87190		TB antibiotic sensitivity		\$14		
87190	26	TB antibiotic sensitivity		\$4		
87190	TC	TB antibiotic sensitivity		\$10		
87197		Bactericidal level, serum		\$55		
87197	26	Bactericidal level, serum		\$18		
87197	TC	Bactericidal level, serum		\$37		
87205		Smear, stain & interpret		\$20		
87205	26	Smear, stain & interpret		\$6		
87205	TC	Smear, stain & interpret		\$14		

LABOR AND EMPLOYMENT

CPT Code	Mod	Description	Global Days	Maximum Allowance	Non-Facility Maximum	Facility Maximum
87206		Smear, stain & interpret		\$28		
87206	26	Smear, stain & interpret		\$6		
87206	TC	Smear, stain & interpret		\$22		
87207		Smear, stain & interpret		\$18		
87207	26	Smear, stain & interpret		\$6		
87207	TC	Smear, stain & interpret		\$12		
87210		Smear, stain & interpret		\$16		
87210	26	Smear, stain & interpret		\$4		
87210	TC	Smear, stain & interpret		\$12		
87220		Tissue exam for fungi		\$22		
87220	26	Tissue exam for fungi		\$8		
87220	TC	Tissue exam for fungi		\$14		
87230		Assay, toxin or antitoxin		\$65		
87230	26	Assay, toxin or antitoxin		\$20		
87230	TC	Assay, toxin or antitoxin		\$45		
87250		Virus inoculation for test		\$61		
87250	26	Virus inoculation for test		\$24		
87250	TC	Virus inoculation for test		\$37		
87252		Virus inoculation for test		\$83		
87252	26	Virus inoculation for test		\$26		
87252	TC	Virus inoculation for test		\$57		
87253		Virus inoculation for test		\$61		
87253	26	Virus inoculation for test		\$18		
87253	TC	Virus inoculation for test		\$43		
87260		Adenovirus ag, dfa....		BR		
87265		Pertussis ag, dfa....		BR		
87270		Chylmd trach ag, dfa..		BR		
87272		Cryptosporidium ag, dfa		BR		
87274		Herpes simplex ag, dfa		BR		
87276		Influenza ag, dfa....		BR		
87278		Legion pneumo ag, dfa.		BR		
87280		Resp syncytial ag, dfa		BR		
87285		Trepon pallidum ag, dfa.		BR		
87290		Varicella ag, dfa....		BR		
87299		Ag detection nos, dfa.		BR		
87301		Adenovirus ag, eia....		BR		
87320		Chylmd trach ag, eia..		BR		
87324		Clostridium ag, eia...		BR		
87328		Cryptospor ag, eia		BR		
87332		Cytomegalovirus ag, eia		BR		
87335		E coli 0157 ag, eia...		BR		
87338		Hpylori, stool, eia...		BR		
87340		Hepatitis b surface ag, eia		BR		
87350		Hepatitis be ag, eia..		BR		
87380		Hepatitis delta ag, eia		BR		
87385		Histoplasma capsul ag, eia		BR		
87390		Hiv-1 ag, eia.....		BR		
87391		Hiv-2 ag, eia.....		BR		
87420		Resp syncytial ag, eia		BR		
87425		Rotavirus ag, eia.....		BR		
87430		Strep a ag, eia.....		BR		
87449		Ag detect nos, eia, mult		BR		
87450		Ag detect nos, eia, single		BR		
87470		Bartonella, dna, dir probe		BR		
87471		Bartonella, dna, amp probe		BR		
87472		Bartonella, dna, quant		BR		
87475		Lyme dis, dna, dir probe		BR		
87476		Lyme dis, dna, amp probe		BR		
87477		Lyme dis, dna, quant..		BR		
87480		Candida, dna, dir probe		BR		
87481		Candida, dna, amp probe		BR		
87482		Candida, dna, quant...		BR		
87485		Chylmd pneum, dna, dir probe		BR		
87486		Chylmd pneum, dna, amp probe		BR		
87487		Chylmd pneum, dna, quant		BR		
87490		Chylmd trach, dna, dir probe		BR		



Title 40, Part I

CPT Code	Mod	Description	Global Days	Maximum Allowance	Non-Facility Maximum	Facility Maximum
87491		Chylmd trach, dna, amp v		BR		
87492		Chylmd trach, dna, quant		BR		
87495		Cytomeg, dna, dir probe		BR		
87496		Cytomeg, dna, amp probe		BR		
87497		Cytomeg, dna, quant...		BR		
87510		Gardner vag, dna, dir probe		BR		
87511		Gardner vag, dna, amp probe		BR		
87512		Gardner vag, dna, quant		BR		
87515		Hepatitis b, dna, dir probe		BR		
87516		Hepatitis b , dna, amp probe		BR		
87517		Hepatitis b , dna, quant		BR		
87520		Hepatitis c , rna, dir probe		BR		
87521		Hepatitis c , rna, amp probe		BR		
87522		Hepatitis c, rna, quant		BR		
87525		Hepatitis g , dna, dir probe		BR		
87526		Hepatitis g, dna, amp probe		BR		
87527		Hepatitis g, dna, quant		BR		
87528		Hsv, dna, dir probe...		BR		
87529		Hsv, dna, amp probe...		BR		
87530		Hsv, dna, quant.....		BR		
87531		Hhv-6, dna, dir probe		BR		
87532		Hhv-6, dna, amp probe		BR		
87533		Hhv-6, dna, quant.....		BR		
87534		Hiv-1, dna, dir probe		BR		
87535		Hiv-1, dna, amp probe		BR		
87536		Hiv-1, dna, quant.....		BR		
87537		Hiv-2, dna, dir probe		BR		
87538		Hiv-2, dna, amp probe		BR		
87539		Hiv-2, dna, quant.....		BR		
87540		Legion pneumo, dna, dir probe		BR		
87541		Legion pneumo, dna, amp probe		BR		
87542		Legion pneumo, dna, quant		BR		
87550		Mycobacteria, dna, dir probe		BR		
87551		Mycobacteria, dna, amp probe		BR		
87552		Mycobacteria, dna, quant		BR		
87555		M.tuberculo, dna, dir probe		BR		
87556		M.tuberculo, dna, amp probe		BR		
87557		M.tuberculo, dna, quant.		BR		
87560		M.avium-intra, dna, dir probe		BR		
87561		M.avium-intra, dna, amp		BR		
87562		M.avium-intra, dna, quant		BR		
87580		M.pneumon, dna, dir probe		BR		
87581		M.pneumon, dna, amp probe		BR		
87582		M.pneumon, dna, quant		BR		
87590		N.gonorrhoeae, dna, dir probe		BR		
87591		N.gonorrhoeae, dna, amp probe		BR		
87592		N.gonorrhoeae, dna, quant		BR		
87620		Hpv, dna, dir probe...		BR		
87621		Hpv, dna, amp probe...		BR		
87622		Hpv, dna, quant.....		BR		
87635		IADNA SARS-COV-2 COVID-19 Amplified Probe TQ		\$103		
87650		Strep a, dna, dir probe		BR		
87651		Strep a, dna, amp probe		BR		
87652		Strep a, dna, quant...		BR		
87797		Detect agent nos, dna, dir		BR		
87798		Detect agent nos, dna, amp		BR		
87799		Detect agent nos, dna, quant		BR		
87810		Chylmd trach assay w/optic		BR		
87850		N. gonorrhoeae assay w		BR		
87880		Strep a assay w/optic		BR		
87899		Agent nos assay w/optic		BR		
87999		Microbiology procedure		BR		
87999	26	Microbiology procedure		BR		
87999	TC	Microbiology procedure		BR		
88000		Autopsy (necropsy), gross		\$815		

LABOR AND EMPLOYMENT

CPT Code	Mod	Description	Global Days	Maximum Allowance	Non-Facility Maximum	Facility Maximum
88000	26	Autopsy (necropsy), gross		\$815		
88000	TC	Autopsy (necropsy), gross		\$0		
88005		Autopsy (necropsy), gross		\$917		
88005	26	Autopsy (necropsy), gross		\$917		
88005	TC	Autopsy (necropsy), gross		\$0		
88007		Autopsy (necropsy), gross		\$1,019		
88007	26	Autopsy (necropsy), gross		\$1,019		
88007	TC	Autopsy (necropsy), gross		\$0		
88012		Autopsy (necropsy), gross		\$856		
88012	26	Autopsy (necropsy), gross		\$856		
88012	TC	Autopsy (necropsy), gross		\$0		
88014		Autopsy (necropsy), gross		\$856		
88014	26	Autopsy (necropsy), gross		\$856		
88014	TC	Autopsy (necropsy), gross		\$0		
88016		Autopsy (necropsy), gross		\$815		
88016	26	Autopsy (necropsy), gross		\$815		
88016	TC	Autopsy (necropsy), gross		\$0		
88020		Autopsy (necropsy), co		\$1,019		
88020	26	Autopsy (necropsy), co		\$1,019		
88020	TC	Autopsy (necropsy), co		\$0		
88025		Autopsy (necropsy), co		\$1,120		
88025	26	Autopsy (necropsy), co		\$1,120		
88025	TC	Autopsy (necropsy), co		\$0		
88027		Autopsy (necropsy), co		\$1,222		
88027	26	Autopsy (necropsy), co		\$1,222		
88027	TC	Autopsy (necropsy), co		\$0		
88028		Autopsy (necropsy), co		\$1,059		
88028	26	Autopsy (necropsy), co		\$1,059		
88028	TC	Autopsy (necropsy), co		\$0		
88029		Autopsy (necropsy), co		\$1,059		
88029	26	Autopsy (necropsy), co		\$1,059		
88029	TC	Autopsy (necropsy), co		\$0		
88036		Limited autopsy		\$876		
88036	26	Limited autopsy		\$876		
88036	TC	Limited autopsy		\$0		
88037		Limited autopsy		\$713		
88037	26	Limited autopsy		\$713		
88037	TC	Limited autopsy		\$0		
88040		Forensic autopsy (necr		\$2,648		
88040	26	Forensic autopsy (necr		\$2,648		
88040	TC	Forensic autopsy (necr		\$0		
88045		Coroner's autopsy (nec		BR		
88045	26	Coroner's autopsy (nec		BR		
88045	TC	Coroner's autopsy (nec		BR		
88099		Necropsy (autopsy) pro		BR		
88099	26	Necropsy (autopsy) pro		BR		
88099	TC	Necropsy (autopsy) pro		BR		
88104		Cytopathology, fluids		\$73		
88104	26	Cytopathology, fluids		\$57		
88104	TC	Cytopathology, fluids		\$16		
88106		Cytopathology, fluids		\$102		
88106	26	Cytopathology, fluids		\$31		
88106	TC	Cytopathology, fluids		\$71		
88108		Cytopath, concentrate tech		\$77		
88108	26	Cytopath, concentrate tech		\$59		
88108	TC	Cytopath, concentrate tech		\$19		
88112	26	Cytopath cell enhance tech		\$117		
88112	TC	Cytopath cell enhance tech		\$91		
88112		Cytopath cell enhance tech		\$208		
88120	26	Cytp urine 3-5 probes ea spec		\$108		
88120	TC	Cytp urine 3-5 probes ea spec		\$865		
88120		Cytp urine 3-5 probes ea spec		\$973		
88121	26	Cytp urine 3-5 probes cmpr		\$96		
88121	TC	Cytp urine 3-5 probes cmpr		\$742		
88121		Cytp urine 3-5 probes cmpr		\$838		
88125		Forensic cytopathology		\$129		

Title 40, Part I

CPT Code	Mod	Description	Global Days	Maximum Allowance	Non-Facility Maximum	Facility Maximum
88125	26	Forensic cytopathology		\$39		
88125	TC	Forensic cytopathology		\$90		
88130		Sex chromatin identifi		\$49		
88130	26	Sex chromatin identifi		\$14		
88130	TC	Sex chromatin identifi		\$35		
88140		Sex chromatin identifi		\$34		
88140	26	Sex chromatin identifi		\$10		
88140	TC	Sex chromatin identifi		\$24		
88141		Cytopath, c/v, interpret		\$70		
88142		Cytopath, c/v, thin layer		BR		
88143		Cytopath c/v thin layer redo		BR		
88147		Cytopath, c/v, automated		BR		
88148		Cytopath, c/v, auto rescreen		BR		
88150		Cytopath, c/v, manual		\$23		
88150	26	Cytopath, c/v, manual		\$8		
88150	TC	Cytopath, c/v, manual		\$15		
88152		Cytopath, c/v, auto redo		BR		
88153		Cytopath, c/v, redo...		BR		
88154		Cytopath, c/v, select		BR		
88155		Cytopath, c/v, index add-on		\$25		
88155	26	Cytopath, c/v, index add-on		\$7		
88155	TC	Cytopath, c/v, index add-on		\$18		
88160		Cytopath smear, other		\$73		
88160	26	Cytopath smear, other		\$22		
88160	TC	Cytopath smear, other		\$51		
88161		Cytopath smear, other		\$102		
88161	26	Cytopath smear, other		\$31		
88161	TC	Cytopath smear, other		\$71		
88162		Cytopath smear, other		\$143		
88162	26	Cytopath smear, other		\$43		
88162	TC	Cytopath smear, other		\$100		
88164		Cytopath tbs, c/v, manual		BR		
88165		Cytopath tbs, c/v, redo		BR		
88166		Cytopath tbs, c/v, auto redo		BR		
88167		Cytopath tbs, c/v, select		BR		
88172		Evaluation of smear		\$128		
88172	26	Evaluation of smear		\$102		
88172	TC	Evaluation of smear		\$26		
88173		Interpretation of smear		\$128		
88173	26	Interpretation of smear		\$128		
88173	TC	Interpretation of smear		\$0		
88177	26	Cytp fna eval ea addl		\$43		
88177	TC	Cytp fna eval ea addl		\$14		
88177		Cytp fna eval ea addl		\$57		
88182		Cell marker study		\$163		
88182	26	Cell marker study		\$61		
88182	TC	Cell marker study		\$102		
88184		Flowcytometry/ tc 1 marker		\$165		
88185		Flowcytometry/tc add-on		\$100		
88187		Flowcytometry/read 2-8		\$139		
88188		Flowcytometry/read 9-15		\$176		
88189		Flowcytometry/read 16 & >		\$213		
88199		Cytopathology procedure		BR		
88199	26	Cytopathology procedure		BR		
88199	TC	Cytopathology procedure		BR		
88230		Tissue culture, lymphocyte		\$482		
88230	26	Tissue culture, lymphocyte		\$143		
88230	TC	Tissue culture, lymphocyte		\$339		
88233		Tissue culture, skin/b		\$448		
88233	26	Tissue culture, skin/b		\$134		
88233	TC	Tissue culture, skin/b		\$314		
88235		Tissue culture, placenta		\$469		
88235	26	Tissue culture, placenta		\$141		
88235	TC	Tissue culture, placenra		\$328		
88237		Tissue culture, bone		\$526		
88237	26	Tissue culture, bone		\$158		

LABOR AND EMPLOYMENT

CPT Code	Mod	Description	Global Days	Maximum Allowance	Non-Facility Maximum	Facility Maximum
88237	TC	Tissue culture, bone		\$368		
88239		Tissue culture, tumor		\$613		
88239	26	Tissue culture, tumor		\$184		
88239	TC	Tissue culture, tumor		\$429		
88240		Cell cryopreserve/ storage		BR		
88241		Frozen cell preparation		BR		
88245		Chromosome analysis, 20-		\$617		
88245	26	Chromosome analysis, 20-		\$184		
88245	TC	Chromosome analysis, 20-		\$433		
88248		Chromosome analysis, 50-		\$721		
88248	26	Chromosome analysis, 50-		\$217		
88248	TC	Chromosome analysis, 50-		\$504		
88249		Chromosome analysis, 100		BR		
88261		Chromosome analysis, 5		\$736		
88261	26	Chromosome analysis, 5		\$221		
88261	TC	Chromosome analysis, 5		\$515		
88262		Chromosome analysis, 1		\$580		
88262	26	Chromosome analysis, 1		\$175		
88262	TC	Chromosome analysis, 1		\$405		
88263		Chromosome analysis, 4		\$489		
88263	26	Chromosome analysis, 4		\$147		
88263	TC	Chromosome analysis, 4		\$342		
88264		Chromosome analysis, 20-25		BR		
88267		Chromosome analysis:pl		\$890		
88267	26	Chromosome analysis:pl		\$267		
88267	TC	Chromosome analysis:pl		\$623		
88269		Chromosome analysis:am		\$489		
88269	26	Chromosome analysis:am		\$163		
88269	TC	Chromosome analysis:am		\$326		
88271		Cytogenetics, dna probe		BR		
88272		Cytogenetics, 3-5.....		BR		
88273		Cytogenetics, 10-30...		BR		
88274		Cytogenetics, 25-99...		BR		
88275		Cytogenetics, 100-300		BR		
88280		Chromosome karyotype s		\$114		
88280	26	Chromosome karyotype s		\$35		
88280	TC	Chromosome karyotype s		\$79		
88283		Chromosome banding stu		\$224		
88283	26	Chromosome banding stu		\$67		
88283	TC	Chromosome banding stu		\$157		
88285		Chromosome count: addi		\$61		
88285	26	Chromosome count: addi		\$18		
88285	TC	Chromosome count: addi		\$43		
88289		Chromosome study: addi		\$114		
88289	26	Chromosome study: addi		\$35		
88289	TC	Chromosome study: addi		\$79		
88291		Cyto/molecular report		\$52		
88299		Cytogenetic study		BR		
88299	26	Cytogenetic study		BR		
88299	TC	Cytogenetic study		BR		
88300		Surg path, gross		\$47		
88300	26	Surg path, gross		\$37		
88300	TC	Surg path, gross		\$10		
88302		Tissue exam by pathologist		\$99		
88302	26	Tissue exam by pathologist		\$79		
88302	TC	Tissue exam by pathologist		\$20		
88304		Tissue exam by pathologist		\$128		
88304	26	Tissue exam by pathologist		\$102		
88304	TC	Tissue exam by pathologist		\$26		
88305		Tissue exam by pathologist		\$130		
88305	26	Tissue exam by pathologist		\$91		
88305	TC	Tissue exam by pathologist		\$39		
88307		Tissue exam by pathologist		\$229		
88307	26	Tissue exam by pathologist		\$170		
88307	TC	Tissue exam by pathologist		\$59		
88309		Tissue exam by pathologist		\$591		

Title 40, Part I

CPT Code	Mod	Description	Global Days	Maximum Allowance	Non-Facility Maximum	Facility Maximum
88309	26	Tissue exam by pathologist		\$473		
88309	TC	Tissue exam by pathologist		\$118		
88311		Decalcify tissue		\$45		
88311	26	Decalcify tissue		\$37		
88311	TC	Decalcify tissue		\$8		
88312		Special stains		\$45		
88312	26	Special stains		\$14		
88312	TC	Special stains		\$31		
88313		Special stains		\$45		
88313	26	Special stains		\$14		
88313	TC	Special stains		\$31		
88314		Histochemical stain		\$41		
88314	26	Histochemical stain		\$12		
88314	TC	Histochemical stain		\$29		
88319		Enzyme histochemistry		\$50		
88319	26	Enzyme histochemistry		\$24		
88319	TC	Enzyme histochemistry		\$26		
88321		Microslide consultation		\$81		
88323		Microslide consultation		\$143		
88323	26	Microslide consultation		\$143		
88323	TC	Microslide consultation		\$0		
88325		Comprehensive review o		\$102		
88325	26	Comprehensive review o		\$102		
88325	TC	Comprehensive review o		\$0		
88329		Pathology consult in s		\$96		
88329	26	Pathology consult in s		\$96		
88329	TC	Pathology consult in s		\$0		
88331		Pathology consult in s		\$189		
88331	26	Pathology consult in s		\$128		
88331	TC	Pathology consult in s		\$61		
88332		Pathology consult in s		\$100		
88332	26	Pathology consult in s		\$67		
88332	TC	Pathology consult in s		\$33		
88334	26	Intraop cyto path consult 2		\$77		
88334	TC	Intraop cyto path consult 2		\$49		
88334		Intraop cyto path consult 2		\$126		
88342		Immunocytochemistry		\$100		
88342	26	Immunocytochemistry		\$67		
88342	TC	Immunocytochemistry		\$33		
88346		Immunofluorescent stud		\$204		
88346	26	Immunofluorescent stud		\$143		
88346	TC	Immunofluorescent stud		\$61		
88347		Immunofluorescent stud		\$244		
88347	26	Immunofluorescent stud		\$183		
88347	TC	Immunofluorescent stud		\$61		
88348		Electron microscopy		\$351		
88348	26	Electron microscopy		\$267		
88348	TC	Electron microscopy		\$84		
88349		Scanning electron micr		\$351		
88349	26	Scanning electron micr		\$267		
88349	TC	Scanning electron micr		\$84		
88355		Analysis, skeletal mus		\$200		
88355	26	Analysis, skeletal mus		\$149		
88355	TC	Analysis, skeletal mus		\$51		
88356		Analysis, nerve		\$200		
88356	26	Analysis, nerve		\$149		
88356	TC	Analysis, nerve		\$51		
88358		Analysis, tumor		\$200		
88358	26	Analysis, tumor		\$149		
88358	TC	Analysis, tumor		\$51		
88360	26	Tumor immunohistochem/manual		\$106		
88360	TC	Tumor immunohistochem/manual		\$139		
88360		Tumor immunohistochem/manual		\$245		
88361	26	Tumor immunohistochem/comput		\$116		
88361	TC	Tumor immunohistochem/comput		\$190		
88361		Tumor immunohistochem/comput		\$306		

LABOR AND EMPLOYMENT

CPT Code	Mod	Description	Global Days	Maximum Allowance	Non-Facility Maximum	Facility Maximum
88362		Nerve teasing preparations		\$635		
88362	26	Nerve teasing preparations		\$224		
88362	TC	Nerve teasing preparations		\$412		
88363		Xm archive tissue molec anal			\$73	\$32
88365		Tissue hybridization		\$47		
88365	26	Tissue hybridization		\$47		
88365	TC	Tissue hybridization		\$0		
88367	26	Insitu hybridization auto		\$126		
88367	TC	Insitu hybridization auto		\$419		
88367		Insitu hybridization auto		\$544		
88368	26	Insitu hybridization manual		\$126		
88368	TC	Insitu hybridization manual		\$324		
88368		Insitu hybridization manual		\$451		
88371		Protein, western blot		BR		
88371	26	Protein, western blot		\$39		
88371	TC	Protein, western blot		BR		
88372		Protein analysis w/pro		BR		
88372	26	Protein analysis w/pro		\$33		
88372	TC	Protein analysis w/pro		BR		
88380	26	Microdissection laser		\$155		
88380	TC	Microdissection laser		\$204		
88380		Microdissection laser		\$359		
88381	26	Microdissection manual		\$102		
88381	TC	Microdissection manual		\$183		
88381		Microdissection manual		\$284		
88385	26	Eval molecu probes 51-250		\$127		
88385	TC	Eval molecu probes 51-250		\$978		
88385		Eval molecu probes 51-250		\$1,104		
88386	26	Eval molecu probes 251-500		\$166		
88386	TC	Eval molecu probes 251-500		\$1,029		
88386		Eval molecu probes 251-500		\$1,195		
88387	26	Tiss exam molecular study		\$13		
88387	TC	Tiss exam molecular study		\$59		
88387		Tiss exam molecular study		\$72		
88388	26	Tiss ex molecu study add-on		\$47		
88388	TC	Tiss ex molecu study add-on		\$17		
88388		Tiss ex molecu study add-on		\$63		
88399		Surgical pathology pro		BR		
88399	26	Surgical pathology pro		BR		
88399	TC	Surgical pathology pro		BR		
89049		Chct for mal hyperthermia		\$545		
89050		Body fluid cell count		\$18		
89050	26	Body fluid cell count		\$6		
89050	TC	Body fluid cell count		\$12		
89051		Body fluid cell count		\$24		
89051	26	Body fluid cell count		\$8		
89051	TC	Body fluid cell count		\$16		
89060		Exam,synovial fluid cr		\$24		
89060	26	Exam,synovial fluid cr		\$8		
89060	TC	Exam,synovial fluid cr		\$16		
89125		Specimen fat stain		\$26		
89125	26	Specimen fat stain		\$8		
89125	TC	Specimen fat stain		\$18		
89160		Exam feces for meat fibers		\$12		
89160	26	Exam feces for meat fibers		\$4		
89160	TC	Exam feces for meat fibers		\$8		
89190		Nasal smear for eosino		\$18		
89190	26	Nasal smear for eosino		\$6		
89190	TC	Nasal smear for eosino		\$12		
89220		Sputum specimen collection		\$33		
89230		Collect sweat for test		\$5		
89250		Fertilization of oocyte		BR		
89251		Culture oocyte w/ embryos		BR		
89252		Assist oocyte fertilization		BR		
89253		Embryo hatching.....		BR		
89254		Oocyte identification		BR		

Title 40, Part I

CPT Code	Mod	Description	Global Days	Maximum Allowance	Non-Facility Maximum	Facility Maximum
89255		Prepare embryo for transfer		BR		
89256		Prepare cryopreserved embryo		BR		
89257		Sperm identification..		BR		
89258		Cryopreservation, embryo		BR		
89259		Cryopreservation, sperm		BR		
89260		Sperm isolation, simple		BR		
89261		Sperm isolation, complex		BR		
89264		Identify sperm tissue		BR		
89300		Semen analysis.....		\$39		
89300	26	Semen analysis.....		\$13		
89300	TC	Semen analysis.....		\$26		
89310		Semen analysis		\$36		
89310	26	Semen analysis		\$10		
89310	TC	Semen analysis		\$26		
89320		Semen analysis		\$43		
89320	26	Semen analysis		\$12		
89320	TC	Semen analysis		\$31		
89325		Sperm antibody test		\$36		
89325	26	Sperm antibody test		\$10		
89325	TC	Sperm antibody test		\$26		
89329		Sperm evaluation test		\$128		
89329	26	Sperm evaluation test		\$47		
89329	TC	Sperm evaluation test		\$81		
89330		Evaluation, cervical m		\$36		
89330	26	Evaluation, cervical m		\$10		
89330	TC	Evaluation, cervical m		\$26		
90281		Human ig, im.....		BR		
90283		Human ig, iv.....		BR		
90287		Botulinum antitoxin...		BR		
90288		Botulism ig, iv.....		BR		
90291		Cmv ig, iv.....		BR		
90296		Diphtheria antitoxin..		BR		
90371		Hep b ig, im.....		BR		
90375		Rabies ig, im/sc.....		BR		
90376		Rabies ig, heat treated.		BR		
90378		Rsv ig, im.....		BR		
90379		Rsv ig, iv.....		BR		
90384		Rh ig, full-dose, im..		BR		
90385		Rh ig, minidose, im..		BR		
90386		Rh ig, iv.....		BR		
90389		Tetanus ig, im.....		BR		
90393		Vaccina ig, im.....		BR		
90396		Varicella-zoster ig, im		BR		
90399		Immune globulin.....		BR		
90460		Im admin 1st/only component		\$50		
90461		Im admin each addl component		\$26		
90471		Immunization admin....		\$51		
90472		Immunization admin, each add		\$26		
90473		Immune admin oral/nasal		\$50		
90474		Immune admin oral/nasal addl		\$26		
90476		Adenovirus vaccine, type 4		BR		
90477		Adenovirus vaccine, type 7		BR		
90581		Anthrax vaccine, sc...		BR		
90585		Bcg vaccine, percut...		BR		
90586		Bcg vaccine, intravesical		BR		
90632		Hep a vaccine, adult im		BR		
90633		Hep a vacc, ped/adol, 2 dose		BR		
90634		Hep a vacc, ped/adol, 3 dose		BR		
90636		Hep a/hep b vacc, adult im		BR		
90645		Hib vaccine, hboc, im		BR		
90646		Hib vaccine, prp-d, im		BR		
90647		Hib vaccine, prp-omp, im		BR		
90648		Hib vaccine, prp-t, im		BR		
90657		Flu vaccine, 6-35 mo, im		BR		
90658		Flu vaccine, 3 yrs, im		BR		
90660		Flu vaccine, nasal....		BR		

LABOR AND EMPLOYMENT

CPT Code	Mod	Description	Global Days	Maximum Allowance	Non-Facility Maximum	Facility Maximum
90665		Lyme disease vaccine, im		BR		
90669		Pneumococcal vaccine, ped		BR		
90675		Rabies vaccine, im....		BR		
90676		Rabies vaccine, id....		BR		
90680		Rotovirus vaccine, oral		BR		
90690		Typhoid vaccine, oral		BR		
90691		Typhoid vaccine, im...		BR		
90692		Typhoid vaccine, h-p, sc/id		BR		
90693		Typhoid vaccine, akd, sc		BR		
90700		Dtap vaccine, im.....		BR		
90701		Dtp vaccine, im.....		BR		
90702		Dt vaccine, im.....		BR		
90703		Tetanus vaccine, im...		BR		
90704		Mumps vaccine, sc....		BR		
90705		Measles vaccine, sc...		BR		
90706		Rubella vaccine, sc...		BR		
90707		Mmr vaccine, sc.....		BR		
90708		Measles-rubella vaccine, sc		BR		
90710		Mmr vaccine, sc.....		BR		
90712		Oral poliovirus vaccine		BR		
90713		Poliovirus, ipv, sc...		BR		
90716		Chicken pox vaccine, sc		BR		
90717		Yellow fever vaccine, sc		BR		
90718		Td vaccine, im.....		BR		
90719		Diphtheria vaccine, im		BR		
90720		Dtp/hib vaccine, im...		BR		
90721		Dtap/hib vaccine, im..		BR		
90725		Cholera vaccine, injectable		BR		
90727		Plague vaccine, im....		BR		
90732		Pneumococcal vaccine, adult		BR		
90733		Meningococcal vaccine, sc		BR		
90735		Encephalitis vaccine, sc		BR		
90744		Hep b vaccine, ped/ adol, im		BR		
90746		Hep b vaccine, adult, im		BR		
90747		Hep b vaccine, ill pat, im		BR		
90748		Hep b/hib vaccine, im		BR		
90749		Vaccine toxoid.....		BR		
90791		Psychiatric Diagnostic Evaluation		BR		
90792		Psychiatric Diagnostic Eval W/Medical Services		BR		
90801		Psy dx interview.....		\$257		
90802		Intac psy dx interview		\$255		
90804		Psytx, office, 20-30 min		\$116		
90805		Psytx, off, 20-30 min w/e&m		\$127		
90806		Psytx, off, 45-50 min		\$178		
90807		Psytx, off, 45-50 min w/e&m		\$189		
90808		Psytx, office, 75-80 min		\$283		
90809		Psytx, off, 75-80, w/ e&m		\$292		
90810		Intac psytx, off, 20- 30 min		\$140		
90811		Intac psytx, 20-30, w/ e&m		\$152		
90812		Intac psytx, off, 45- 50 min		\$191		
90813		Intac psytx, 45-50 min w/e&m		\$201		
90814		Intac psytx, off, 75- 80 min		\$262		
90815		Intac psytx, 75-80 w/ e&m		\$272		
90816		Psytx, hosp, 20-30 min		\$120		
90817		Psytx, hosp, 20-30 min w/e&m		\$131		
90818		Psytx, hosp, 45-50 min		\$181		
90819		Psytx, hosp, 45-50 min w/e&m		\$192		
90821		Psytx, hosp, 75-80 min		\$286		
90822		Psytx, hosp, 75-80 min w/e&m		\$296		
90823		Intac psytx, hosp, 20- 30 min		\$145		
90824		Intac psytx, hsp 20-30 w/e&m		\$155		
90826		Intac psytx, hosp, 45- 50 min		\$194		
90827		Intac psytx, hsp 45-50 w/e&m		\$204		
90828		Intac psytx, hosp, 75- 80 min		\$267		
90829		Intac psytx, hsp 75-80 w/e&m		\$274		



Title 40, Part I

CPT Code	Mod	Description	Global Days	Maximum Allowance	Non-Facility Maximum	Facility Maximum
90832		Psychotherapy W/Patient 30 Minutes		BR		
90833		Psychotherapy W/Patient W/E&M Srvc 30 Min		BR		
90834		Psychotherapy W/Patient 45 Minutes		BR		
90836		Psychotherapy W/Patient W/E&M Srvc 45 Min		BR		
90837		Psychotherapy W/Patient 60 Minutes		BR		
90838		Psychotherapy W/Patient W/E&M Srvc 60 Min		BR		
90845		Psychoanalysis.....		\$162		
90846		Family psytx w/o patient		\$180		
90847		Family psytx w/patient		\$206		
90849		Multiple family group psytx		\$63		
90853		Group psychotherapy...		\$63		
90857		Intac group psytx.....		\$59		
90862		Medication management		\$97		
90863		Pharmacologic Management W/Psychotherapy		BR		
90865		Narcosynthesis.....		\$307		
90867		Tcranial magn stim tx plan			\$772	\$357
90868		Tcranial magn stim tx deli			\$372	\$49
90869		Tcran magn stim redetemine			\$954	\$238
90870		Electroconvulsive therapy	0	\$178		
90875		Psychophysiological therapy		\$135		
90876		Psychophysiological therapy		\$204		
90880		Hypnotherapy.....		\$208		
90882		Environmental manipulation		BR		
90885		Psy evaluation of records		\$94		
90887		Consultation with family		\$131		
90889		Preparation of report		BR		
90899		Psychiatric service/therapy		BR		
90901		Biofeedback train, any meth	0	\$98		
90911		Biofeedback peri/uro/ rectal	0	\$153		
90935		Hemodialysis, one evaluation	0	\$193		
90937		Hemodialysis, repeated eval	0	\$348		
90945		Dialysis, one evaluation	0	\$179		
90947		Dialysis, repeated eval	0	\$302		
90951		Esrdr serv 4 visits p mo <2		\$1,902		
90954		Esrdr serv 4 vsts p mo 2-11		\$1,650		
90955		Esrdr srv 2-3 vsts p mo 2-11		\$930		
90956		Esrdr srv 1 visit p mo 2-11		\$646		
90957		Esrdr srv 4 vsts p mo 12-19		\$1,313		
90958		Esrdr srv 2-3 vsts p mo 12-19		\$890		
90959		Esrdr serv 1 vst p mo 12-19		\$603		
90960		Esrdr srv 4 visits p mo 20+		\$581		
90961		Esrdr srv 2-3 vsts p mo 20+		\$488		
90962		Esrdr serv 1 visit p mo 20+		\$378		
90963		Esrdr home pt serv p mo <2		\$1,109		
90964		Esrdr home pt serv p mo 2-11		\$967		
90965		Esrdr home pt serv p mo 12-19		\$922		
90966		Esrdr home pt serv p mo 20+		\$488		
90967		Esrdr home pt serv p day <2		\$36		
90968		Esrdr home pt serv p day 2-11		\$31		
90969		Esrdr home pt serv p day 12-19		\$30		
90970		Esrdr home pt serv p day 20+		\$16		
90989		Dialysis training/complete		BR		
90993		Dialysis training/incomplete		BR		
90997		Hemoperfusion	0	\$308		
90999		Dialysis procedure		BR		
91010		Esophagus motility study	0	\$241		
91010	26	Esophagus motility study	0	\$179		
91010	TC	Esophagus motility study	0	\$62		
91013	26	Esophgl motil w/stim/perfus		\$20		
91013	TC	Esophgl motil w/stim/perfus		\$30		
91013		Esophgl motil w/stim/perfus		\$50		
91020		Gastric motility.....	0	\$262		
91020	26	Gastric motility.....	0	\$204		

LABOR AND EMPLOYMENT

CPT Code	Mod	Description	Global Days	Maximum Allowance	Non-Facility Maximum	Facility Maximum
91020	TC	Gastric motility.....	0	\$58		
91022	26	Duodenal motility study		\$160		
91022	TC	Duodenal motility study		\$204		
91022		Duodenal motility study		\$364		
91030		Acid perfusion of esophagus	0	\$128		
91030	26	Acid perfusion of esophagus	0	\$112		
91030	TC	Acid perfusion of esophagus	0	\$17		
91034	26	Gastroesophageal reflux test		\$106		
91034	TC	Gastroesophageal reflux test		\$294		
91034		Gastroesophageal reflux test		\$400		
91035	26	G-esoph reflx tst w/electrod		\$175		
91035	TC	G-esoph reflx tst w/electrod		\$851		
91035		G-esoph reflx tst w/electrod		\$1,026		
91037	26	Esoph imped function test		\$109		
91037	TC	Esoph imped function test		\$234		
91037		Esoph imped function test		\$343		
91038	26	Esoph imped funct test > 1h		\$122		
91038	TC	Esoph imped funct test > 1h		\$867		
91038		Esoph imped funct test > 1h		\$988		
91040	26	Esoph balloon distension tst		\$96		
91040	TC	Esoph balloon distension tst		\$496		
91040		Esoph balloon distension tst		\$592		
91065		Breath hydrogen test	0	\$94		
91065	26	Breath hydrogen test	0	\$69		
91065	TC	Breath hydrogen test	0	\$26		
91110	26	Gi tract capsule endoscopy		\$405		
91110	TC	Gi tract capsule endoscopy		\$1,495		
91110		Gi tract capsule endoscopy		\$1,900		
91111	26	Esophageal capsule endoscopy		\$110		
91111	TC	Esophageal capsule endoscopy		\$1,445		
91111		Esophageal capsule endoscopy		\$1,556		
91117		Colon motility 6 hr study			\$289	\$310
91120	26	Rectal sensation test		\$105		
91120	TC	Rectal sensation test		\$719		
91120		Rectal sensation test		\$824		
91122		Anal pressure record	0	\$264		
91122	26	Anal pressure record	0	\$210		
91122	TC	Anal pressure record	0	\$54		
91132	26	Electrogastrography		\$58		
91132	TC	Electrogastrography		\$270		
91132		Electrogastrography		\$328		
91133	26	Electrogastrography w/test		\$74		
91133	TC	Electrogastrography w/test		\$307		
91133		Electrogastrography w/test		\$381		
91299		Gastroenterology procedure		BR		
91299	26	Gastroenterology procedure	BR			
91299	TC	Gastroenterology procedure	BR			
92002		Eye exam, new patient		\$108		
92004		Eye exam, new patient		\$157		
92012		Eye exam established pt		\$91		
92014		Eye exam & treatment		\$115		
92015		Refraction			\$41	\$39
92018		New eye exam & treatment		\$143		
92019		Eye exam & treatment		\$129		
92020		Special eye evaluation		\$52		
92025	26	Corneal topography		\$41		
92025	TC	Corneal topography		\$37		
92025		Corneal topography		\$78		
92060		Special eye evaluation		\$81		
92060	26	Special eye evaluation		\$66		
92060	TC	Special eye evaluation		\$14		
92065		Orthoptic/pleoptic training		\$52		
92065	26	Orthoptic/pleoptic training		\$41		
92065	TC	Orthoptic/pleoptic training		\$12		
92071		Contact lens fitting for tx			\$77	\$69
92072		Fit contac lens for managmnt			\$246	\$197

Title 40, Part I

CPT Code	Mod	Description	Global Days	Maximum Allowance	Non-Facility Maximum	Facility Maximum
92081		Visual field examination(s)		\$49		
92081	26	Visual field examination(s)		\$38		
92081	TC	Visual field examination(s)		\$11		
92082		Visual field examination(s)		\$67		
92082	26	Visual field examination(s)		\$53		
92082	TC	Visual field examination(s)		\$14		
92083		Visual field examination(s)		\$98		
92083	26	Visual field examination(s)		\$77		
92083	TC	Visual field examination(s)		\$21		
92100		Serial tonometry exam(s)		\$91		
92132	26	Cmptr ophth dx img ant segmt		\$42		
92132	TC	Cmptr ophth dx img ant segmt		\$34		
92132		Cmptr ophth dx img ant segmt		\$77		
92133	26	Cmptr ophth img optic nerve		\$59		
92133	TC	Cmptr ophth img optic nerve		\$33		
92133		Cmptr ophth img optic nerve		\$93		
92134	26	Cptr ophth dx img post segmt		\$59		
92134	TC	Cptr ophth dx img post segmt		\$33		
92134		Cptr ophth dx img post segmt		\$93		
92136	26	Ophthalmic biometry		\$64		
92136	TC	Ophthalmic biometry		\$119		
92136		Ophthalmic biometry		\$183		
92140		Glaucoma provocative tests		\$67		
92225		Special eye exam, initial		\$73		
92226		Special eye exam, subsequent		\$66		
92227		Remote dx retinal imaging		\$25		
92228	26	Remote retinal imaging mgmt		\$43		
92228	TC	Remote retinal imaging mgmt		\$28		
92228		Remote retinal imaging mgmt		\$71		
92230		Eye exam with photos..		\$119		
92235		Eye exam with photos..		\$175		
92235	26	Eye exam with photos..		\$98		
92235	TC	Eye exam with photos..		\$77		
92240		Icg angiography.....		\$199		
92240	26	Icg angiography.....		\$121		
92240	TC	Icg angiography.....		\$77		
92250		Eye exam with photos		\$63		
92250	26	Eye exam with photos		\$49		
92250	TC	Eye exam with photos		\$13		
92260		Ophthalmoscopy/dynamometry		\$77		
92265		Eye muscle evaluation		\$83		
92265	26	Eye muscle evaluation		\$65		
92265	TC	Eye muscle evaluation		\$18		
92270		Electro-oculography...		\$109		
92270	26	Electro-oculography...		\$84		
92270	TC	Electro-oculography...		\$24		
92275		Electroretinography...		\$138		
92275	26	Electroretinography...		\$108		
92275	TC	Electroretinography...		\$30		
92283		Color vision examination		\$40		
92283	26	Color vision examination		\$31		
92283	TC	Color vision examination		\$9		
92284		Dark adaptation eye exam		\$47		
92284	26	Dark adaptation eye exam		\$34		
92284	TC	Dark adaptation eye exam		\$13		
92285		Eye photography.....		\$35		
92285	26	Eye photography.....		\$26		
92285	TC	Eye photography.....		\$8		
92286		Internal eye photography		\$131		
92286	26	Internal eye photography		\$101		
92286	TC	Internal eye photography		\$30		
92287		Internal eye photography		\$171		
92310		Contact lens fitting		BR		
92311		Contact lens fitting		\$143		
92312		Contact lens fitting		\$173		
92313		Contact lens fitting		\$130		

LABOR AND EMPLOYMENT

CPT Code	Mod	Description	Global Days	Maximum Allowance	Non-Facility Maximum	Facility Maximum
92314		Prescription of contact lens		BR		
92315		Prescription of contact lens		\$82		
92316		Prescription of contact lens		\$119		
92317		Prescription of contact lens		\$61		
92325		Modification of contact lens		\$28		
92326		Replacement of contact lens		\$115		
92340		Fitting of spectacles			\$71	\$38
92341		Fitting of spectacles			\$81	\$48
92342		Fitting of spectacles			\$88	\$55
92352		Special spectacles fitting		\$48		
92353		Special spectacles fitting		\$65		
92354		Special spectacles fitting		\$605		
92355		Special spectacles fitting		\$294		
92358		Eye prosthesis service		\$69		
92370		Repair & adjust spectacles			\$63	\$34
92371		Repair & adjust spectacles		\$44		
92502		Ear and throat examination	0	\$195		
92504		Ear microscopy examination		\$33		
92506		Speech/hearing evaluation		\$109		
92507		Speech/hearing therapy		\$72		
92508		Speech/hearing therapy		\$41		
92511		Nasopharyngoscopy	0	\$126		
92512		Nasal function studies		\$77		
92516		Facial nerve function test		\$66		
92520		Laryngeal function studies		\$96		
92521		Evaluation Of Speech Fluency (Stutter Clutter)		BR		
92522		Evaluation Of Speech Sound Production Articulate		BR		
92523		Eval Speech Sound Product Language Comprehension		BR		
92524		Behavioral & Qualit Analysis Voice And Resonance		BR		
92526		Oral function therapy		\$86		
92531		Spontaneous nystagmus study		BR		
92532		Positional nystagmus study		BR		
92533		Caloric vestibular test		BR		
92534		Optokinetic nystagmus		BR		
92541		Spontaneous nystagmus test		\$81		
92541	26	Spontaneous nystagmus test		\$64		
92541	TC	Spontaneous nystagmus test		\$17		
92542		Positional nystagmus test		\$71		
92542	26	Positional nystagmus test		\$52		
92542	TC	Positional nystagmus test		\$20		
92543		Caloric vestibular test		\$91		
92543	26	Caloric vestibular test		\$60		
92543	TC	Caloric vestibular test		\$31		
92544		Optokinetic nystagmus test		\$55		
92544	26	Optokinetic nystagmus test		\$40		
92544	TC	Optokinetic nystagmus test		\$16		
92545		Oscillating tracking test		\$47		
92545	26	Oscillating tracking test		\$32		
92545	TC	Oscillating tracking test		\$16		
92546		Sinusoidal rotational test		\$60		
92546	26	Sinusoidal rotational test		\$41		
92546	TC	Sinusoidal rotational test		\$19		
92547		Supplemental electrical test		\$44		
92548		Posturography.....		\$181		
92548	26	Posturography.....		\$68		
92548	TC	Posturography.....		\$113		
92551		Pure tone hearing test, air		\$24		
92552		Pure tone audiometry, air		\$33		
92553		Audiometry, air & bone		\$50		
92555		Speech threshold audiometry		\$29		
92556		Speech audiometry, complete		\$44		
92557		Comprehensive hearing test		\$92		
92559		Group audiometric testing		BR		

Title 40, Part I

CPT Code	Mod	Description	Global Days	Maximum Allowance	Non-Facility Maximum	Facility Maximum
92560		Bekesy audiometry, screen		BR		
92561		Bekesy audiometry, diagnosis		\$54		
92562		Loudness balance test		\$31		
92563		Tone decay hearing test		\$28		
92564		Sisi hearing test		\$35		
92565		Stenger test, pure tone		\$30		
92567		Tympanometry		\$40		
92568		Acoustic reflex testing		\$28		
92570		Acoustic immitance testing			\$66	\$61
92571		Filtered speech hearing test		\$29		
92572		Staggered spondaic word test		\$7		
92575		Sensorineural acuity test		\$23		
92576		Synthetic sentence test		\$33		
92577		Stenger test, speech		\$54		
92579		Visual audiometry (vra)		\$55		
92582		Conditioning play audiometry		\$54		
92583		Select picture audiometry		\$67		
92584		Electrocochleography		\$185		
92585		Auditory evoked potential		\$272		
92585	26	Auditory evoked potential		\$131		
92585	TC	Auditory evoked potential		\$141		
92586		Auditor evoke potent limit		\$174		
92587		Evoked auditory test		\$113		
92587	26	Evoked auditory test		\$18		
92587	TC	Evoked auditory test		\$95		
92588		Evoked auditory test..		\$159		
92588	26	Evoked auditory test..		\$47		
92588	TC	Evoked auditory test..		\$113		
92589		Auditory function test(s)		\$41		
92590		Hearing aid exam, one ear		BR		
92591		Hearing aid exam, both ears		BR		
92592		Hearing aid check, one ear		BR		
92593		Hearing aid check, both ears		BR		
92594		Electro hearing aid test,one		BR		
92595		Electro hearing aid test,both		BR		
92596		Ear protector evaluation		\$45		
92597		Oral speech device eval		\$182		
92601		Cochlear implt f/up exam < 7			\$286	\$244
92602		Reprogram cochlear implt < 7			\$183	\$139
92603		Cochlear implt f/up exam 7 >			\$302	\$249
92604		Reprogram cochlear implt 7 >			\$181	\$138
92605		Ex for nonspeech device rx			\$187	\$179
92606		Non-speech device service			\$167	\$143
92607		Ex for speech device rx 1hr		\$232		
92608		Ex for speech device rx addl		\$88		
92609		Use of speech device service		\$180		
92610		Evaluate swallowing function			\$155	\$138
92611		Motion fluoroscopy/swallow		\$174		
92612		Endoscopy swallow tst (fees)			\$351	\$139
92613		Endoscopy swallow tst (fees)		\$79		
92614		Laryngoscopic sensory test			\$316	\$141
92615		Eval laryngoscopy sense tst			\$70	\$69
92616		Fees w/laryngeal sense test			\$421	\$205
92617		Interprt fees/laryngeal test			\$86	\$85
92618		Ex for nonspeech dev rx add			\$67	\$66
92620		Auditory function 60 min			\$192	\$169
92621		Auditory function + 15 min			\$46	\$39
92625		Tinnitus assessment			\$143	\$127
92626		Eval aud rehab status			\$185	\$155
92627		Eval aud status rehab add-on			\$46	\$36
92640		Aud brainstem implt program			\$251	\$213
92950		Heart/lung resuscitation(cpr)	0	\$442		
92953		Temporary external pacing	0	\$137		
92960		Cardioversion electric, ext	0	\$302		
92961		Cardioversion, electric, int	0	BR		
92970		Cardioassist, internal	0	\$524		

LABOR AND EMPLOYMENT

CPT Code	Mod	Description	Global Days	Maximum Allowance	Non-Facility Maximum	Facility Maximum
92971		Cardioassist, external	0	\$210		
92973		Percut coronary thrombectomy		\$365		
92974		Cath place cardio brachytx		\$333		
92975		Dissolve clot, heart vessel	0	\$947		
92977		Dissolve clot, heart vessel		\$583		
92978		Intravasc us, heart add-on		\$544		
92978	26	Intravasc us, heart add-on		\$203		
92978	TC	Intravasc us, heart add-on		\$341		
92979		Intravasc us, heart add-on		\$334		
92979	26	Intravasc us, heart add-on		\$163		
92979	TC	Intravasc us, heart add-on		\$171		
92980		Insert intracoronary stent	0	\$2,273		
92981		Insert intracoronary stent		\$608		
92982		Coronary artery dilation	0	\$1,929		
92984		Coronary artery dilation		\$442		
92986		Revision of aortic valve	90	\$2,356		
92987		Revision of mitral valve	90	\$1,124		
92990		Revision of pulmonary valve	90	\$1,878		
92992		Revision of heart chamber	90	BR		
92993		Revision of heart chamber	90	BR		
92995		Coronary atherectomy..	0	\$1,103		
92996		Coronary atherectomy add-on		\$481		
92997		Pul art balloon repr, percut	0	\$1,067		
92998		Pul art balloon repr, percut		\$700		
93000		Electrocardiogram, complete		\$56		
93005		Electrocardiogram, tracing		\$33		
93010		Electrocardiogram report		\$24		
93015		Cardiovascular stress test		\$233		
93016		Cardiovascular stress test		\$61		
93017		Cardiovascular stress test		\$122		
93018		Cardiovascular stress test		\$50		
93024		Cardiac drug stress test		\$285		
93024	26	Cardiac drug stress test		\$203		
93024	TC	Cardiac drug stress test		\$82		
93025	26	Microvolt t-wave assess		\$76		
93025	TC	Microvolt t-wave assess		\$259		
93025		Microvolt t-wave assess		\$335		
93040		Rhythm ecg with report		\$31		
93041		Rhythm ecg, tracing		\$11		
93042		Rhythm ecg, report		\$21		
93224		Ecg monitor/report, 24 hrs		\$345		
93225		Ecg monitor/record, 24 hrs		\$90		
93226		Ecg monitor/report, 24 hrs		\$159		
93227		Ecg monitor/review, 24 hrs		\$97		
93228		Remote 30 day ecg rev/report		\$52		
93229	26	Remote 30 day ecg tech supp		\$1,423		
93268		ECG record/review.....		\$284		
93268	26	ECG record/review.....		BR		
93268	TC	ECG record/review.....		BR		
93270		ECG recording		\$89		
93271		ECG/monitoring and analysis		\$173		
93272		ECG/review, interpret only		\$68		
93278		Ecg/signal-averaged		\$161		
93278	26	Ecg/signal-averaged		\$75		
93278	TC	Ecg/signal-averaged		\$87		
93279	TC	Pm device progr eval sngl		\$65		
93279	26	Pm device progr eval sngl		\$34		
93279		Pm device progr eval sngl		\$99		
93280	26	Pm device progr eval dual		\$77		
93280	TC	Pm device progr eval dual		\$38		
93280		Pm device progr eval dual		\$115		
93281	26	Pm device progr eval multi		\$89		
93281	TC	Pm device progr eval multi		\$45		
93281		Pm device progr eval multi		\$134		
93282	26	Icd device prog eval 1 sngl		\$84		
93282	TC	Icd device prog eval 1 sngl		\$39		

Title 40, Part I

CPT Code	Mod	Description	Global Days	Maximum Allowance	Non-Facility Maximum	Facility Maximum
93282		Icd device prog eval 1 snl		\$123		
93283	26	Icd device progr eval dual		\$114		
93283	TC	Icd device progr eval dual		\$45		
93283		Icd device progr eval dual		\$159		
93284	26	Icd device progr eval mult		\$124		
93284	TC	Icd device progr eval mult		\$52		
93284		Icd device progr eval mult		\$176		
93285	26	Ilr device eval progr		\$51		
93285	TC	Ilr device eval progr		\$31		
93285		Ilr device eval progr		\$82		
93286	26	Pre-op pm device eval		\$30		
93286	TC	Pre-op pm device eval		\$22		
93286		Pre-op pm device eval		\$52		
93287	26	Pre-op icd device eval		\$45		
93287	TC	Pre-op icd device eval		\$25		
93287		Pre-op icd device eval		\$70		
93288	26	Pm device eval in person		\$43		
93288	TC	Pm device eval in person		\$31		
93288		Pm device eval in person		\$74		
93289	26	Icd device interrogate		\$91		
93289	TC	Icd device interrogate		\$38		
93289		Icd device interrogate		\$130		
93290	26	Icm device eval		\$43		
93290	TC	Icm device eval		\$18		
93290		Icm device eval		\$61		
93291	26	Ilr device interrogate		\$43		
93291	TC	Ilr device interrogate		\$29		
93291		Ilr device interrogate		\$71		
93292	26	Wcd device interrogate		\$43		
93292	TC	Wcd device interrogate		\$22		
93292		Wcd device interrogate		\$64		
93293	26	Pm phone r-strip device eval		\$31		
93293	TC	Pm phone r-strip device eval		\$75		
93293		Pm phone r-strip device eval		\$107		
93294		Pm device interrogate remote		\$66		
93295		Icd device interogat remote		\$130		
93296		Pm/icd remote tech serv		\$52		
93297		Icm device interogat remote		\$52		
93298		Ilr device interogat remote		\$52		
93303		Echo transthoracic....		\$452		
93303	26	Echo transthoracic....		\$162		
93303	TC	Echo transthoracic....		\$291		
93304		Echo transthoracic....		\$245		
93304	26	Echo transthoracic....		\$99		
93304	TC	Echo transthoracic....		\$146		
93306	26	Tte w/doppler complete		\$129		
93306	TC	Tte w/doppler complete		\$261		
93306		Tte w/doppler complete		\$390		
93307		Echo exam of heart....		\$423		
93307	26	Echo exam of heart....		\$132		
93307	TC	Echo exam of heart....		\$291		
93308		Echo exam of heart		\$231		
93308	26	Echo exam of heart		\$90		
93308	TC	Echo exam of heart		\$141		
93312		Echo transesophageal..		\$539		
93312	26	Echo transesophageal..		\$250		
93312	TC	Echo transesophageal..		\$289		
93313		Echo exam of heart		\$119		
93314		Echo exam of heart		\$397		
93314	26	Echo exam of heart		\$119		
93314	TC	Echo exam of heart		\$278		
93315		Echo transesophageal..		\$584		
93315	26	Echo transesophageal..		\$295		
93315	TC	Echo transesophageal..		\$289		
93316		Echo transesophageal..		\$124		
93317		Echo transesophageal..		\$470		

LABOR AND EMPLOYMENT

CPT Code	Mod	Description	Global Days	Maximum Allowance	Non-Facility Maximum	Facility Maximum
93317	26	Echo transesophageal..		\$181		
93317	TC	Echo transesophageal..		\$289		
93318		Echo transesophageal intraop		\$228		
93320		Doppler echo exam, heart		\$185		
93320	26	Doppler echo exam, heart		\$56		
93320	TC	Doppler echo exam, heart		\$129		
93321		Doppler echo exam, heart		\$107		
93321	26	Doppler echo exam, heart		\$22		
93321	TC	Doppler echo exam, heart		\$84		
93325		Doppler color flow add on		\$229		
93325	26	Doppler color flow add on		\$8		
93325	TC	Doppler color flow add on		\$220		
93350		Echo transthoracic....		\$248		
93350	26	Echo transthoracic....		\$114		
93350	TC	Echo transthoracic....		\$133		
93351	26	Stress tte complete		\$174		
93351	TC	Stress tte complete		\$304		
93351		Stress tte complete		\$478		
93352		Admin ecg contrast agent		\$67		
93451	26	Right heart cath		\$303		
93451	TC	Right heart cath		\$1,343		
93451		Right heart cath		\$1,646		
93452	26	Left hrt cath w/ventrclgrphy		\$531		
93452	TC	Left hrt cath w/ventrclgrphy		\$1,283		
93452		Left hrt cath w/ventrclgrphy		\$1,813		
93453	26	R&l hrt cath w/ventriclgrphy		\$695		
93453	TC	R&l hrt cath w/ventriclgrphy		\$1,679		
93453		R&l hrt cath w/ventriclgrphy		\$2,374		
93454	26	Coronary artery angio s&i		\$534		
93454	TC	Coronary artery angio s&i		\$1,335		
93454		Coronary artery angio s&i		\$1,869		
93455	26	Coronary art/grft angio s&i		\$617		
93455	TC	Coronary art/grft angio s&i		\$1,565		
93455		Coronary art/grft angio s&i		\$2,183		
93456	26	R hrt coronary artery angio		\$684		
93456	TC	R hrt coronary artery angio		\$1,654		
93456		R hrt coronary artery angio		\$2,339		
93457	26	R hrt art/grft angio		\$767		
93457	TC	R hrt art/grft angio		\$1,884		
93457		R hrt art/grft angio		\$2,651		
93458	26	L hrt artery/ventricle angio		\$653		
93458	TC	L hrt artery/ventricle angio		\$1,603		
93458		L hrt artery/ventricle angio		\$2,256		
93459	26	L hrt art/grft angio		\$735		
93459	TC	L hrt art/grft angio		\$1,756		
93459		L hrt art/grft angio		\$2,491		
93460	26	R&l hrt art/ventricle angio		\$818		
93460	TC	R&l hrt art/ventricle angio		\$1,846		
93460		R&l hrt art/ventricle angio		\$2,664		
93461	26	R&l hrt art/ventricle angio		\$903		
93461	TC	R&l hrt art/ventricle angio		\$2,152		
93461		R&l hrt art/ventricle angio		\$3,055		
93462		L hrt cath trnsptl puncture		\$416		
93463		Drug admin & hemodynmic meas		\$220		
93464	26	Exercise w/hemodynamic meas		\$194		
93464	TC	Exercise w/hemodynamic meas		\$355		
93464		Exercise w/hemodynamic meas		\$549		
93503		Insert/place heart catheter	0	\$366		
93505		Biopsy of heart lining	0	\$703		
93505	26	Biopsy of heart lining	0	\$557		
93505	TC	Biopsy of heart lining	0	\$147		
93530		Rt heart cath, congenital	0	\$1,814		
93530	26	Rt heart cath, congenital	0	\$548		
93530	TC	Rt heart cath, congenital	0	\$1,266		
93531		R & l heart cath, congenital	0	\$4,588		
93531	26	R & l heart cath, congenital	0	\$973		



Title 40, Part I

CPT Code	Mod	Description	Global Days	Maximum Allowance	Non-Facility Maximum	Facility Maximum
93531	TC	R & l heart cath, congenital	0	\$3,615		
93532		R & l heart cath, congenital	0	\$4,016		
93532	26	R & l heart cath, congenital	0	\$497		
93532	TC	R & l heart cath, congenital	0	\$3,519		
93533		R & l heart cath, congenital	0	\$4,209		
93533	26	R & l heart cath, congenital	0	\$690		
93533	TC	R & l heart cath, congenital	0	\$3,519		
93536		Insert circulation assist	0	\$900		
93562			0	\$87		
93562	26		0	\$63		
93562	TC		0	\$24		
93563		Inject congenital card cath		\$115		
93564		Inject hrt congntl art/grft		\$117		
93565		Inject l ventr/atrial angio		\$89		
93566		Inject r ventr/atrial angio			\$369	\$87
93567		Inject suprvlv aortography			\$298	\$99
93568		Inject pulm art hrt cath			\$334	\$90
93571		Heart flow reserve measure		\$519		
93571	26	Heart flow reserve measure		\$178		
93571	TC	Heart flow reserve measure		\$341		
93572		Heart flow reserve measure		\$476		
93572	26	Heart flow reserve measure		\$143		
93572	TC	Heart flow reserve measure		\$333		
93580		Transcath closure of asd		\$2,029		
93581		Transcath closure of vsd		\$2,739		
93600		Bundle of his recording	0	\$518		
93600	26	Bundle of his recording	0	\$377		
93600	TC	Bundle of his recording	0	\$142		
93602		Intra-atrial recording	0	\$366		
93602	26	Intra-atrial recording	0	\$285		
93602	TC	Intra-atrial recording	0	\$81		
93603		Right ventricular recording	0	\$438		
93603	26	Right ventricular recording	0	\$316		
93603	TC	Right ventricular recording	0	\$122		
93609		Mapping of tachycardia	0	\$1,201		
93609	26	Mapping of tachycardia	0	\$1,004		
93609	TC	Mapping of tachycardia	0	\$197		
93610		Intra-atrial pacing	0	\$488		
93610	26	Intra-atrial pacing	0	\$390		
93610	TC	Intra-atrial pacing	0	\$98		
93612		Intraventricular pacing	0	\$509		
93612	26	Intraventricular pacing	0	\$392		
93612	TC	Intraventricular pacing	0	\$118		
93613		Electrophys map 3d add-on		\$779		
93615		Esophageal recording	0	\$119		
93615	26	Esophageal recording	0	\$96		
93615	TC	Esophageal recording	0	\$23		
93616		Esophageal recording	0	\$231		
93616	26	Esophageal recording	0	\$208		
93616	TC	Esophageal recording	0	\$23		
93618		Heart rhythm pacing	0	\$1,018		
93618	26	Heart rhythm pacing	0	\$731		
93618	TC	Heart rhythm pacing	0	\$287		
93619		Electrophysiology evaluation	0	\$1,647		
93619	26	Electrophysiology evaluation	0	\$1,067		
93619	TC	Electrophysiology evaluation	0	\$580		
93620		Electrophysiology evaluation	0	\$1,636		
93620	26	Electrophysiology evaluation	0	\$963		
93620	TC	Electrophysiology evaluation	0	\$673		
93621		Electrophysiology evaluation	0	BR		
93621	26	Electrophysiology evaluation	0	\$1,122		
93621	TC	Electrophysiology evaluation	0	BR		
93622		Electrophysiology evaluation	0	BR		
93622	26	Electrophysiology evaluation	0	\$1,129		
93622	TC	Electrophysiology evaluation	0	BR		
93623		Stimulation, pacing heart		BR		

LABOR AND EMPLOYMENT

CPT Code	Mod	Description	Global Days	Maximum Allowance	Non-Facility Maximum	Facility Maximum
93623	26	Stimulation, pacing heart		\$388		
93623	TC	Stimulation, pacing heart		BR		
93624		Electrophysiologic study	0	\$710		
93624	26	Electrophysiologic study	0	\$567		
93624	TC	Electrophysiologic study	0	\$144		
93631		Heart pacing, mapping	0	\$1,458		
93631	26	Heart pacing, mapping	0	\$993		
93631	TC	Heart pacing, mapping	0	\$465		
93640		Evaluation heart device	0	\$1,064		
93640	26	Evaluation heart device	0	\$525		
93640	TC	Evaluation heart device	0	\$539		
93641		Electrophysiology evaluation	0	\$1,398		
93641	26	Electrophysiology evaluation	0	\$859		
93641	TC	Electrophysiology evaluation	0	\$539		
93642		Electrophysiology evaluation	0	\$1,255		
93642	26	Electrophysiology evaluation	0	\$716		
93642	TC	Electrophysiology evaluation	0	\$539		
93650		Ablate heart dysrhythm focus	0	\$1,972		
93651		Ablate heart dysrhythm focus	0	\$2,507		
93652		Ablate heart dysrhythm focus	0	\$2,609		
93660		Tilt table evaluation	0	\$424		
93660	26	Tilt table evaluation	0	\$236		
93660	TC	Tilt table evaluation	0	\$188		
93662		Intracardiac ecg (ice)		\$285		
93668		Peripheral vascular rehab		\$39		
93701		Bioimpedance cv analysis		\$49		
93724		Analyze pacemaker system	0	\$852		
93724	26	Analyze pacemaker system	0	\$565		
93724	TC	Analyze pacemaker system	0	\$287		
93740		Temperature gradient studies		\$46		
93740	26	Temperature gradient studies		\$35		
93740	TC	Temperature gradient studies		\$12		
93750		Interrogation vad in person			\$109	\$91
93770		Measure venous pressure		\$27		
93770	26	Measure venous pressure		\$25		
93770	TC	Measure venous pressure		\$3		
93784		Ambulatory bp monitoring		\$112		
93786		Ambulatory bp recording		\$62		
93788		Ambulatory bp analysis		\$11		
93790		Review/report bp recording		\$38		
93797		Cardiac rehab	0	\$35		
93798		Cardiac rehab/monitor	0	\$56		
93799		Cardiovascular procedure		BR		
93799	26	Cardiovascular procedure		BR		
93799	TC	Cardiovascular procedure		BR		
93880		Extracranial study		\$341		
93880	26	Extracranial study		\$79		
93880	TC	Extracranial study		\$263		
93882		Extracranial study....		\$237		
93882	26	Extracranial study....		\$46		
93882	TC	Extracranial study....		\$191		
93886		Intracranial study		\$381		
93886	26	Intracranial study		\$119		
93886	TC	Intracranial study		\$263		
93888		Intracranial study....		\$282		
93888	26	Intracranial study....		\$64		
93888	TC	Intracranial study....		\$218		
93892	26	Tcd emboli detect w/o inj		\$118		
93892	TC	Tcd emboli detect w/o inj		\$567		
93892		Tcd emboli detect w/o inj		\$685		
93893	26	Tcd emboli detect w/inj		\$118		
93893	TC	Tcd emboli detect w/inj		\$576		
93893		Tcd emboli detect w/inj		\$694		
93922		Extremity study		\$130		
93922	26	Extremity study		\$42		
93922	TC	Extremity study		\$88		

Title 40, Part I

CPT Code	Mod	Description	Global Days	Maximum Allowance	Non-Facility Maximum	Facility Maximum
93923		Extremity study		\$245		
93923	26	Extremity study		\$80		
93923	TC	Extremity study		\$166		
93924		Extremity study		\$267		
93924	26	Extremity study		\$87		
93924	TC	Extremity study		\$181		
93925		Lower extremity study		\$341		
93925	26	Lower extremity study		\$79		
93925	TC	Lower extremity study		\$263		
93926		Lower extremity study		\$239		
93926	26	Lower extremity study		\$45		
93926	TC	Lower extremity study		\$193		
93930		Upper extremity study		\$328		
93930	26	Upper extremity study		\$66		
93930	TC	Upper extremity study		\$263		
93931		Upper extremity study		\$245		
93931	26	Upper extremity study		\$40		
93931	TC	Upper extremity study		\$205		
93965		Extremity study		\$143		
93965	26	Extremity study		\$61		
93965	TC	Extremity study		\$83		
93970		Extremity study		\$355		
93970	26	Extremity study		\$93		
93970	TC	Extremity study		\$263		
93971		Extremity study.....		\$264		
93971	26	Extremity study.....		\$50		
93971	TC	Extremity study.....		\$213		
93975		Vascular study.....		\$526		
93975	26	Vascular study.....		\$162		
93975	TC	Vascular study.....		\$364		
93976		Vascular study.....		\$351		
93976	26	Vascular study.....		\$108		
93976	TC	Vascular study.....		\$243		
93978		Vascular study		\$350		
93978	26	Vascular study		\$88		
93978	TC	Vascular study		\$263		
93979		Vascular study.....		\$248		
93979	26	Vascular study.....		\$50		
93979	TC	Vascular study.....		\$199		
93980		Penile vascular study		\$455		
93980	26	Penile vascular study		\$192		
93980	TC	Penile vascular study		\$263		
93981		Penile vascular study		\$318		
93981	26	Penile vascular study		\$76		
93981	TC	Penile vascular study		\$243		
93982		Aneurysm pressure sens study		\$88		
93990		Doppler flow testing		\$218		
93990	26	Doppler flow testing		\$32		
93990	TC	Doppler flow testing		\$186		
94002		Vent mgmt inpat init day		\$193		
94003		Vent mgmt inpat subq day		\$137		
94004		Vent mgmt nf per day		\$101		
94005		Home vent mgmt supervision		\$189		
94010		Breathing capacity test		\$61		
94010	26	Breathing capacity test		\$30		
94010	TC	Breathing capacity test		\$31		
94011		Spirometry up to 2 yrs old		\$209		
94012		Spirmetry w/brnchdil inf-2 yr		\$330		
94013		Meas lung vol thru 2 yrs		\$69		
94014		Patient recorded spirometry		\$83		
94015		Patient recorded spirometry		BR		
94016		Review patient spirometry		\$52		
94060		Evaluation of wheezing		\$114		
94060	26	Evaluation of wheezing		\$44		
94060	TC	Evaluation of wheezing		\$70		
94070		Evaluation of wheezing		\$177		

LABOR AND EMPLOYMENT

CPT Code	Mod	Description	Global Days	Maximum Allowance	Non-Facility Maximum	Facility Maximum
94070	26	Evaluation of wheezing		\$68		
94070	TC	Evaluation of wheezing		\$110		
94150		Vital capacity test		\$24		
94150	26	Vital capacity test		\$17		
94150	TC	Vital capacity test		\$7		
94200		Lung function test (mbc/mvv)		\$38		
94200	26	Lung function test (mbc/mvv)		\$20		
94200	TC	Lung function test (mbc/mvv)		\$19		
94250		Expired gas collection		\$28		
94250	26	Expired gas collection		\$19		
94250	TC	Expired gas collection		\$10		
94375		Respiratory flow volume loop		\$73		
94375	26	Respiratory flow volume loop		\$38		
94375	TC	Respiratory flow volume loop		\$35		
94400		Co2 breathing response curve		\$96		
94400	26	Co2 breathing response curve		\$71		
94400	TC	Co2 breathing response curve		\$26		
94450		Hypoxia response curve		\$75		
94450	26	Hypoxia response curve		\$47		
94450	TC	Hypoxia response curve		\$28		
94452	26	Hast w/report		\$30		
94452	TC	Hast w/report		\$89		
94452		Hast w/report		\$118		
94453	26	Hast w/oxygen titrate		\$38		
94453	TC	Hast w/oxygen titrate		\$123		
94453		Hast w/oxygen titrate		\$162		
94610		Surfactant admin thru tube		\$125		
94620		Pulmonary stress test/simple		\$216		
94620	26	Pulmonary stress test/simple		\$109		
94620	TC	Pulmonary stress test/simple		\$107		
94621		Pulm stress test/ complex		\$216		
94621	26	Pulm stress test/ complex		\$109		
94621	TC	Pulm stress test/ complex		\$107		
94640		Airway inhalation treatment		\$30		
94642		Aerosol inhalation treatment		BR		
94644		Cbt 1st hour		\$92		
94645		Cbt each addl hour		\$29		
94660		Pos airway pressure, cpap		\$109		
94662		Neg pressure ventilation,cnp		\$77		
94664		Aerosol or vapor inhalations		\$39		
94665		Aerosol or vapor inhalations		\$37		
94668		Chest wall manipulation		\$26		
94680		Exhaled air analysis: o2		\$84		
94680	26	Exhaled air analysis: o2		\$44		
94680	TC	Exhaled air analysis: o2		\$40		
94681		Exhaled air analysis: o2,co2		\$147		
94681	26	Exhaled air analysis: o2,co2		\$45		
94681	TC	Exhaled air analysis: o2,co2		\$103		
94690		Exhaled air analysis		\$48		
94690	26	Exhaled air analysis		\$9		
94690	TC	Exhaled air analysis		\$40		
94726	26	Pulm funct tst plethysmograp		\$26		
94726	TC	Pulm funct tst plethysmograp		\$85		
94726		Pulm funct tst plethysmograp		\$111		
94727	26	Pulm function test by gas		\$26		
94727	TC	Pulm function test by gas		\$61		
94727		Pulm function test by gas		\$87		
94728	26	Pulm funct test oscillometry		\$26		
94728	TC	Pulm funct test oscillometry		\$61		
94728		Pulm funct test oscillometry		\$87		
94729	26	C02/membrane diffuse capacity		\$17		
94729	TC	C02/membrane diffuse capacity		\$93		
94729		C02/membrane diffuse capacity		\$110		
94750		Pulmonary compliance study		\$80		
94750	26	Pulmonary compliance study		\$38		
94750	TC	Pulmonary compliance study		\$42		

Title 40, Part I

CPT Code	Mod	Description	Global Days	Maximum Allowance	Non-Facility Maximum	Facility Maximum
94760		Measure blood oxygen level		\$19		
94761		Measure blood oxygen level		\$50		
94762		Measure blood oxygen level		\$84		
94770		Exhaled carbon dioxide test		\$50		
94770	26	Exhaled carbon dioxide test		\$24		
94770	TC	Exhaled carbon dioxide test		\$26		
94772		Breath recording, infant		BR		
94772	26	Breath recording, infant		BR		
94772	TC	Breath recording, infant		BR		
94780		Car seat/bed test 60 min			\$104	\$48
94781		Car seat/bed test + 30 min			\$41	\$17
94799		Pulmonary service/procedure		BR		
94799	26	Pulmonary service/procedure		BR		
94799	TC	Pulmonary service/procedure		BR		
95004		Allergy skin tests		\$7		
95010		Sensitivity skin tests		\$19		
95012		Exhaled nitric oxide meas		\$40		
95015		Sensitivity skin tests		\$19		
95024		Allergy skin tests		\$11		
95027		Skin end point titration		\$11		
95028		Allergy skin tests		\$17		
95044		Allergy patch tests		\$14		
95052		Photo patch test		\$18		
95056		Photosensitivity tests		\$13		
95060		Eye allergy tests		\$25		
95065		Nose allergy test		\$14		
95070		Bronchial allergy tests		\$155		
95071		Bronchial allergy tests		\$199		
95075		Ingestion challenge test		\$208		
95115		Immunotherapy, one injection	0	\$32		
95117		Immunotherapy injections	0	\$37		
95120		Immunotherapy, single antigen		BR		
95125		Immunotherapy, many antigen		BR		
95130		Immunotherapy, insect venom		BR		
95131		Immunotherapy, insect venoms		BR		
95132		Immunotherapy, insect venoms		BR		
95133		Immunotherapy, insect venoms		BR		
95134		Immunotherapy, insect venoms		BR		
95144		Antigen therapy services	0		\$26	\$7
95145		Antigen therapy services	0	\$32		
95146		Antigen therapy services	0	\$44		
95147		Antigen therapy services	0	\$62		
95148		Antigen therapy services	0	\$63		
95149		Antigen therapy services	0	\$78		
95165		Antigen therapy services	0	\$15		
95170		Antigen therapy services	0	\$20		
95180		Rapid desensitization	0	\$153		
95199		Allergy immunology services	0	BR		
95250		Glucose monitoring cont		\$329		
95251		Gluc monitor cont phys i&r		\$89		
95800	26	Slp stdy unattended		\$105		
95800	TC	Slp stdy unattended		\$227		
95800		Slp stdy unattended		\$332		
95801	26	Slp stdy unatnd w/anal		\$100		
95801	TC	Slp stdy unatnd w/anal		\$79		
95801		Slp stdy unatnd w/anal		\$179		
95803	26	Actigraphy testing		\$91		
95803	TC	Actigraphy testing		\$249		
95803		Actigraphy testing		\$340		
95805		Multiple sleep latency test		\$571		
95805	26	Multiple sleep latency test		\$178		
95805	TC	Multiple sleep latency test		\$392		
95806		Sleep study, unattended		\$650		
95806	26	Sleep study, unattended		\$276		
95806	TC	Sleep study, unattended		\$374		
95807		Sleep study, attended		\$738		

LABOR AND EMPLOYMENT

CPT Code	Mod	Description	Global Days	Maximum Allowance	Non-Facility Maximum	Facility Maximum
95807	26	Sleep study, attended		\$239		
95807	TC	Sleep study, attended		\$499		
95808		Polysomnography, 1-3		\$708		
95808	26	Polysomnography, 1-3		\$332		
95808	TC	Polysomnography, 1-3		\$377		
95810		Polysomnography, 4 or more		\$708		
95810	26	Polysomnography, 4 or more		\$332		
95810	TC	Polysomnography, 4 or more		\$377		
95811		Polysomnography w/cpap		\$967		
95811	26	Polysomnography w/cpap		\$444		
95811	TC	Polysomnography w/cpap		\$523		
95812		Electroencephalogram (EEG)		\$216		
95812	26	Electroencephalogram (EEG)		\$113		
95812	TC	Electroencephalogram (EEG)		\$102		
95813		Electroencephalogram (EEG)		\$261		
95813	26	Electroencephalogram (EEG)		\$159		
95813	TC	Electroencephalogram (EEG)		\$102		
95816		Electroencephalogram (EEG)		\$200		
95816	26	Electroencephalogram (EEG)		\$100		
95816	TC	Electroencephalogram (EEG)		\$100		
95819		Electroencephalogram (EEG)		\$216		
95819	26	Electroencephalogram (EEG)		\$113		
95819	TC	Electroencephalogram (EEG)		\$103		
95822		Sleep electroencephalogram		\$251		
95822	26	Sleep electroencephalogram		\$119		
95822	TC	Sleep electroencephalogram		\$132		
95824		Electroencephalography		\$127		
95824	26	Electroencephalography		\$97		
95824	TC	Electroencephalography		\$31		
95827		Night electroencephalogram		\$310		
95827	26	Night electroencephalogram		\$144		
95827	TC	Night electroencephalogram		\$166		
95829		Surgery electrocorticogram		\$485		
95829	26	Surgery electrocorticogram		\$474		
95829	TC	Surgery electrocorticogram		\$12		
95830		Insert electrodes for eeg		\$181		
95831		Limb muscle testing, manual		\$44		
95832		Hand muscle testing, manual		\$40		
95833		Body muscle testing, manual		\$64		
95834		Body muscle testing, manual		\$91		
95851		Range of motion measurements		\$38		
95852		Range of motion measurements		\$26		
95857		Tensilon test		\$77		
95860		Muscle test, one limb		\$147		
95860	26	Muscle test, one limb		\$119		
95860	TC	Muscle test, one limb		\$28		
95861		Muscle test, two limbs		\$253		
95861	26	Muscle test, two limbs		\$197		
95861	TC	Muscle test, two limbs		\$56		
95863		Muscle test, 3 limbs..		\$300		
95863	26	Muscle test, 3 limbs..		\$230		
95863	TC	Muscle test, 3 limbs..		\$70		
95864		Muscle test, 4 limbs..		\$394		
95864	26	Muscle test, 4 limbs..		\$260		
95864	TC	Muscle test, 4 limbs..		\$134		
95865	26	Muscle test larynx		\$168		
95865	TC	Muscle test larynx		\$96		
95865		Muscle test larynx		\$264		
95866	26	Muscle test hemidiaphragm		\$132		
95866	TC	Muscle test hemidiaphragm		\$109		
95866		Muscle test hemidiaphragm		\$241		
95867		Muscle test, head or neck		\$131		
95867	26	Muscle test, head or neck		\$89		
95867	TC	Muscle test, head or neck		\$42		
95868		Muscle test, head or neck		\$253		
95868	26	Muscle test, head or neck		\$203		

Title 40, Part I

CPT Code	Mod	Description	Global Days	Maximum Allowance	Non-Facility Maximum	Facility Maximum
95868	TC	Muscle test, head or neck		\$51		
95869		Muscle test, thor paraspinal		\$65		
95869	26	Muscle test, thor paraspinal		\$49		
95869	TC	Muscle test, thor paraspinal		\$17		
95870		Muscle test, nonparaspinal		\$65		
95870	26	Muscle test, nonparaspinal		\$49		
95870	TC	Muscle test, nonparaspinal		\$17		
95872		Muscle test, one fiber		\$203		
95872	26	Muscle test, one fiber		\$157		
95872	TC	Muscle test, one fiber		\$46		
95873	26	Guide nerv destr elec stim		\$41		
95873	TC	Guide nerv destr elec stim		\$107		
95873		Guide nerv destr elec stim		\$148		
95874	26	Guide nerv destr needle emg		\$40		
95874	TC	Guide nerv destr needle emg		\$102		
95874		Guide nerv destr needle emg		\$142		
95875		Limb exercise test		\$144		
95875	26	Limb exercise test		\$113		
95875	TC	Limb exercise test		\$31		
95885	26	Musc tst done w/nerv tst lim		\$37		
95885	TC	Musc tst done w/nerv tst lim		\$78		
95885		Musc tst done w/nerv tst lim		\$115		
95886	26	Musc test done w/n test comp		\$98		
95886	TC	Musc test done w/n test comp		\$82		
95886		Musc test done w/n test comp		\$181		
95887	26	Musc tst done w/n tst nonext		\$77		
95887	TC	Musc tst done w/n tst nonext		\$84		
95887		Musc tst done w/n tst nonext		\$161		
95900		Motor nerve conduction test		\$75		
95900	26	Motor nerve conduction test		\$54		
95900	TC	Motor nerve conduction test		\$21		
95903		Motor nerve conduction test		\$87		
95903	26	Motor nerve conduction test		\$68		
95903	TC	Motor nerve conduction test		\$19		
95904		Sense/mixed n conduction test		\$64		
95904	26	Sense/mixed n conduction test		\$47		
95904	TC	Sense/mixed n conduction test		\$17		
95905	26	Motor/sens nrve conduct test		\$6		
95905	TC	Motor/sens nrve conduct test		\$133		
95905		Motor/sens nrve conduct test		\$138		
95920		Intraop nerve test add on		\$348		
95920	26	Intraop nerve test add on		\$250		
95920	TC	Intraop nerve test add on		\$97		
95921		Autonomic nerv function test		\$117		
95921	26	Autonomic nerv function test		\$89		
95921	TC	Autonomic nerv function test		\$28		
95922		Autonomic nerv function test		\$123		
95922	26	Autonomic nerv function test		\$94		
95922	TC	Autonomic nerv function test		\$28		
95923		Autonomic nerv function test		\$117		
95923	26	Autonomic nerv function test		\$89		
95923	TC	Autonomic nerv function test		\$28		
95925		Somatosensory testing		\$148		
95925	26	Somatosensory testing		\$80		
95925	TC	Somatosensory testing		\$68		
95926		Somatosensory testing		\$149		
95926	26	Somatosensory testing		\$81		
95926	TC	Somatosensory testing		\$68		
95927		Somatosensory testing		\$149		
95927	26	Somatosensory testing		\$81		
95927	TC	Somatosensory testing.		\$68		
95928	26	C motor evoked uppr limbs		\$159		
95928	TC	C motor evoked uppr limbs		\$399		
95928		C motor evoked uppr limbs		\$558		
95929	26	C motor evoked lwr limbs		\$159		
95929	TC	C motor evoked lwr limbs		\$403		

LABOR AND EMPLOYMENT

CPT Code	Mod	Description	Global Days	Maximum Allowance	Non-Facility Maximum	Facility Maximum
95929		C motor evoked lwr limbs		\$562		
95930		Visual evoked potential test		\$81		
95930	26	Visual evoked potential test		\$62		
95930	TC	Visual evoked potential test		\$19		
95933		Blink reflex test		\$138		
95933	26	Blink reflex test		\$81		
95933	TC	Blink reflex test		\$58		
95934		H-reflex test.....		\$77		
95934	26	H-reflex test.....		\$60		
95934	TC	H-reflex test.....		\$17		
95936		H-reflex test.....		\$80		
95936	26	H-reflex test.....		\$63		
95936	TC	H-reflex test.....		\$17		
95937		Neuromuscular junction test		\$102		
95937	26	Neuromuscular junction test		\$77		
95937	TC	Neuromuscular junction test		\$25		
95938	26	Somatosensory testing		\$91		
95938	TC	Somatosensory testing		\$517		
95938		Somatosensory testing		\$608		
95939	26	C motor evoked upr&lwr limbs		\$239		
95939	TC	C motor evoked upr&lwr limbs		\$714		
95939		C motor evoked upr&lwr limbs		\$952		
95950		Ambulatory EEG monitoring		\$670		
95950	26	Ambulatory EEG monitoring		\$190		
95950	TC	Ambulatory EEG monitoring		\$480		
95951		EEG monitoring/videorecord		\$1,131		
95951	26	EEG monitoring/videorecord		\$553		
95951	TC	EEG monitoring/videorecord		\$578		
95953		EEG monitoring/computer		\$774		
95953	26	EEG monitoring/computer		\$311		
95953	TC	EEG monitoring/computer		\$464		
95954		EEG monitoring/giving drugs		\$344		
95954	26	EEG monitoring/giving drugs		\$306		
95954	TC	EEG monitoring/giving drugs		\$37		
95955		EEG during surgery		\$298		
95955	26	EEG during surgery		\$152		
95955	TC	EEG during surgery		\$146		
95956		EEG monitoring/cable/radio		\$796		
95956	26	EEG monitoring/cable/radio		\$332		
95956	TC	EEG monitoring/cable/radio		\$464		
95957		EEG digital analysis..		\$319		
95957	26	EEG digital analysis..		\$191		
95957	TC	EEG digital analysis..		\$128		
95958		EEG monitoring/function test		\$684		
95958	26	EEG monitoring/function test		\$557		
95958	TC	EEG monitoring/function test		\$128		
95961		Electrode stimulation, brain		\$414		
95961	26	Electrode stimulation, brain		\$317		
95961	TC	Electrode stimulation, brain		\$97		
95962		Electrode stim, brain add-on		\$432		
95962	26	Electrode stim, brain add-on		\$334		
95962	TC	Electrode stim, brain add-on		\$97		
95965		Meg spontaneous		\$862		
95966		Meg evoked single		\$430		
95967		Meg evoked each addl		\$377		
95970		Analyze neurostim, no prog		\$47		
95971		Analyze neurostim, simple		\$76		
95972		Analyze neurostim,complex		\$140		
95973		Analyze neurostim,complex		\$89		
95974		Cranial neurostim, complex		\$283		
95975		Cranial neurostim, complex		\$169		
95978		Analyze neurostim brain/1h			\$488	\$381
95979		Analyz neurostim brain addon			\$210	\$175
95980		Io anal gast n-stim init		\$96		
95981		Io anal gast n-stim subsq			\$67	\$36
95982		Io ga n-stim subsq w/reprog			\$108	\$73



Title 40, Part I

CPT Code	Mod	Description	Global Days	Maximum Allowance	Non-Facility Maximum	Facility Maximum
95990		Spin/brain pump refill & main		\$188		
95991		Spin/brain pump refill & main			\$254	\$82
95992		Canalith repositioning proc			\$87	\$77
95999		Neurological procedure		BR		
96000		Motion analysis video/3d		\$204		
96001		Motion test w/ft press meas		\$203		
96002		Dynamic surface emg		\$44		
96003		Dynamic fine wire emg		\$40		
96004		Phys review of motion tests		\$232		
96020		Functional brain mapping		\$350		
96040		Genetic counseling 30 min		\$94		
96101		Psycho testing by psych/phys		\$169		
96102		Psycho testing by technician		\$165		
96103		Psycho testing admin by comp		\$139		
96105		Assessment Aphasia W/Interp & Report Per Hour		BR		
96110		Developmental screen		\$20		
96116		Neurobehavioral status exam		\$184		
96118		Neuropsych tst by psych/phys		\$184		
96119		Neuropsych testing by tec		\$140		
96120		Neuropsych tst admin w/comp		\$190		
96125		Cognitive test by hc pro		\$210		
96150		Assess hlth/behave init		\$41		
96151		Assess hlth/behave subseq		\$40		
96152		Intervene hlth/behave indiv		\$38		
96153		Intervene hlth/behave group		\$9		
96154		Interv hlth/behav fam w/pt		\$37		
96155		Interv hlth/behav fam no pt		\$46		
96156		Health Behavior Assessment/Re-Assessment		BR		
96157		Health Behavior Ivntj Indiv F2f 1st 30 Min		BR		
96158		Health Behavior Ivntj Indiv F2f Ea Addl 15 Min		BR		
96360		Hydration iv infusion init		\$114		
96361		Hydrate iv infusion add-on		\$30		
96365		Ther/proph/diag iv inf init		\$146		
96366		Ther/proph/diag iv inf addon		\$44		
96367		Tx/proph/dg addl seq iv inf		\$63		
96368		Ther/diag concurrent inf		\$38		
96369		Sc ther infusion up to 1 hr		\$395		
96370		Sc ther infusion addl hr		\$32		
96371		Sc ther infusion reset pump		\$177		
96372		Ther/proph/diag inj sc/im		\$50		
96373		Ther/proph/diag inj ia		\$41		
96374		Ther/proph/diag inj iv push		\$111		
96375		Tx/pro/dx inj new drug addon		\$44		
96401		Chemo anti-neopl sq/im		\$147		
96402		Chemo hormon antineopl sq/im		\$64		
96405		Intralesional chemo admin	0	\$66		
96406		Intralesional chemo admin	0	\$100		
96409		Chemo iv push sngl drug		\$217		
96411		Chemo iv push addl drug		\$122		
96413		Chemo iv infusion 1 hr		\$265		
96415		Chemo iv infusion addl hr		\$60		
96416		Chemo prolong infuse w/pump		\$253		
96417		Chemo iv infus each addl seq		\$138		
96420		Chemotherapy, push technique		\$91		
96422		Chemotherapy,infusion method		\$89		
96423		Chemo, infuse method add-on		\$36		
96425		Chemotherapy, infusion		\$103		
96440		Chemotherapy, intracavitary	0	\$230		
96446		Chemotx admn prtl cavity		\$395		
96521		Refill/maint portable pump		\$274		
96522		Refill/maint pump/resvr syst		\$219		
96523		Irrig drug delivery device		\$49		
96542		Chemotherapy injection		\$187		
96549		Chemotherapy, unspecified		BR		
96567		Photodynamic tx skin		\$281		

LABOR AND EMPLOYMENT

CPT Code	Mod	Description	Global Days	Maximum Allowance	Non-Facility Maximum	Facility Maximum
96570		Photodynamic tx, 30 min		\$118		
96571		Photodynamic tx, addl 15 min		\$54		
96900		Ultraviolet light therapy		\$29		
96902		Trichogram.....		\$50		
96904		Whole body photography		\$144		
96910		Photochemotherapy with uv-b		\$42		
96912		Photochemotherapy with uv-a		\$49		
96913		Photochemotherapy, uv-a or b		\$266		
96920		Laser tx skin < 250 sq cm		\$360		
96921		Laser tx skin 250-500 sq cm		\$370		
96922		Laser tx skin > 500 sq cm		\$515		
96999		Dermatological procedure		BR		
97001		Pt evaluation.....		\$117		
97002		Pt re-evaluation.....		\$49		
97003		Ot evaluation.....		\$120		
97004		Ot re-evaluation.....		\$50		
97010		Hot or cold packs therapy		\$19		
97012		Mechanical traction therapy		\$30		
97014		Electric stimulation therapy		\$30		
97016		Vasopneumatic device therapy		\$35		
97018		Paraffin bath therapy		\$36		
97022		Whirlpool therapy		\$29		
97024		Diathermy treatment		\$28		
97026		Infrared therapy		\$30		
97028		Ultraviolet therapy		\$26		
97032		Electrical stimulation		\$28		
97033		Electric current therapy		\$29		
97034		Contrast bath therapy		\$22		
97035		Ultrasound therapy		\$23		
97036		Hydrotherapy		\$43		
97039		Physical therapy treatment		\$31		
97110		Therapeutic exercises		\$43		
97112		Neuromuscular reeducation		\$42		
97113		Aquatic therapy/exercises		\$46		
97116		Gait training therapy		\$38		
97124		Massage therapy.....		\$34		
97129		Ther IVNTJ Cog Funcj CNTCT 1ST 15 Minutes		BR		
97130		Ther IVNTJ Cog Funcj CNTCT EA Addl 15 Minutes		BR		
97139		Physical medicine procedure		\$27		
97140		Manual therapy.....		\$44		
97150		Group therapeutic procedures		\$34		
97161		Physical Therapy Evaluation Low Complex 20 Mins		BR		
97162		Physical Therapy Evaluation Mod Complex 30 Mins		BR		
97163		Physical Therapy Evaluation High Complex 45 Mins		BR		
97164		Physical Therapy Re-Eval Est Plan Care 20 Mins		BR		
97165		Occupational Therapy Eval Low Complex 30 Mins		BR		
97166		Occupational Therapy Eval Mod Complex 45 Mins		BR		
97167		Occupational Therapy Eval High Complex 60 Mins		BR		
97168		Occupational Ther Re-Eval Est Plan Care 30 Mins		BR		
97530		Therapeutic activities		\$44		
97532		Cognitive skills development		\$54		
97533		Sensory integration		\$59		
97535		Self care mngmt training		\$45		
97537		Community/work reintegration		\$45		
97542		Wheelchair mngment v		\$31		
97545		Work hardening, initial 2 hours		\$88		
97546		Work hardening add-on, each additional 60		\$44		

Title 40, Part I

CPT Code	Mod	Description	Global Days	Maximum Allowance	Non-Facility Maximum	Facility Maximum
		minutes, up to 6 additional hours				
97597		Rmvl devital tis 20 cm<		\$155		
97598		Rmvl devital tis addl 20 cm<		\$51		
97605		Neg press wound tx < 50 cm		\$86		
97606		Neg press wound tx > 50 cm		\$92		
97750		Physical performance test		\$50		
97755		Assistive technology assessment (e.g., to restore, augment or compensate for existing function, optimize functional tasks and/or maximize environmental accessibility), direct one-on-one contact by provider, with written report, each 15 minutes		\$39		
97760		Orthotic(s) management and training (including assessment and fitting when not otherwise reported), upper extremity(s), lower extremity(s) and/or trunk, each 15 minutes		\$39		
97761		Prosthetic training, upper and/or lower extremity(s), each 15 minutes		\$35		
97762		Checkout for orthotic/prosthetic use, established patient, each 15 minutes		\$68		
97799		Physical medicine procedure		\$43		
97802		Medical nutrition indiv in		\$73		
97803		Med nutrition indiv subseq		\$63		
97804		Medical nutrition group		\$32		
97810		Acupunct w/o stimul 15 min		\$73		
97811		Acupunct w/o stimul addl 15m		\$55		
97813		Acupunct w/stimul 15 min		\$78		
97814		Acupunct w/stimul addl 15m		\$64		
98925		Osteopathic manipulation	0	\$51		
98926		Osteopathic manipulation	0	\$77		
98927		Osteopathic manipulation	0	\$91		
98928		Osteopathic manipulation	0	\$105		
98929		Osteopathic manipulation	0	\$114		
98940		Chiropractic manipulation	0	\$52		
98941		Chiropractic manipulation	0	\$68		
98942		Chiropractic manipulation	0	\$84		
98943		Chiropractic manipulation		\$50		
98960		Self-mgmt educ & train 1 pt		\$55		
98961		Self-mgmt educ/train 2-4 pt		\$27		
98962		Self-mgmt educ/train 5-8 pt		\$20		
98966		Hc pro phone call 5-10 min			\$28	\$25
98967		Hc pro phone call 11-20 min			\$54	\$51
98968		Hc pro phone call 21-30 min			\$80	\$77
98970		QNHP Ol Digital ASSMT&MGMT Est Pt <7 D 5-10 Min		\$25		
98971		QNHP OL Digital Assmt and Mgmt Est PT <7 D 11-20 MIN		\$65		
98972		QNHP OL Digital Assmt and Mgmt Est PT <7 D 21+ MIN		\$150		
99000		Specimen handling		BR		
99001		Specimen handling		BR		
99002		Device handling		BR		
99024		Post-op follow-up visit		BR		
99050		Medical services, after hours		BR		
99056		Non-office medical services		BR		
99058		Office emergency care		BR		
99070		Special supplies		BR		
99071		Patient education materials		BR		
99075		Medical testimony		BR		
99078		Group health education		BR		
99080		Special reports or forms		BR		
99082		Unusual physician travel		BR		
99090		Computer data analysis		BR		
99091		Collect/review data from pt		\$115		
99100		Special anesthesia service.		BR		
99116		Anesthesia with hypothermia		BR		
99135		Special anesthesia procedure		BR		

LABOR AND EMPLOYMENT

CPT Code	Mod	Description	Global Days	Maximum Allowance	Non-Facility Maximum	Facility Maximum
99140		Emergency anesthesia..		\$35		
99143		Mod cs by same phys < 5 yrs		BR		
99144		Mod cs by same phys 5 yrs +		BR		
99145		Mod cs by same phys add-on		BR		
99148		Mod cs diff phys < 5 yrs		BR		
99149		Mod cs diff phys 5 yrs +		BR		
99150		Mod cs diff phys add-on		BR		
99170		Anogenital exam, child	0		\$263	\$178
99173		Visual screening test		\$6		
99174		Ocular photoscreening		\$59		
99175		Induction of vomiting		\$101		
99183		Hyperbaric oxygen therapy		\$292		
99190		Special pump services		BR		
99191		Special pump services		BR		
99192		Special pump services		BR		
99195		Phlebotomy		\$32		
99199		Special service/proc/ report		BR		
99201		Office/outpatient visit, new		\$56		
99202		Office/outpatient visit, new		\$89		
99203		Office/outpatient visit, new		\$122		
99204		Office/outpatient visit, new		\$182		
99205		Office/outpatient visit, new		\$229		
99211		Office/outpatient visit, est		\$27		
99212		Office/outpatient visit, est		\$48		
99213		Office/outpatient visit, est		\$68		
99214		Office/outpatient visit, est		\$105		
99215		Office/outpatient visit, est		\$166		
99217		Observation care discharge.		\$131		
99218		Observation care		\$129		
99219		Observation care		\$205		
99220		Observation care		\$258		
99221		Initial hospital care		\$127		
99222		Initial hospital care		\$210		
99223		Initial hospital care		\$268		
99224		Subsequent observation care		\$81		
99225		Subsequent observation care		\$146		
99226		Subsequent observation care		\$210		
99231		Subsequent hospital care		\$66		
99232		Subsequent hospital care		\$97		
99233		Subsequent hospital care		\$135		
99234		Observ/hosp same date		\$240		
99235		Observ/hosp same date		\$327		
99236		Observ/hosp same date		\$398		
99238		Hospital discharge day		\$131		
99239		Hospital discharge day		\$166		
99241		Office consultation		\$90		
99242		Office consultation...		\$161		
99243		Office consultation		\$180		
99244		Office consultation		\$252		
99245		Office consultation		\$341		
99251		Initial inpatient consult		\$92		
99252		Initial inpatient consult		\$140		
99253		Initial inpatient consult		\$185		
99254		Initial inpatient consult		\$254		
99255		Initial inpatient consult		\$343		
99274		Confirmatory consultation		\$217		
99275		Confirmatory consultation		\$299		
99281		Emergency dept visit		\$40		
99282		Emergency dept visit		\$63		
99283		Emergency dept visit		\$114		
99284		Emergency dept visit		\$173		
99285		Emergency dept visit..		\$296		
99288		Direct advanced life support		BR		
99291		Critical care, first hour		\$392		
99292		Critical care, addl 30 min		\$191		
99295		Neonatal critical care		\$896		

Title 40, Part I

CPT Code	Mod	Description	Global Days	Maximum Allowance	Non-Facility Maximum	Facility Maximum
99296		Neonatal critical care		\$821		
99297		Neonatal critical care		\$445		
99298		Neonatal critical care		\$281		
99301		Nursing facility care		\$121		
99302		Nursing facility care		\$156		
99303		Nursing facility care		\$213		
99304		Nursing facility care init		\$190		
99305		Nursing facility care init		\$270		
99306		Nursing facility care init		\$342		
99307		Nursing fac care subseq		\$90		
99308		Nursing fac care subseq		\$140		
99309		Nursing fac care subseq		\$184		
99310		Nursing fac care subseq		\$273		
99311		Nursing fac care, subseq		\$68		
99312		Nursing fac care, subseq		\$102		
99313		Nursing fac care, subseq		\$138		
99315		Nursing fac discharge day		\$120		
99316		Nursing fac discharge day		\$148		
99318		Annual nursing fac assessmnt		\$195		
99321		Rest home visit, new patient		\$79		
99322		Rest home visit, new patient		\$112		
99323		Rest home visit, new patient		\$147		
99324		Domicil/r-home visit new pat		\$114		
99325		Domicil/r-home visit new pat		\$163		
99326		Domicil/r-home visit new pat		\$284		
99327		Domicil/r-home visit new pat		\$378		
99328		Domicil/r-home visit new pat		\$438		
99331		Rest home visit, estab pat		\$64		
99332		Rest home visit, estab pat		\$84		
99333		Rest home visit, estab pat		\$103		
99334		Domicil/r-home visit est pat		\$123		
99335		Domicil/r-home visit est pat		\$192		
99336		Domicil/r-home visit est pat		\$273		
99337		Domicil/r-home visit est pat		\$392		
99339		Domicil/r-home care supervis		\$157		
99340		Domicil/r-home care supervis		\$220		
99341		Home visit, new patient		\$112		
99342		Home visit, new patient		\$156		
99343		Home visit, new patient		\$225		
99344		Home visit, new patient		\$289		
99345		Home visit, new patient		\$346		
99347		Home visit, est. patient		\$88		
99348		Home visit, est patient		\$131		
99349		Home visit, est patient		\$194		
99350		Home visit, est patient		\$280		
99354		Prolonged service, office		\$190		
99355		Prolonged service, office		\$187		
99356		Prolonged service, inpatient		\$182		
99357		Prolonged service, inpatient		\$183		
99358		Prolonged serv, w/o contact		\$190		
99359		Prolonged serv, w/o contact		\$187		
99360		Physician standby services		\$127		
99361		Physician/team conference		BR		
99362		Physician/team conference		BR		
99363		Anticoag mgmt init			\$255	\$170
99364		Anticoag mgmt subseq			\$87	\$65
99366		Team conf w/pat by hc pro			\$86	\$84
99367		Team conf w/o pat by phys		\$115		
99368		Team conf w/o pat by hc pro		\$74		
99371		Physician phone consultation		BR		
99372		Physician phone consultation		BR		
99373		Physician phone consultation		BR		
99374		Home health care		\$125		
99375		Home health care supervision		\$171		
99377		Hospice care supervision		\$125		
99378		Hospice care supervision		\$172		

LABOR AND EMPLOYMENT

CPT Code	Mod	Description	Global Days	Maximum Allowance	Non-Facility Maximum	Facility Maximum
99379		Nursing fac care supervision		\$125		
99380		Nursing fac care supervision		\$174		
99381		Prev visit, new, infant		\$175		
99382		Preventive visit, new, age 1-4			\$231	\$164
99383		Preventive visit, new, age 5-11			\$241	\$174
99384		Preventive visit,new,12-17			\$272	\$206
99385		Preventive visit,new,18-39			\$264	\$198
99386		Preventive visit,new,40-64			\$306	\$240
99387		Preventive visit, new, 65&over			\$332	\$258
99391		Prev visit, est, infant		\$147		
99392		Preventive visit,est,age 1-4			\$213	\$155
99393		Preventive visit,est,age5-11			\$212	\$155
99394		Preventive visit,est,12-17			\$232	\$174
99395		Preventive visit,est,18-39			\$237	\$179
99396		Preventive visit,est,40-64		\$255		
99397		Preventive visit, est, 65&over			\$273	\$206
99401		Preventive counseling,		\$68		
99402		Preventive counseling, indiv			\$124	\$101
99403		Preventive counseling, indiv			\$174	\$150
99404		Preventive counseling, indiv			\$224	\$200
99406		Behav chng smoking 3-10 min			\$28	\$25
99407		Behav chng smoking > 10 min			\$55	\$52
99408		Audit/dast 15-30 min			\$71	\$66
99409		Audit/dast over 30 min			\$137	\$134
99411		Preventive counseling, group		\$22		
99412		Preventive counseling, group			\$43	\$25
99420		Health risk assessment test		\$22		
99421		Online Digital E/M SVC Est Pt <7 D 5-10 Minutes			\$31	\$27
99422		Online Digital E/M SVC Est Pt <7 D 11-20 Minutes			\$62	\$55
99423		Online Digital E/M SVC Est Pt <7 D 21+ Minutes			\$100	\$87
99429		Unlisted preventive service		BR		
99431		Initial care, normal newborn		BR		
99432		Newborn care not in hospital		BR		
99433		Normal newborn care, hospital		BR		
99435		Newborn discharge day hosp		\$207		
99436		Attendance, birth.....		\$209		
99440		Newborn resuscitation		\$455		
99441		Phone e/m by phys 5-10 min			\$28	\$25
99442		Phone e/m by phys 11-20 min			\$54	\$51
99443		Phone e/m by phys 21-30 min			\$80	\$77
99444		Online e/m by phys		\$72		
99450		Life/disability evaluation		BR		
99455		Disability examination		BR		
99456		Disability examination		BR		
99460		Init nb em per day hosp		\$201		
99461		Init nb em per day non-fac		\$198		
99462		Sbsq nb em per day hosp		\$89		
99463		Same day nb discharge		\$237		
99464		Attendance at delivery		\$150		
99465		Nb resuscitation		\$299		
99466		Ped crit care transport		\$556		
99467		Ped crit care transport addl		\$249		
99468		Neonate crit care initial		\$1,890		
99469		Neonate crit care subsq		\$859		
99471		Ped critical care initial		\$1,607		
99472		Ped critical care subsq		\$820		
99475		Ped crit care age 2-5 init		\$1,148		
99476		Ped crit care age 2-5 subsq		\$699		
99477		Init day hosp neonate care		\$703		
99478		Ic lbw inf < 1500 gm subsq		\$278		
99479		Ic lbw inf 1500-2500 g subsq		\$260		
99480		Ic inf pbw 2501-5000 g subsq		\$244		
99495		Transitional Care Mange Srvc 14 Day		BR		

CPT Code	Mod	Description	Global Days	Maximum Allowance	Non-Facility Maximum	Facility Maximum
		Discharge				
99496		Transitional Care Mange Srvc 7 Day Discharge		BR		
99499		Unlisted e/m service		BR		

C. Table 3

Code	Mod	Description	Global Days	Maximum Allowance	Non-Facility Maximum	Facility Maximum
C9803		COVID-19 Specimen Collection HOPD		BR		
G2010		Remot Image Submit By PT		\$24		
G2012		Brief Check In By MD/QHP		\$27		
G2023		Specimen Collect COVID-19		\$47		
G2024		Spec Coll SNF/Lab COVID-19		\$51		
G2061		Qual NonMD Est PT 5-10M		\$25		
G2062		Qual NonMD Est PT 11-20M		\$43		
G2063		Qual NonMD Est PT 21>Min		\$68		
U0001		2019-NCOV Diagnostic P		\$72		
U0002		COVID-19 Lab Test Non-CDC		\$103		
U0003		SARS-COV-2 COVID-19 Amp Prb Htt		\$200		
U0004		COVID-19 Lab Test Non-CDC Htt		\$200		

AUTHORITY NOTE: Promulgated in accordance with R.S. 23:1034.2.

HISTORICAL NOTE: Promulgated by the Department of Labor, Office of Workers' Compensation, LR 19:54 (January 1993), repromulgated LR 19:212 (February 1993), amended LR 20:1299 (November 1994), LR 27:314 (March 2001), amended by the Workforce Commission, Office of Workers' Compensation, LR 39:1854 (July 2013), LR 40:379 (February 2014), amended by the Workforce Commission, Office of Workers' Compensation Administration, LR 42:1696 (October 2016), LR 46:1401 (October 2020).

## Chapter 53. Dental Care Services, Reimbursement Schedule and Billing Instructions

Editor's Note: Other Sections applying to this Chapter can be found in Chapter 51.

### §5313. Billing Instructions

A. The American Dental Association (ADA) claim form is to be used for billing services provided to workers'

compensation employer claimants. Do not use any other form.

B. Partial bills should not be filed by the provider or the claimant. An invoice for the full amount must be filed by one of the two parties. If the claimant pays for medical or other services which are determined to be compensable expenses, it is his responsibility to file the ADA dental claim form, with the workers' compensation carrier/self-insured employer to receive reimbursement.

C. This is not the case if the provider agrees to file for the claimant; the carrier will pay directly to the provider and the provider must refund any partial payments made by the claimant directly to the claimant.

D. Please read the instructions carefully before completing the form. Failure to provide the information requested in a readable form will result in delay of payment.

E. A sample ADA dental claim form and detailed instructions for the proper completion of the form follows.

LABOR AND EMPLOYMENT

Sample ADA Form

Dentist's pre-treatment estimate  
 Dentist's statement of actual services

1 Patient name: First, last, initial  
 2 Relationship to employee:  self  child  spouse  other  
 3 Sex:  M  F  
 4 Patient birthdate: MM DD YYYY  
 5 If full-time student:  yes  no

6 Employee/subscriber name and mailing address  
 7 Employee/subscriber soc. sec. or I.D. number  
 8 Employee/subscriber birthdate: MM DD YYYY  
 9 Employer company name and address  
 10 Group number

11 Is patient covered by another dental plan?  yes  no  
 12 a Name and address of carrier(s)  
 b Is patient covered by a medical plan?  yes  no  
 13 a Name and address of other employer(s)  
 14 a Employee/subscriber name of different than patient's  
 14 b Employee/subscriber soc. sec. or I.D. number  
 14 c Employee/subscriber birthdate: MM DD YYYY  
 15 Relationship to patient:  self  parent  spouse  other

I have reviewed the following treatment plan. I authorize release of any information relating to this claim. I understand that I am responsible for all costs of dental treatment.  
 Signed (Patient or parent if minor) \_\_\_\_\_ Date \_\_\_\_\_  
 I hereby authorize payment of the dental benefits otherwise payable to me directly to the below named dental entity.  
 Signed (Insured person) \_\_\_\_\_ Date \_\_\_\_\_

16 Name of Being Dental or Dental Entity  
 17 Address where payment should be remitted: City, State, Zip  
 18 Dental Soc. Sec. or P.F.N.  
 19 Dental license no.  
 20 Dental phone no.  
 21 Is procedure in the oral diagnosis?  
 22 Is treatment for orthodontics?  
 23 Is treatment for orthodontics?  
 24 Is treatment result of occupational illness or injury?  
 25 Is treatment result of auto accident?  
 26 Other accident  
 27 Reason for replacement:  no  yes  
 28 Date of prior treatment

29 Fee with date current series  
 30 Price of treatment: Office, Hosp., EOP, Other  
 31 Restorative or mobile enclosed?  No  Yes How many?  
 32 Examination and treatment plan — List in order from tooth no. 1 through tooth no. 32 — Use charting system shown

Tooth	Surface	Description of service (including x-rays, prophylaxis, materials used, etc.)	Date service performed			Procedure number	Fee	# for administrative use only
			Mo.	Day	Year			
1								
2								
3								
4								
5								
6								
7								
8								
9								
10								
11								
12								
13								
14								
15								
16								
17								
18								
19								
20								
21								
22								
23								
24								
25								
26								
27								
28								
29								
30								
31								
32								

31 Remarks for unusual services

I hereby certify that the procedures as indicated by date have been completed and that the fees submitted are the actual fees I have charged and intend to collect for these procedures.  
 Signed (Dentist/ Dental) \_\_\_\_\_ Licensed holder \_\_\_\_\_ Date \_\_\_\_\_

**American Dental Association, 1990**  
 J-12

Total Fee Charged	
Max. Allowable	
Deductible	
Carrier %	
Carrier pays	
Patient pays	

F. Item-by-Item Instructions for Completion of the ADA Dental Claim Form. This Section is intended to serve as an instructional guide for completing the ADA dental insurance claim form. All applicable information should be completed in full.

<b>Dentist's Pretreatment Estimate, or Statement of Actual Services:</b> Check the appropriate box to indicate if the form is being used for an estimate and authorization, or if the form represents a statement of actual services.	
<b>Carrier Name and Address:</b> Enter the name and address of the carrier where the claim is to be sent.	
Item 1	<b>Patient's Name</b> —enter the patient's first name, middle initial and last name.
Item 2	<b>Relationship to Employee</b> —"Self" is the claimant. (Workers' compensation claims should always show "self".) Put an "X" in the appropriate box.
Item 3	<b>Sex</b> —put an "X" in the appropriate box; male or female.
Item 4	<b>Patient Birthdate</b> —enter the patient's date of birth, month, day and year.
Item 5	<b>If Full-Time Student</b> —leave blank.
Item 6	<b>Employee/Subscriber Name and Address</b> —same as patient's name and address.
Item 7	<b>Employee/Subscriber Social Security or I.D. Number</b> —if the patient has other insurance, show the insured's policy number.

Item 8	<b>Employee/Subscriber Birthday</b> —same as patient's birthday.
Item 9	<b>Employer (Company name and address)</b> —enter the employer's (company's) name and address.
Item 10	<b>Group Number</b> —if the patient has other insurance, show the insured's group number.
Item 11	<b>Is Patient Covered By Another Dental Plan?</b> Leave blank.
Item 12a	<b>Name and Address of Carrier</b> —Leave blank.
Item 12b	<b>Group Number</b> —Leave blank.
Item 13	<b>Name and Address of Other Employer(s)</b> Leave blank.
Item 14a	<b>Employee/Subscriber Name (If Different Than Patient's)</b> Leave blank.
Item 14b	<b>Employee/Subscriber Social Security Or I.D. Number</b> —Leave blank.
Item 14c	<b>Employee/Subscriber Birth Date</b> —Leave blank.
Item 15	<b>Relationship to Patient</b> —Leave blank.
<b>Patient Signature</b> —Have the patient or his authorized representative sign and date this block unless the signature is on file. If the patient's representative signs, the relationship to the patient must be indicated. The patient's signature authorizes release of medical information necessary to process the claim. It also authorizes payment of benefits to the physician or supplier.	
<b>Signature by Mark</b> —Where an illiterate or physically handicapped person signs by mark (X), a witness must enter his/her name and address next to the mark.	
<b>Insured Person's Signature Block</b> —The signature in this block authorizes payment to the physician or supplier.	



Item 16	<b>Name of Billing Dentist or Entity</b> —Enter the individual dentist's name or the name of the group/practice corporation responsible for the billing. This may differ from the actual treating dentist's name. This is the name that should appear on any payments or correspondence that will be remitted to the billing dentist.
Item 17	<b>Address Where Payment Should Be Remitted</b> —Enter the address of the billing dentist or entity in Item 16.
Item 18	<b>Dentist's Social Security Number or T.I.N.</b> —Show your physician/supplier federal tax I.D. (Employer Identification Number) or Social Security number.
Item 19	<b>Dentist's License Number</b> —Enter the license number of the billing dentist. This may differ from that of the treating dentist, which appears in the dentist's signature block at the bottom of the form.
Item 20	<b>Dentist's Phone Number</b> —Enter the dentist's area code and phone number.
Item 21	<b>First Visit Date Current Series</b> —Enter the date of the first visit in the current series of treatment.
Item 22	<b>Place of Treatment</b> —Enter the appropriate place of service code from the list provided.
<b>Place of Service Codes and Definitions</b>	
<b>Codes</b>	<b>Definitions</b>
00-10	<b>Unassigned</b>
11	<b>Office</b> —Location, other than a hospital, skilled nursing facility (SNF), military treatment facility. Community health facility, state or local public health clinics or intermediate care facility (ICF), where the health professional routinely provides health examinations, diagnosis and treatment of illness or injury on an ambulatory basis.
12	<b>Patient's Home</b> —Location, other than a hospital or other facility, where the patient receives care in a private residence.
13-20	<b>Unassigned</b>
21	<b>Inpatient Hospital</b> —A facility, other than psychiatric, which primarily provides diagnostic therapeutic (both surgical and nonsurgical) and rehabilitation services, or under the supervision of physicians to patients admitted for a variety of medical conditions.
22	<b>Outpatient Hospital</b> —A portion of a hospital which provides diagnostic, therapeutic (both surgical or nonsurgical) and rehabilitation services to sick or injured persons who do not require hospitalization or institutionalization.
23	<b>Emergency Room—Hospital</b> —A portion of a hospital where emergency diagnosis and treatment of illness or injury is provided.
24	<b>Ambulatory Surgical Center</b> —A freestanding facility, other than a physician's office, where surgical and diagnostic services are provided on an ambulatory basis.
25	<b>Birth Center</b> —A facility, other than a hospital's maternity facility or a physician's office, which provides a setting for labor, delivery and immediate post-partum care as well as immediate care of newborn infants.
26	<b>Military Treatment Facility</b> —A medical facility operated by one or more of the uniformed services. Military treatment facility (MTF) also refers to certain former U.S. Public Health Services (USPHS) facilities now designated as uniformed service treatment facilities (USTF).
27-30	<b>Unassigned</b>
31	<b>Skilled Nursing Facility</b> —A facility which primarily provides inpatient skilled nursing care and related services to patients who require medical, nursing or rehabilitative services but does not provide the level of care or treatment available in a hospital.
32	<b>Nursing Facility</b> —A facility which primarily provides to residents skilled nursing care and related services for the rehabilitation of injured, disabled or sick persons, or, on a regular basis, health related care services above the level of custodial care to other than mentally retarded individuals.

33	<b>Custodial Care Facility</b> —A facility which provides room, board and other personal assistance services, generally on a long-term basis, and which does not include a medical component.
34	<b>Hospice</b> —A facility, other than a patient's home, in which palliative and supportive care for terminally ill patients and their families are provided.
35-40	<b>Unassigned</b>
41	<b>Ambulance—Land</b> —A land vehicle specifically designed, equipped and staffed for lifesaving and transporting the sick or injured.
42	<b>Ambulance—Air or Water</b> —An air or water vehicle specifically designed, equipped and staffed for lifesaving and transporting the sick or injured.
43-50	<b>Unassigned</b>
51	<b>Inpatient Psychiatric Facility</b> —A facility that provides inpatient psychiatric services for the diagnosis and treatment of mental illness on a 24-hour basis, by or under the supervision of a physician.
52	<b>Psychiatric Facility Partial Hospitalization</b> —A facility for the diagnosis and treatment of mental illness that provides a planned therapeutic program for patients who do not require full-time hospitalization, but who need broader programs than are possible from outpatient visits in a hospital-based or hospital-affiliated facility.
53	<b>Community Mental Health Center</b> —A facility that provides comprehensive mental health services on an ambulatory basis primarily to individuals residing or employed in a defined area.
54	<b>Intermediate Care Facility/Mentally Retarded</b> —A facility which primarily provides health-related care and services above the level of custodial care to mentally retarded individuals but does not provide the level of care or treatment available in a hospital or SNF.
55	<b>Residential Substance Abuse Treatment Facility</b> —A facility which provides treatment for substance (alcohol and drug) abuse to live-in residents who do not require acute medical care. Services include individual and group therapy and counseling, laboratory tests, drugs and supplies, psychological testing, and room and board.
56	<b>Psychiatric Residential Treatment Center</b>
57-60	<b>Unassigned</b>
61	<b>Comprehensive Inpatient Rehabilitation Facility</b> —A facility that provides comprehensive rehabilitation services under the supervision of a physician to inpatients with physical disabilities. Services include physical therapy, occupational therapy, speech pathology, social or psychological services, and orthotics and prosthetics services.
62	<b>Comprehensive Outpatient Rehabilitation Facility</b> —A facility that provides comprehensive rehabilitation services under the supervision of a physician to outpatients with physical disabilities. Services include physical therapy, occupational therapy, and speech pathology services.
63-64	<b>Unassigned</b>
65	<b>End Stage Renal Disease Treatment Facility</b> —A facility other than a hospital, which provides dialysis treatment, maintenance and/or training to patients or care givers on an ambulatory or home-care basis.
66-70	<b>Unassigned</b>
71	<b>State or Local Public Health Clinic</b> —A facility maintained by either state or local health departments that provides ambulatory primary medical care under the general direction of a physician.
72	<b>Rural Health Clinic</b> —A certified facility which is located in a rural medically underserved area that provides ambulatory primary medical care under the general direction of a physician.
73-80	<b>Unassigned</b>
81	<b>Independent Laboratory</b> —A laboratory certified to perform diagnostic and/or clinical tests independent of an institution or a physician's office.
82-98	<b>Unassigned</b>

LABOR AND EMPLOYMENT

Relative Value Studies, Inc.  
P.O. Box 6431  
Denver, Colorado 80206  
(303) 329-9787

99	<b>Other Unlisted Facility</b> —Other service facilities not identified above.
Item 23	<b>Radiographs or Models Enclosed</b> —Indicate whether diagnostic materials were submitted.
Item 24	<b>Is Treatment Result of Occupational Illness or Injury?</b> Check yes or no to indicate whether employment related.
Item 25	<b>Is Treatment Result of Auto Accident?</b> Check yes or no to indicate whether injury is related to auto accident.
Item 26	<b>Other Accident</b> —Check yes or no to indicate accident other than employment or auto related.
Item 27	<b>If Prosthesis, Is This The Initial Placement?</b> —Check yes or no.
Item 28	<b>Date of Prior Placement?</b> Enter the date of prior placement if applicable.
Item 29	<b>Is Treatment for Orthodontics?</b> Check appropriate box.
Item 30	<b>Examination and Treatment Plan</b> —Enter the examination and/or plan of treatment. List in order from Tooth #1 through Tooth #32 using the charting system shown.
Item 31	<b>Remarks for Unusual Services</b> —Enter any information which may be helpful in determining the most appropriate benefit for the treatment. If space is inadequate, utilize unused portion of #30, or attach a separate sheet.
<b>Dentist's Signature Block</b> —Must include treating dentist's signature and license number.	
<b>Payment Itemization</b> —The spaces under "Total Fee Charged" will be completed by the carrier.	

AUTHORITY NOTE: Promulgated in accordance with R.S. 23:1034.2.

HISTORICAL NOTE: Promulgated by the Department of Labor, Office of Workers' Compensation, LR 19:1163 (September 1993), amended LR 20:1298 (November 1994).

§5315. Coding System

A. Resources:

1. CDT-1 manual:

Council on Dental Care Programs  
American Dental Association  
211 East Chicago Avenue  
Chicago, Illinois 60611  
(312) 440-2500

2. CPT manual:

AMA Order Dept.  
Box 10946  
Chicago, Illinois 60610  
(800) 621-8335

3. ADA dental claim form:

Council on Dental Care Programs  
American Dental Association  
211 East Chicago Avenue  
Chicago, Illinois 60611  
(312) 440-2500

4. HCPCS Manual

MAP  
671 Executive Drive  
Willowbrook, Illinois 60521  
(312) 440-2500

5. NDAS Manual

National Dental Advisory Service  
P.O. Box 510949  
Milwaukee, WI 53203  
(800) 669-3337

6. Relative Values for Dentists

B. CDT-1 Coding

1. For convenience, the current *Dental Terminology*, First Edition (CDT-1) procedure codes are divided into 12 categories of service. Additional coding systems such as ICD-9, CPT, HCPCS and NDAS coding may also be used in the dental office.

2. Additional dental service codes from *Relative Values for Dentists* have been included where it was felt that more descriptive coding would be beneficial.

3. Procedures denoted "BR" (by report) in the fee schedule should be justified by the submission of a report.

4. All fees should include the price of materials supplied and the performance of the service. Under some circumstances, however, fee adjustments are necessary and values of listed codes may be modified by use of the appropriate "modifier code number." Modifiers available.

22	Unusual Services—Report required.
50	Bilateral or Multiple Field Procedures—Multiple procedures in separate anatomical field. The following values may be used: 100 percent first major procedure. 70 percent each additional field procedure.
51	Multiple Procedures—Multiple procedure in the same anatomical field. The following values may be used: Single Field 100 percent for first major procedure 50 percent of listed value for second 25 percent of listed value for third 10 percent of listed value for fourth 5 percent of listed value for fifth BR for any procedure beyond 5
52	Reduced Values—Reduced or estimated value for procedure because of common practice or at the dentist's election.
53	Primary Emergency Services—Procedure is carried out by a dentist who will not be providing the follow-up care. The value may be 70 percent of the listed value.
54	Surgical Procedure Only—Used to identify the dentist performing surgery. The value may be 70 percent of the listed value.
55	Follow-Up Care Only—Identifies the dentist providing follow-up care. The value may be 30 percent of the listed value.
56	Pre-Operative Care Only—Identifies the dentist performing care up until surgery when another dentist takes over. Value may be 30 percent of the listed value.
75	Services Rendered by More than One Dentist—When the condition requires more than one dentist, each dentist may be allowed 80 percent of the value for that procedure
99	Multiple Modifiers—By Report
The use of modifiers does not imply or guarantee that a provider will receive reimbursement as billed. Reimbursement for modified services or procedures must be based on documentation of medical necessity and must be determined on a case-by-case basis.	

5. Fees for surgical procedures should be global in nature and include the surgery, any local anesthesia and normal follow-up care. Fees for general anesthesia are extra as are complications or additional services and should be coded separately.

AUTHORITY NOTE: Promulgated in accordance with R.S. 23:1034.2.

HISTORICAL NOTE: Promulgated by the Department of Labor, Office of Workers' Compensation, LR 19:1163 (September 1993), amended LR 20:1298 (November 1994), , amended by the Workforce Commission, Office of Workers' Compensation Administration, LR 40:379 (February 2014), LR 42:288 (February 2016).

### §5317. Covered Services

A. Only dental services necessitated by an occupational injury or illness are covered. Such services are provided as a result of damage to the teeth and/or dental work due to a work injury or exposure. In addition, dental appliances and prosthetics not originally purchased by the carrier/self-insured employer will be replaced if damaged or broken in a work-related accident in accordance with the provisions of R.S. 23:1203.

AUTHORITY NOTE: Promulgated in accordance with R.S. 23:1034.2.

HISTORICAL NOTE: Promulgated by the Department of Labor, Office of Workers' Compensation, LR 19:1167 (September 1993), amended LR 20:1298 (November 1994).

### §5319. Procedure Codes and Guidelines

A. The Current Dental Terminology (CDT) is a listing of descriptive terms and identifying codes for reporting dental services and procedures and are used for processing claims benefits. CDT was developed to provide a standard and effective system of reporting dental services to third-party payers for reimbursement. Each procedure or service is identified with a five-digit code. By using these procedures, dental office staff can enhance the speed and accuracy with which a claim may be paid. You should always include the appropriate CDT code(s) when filing a claim.

B. Because medical nomenclature and procedural coding is a rapidly changing field, certain codes may be added, modified or deleted for the next year. Please ensure that your office is using the most current edition of CDT and that you update your codes annually.

AUTHORITY NOTE: Promulgated in accordance with R.S. 23:1034.2.

HISTORICAL NOTE: Promulgated by the Department of Labor, Office of Workers' Compensation, LR 19:1166 (September 1993), amended LR 20:1298 (November 1994).

### §5321. Maximum Allowable Reimbursement

A. Maximum Allowable Reimbursement lists the maximum payment allowed for dental items described by appropriate codes. Payment will be the least of:

1. the seventieth percentile in the current edition of the National Dental Advisory Service (NDAS) Comprehensive Fee Report, utilizing the average of geographic multipliers for Louisiana as published in the NDAS report;

2. a pre-negotiated amount between the provider and carrier/self-insured employer; or

3. the amount indicated in the maximum allowable reimbursement schedule.

AUTHORITY NOTE: Promulgated in accordance with R.S. 23:1034.2.

HISTORICAL NOTE: Promulgated by the Department of Labor, Office of Workers' Compensation, LR 19:1167 (September 1993), amended LR 20:1298 (November 1994), amended by the Workforce Commission, Office of Workers' Compensation, LR 40:379 (February 2014).

### §5329. Special Instructions

#### A. Procedure Codes Not Listed in Rules

1. If a procedure is performed which is not listed in the maximum fee allowance, the health care provider must use an appropriate CDT code descriptor. They submit a narrative report to the carrier to explain why it was medically necessary to use a particular procedure code or descriptor not contained in the maximum fee allowance.

2. The CDT contains codes for unlisted procedures which end in "99." These codes should only be used when there is no procedure code which accurately describes the service rendered. A special report is required as these services are reimbursed by report.

3. Services must be coded with valid five-digit procedure codes.

#### B. By Report (BR)

1. BR refers to the method by which the reimbursement for a procedure is determined by the carrier when a service or procedure is performed by the provider that does not have an established maximum fee allowance.

2. Reimbursement for procedure codes listed as BR must be determined by the carrier based on documentation which is submitted to the carrier by the provider in a special report attached to the claim form. Information in this report must include, as appropriate:

- a. the pertinent history and physical findings;
- b. diagnostic tests and interpretations;
- c. therapeutic procedures;
- d. treatment for concurrent medical conditions;
- e. the final diagnosis/diagnoses;
- f. identification of, or an estimate of the time required for follow-up care;
- g. summary of treatment plan;
- h. copies of operative reports, consultation reports, progress notes, office notes or other applicable documentation;
- i. description of equipment necessary to provide the service.

3. Reimbursement by the carrier of BR procedures should be based upon the carrier's review of the submitted documentation, the recommendation from the carrier's medical consultant, and the carrier's review of the prevailing charges for similar services as identified by the carrier based on data which is representative of Louisiana charges.

LABOR AND EMPLOYMENT

4. Bundled Codes. These codes are marked BR, and are not payable if the service is included in the payment for other services.

AUTHORITY NOTE: Promulgated in accordance with R.S. 23:1034.2.

HISTORICAL NOTE: Promulgated by the Department of Labor, Office of Workers' Compensation, LR 19:1167 (September 1993), amended LR 20:1298 (November 1994).

**§5341. Annual Maintenance**

A. To ensure that the maximum allowable reimbursement schedule is as fair as possible, the Office of Workers' Compensation will require the carriers/self-insured employers to submit the following information for claims incurred in the preceding period.

1. This information will be reviewed and any changes to the maximum allowable reimbursement rates will be published.

B. Information Required. The information required to review and establish appropriate maximum allowable reimbursement rates will include:

Information	Positions	Type
1 CDT-I Code	5	Alpha Numeric
2 Provider Name	30	Alpha Numeric
3 Provider Street Address	30	Alpha Numeric
4 Charge Amount per Procedure	10	Numeric
5 Place of Treatment	2	Numeric
6 Date of Injury (yy/mm/dd)	6	Numeric
7 Claimant Name	30	Alpha
8 Claimant Social Security	9	Numeric
9 Employer Name	20	Alpha Numeric
10 Date of Payment of Bill (yy/mm/dd)	6	Numeric

C. Communication Format. The following is the current format, however, the Office of Workers' Compensation will establish the format on an annual basis to facilitate the review:

1. magnetic tape:
  - a. tape 9-track, 8.5" to 10.5" reels with silver mylar reflector (standard reels) with write-ring removed;
  - b. recording density—1600 or 6250 bytes per inch;
  - c. recording code—extended binary coded decimal interchange code (EBCDIC);
  - d. header record must identify submitter and position of each field in the record;
  - e. tape must have a leading tape mark and an end of file mark;
  - f. the external label must identify the submitter, the date submitted, the tape number with identification of the total number of tapes submitted and the descriptive narrative of the information contained within the records;

2. diskettes:

- a. a 5.25 inch diskette (floppy disk) that is IBM PC-DOS compatible with the following attributes:
  - i. double sided;
  - ii. double density;
  - iii. soft sectored;
  - iv. 9 sectors per track;
  - v. 40 tracks per diskette;
- b. a 3.5 inch, 720K diskette, that is IBM PC-DOS compatible with the following attributes:
  - i. double sided;
  - ii. double density;

c. the external label must identify the submitter, the date submitted, the diskette number with identification of the total number of diskettes submitted and the descriptive narrative of the information contained within the records.

**D. Maintenance Activities**

1. The information submitted will be arrayed in procedure code order.

2. The information for each procedure code will be analyzed to determine the mean value of the charges submitted.

3. This revised information will be published as the update for the maximum allowable reimbursement schedule.

AUTHORITY NOTE: Promulgated in accordance with R.S. 23:1034.2.

HISTORICAL NOTE: Promulgated by the Department of Labor, Office of Workers' Compensation, LR 19:1169 (September 1993), amended LR 20:1298 (November 1994).

**§5399. Schedule for Maximum Allowances for Dental Services**

CDT Code	Description	Maximum Reimbursement
D0120	Periodic oral evaluation—established patient	50
D0140	Limited oral evaluation—problem focused	75
D0145	Oral evaluation—patient under 3 yrs and counseling with primary caregiver	69
D0150	Comprehensive oral evaluation—new or established patient	88
D0160	Detailed and Extensive oral evaluation—problem focused	160
D0170	Re-evaluation—limited, problem focused (established patient; not post-operative visit)	70
D0180	Comprehensive periodontal evaluation—new or established patient	95
D0210	Intraoral—complete series (including bitewings)	128
D0220	Intraoral—periapical first film	28
D0230	Intraoral—periapical each additional film	24
D0240	Intraoral—occlusal films	42
D0250	Intraoral—first film	67
D0260	Extraoral—first film	55
D0270	Bitewing—single film	28
D0272	Bitewing—two films	45
D0273	Bitewing—three films	55
D0274	Bitewing—four films	65
D0277	Vertical bitewings—7 to 8 films	97

CDT Code	Description	Maximum Reimbursement
D0290	Posterior-anterior or lateral skull and facial bone survey film	135
D0310	Sialography	389
D0320	Temporomandibular joint films, including injection	592
D0321	Other temporomandibular joint films	210
D0322	Tomographic survey	530
D0330	Panoramic film	110
D0340	Cephalometric film	125
D0350	Oral/facial photographic images	71
D0360	Cone beam CT—craniofacial data capture	589
D0362	Cone beam CT—two-dimensional image reconstruction using existing data, includes multiple images	359
D0363	Cone beam CT—three-dimensional image reconstruction using existing data, includes multiple images	398
D0415	Collection of microorganisms for culture and sensitivity	186
D0416	Viral culture	168
D0417	Collection and preparation of saliva sample for laboratory diagnostic testing	167
D0418	Analysis of saliva sample	150
D0421	Genetic test for susceptibility to oral diseases	136
D0425	Caries susceptibility tests	95
D0431	Adjunctive pre-diagnostic test that aids in detection of mucosal abnormalities including premalignant and malignant lesions, not to include cytology or biopsy procedures	71
D0460	Pulp vitality tests	55
D0470	Diagnostic casts	109
D0472	Accession of tissue, gross examination, preparation and transmission of written report	118
D0473	Accession of tissue, gross examination and microscopic examination, preparation and transmission of written report	165
D0474	Accession of tissue, gross examination and microscopic examination including assessment of surgical margins for presence of disease, preparation and transmission of written report	184
D0480	Accession of exfoliative cytologic smears, microscopic examination, preparation and transmission of written report	176
D0486	Accession of transepithelial cytologic sample, microscopic examination, preparation and transmission of written report	150
D0475	Decalcification procedure	195
D0476	Special stains for microorganisms	289
D0477	Special stains not for microorganisms	296
D0478	Immunohistochemical stains	175
D0479	Tissue in-situ hybridization, including interpretation	231
D0481	Electron microscopy—diagnostic	188
D0482	Direct immunofluorescence	105
D0483	Indirect immunofluorescence	123
D0484	Consultation on slides prepared elsewhere	168
D0485	Consultation, including preparation of slides from biopsy material supplied by referring source	180
D0502	Other oral pathology procedures	170
D0999	Unspecified diagnostic procedure	BR
D1110	Prophylaxis—adult	90
D1120	Prophylaxis—child	66
D1203	Topical application of fluoride—child	37
D1204	Topical application of fluoride—adult	37
D1206	Topical fluoride varnish; therapeutic application for moderate to high caries risk patients	45
D1310	Nutritional counseling for control of dental disease	70

CDT Code	Description	Maximum Reimbursement
D1320	Tobacco counseling for the control and prevention of oral disease	82
D1330	Oral hygiene instructions	55
D1351	Sealant—per tooth	54
D1352	Preventative resin restoration in a moderate to high caries risk patient—permanent tooth	BR
D1510	Space maintainer—fixed—unilateral	317
D1515	Space maintainer—fixed—bilateral	432
D1520	Space maintainer—removable—unilateral	390
D1525	Space maintainer—removable—bilateral	495
D1550	Re-cementation of space maintainer	83
D1555	Removal of fixed space maintainer	79
D2140	Amalgam—one surface, primary or permanent	138
D2150	Amalgam—two surfaces, primary or permanent	176
D2160	Amalgam—three surfaces, primary or permanent	214
D2161	Amalgam—four surfaces, primary or permanent	251
D2330	Resin-based composite—one surface, anterior	160
D2331	Resin-based composite—two surfaces, anterior	200
D2332	Resin-based composite—three surfaces, anterior	249
D2335	Resin-based composite—four or more surfaces or involving incisal angle (anterior)	312
D2390	Resin-based composite crown—anterior	450
D2391	Resin-based composite—one surface, posterior	177
D2392	Resin-based composite—two surfaces, posterior	230
D2393	Resin-based composite—three surfaces, posterior	284
D2394	Resin-based composite—four or more surfaces posterior	341
D2410	Gold foil—one surface	635
D2420	Gold foil—two surfaces	692
D2430	Gold foil—three surfaces	806
D2510	Inlay—metallic—one surface	833
D2520	Inlay—metallic—two surfaces	892
D2530	Inlay—metallic—three or more surfaces	965
D2542	Onlay—metallic—two surfaces	990
D2543	Onlay—metallic—three surfaces	1015
D2544	Onlay—metallic—four or more surfaces	1050
D2610	Inlay—porcelain/ceramic—one surface	907
D2620	Inlay—porcelain/ceramic—two surfaces	950
D2630	Inlay—porcelain/ceramic—three or more surfaces	995
D2642	Onlay—porcelain/ceramic—two surfaces	1008
D2643	Onlay—porcelain/ceramic—three surfaces	1049
D2644	Onlay—porcelain/ceramic—four or more surfaces	1094
D2650	Inlay—resin based—one surface	869
D2651	Inlay—resin based—two surfaces	904
D2652	Inlay—resin based—three or more surfaces	940
D2662	Onlay—resin based—two surfaces	944
D2663	Onlay—resin based—three surfaces	983
D2664	Onlay—resin based—four or more surfaces	1025
D2710	Crown—resin-based composite (indirect)	940
D2712	Crown—3/4 resin-based composite (indirect)	999
D2720	Crown—resin with high noble metal	1061
D2721	Crown—resin with predominantly base metal	998
D2722	Crown—resin with noble metal	1015
D2740	Crown—porcelain/ceramic substrate	1132
D2750	Crown—porcelain fused to high noble metal	1100
D2571	Crown—porcelain fused predominantly base metal	1029
D2752	Crown—porcelain fused to noble metal	1050
D2780	Crown—3/4 cast high noble metal	1063
D2781	Crown—3/4 cast predominantly base metal	1027
D2782	Crown—3/4 cast noble metal	1030
D2783	Crown—3/4 porcelain /ceramic	1100
D2790	Crown—full cast high noble metal	1100
D2791	Crown—full cast predominantly base metal	997
D2792	Crown—full cast noble metal	1045
D2794	Crown—titanium	1076

LABOR AND EMPLOYMENT

CDT Code	Description	Maximum Reimbursement
D2799	Provisional crown	437
D2910	Recement inlay, only, or partial coverage restoration	108
D2915	Recement cast or prefabricated post and core	114
D2920	Recement crown	109
D2930	Prefabricated stainless steel crown—primary tooth	271
D2931	Prefabricated stainless steel crown—permanent tooth	325
D2932	Prefabricated resin crown	351
D2933	Prefabricated stainless steel crown with resin window	363
D2934	Prefabricated esthetic coated stainless steel crown—primary tooth	372
D2940	Protective restoration	120
D2950	Core buildup, including any pins	271
D2951	Pin retention—per tooth, in addition to restoration	75
D2952	Post and core in addition to crown, indirectly fabricated	422
D2953	Each additional indirectly fabricated post—same tooth	312
D2954	Prefabricated post and core in addition to crown	335
D2955	Post removal (not in conjunction with endodontic therapy)	291
D2957	Each additional prefabricated post—same tooth	200
D2960	Labial veneer (resin laminate)—chairside	658
D2961	Labial veneer (resin laminate)—laboratory	975
D2962	Labial veneer (porcelain laminate)—laboratory	1150
D2970	Temporary crown (fractured tooth)	375
D2971	Additional procedures to construct new crown under existing partial denture framework	169
D2975	Coping	597
D2980	Crown repair	293
D2999	Unspecified restorative procedure,	BR
D3110	Pulp cap—direct (excluding final restoration)	83
D3120	Pulp cap—indirect (excluding final restoration)	84
D3220	Therapeutic pulpotomy (excluding final restoration)—removal of pulp coronal to the dentinocemental junction and application of medicament	198
D3221	Pulpal debridement, primary and permanent teeth	234
D3222	Partial pulpotomy for apexogenesis—permanent tooth with incomplete root development	298
D3230	Pulpal therapy (resorbable filling)—anterior, primary tooth (excluding final restoration)	275
D3240	Pulpal therapy (resorbable filling)—posterior, primary tooth (excluding final restoration)	312
D3310	Endodontic therapy, anterior tooth (excluding final restoration)	725
D3320	Endodontic therapy, bicuspid tooth (excluding final restoration)	842
D3330	Endodontic therapy, molar tooth (excluding final restoration)	1009
D3331	Treatment of root canal obstruction: non-surgical access	611
D3332	Incomplete endodontic therapy; inoperable, unrestorable or fractured tooth	444
D3333	Internal root repair of perforation defects	350
D3346	Retreatment of previous root canal therapy— anterior	850
D3347	Retreatment of previous root canal therapy— bicuspid	970
D3348	Retreatment of previous root canal therapy— molar	1132
D3351	Apexification/recalcification/pulpal regeneration—initial visit (apical closure/calcific repair of perforations, root resorption, pulp space disinfection, etc.)	362

CDT Code	Description	Maximum Reimbursement
D3352	Apexification/recalcification/pulpal regeneration—interim medication replacement (apical closure/calcific repair of perforations, root resorption, pulp space disinfection, etc.)	258
D3353	Apexification/recalcification/pulpal regeneration—final visit (includes completed root canal therapy—apical closure/calcific repair of perforations, root resorption, pulp space disinfection, etc.)	542
D3354	Pupal regeneration—(completion of regenerative treatment in an immature permanent tooth with a necrotic pulp); does not include final restoration	BR
D3410	Apicoectomy/periradicular surgery— anterior	700
D3421	Apicoectomy/periradicular surgery— bicuspid (first root)	780
D3425	Apicoectomy/periradicular surgery— molar (first root)	895
D3426	Apicoectomy/periradicular surgery—(each additional root)	400
D3430	Retrograde filling—per root	280
D3450	Root amputation—per root	483
D3460	Endodontic endosseous implant	1524
D3470	Intentional reimplantation (including necessary splinting)	796
D3910	Surgical procedure for isolation of tooth with rubber dam	235
D3920	Hemisection (including any root removal), not including root canal therapy	474
D3950	Canal preparation and fitting of preformed dowel or post	258
D3999	Unspecified endodontic procedure,	BR
D4210	Gingivectomy or gingivoplasty—four or more contiguous teeth or tooth bounded spaces per quadrant	626
D4211	Gingivectomy or gingivoplasty—one to three contiguous teeth or tooth bounded spaces per quadrant	290
D4230	Anatomical crown exposure—four or more contiguous teeth per quadrant	698
D4231	Anatomical crown exposure—one to three contiguous teeth per quadrant	596
D4240	Gingival flap procedure, including root planing— one to three contiguous teeth or tooth bounded spaces per quadrant	738
D4241	Gingival flap procedure, including root planing— four or more contiguous teeth or tooth bounded spaces per quadrant	635
D4245	Apically positioned flap	819
D4249	Clinical crown lengthening—hard tissue	751
D4260	Osseous surgery (including flap entry and closure)—four or more contiguous teeth or tooth bounded spaces per quadrant	1074
D4261	Osseous surgery (including flap entry and closure)—one to three contiguous teeth or tooth bounded spaces per quadrant	890
D4263	Bone replacement graft—each additional site in quadrant	727
D4264	Bone replacement graft—first site in quadrant	555
D4265	Biologic materials to aid in soft and osseous tissue regeneration	550
D4266	Guided tissue regeneration—resorbable barrier, per site	831
D4267	Guided tissue regeneration—nonresorbable barrier, per site (includes membrane removal)	984
D4268	Surgical revision procedure, per tooth	810
D4270	Pedical soft tissue graft procedure	826
D4271	Free soft tissue graft procedure (including donor site surgery)	895
D4273	Subepithelial connective tissue graft procedures, per tooth	1088

CDT Code	Description	Maximum Reimbursement
D4274	Distal or proximal wedge procedure (when not performed in conjunction with surgical procedures in the same anatomical area)	670
D4275	Soft tissue allograft	969
D4276	Combined connective tissue and double pedicle graft, per tooth	1085
D4320	Provisional splinting—intracoronaral	508
D4321	Provisional splinting—extracoronaral	466
D4341	Periodontal scaling and root planing—four or more teeth per quadrant	251
D4342	Periodontal scaling and root planing—one to three teeth per quadrant	185
D4355	Full mouth debridement to enable comprehensive evaluation and diagnosis	183
D4381	Localized delivery of antimicrobial agents via a controlled release vehicle into diseased crevicular tissue, per tooth,	140
D4910	Periodontal maintenance	139
D4920	Unscheduled dressing change (by someone other than treating dentist)	100
D4999	Unspecified periodontal procedure,	BR
D5110	Complete denture—maxillary	1689
D5120	Complete denture—mandibular	1700
D5130	Immediate denture—maxillary	1831
D5140	Immediate denture—mandibular	1849
D5211	Maxillary partial denture—resin base (including any conventional clasps, rests and teeth)	1350
D5212	Mandibular partial denture—resin base (including any conventional clasps, rests and teeth)	1350
D5213	Maxillary partial denture—cast base framework with resin denture bases (including any conventional clasps, rests and teeth)	1781
D5214	Mandibular partial denture—cast base framework with resin denture bases (including any conventional clasps, rests and teeth)	1780
D5225	Maxillary partial denture—flexible base (including any clasps, rests and teeth)	1566
D5226	Mandibular partial denture—flexible base (including any clasps, rests and teeth)	1552
D5281	Removable unilateral partial denture—one piece cast metal (including clasps and teeth)	995
D5410	Adjust complete denture—maxillary	89
D5411	Adjust complete denture—mandibular	88
D5421	Adjust partial denture—maxillary	88
D5422	Adjust partial denture—mandibular	88
D5510	Repair broken complete denture base	208
D5520	Replace missing or broken teeth—complete denture (each tooth)	186
D5610	Repair resin denture base	202
D5620	Repair cast framework	291
D5630	Repair or replace broken clasp	262
D5640	Replace broken teeth—per tooth	184
D5650	Add tooth to existing partial denture	224
D5660	Add clasp to existing partial denture	268
D5670	Replace all teeth and acrylic on cast metal framework (maxillary)	735
D5671	Replace all teeth and acrylic on cast metal framework (mandibular)	750
D5710	Rebase complete maxillary denture	591
D5711	Rebase complete mandibular denture	585
D5720	Rebase maxillary partial denture	563
D5721	Rebase mandibular partial denture	562
D5730	Reline complete maxillary denture (chairside)	372
D5731	Reline complete mandibular denture (chairside)	369
D5740	Reline maxillary partial denture (chairside)	364
D5741	Reline mandibular partial denture (chairside)	368
D5750	Reline complete maxillary denture (laboratory)	475
D5751	Reline complete mandibular denture (laboratory)	475

CDT Code	Description	Maximum Reimbursement
D5760	Reline maxillary partial denture (laboratory)	469
D5761	Reline mandibular partial denture (laboratory)	472
D5810	Interim complete denture (maxillary)	848
D5811	Interim complete denture (mandibular)	853
D5820	Interim partial denture (maxillary)	690
D5821	Interim partial denture (mandibular)	690
D5850	Tissue conditioning, maxillary	204
D5851	Tissue conditioning, mandibular	205
D5860	Overdenture—complete	2121
D5861	Overdenture—partial	2048
D5862	Precision attachment	700
D5867	Replacement of replaceable part of semi-precision or precision attachment (male or female component)	385
D5875	Modification of removable prosthesis following implant surgery	393
D5899	Unspecified removable prosthodontic procedure	BR
D5911	Facial moulage (sectional)	BR
D5912	Facial moulage (complete)	BR
D5913	Nasal prosthesis	BR
D5914	Auricular prosthesis	BR
D5915	Orbital prosthesis	BR
D5916	Ocular prosthesis	BR
D5919	Facial prosthesis	BR
D5923	Ocular prosthesis, interim	BR
D5924	Cranial prosthesis	BR
D5925	Facial augmentation implant prosthesis	BR
D5926	Nasal prosthesis, replacement	BR
D5957	Auricular prosthesis, replacement	BR
D5958	Orbital prosthesis, replacement	BR
D5929	Facial prosthesis, replacement	BR
D5931	Obturator prosthesis, surgical	BR
D5932	Obturator prosthesis, definitive	BR
D5933	Obturator prosthesis, modification	BR
D5934	Mandibular resection prosthesis with guide flange	BR
D5935	Mandibular resection prosthesis without guide flange	BR
D5936	Obturator prosthesis interim	BR
D5937	Trismus appliance (not for TMD treatment)	746
D5951	Feeding aid	844
D5952	Speech aid prosthesis, pediatric	BR
D5953	Speech aid prosthesis, adult	BR
D5954	Palatal augmentation prosthesis	BR
D5955	Palatal lift prosthesis, definitive	BR
D5958	Palatal lift prosthesis, interim	BR
D5959	Palatal lift prosthesis, modification	BR
D5960	Speech aid prosthesis modification	BR
D5982	Surgical stent	450
D5983	Radiation carrier	BR
D5984	Radiation shield	BR
D5985	Radiation cone locator	BR
D5986	Fluoride gel carrier	210
D5987	Commisssure splint	BR
D5988	Surgical splint	770
D5991	Topical medicament carrier	226
D5992	Adjust maxillofacial prosthetic appliance	BR
D5993	Maintenance and cleaning of maxillofacial prosthesis (extra or intraoral) other than required adjustments	BR
D5999	Unspecified maxillofacial prosthesis	BR
D6190	Radiographic/surgical implant index	375
D6010	Surgical placement of implant body: endosteal implant	2001
D6012	Surgical placement of interim implant body for transitional prosthesis: endosteal implant	1577
D6040	Surgical placement: eposteal implant	8380
D6050	Surgical placement: transosteal implant	5807

LABOR AND EMPLOYMENT

CDT Code	Description	Maximum Reimbursement
D6100	Implant removal	760
D6055	Connecting bar—implant supported abutment support	2900
D6506	Prefabricated abutment—includes placement	789
D6057	Custom abutment—includes placement	952
D6053	Implant/abutment supported removable denture for completely edentulous arch	2790
D6054	Implant/abutment supported removable denture for partially edentulous arch	2751
D6078	Implant/abutment supported fixed denture for completely edentulous arch	5335
D6079	Implant/abutment supported fixed denture for partially edentulous arch	3800
D6058	Abutment supported porcelain/ceramic crown	1479
D6059	Abutment supported porcelain/ceramic crown (high noble metal)	1479
D6060	Abutment supported porcelain fused to metal crown (predominately base metal)	1361
D6061	Abutment supported porcelain fused to metal crown (noble metal)	1382
D6062	Abutment supported cast metal crown (high noble metal)	1432
D6063	Abutment supported cast metal crown (predominantly base metal)	1317
D6064	Abutment supported cast metal crown (noble metal)	1366
D6094	Abutment supported crown—(titanium)	1376
D6065	Implant supported porcelain/ceramic crown	1543
D6066	Implant supported porcelain fused to metal crown (titanium, titanium alloy, high noble metal)	1545
D6067	Implant supported metal crown (titanium, titanium alloy, high noble metal)	1575
D6068	Abutment supported retainer for porcelain/ceramic FPD	1469
D6069	Abutment supported retainer for porcelain fused to metal FPD (high noble metal)	1474
D6070	Abutment supported retainer for porcelain fused to metal FPD (predominantly base metal)	1384
D6071	Abutment supported retainer for porcelain fused to metal FPD (noble metal)	1384
D6072	Abutment supported retainer for cast metal FPD (high noble metal)	1451
D6073	Abutment supported retainer for porcelain cast metal FPD (predominantly base metal)	1384
D6074	Abutment supported retainer for cast metal FPD (noble metal)	1384
D6194	Abutment supported retainer crown for FPD (titanium)	1392
D6075	Implant supported retainer for ceramic FPD	1529
D6076	Implant supported retainer for porcelain fused to metal FPD (titanium, titanium alloy or high noble metal)	1538
D6077	Implant supported retainer for cast metal FPD (titanium, titanium alloy or high noble metal)	1587
D6080	Implant maintenance procedures, including removal of prosthesis, cleansing of prosthesis and abutments and reinsertion of prosthesis	297
D6090	Repair implant supported prosthesis	742
D6095	Repair implant abutment	731
D6091	Replacement of semi-precious or precision attachment (male or female component) of implant/abutment supported prosthesis, per attachment	631
D6092	Recement implant/abutment supported crown	160
D6093	Recement implant/abutment supported fixed partial denture	182
D6199	Unspecified implant procedure	BR
D6205	Pontic—indirect resin based composite	988
D6210	Pontic—cast high noble metal	1089

CDT Code	Description	Maximum Reimbursement
D6211	Pontic—cast predominately base metal	998
D6212	Pontic—cast noble metal	1041
D6214	Pontic—titanium	1100
D6240	Pontic—porcelain fused to high noble metal	1100
D6241	Pontic—porcelain fused to predominantly base metal	1024
D6242	Pontic—porcelain fused to noble metal	1051
D6245	Pontic—porcelain/ceramic	1140
D6250	Pontic—resin with high noble metal	1058
D6251	Pontic—resin with predominantly base metal	1049
D6252	Pontic—resin with noble metal	1040
D6253	Provisional pontic	769
D6254	Interim pontic	BR
D6545	Retainer—cast metal for resin bonded fixed prosthesis	852
D6548	Retainer—porcelain/ceramic for resin bonded fixed prosthesis	950
D6600	Inlay—porcelain/ceramic, two surfaces	1000
D6601	Inlay—porcelain/ceramic, three or more surfaces	1052
D6602	Inlay—cast high noble metal, two surfaces	1015
D6603	Inlay—cast high noble metal, three or more surfaces	1050
D6604	Inlay—predominantly base metal, two surfaces	994
D6605	Inlay—predominantly base metal, three or more surfaces	1046
D6606	Inlay—cast noble metal, two surfaces	998
D6607	Inlay—cast noble metal, three or more surfaces	1050
D6624	Inlay—titanium	1080
D6608	Onlay—porcelain/ceramic, two surfaces	1061
D6609	Onlay—porcelain/ceramic, three or more surfaces	1127
D6610	Onlay—cast high noble metal, two surfaces	1074
D6611	Onlay—cast high noble metal, three or more surfaces	1111
D6612	Onlay—predominantly base metal, two surfaces	1038
D6613	Onlay—predominantly base metal, three or more surfaces	1095
D6614	Onlay—cast noble metal, two surfaces	1050
D6615	Onlay—cast noble metal, three or more surfaces	1102
D6634	Onlay—titanium	1125
D6710	Crown—indirect resin based composite	1025
D6720	Crown—resin with high noble metal	1056
D6721	Crown—resin with predominantly base metal	1032
D6722	Crown—resin with noble metal	1050
D6740	Crown—porcelain/ceramic	1146
D6750	Crown—porcelain fused to high noble metal	1107
D6751	Crown—porcelain fused to predominantly base metal	1010
D6752	Crown—porcelain fused to noble metal	1050
D6780	Crown—3/4 cast high noble metal	1075
D6781	Crown—3/4 cast predominantly base metal	1038
D6782	Crown—3/4 cast noble metal	1050
D6783	Crown—3/4 porcelain/ceramic	1100
D6790	Crown—full cast high noble metal	1085
D6791	Crown—full cast predominantly base metal	997
D6792	Crown—full cast noble metal	1040
D6794	Crown—titanium	1059
D6793	Provisional retainer crown	523
D6795	Interim retainer crown	BR
D6920	Connector bar	995
D6930	Recement fixed partial denture	171
D6940	Stress breaker	435
D6950	Precision attachment	650
D6970	Post and core in addition to fixed partial denture retainer, indirectly fabricated	433
D6972	Prefabricated post and core in addition to fixed partial denture retainer	344
D6973	Core build up for retainer, including any pins	275



CDT Code	Description	Maximum Reimbursement
D6975	Coping—metal	700
D6976	Each additional indirectly fabricated post—same tooth	290
D6977	Each additional prefabricated post—same tooth	204
D6980	Fixed partial denture repair	387
D6985	Pediatric partial denture, fixed	915
D6999	Unspecified fixed prosthodontic procedure	BR
D7111	Extraction, coronal remnants—deciduous tooth	135
D7140	Extraction, erupted tooth or exposed root (elevation and/or forceps removal)	174
D7210	Surgical removal of erupted tooth requiring removal of bone and/or sectioning of tooth, and including elevation of mucoperiosteal flap if indicated	275
D7220	Removal of impacted tooth—soft tissue	315
D7230	Removal of impacted tooth—partially bony	395
D7240	Removal of impacted tooth—completely bony	484
D7241	Removal of impacted tooth—completely bony, with unusual surgical complications	576
D7250	Surgical removal of residual tooth roots (cutting procedure)	304
D7251	Coronectomy—intentional partial tooth removal	BR
D7260	Oroantral fistula closure	1026
D7261	Primary closure of a sinus perforation	757
D7270	Tooth reimplantation and/or stabilization of accidentally evulsed or displaced tooth	561
D7272	Tooth transplantation (includes reimplantation from one site to another and splinting and/or stabilization)	746
D7280	Surgical access of an unerupted tooth	482
D7282	Mobilization of erupted or malpositioned tooth to aid eruption	526
D7283	Placement of device to facilitate eruption of impacted tooth	523
D7285	Biopsy of oral tissue—hard (bone, tooth)	437
D7286	Biopsy of oral tissue—soft	320
D7287	Exfoliative cytological sample collection	184
D7288	Brush biopsy—transepithelial sample collection	195
D7290	Surgical repositioning of teeth	528
D7291	Transseptal fibrotomy/surpa crestal fibrotomy	315
D7292	Surgical placement: temporary anchorage device [screw retained plate] requiring surgical flap	3300
D7293	Surgical placement: temporary anchorage device requiring surgical flap	2528
D7294	Surgical placement: temporary anchorage device without surgical flap	1619
D7295	Harvest of bone for use in autogenous grafting procedure	BR
D7310	Alveoplasty in conjunction with extractions—four or more teeth or tooth spaces, per quadrant	295
D7311	Alveoplasty in conjunction with extractions—one to three teeth or tooth spaces, per quadrant	309
D7320	Alveoplasty not in conjunction with extractions—four or more teeth or tooth spaces, per quadrant	443
D7321	Alveoplasty not in conjunction with extractions—one to three teeth or tooth spaces, per quadrant	437
D7340	Vestibuloplasty—ridge extension (secondary epithelialization)	1164
D7350	Vestibuloplasty—ridge extension (including soft tissue graft, muscle reattachment, revision of soft tissue attachment and management of hypertrophied and hyperplastic tissue)	2467
D7410	Excision of benign lesion up to 1.25 cm	415
D7411	Excision of benign lesion greater than 1.25 cm	630
D7412	Excision of benign lesion, complicated	850
D7413	Excision of malignant lesion greater than 1.25 cm	751
D7414	Excision of malignant lesion up to 1.25 cm	1132

CDT Code	Description	Maximum Reimbursement
D7415	Excision of malignant lesion, complicated	1253
D7465	Destruction of lesion(s) by physical or chemical method	459
D7440	Excision of malignant tumor—lesion diameter up to 1.25 cm	720
D7441	Excision of malignant tumor—lesion greater than 1.25 cm	1224
D7450	Removal of benign odontogenic cyst or tumor—lesion diameter up to 1.25 cm	588
D7451	Removal of benign odontogenic cyst or tumor—lesion diameter greater than 1.25 cm	782
D7460	Removal of benign nonodontogenic cyst or tumor—lesion diameter greater than 1.25 cm	573
D7461	Removal of benign nonodontogenic cyst or tumor—lesion diameter up to 1.25 cm	874
D7470	Removal of lateral exostosis (maxilla or mandible)	653
D7472	Removal of torus palatinus	859
D7473	Removal of torus mandibularis	761
D7485	Surgical reduction of osseous tuberosity	755
D7490	Radial resection of maxilla or mandible	8006
D7510	Incision and drainage of abscess—intraoral soft tissue	236
D7511	Incision and drainage of abscess—intraoral soft tissue—complicated (includes drainage of multiple fascial spaces)	367
D7520	Incision and drainage of abscess—extraoral tissue	169
D7521	Incision and drainage of abscess—extraoral tissue—complicated (includes drainage of multiple fascial spaces)	630
D7530	Removal of foreign body from mucosa, skin, or subcutaneous alveolar tissue	364
D7540	Removal of reaction producing foreign bodies, musculoskeletal system	708
D7550	Partial osteotomy/sequestrectomy for removal of non-vital bone	600
D7560	Maxillary sinusotomy for removal of tooth fragment or foreign body	1308
D7610	Maxilla—open reduction (teeth immobilized, if present)	4464
D7620	Maxilla—closed reduction (teeth immobilized, if present)	3450
D7630	Mandible—open reduction (teeth immobilized, if present)	4576
D7640	Mandible—closed reduction (teeth immobilized, if present)	3483
D7650	Malar and/or zygomatic arch—open reduction	3924
D7660	Malar and/or zygomatic arch—closed reduction	3277
D7670	Alveolus closed reduction may include stabilization of teeth	1746
D7671	Alveolus open reduction may include stabilization of teeth	1298
D7680	Facial bones—complicated reduction with fixation and multiple surgical approaches	6555
D7710	Maxilla open reduction	4568
D7720	Maxilla—closed reduction	3462
D7730	Mandible—open reduction	4826
D7740	Mandible—closed reduction	3636
D7750	Malar and/or zygomatic arch—open reduction	4230
D7760	Malar and/or zygomatic arch—closed reduction	6044
D7770	Alveolus open reduction stabilization of teeth	2794
D7771	Alveolus closed reduction stabilization of teeth	1958
D7780	Facial bones—complicated reduction with fixation and multiple surgical approaches	8587
D7810	Open reduction of dislocation	4271
D7820	Closed reduction of dislocation	644
D7830	Manipulation under anesthesia	990
D7840	Condylectomy	5466

LABOR AND EMPLOYMENT

CDT Code	Description	Maximum Reimbursement
D7850	Surgical discectomy, with/without implant	5356
D7852	Disc repair	5541
D7854	Synovectomy	5278
D7856	Myotomy	3505
D7858	Joint reconstruction	BR
D7860	Arthrotomy	BR
D7865	Arthroplasty	BR
D7870	Arthrocentesis	562
D7871	Non-arthroscopic lysis and lavage	BR
D7872	Arthroscopy—diagnosis, with or without biopsy	BR
D7873	Arthroscopy—surgical: lavage and lysis of adhesions	BR
D7874	Arthroscopy—surgical: disc repositioning and stabilization	BR
D7875	Arthroscopy—surgical: synovectomy	BR
D7876	Arthroscopy—surgical: discectomy	BR
D7877	Arthroscopy—surgical: debridement	BR
D7880	Occlusal orthotic device	990
D7899	Unspecified TMD therapy	BR
D7910	Suture of recent small wounds up to 5 cm	300
D7911	Complicated suture—up to 5 cm	486
D7912	Complicated suture—greater than 5 cm	792
D7920	Skin graft (identify defect covered, location and type of graft)	2677
D7940	Osteoplasty—for orthognathic deformaties	4123
D7941	Osteotomy—mandibular rami	9139
D7943	Osteotomy—mandibular rami with bone graft; includes obtaining the graft	8623
D9744	Osteotomy—segmented or subapical	7006
D7945	Osteotomy—body of mandible	6983
D7946	LeFort I (maxilla—total)	8251
D7947	LeFort I (maxilla—segmentedl)	8393
D7948	LeFort II or LeFort III (osteoplasty of facial bones for midface hypoplasia or retrusion)—without bone graft	9586
D7949	LeFort II of LeFort III—with bone graft	11832
D7950	Osseous, osteoperiosteal or cartilage graft of the mandible or maxilla—autogenous or nonautogenous	3116
D7951	Sinus augmentation with bone or bone substitutes	3200
D7953	Bone replacement graft for ridge preservation—per site	800
D7955	Repair of maxillofacial soft and/or hard tissue defect	3807
D7960	Frenulectomy—also known as frenectomy or frenotomy—separate procedure not incidental to another procedure	450
D7936	Frenuloplasty	499
D7970	Excision of hyperplastic tissue—per arch	517
D7971	Excision of pericoronal gingiva	258
D7972	Surgical reduction of fibrous tuberosity	796
D7980	Sialolithotomy	843
D7981	Excision of salivary gland	BR
D7982	Sialodochoplasty	1749
D7983	Closure of salivary fistula	1528
D7990	Emergency tracheotomy	1482
D7991	Coronoidectomy	4056
D7995	Synthetic graft—mandible or facial bones	BR
D7996	Implant-mandible for augmentation purposes (excluding alveolar ridge)	BR
D7997	Appliance removal (not by dentist who place appliance), includes removal of archbar	350
D7998	Intraoral placement of a fixation device not in conjunction with a fracture	2572
D7999	Unspecified oral surgery procedure	BR
D8010	Limited orthodontic treatment of the primary dentition	2149

CDT Code	Description	Maximum Reimbursement
D8020	Limited orthodontic treatment of the transitional dentition	2459
D8030	Limited orthodontic treatment of the adolescent dentition	2901
D8040	Limited orthodontic treatment of the adult dentition	3237
D8050	Interceptive orthodontic treatment of the primary dentition	2590
D8060	Interceptive orthodontic treatment of the transitional dentition	2796
D8070	Comprehensive orthodontic treatment of the transitional dentition	5200
D8080	Comprehensive orthodontic treatment of the adolescent dentition	5250
D8090	Comprehensive orthodontic treatment of the adult dentition	5308
D8210	Removable appliance therapy	861
D8220	Fixed appliance therapy	968
D8660	Pre-orthodontic treatment visit	384
D8670	Periodic orthodontic treatment visit (as part of contract)	263
D8680	Orthodontic retention (removal of appliances, construction and placement of retainers(s))	532
D8690	Orthodontic treatment (alternative billing to a contract fee)	283
D8691	Repair of orthodontic appliance	210
D8692	Replacement of lost or broken retainer	330
D8693	Rebonding or recementing; and/or repair as require, of fixed retainers	356
D8999	Unspecified orthodontic procedure,	BR
D9110	Palliative (emergency) treatment of dental pain—minor procedure	126
D9120	Fixed partial denture sectioning	250
D9210	Local anesthesia not in conjunction with operative or surgical procedures	74
D9211	Regional block anesthesia	96
D9212	Trigeminal division block anesthesia	272
D9215	Local anesthesia in conjunction with operative or surgical procedures	65
D9220	Deep sedation/general anesthesia—first 30 minutes	392
D9221	Deep sedation/general anesthesia—each additional 15 minutes	174
D9230	Inhalation of nitrous oxide/anxiolysis analgesia	79
D9241	Intravenous conscious sedation/analgesia—first 30 minutes	416
D9242	Intravenous conscious sedation/analgesia—each additional 15 minutes	169
D9248	Non-intravenous conscious sedation	325
D9310	Consultation—diagnostic services provided by dentist or physician other than requesting dentist or physician	129
D9410	House/extended care facility call	246
D9420	Hospital or ambulatory surgery center call	299
D9430	Office visit for observation (during regularly scheduled hours)—no other services performed	76
D9440	Office visit after regularly scheduled hours	179
D9450	Case presentation, detailed and extensive treatment planning	145
D9610	Therapeutic parental drug, single administration	111
D9612	Therapeutic parental drug, two or more administrations, different medications	193
D9630	Other drugs and/or medicaments	49
D9910	Application of desensitizing medicament	63
D9911	Application of desensitizing resin for cervical and/or root surface, per tooth	79
D9920	Behavior management	160
D9930	Treatment of complications (post-surgical)—unusual circumstances	132

Title 40, Part I

CDT Code	Description	Maximum Reimbursement
D9940	Occlusal guard,	600
D9941	Fabrication of athletic mouthguard	254
D9942	Repair and/or reline of occlusal guard	250
D9950	Occlusion analysis—mounted case	344
D9951	Occlusal adjustment—limited	182
D9952	Occlusal adjustment—complete	687
D9970	Enamel microabrasion	202
D9971	Odontoplasty 1-2 teeth; includes removal of enamel projections	176
D9972	External bleaching—per arch	328
D9973	External bleaching—per tooth	231
D9974	Internal bleaching—per tooth	291

CDT Code	Description	Maximum Reimbursement
D9999	Unspecified adjunctive procedure	BR

AUTHORITY NOTE: Promulgated in accordance with R.S. 23:1034.2.

HISTORICAL NOTE: Promulgated by the Department of Labor, Office of Workers' Compensation, LR 19:1167 (September 1993), amended LR 20:1298 (November 1994), amended by the Workforce Commission, Office of Workers' Compensation, LR 39:2043 (July 2013), LR 40:379 (February 2014), LR 42:289 (February 2016).



**Title 40**  
**LABOR AND EMPLOYMENT**  
**Part I. Workers' Compensation Administration**  
**Subpart 3. Hearing Rules**

**Chapter 55. General Provisions**

**Subchapter A. Definitions**

**§5501. Purpose; Definitions**

A. The purpose of these rules is to govern the practice and procedures before the Workers' Compensation Court which is a statewide court having jurisdiction of claims for workers' compensation benefits, the controversion of entitlement to benefits and other relief under the Workers' Compensation Act. These rules are designed to facilitate the equitable, expeditious and simple resolution of workers' compensation disputed claims filed with the Court.

B. As used in these rules, unless otherwise indicated the following words shall have the following meanings.

*Claimant*—shall refer to the injured employee.

*Court*—the Office of Workers' Compensation court within the Office of Workers' Compensation Administration of the Louisiana Department of Labor.

*Director*—the director of the Office of Workers' Compensation Administration of the Louisiana Department of Labor.

*Judge*—a workers' compensation judge.

*Judicial District*—as referred to in R.S. 1310.4, any of the 10 locations of a workers' compensation district office, i.e. Shreveport, Monroe, Alexandria, Lake Charles, Lafayette, Baton Rouge, Covington, New Orleans, Harahan, Houma, and the parishes each encompass.

*Mediator*—a workers' compensation mediator.

*Office*—the Office of Workers' Compensation Administration of the Louisiana Department of Labor.

*Petitioner*—shall, as the context requires, mean the employer, the insurance carrier, the group self-insurance fund, the health care provider, claimant, or a dependant of a claimant.

AUTHORITY NOTE: Promulgated in accordance with R.S. 23:1310.1.

HISTORICAL NOTE: Promulgated by the Department of Labor, Office of Workers' Compensation Administration, LR 25:264 (February 1999), amended LR 25:1859 (October 1999), LR 33:652 (April 2007), amended by the Louisiana Workforce Commission, Office of Workers' Compensation, LR 37:1626 (June 2011).

**Subchapter B. Jurisdiction**

**§5503. Jurisdiction Authority**

A. Jurisdiction over workers' compensation matters is conferred upon the Office of Workers' Compensation Administration pursuant to Louisiana Constitution Article V, §16.A.(1) and R.S. 23:1310.3, et seq.

AUTHORITY NOTE: Promulgated in accordance with R.S. 23:1310.1.

HISTORICAL NOTE: Promulgated by the Department of Labor, Office of Workers' Compensation Administration, LR 25:265 (February 1999), amended LR 25:1859 (October 1999).

**§5505. Jurisdiction over Subject Matter and Persons**

A. Jurisdiction of the workers' compensation judges shall be governed by R.S. 23:1310.3.

AUTHORITY NOTE: Promulgated in accordance with R.S. 23:1310.1.

HISTORICAL NOTE: Promulgated by the Louisiana Department of Labor, Office of Workers' Compensation Administration, LR 25:265 (February 1999), amended LR 25:1860 (October 1999).

**Subchapter C. Commencement**

**§5507. Commencement of a Claim**

A. "Form LWC-WC-1008" shall be the form to initiate a claim or dispute arising out of chapter 10 of title 23 of the *Louisiana Revised Statutes* of 1950, except that:

B. Any claim may be initiated with the director, office of worker's compensation administration, or the district office of proper venue by hand delivery, United States mail, facsimile transmission or electronic transmission (with verified signature) addressed to the Office of Worker's Compensation administration.

C. Any party aggrieved by the R.S. 23:1203.1(J) determination of the medical director may seek judicial review by filing a Form LWC-WC-1008 in a workers' compensation district office within 15 days of the date said determination is mailed to the parties. A party filing an appeal under this Section must simultaneously notify the other party and the medical director that an appeal of the medical director's decision has been filed. Upon receipt of the appeal, the workers' compensation judge shall immediately set the matter for an expedited hearing to be held not less than 15 days nor more than 30 days after the receipt of the appeal by the office. The workers' compensation judge shall provide notice of the hearing date to the parties at the same time and in the same manner.

D. Any request for a preliminary determination pursuant to *Louisiana Revised Statutes* title 23, section 1201.1 shall be made in the answer or amended answer and shall be accompanied by a copy of the LWC-WC-1002 and notice of disagreement, along with a motion and order to set telephone status conference attached and shall proceed with the following steps.

1. A telephone conference shall be set within 15 days from receipt of the answer or amended answer with accompanying attachments. A preliminary determination hearing shall be set within 90 days from telephone status conference. The deadline for any discovery shall be 30 days before the preliminary determination hearing. The parties must exchange evidence 15 days before the hearing, with copies of the exhibits, exhibit list and memorandum sent to the presiding workers' compensation judge.

2. The workers' compensation judge or the judge's designee, shall advise all parties of the deadlines set forth hereinabove in the telephone status conference.

3. A scheduling conference order shall be forwarded to the parties within three days of the telephone status conference. The order shall include a list of issues to be determined, the date of the scheduled hearing, the deadline for discovery, the deadline for the exchange of exhibits, the deadline for the submission of exhibits and the deadline for the submission of memoranda to the court.

4. After the preliminary determination hearing, the court shall forward a written preliminary determination to the parties within 30 days of the hearing.

5. A notice shall accompany the written preliminary determination. The notice shall advise the parties of their options to accept or reject the finding and it shall advise the parties that, if the court does not receive written notification within 15 days of further action by the parties, the court will close the file or proceed to trial on the merits on all remaining issues.

AUTHORITY NOTE: Promulgated in accordance with R.S. 23:1310.1(C).

HISTORICAL NOTE: Promulgated by the Department of Labor, Office of Workers' Compensation Administration, LR 25:265 (February 1999) amended LR 25:1860 (October 1999), LR 33:652 (April 2007), amended by the Workforce Commission, Office of Workers' Compensation, LR 37:1626 (June 2011), LR 41:560 (March 2015).

#### **§5509. Delay for Answering**

A. A defendant shall file his answer within 15 days after service of the citation in accordance with Code of Civil Procedure Articles 1001, 1005 and 1006. The defendant shall certify that a copy of the answer was sent to all parties to the claim.

B. The filing of the answer shall be deemed timely when the answer is filed as provided in R.S. 23:1310.3.D.

AUTHORITY NOTE: Promulgated in accordance with R.S. 23:1310.1.

HISTORICAL NOTE: Promulgated by the Department of Labor, Office of Workers' Compensation Administration, LR 25:265 (February 1999), amended LR 25:1860 (October 1999), LR 33:652 (April 2007).

#### **§5511. Service**

A. Service of process in a workers' compensation claim shall be as provided for in R.S. 23:1310.3(C).

AUTHORITY NOTE: Promulgated in accordance with R.S. 23:1310.1.

HISTORICAL NOTE: Promulgated by the Department of Labor, Office of Workers' Compensation Administration, LR 25:265 (February 1999), amended LR 25:1860 (October 1999), LR 33:652 (April 2007), amended by the Louisiana Workforce Commission, Office of Workers' Compensation, LR 37:1626 (June 2011).

### **Subchapter D. Venue**

#### **§5515. Proper Venue**

A. Proper venue in a workers' compensation claim shall be governed by R.S. 23:1310.4.

B. When the claimant or his dependent is not a party to the disputed claim, the petitioner shall have the right to select the venue of necessary hearings by the workers' compensation judge as provided in the Code of Civil Procedure.

AUTHORITY NOTE: Promulgated in accordance with R.S. 23:1310.1.

HISTORICAL NOTE: Promulgated by the Department of Labor, Office of Workers' Compensation Administration, LR 25:265 (February 1999), amended LR 25:1860 (October 1999), LR 33:652 (April 2007), amended by the Louisiana Workforce Commission, Office of Workers' Compensation, LR 37:1626 (June 2011), amended by the Workforce Commission, Office of Workers' Compensation Administration, LR 41:2692 (December 2015).

### **Subchapter E. Recusal**

#### **§5525. Procedure for Recusal of a Workers' Compensation Judge**

A. Recusal of a workers' compensation judge shall be governed by Code of Civil Procedure Article 151.

B. A workers' compensation judge may recuse himself, prior to a judgment being rendered, whether a motion for his recusation has been filed by a party or not, in any cause in which a ground for recusation exists.

C. If a judge recuses himself pursuant to this Section, he shall provide in writing to the Chief Judge the specific grounds under Code of Civil Procedure Article 151 for which the recusal is ordered within 15 days of the rendering of the order of recusal.

D. On written application of a workers' compensation judge, the chief judge shall immediately reassign the matter to another workers' compensation judge in either the same workers' compensation district office or another workers' compensation district office.

E. Any party to a workers' compensation claim may file a written motion for recusal of the judge to whom the matter is assigned specifying the grounds for recusal. This motion shall be filed prior to trial or hearing unless the party discovers the facts constituting the ground for recusal thereafter. In such case, the motion shall be filed immediately after the facts are discovered, but in no case

after judgment. If a valid ground for recusal is set forth in the motion, the judge shall either recuse himself or refer the matter to the chief judge. Upon receipt of the motion the chief judge shall either try the motion or assign it to another workers' compensation judge for trial. Trial of the motion shall be held in an expedited manner and in no event later than 14 days following filing of the motion.

F. If a valid ground for recusal is not set forth in the motion, the judge shall deny the motion and proceed with the trial of the cause. Any party aggrieved by any denial may file an appeal in accordance with the provisions of R.S. 23:1310.5.

G. Consolidated cases are to be considered as one case within the meaning of this Section.

**AUTHORITY NOTE:** Promulgated in accordance with R.S. 23:1310.1.

**HISTORICAL NOTE:** Promulgated by the Department of Labor, Office of Workers' Compensation Administration, LR 25:1860 (October 1999), amended LR 33:652 (April 2007), amended by the Louisiana Workforce Commission, Office of Workers' Compensation, LR 37:1626 (June 2011).

## Subchapter F. Power and Authority

### §5533. General

A. Workers' compensation judges shall have the power to enforce any lawful order and the discretionary authority to use necessary sanctions, including dismissal, in order to control the orderly process of the hearing, enforce orders, and these rules.

B. All workers' compensation judges shall be subject to the Code of Judicial Conduct, Civil Service Rules, the Louisiana Code of Governmental Ethics and the Louisiana State Bar Association Code of Professional Conduct.

C. All workers' compensation mediators shall be subject to the Civil Service Rules, the Louisiana Code of Governmental Ethics, and the Louisiana State Bar Association Code of Professional Conduct.

D. A workers' compensation judge or mediator shall not refer any claimant to an attorney for representation in a workers' compensation matter except under the following circumstances:

1. when ordered to appoint an attorney for an unrepresented party by a court of competent jurisdiction;
2. except as provided in §5709.B of these rules; or
3. when the judge has a reasonable belief that the unrepresented party lacks capacity to represent himself.

F. The court shall have available a list of attorneys, compiled by the director, who have indicated a willingness to handle workers' compensation matters.

**AUTHORITY NOTE:** Promulgated in accordance with R.S. 23:1310.1.

**HISTORICAL NOTE:** Promulgated by the Department of Labor, Office of Workers' Compensation Administration, LR 25:266 (February 1999), amended LR 25:1860 (October 1999), LR 33:653 (April 2007), amended by the Louisiana Workforce

Commission, Office of Workers' Compensation, LR 37:1627 (June 2011).

### §5534. Submission and Investigation of Complaints alleging Judicial Misconduct or Disability

A. Complaints alleging misconduct or disability on the part of any workers' compensation judge shall be submitted to the director in writing, and shall include:

1. the complainant's full name, address, and telephone number;
2. the judge's name and assigned court;
3. a statement detailing the alleged misconduct or disability, including all underlying facts and the names and addresses of any persons having knowledge relevant to the complaint, and if known, the particular judicial cannons, rules of professional conduct, Civil Service rules, or other rules allegedly violated;
4. copies of any pleadings, orders, judgments, or other documents relevant to the complaint;
5. if the alleged misconduct or disability concerns a specific matter pending before the judge, the complainant shall list all parties thereto and/or their counsel of record, and shall certify that a copy of the complaint has been provided to them via facsimile, other electronic transmission, or by certified mail.

B. Upon receipt of the complaint, the director or his designee shall commence a preliminary review. Complaints which solely criticize a judge's official decision making or claim judicial error subject to appellate review, or which fail to comply with Subsection A of this Section, shall be screened out as frivolous, and notification of rejection shall be sent to the complainant and all persons identified per Paragraph A.5 of this Section.

C. The director or his designee shall investigate all non-frivolous complaints as deemed reasonable and necessary. Pursuant to the investigation, a copy of the complaint shall be provided to the judge who is subject thereof, who shall provide a written answer within 10 days of receiving the complaint, setting forth a response to the allegations and including any appropriate commentary or explanation.

D. Within 60 days of receipt of the original complaint by the office, the director shall determine any disciplinary action to be taken. A copy of the decision shall be provided contemporaneously to the judge who is the subject of the complaint.

E. Nothing herein shall prevent a complainant from seeking any other remedy allowed by law.

**AUTHORITY NOTE:** Promulgated in accordance with R.S. 23:1310.1(C) and R.S. 23:1291.

**HISTORICAL NOTE:** Promulgated by the Workforce Commission, Office of Workers' Compensation Administration, LR 41:2691 (December 2015).

### §5535. Contempt

A. Contempt of court is any act or omission tending to obstruct or interfere with the orderly administration of

**LABOR AND EMPLOYMENT**

justice, or to impair the dignity of the court or respect for its authority.

B. Contempt proceedings in a workers' compensation proceeding shall be governed by R.S. 23:1310.7.B. This procedure is favored and shall be construed to accomplish the just, speedy, and orderly process of the hearing.

AUTHORITY NOTE: Promulgated in accordance with R.S. 23:1310.1.

HISTORICAL NOTE: Promulgated by the Louisiana Department of Labor, Office of Workers' Compensation Administration, LR 25:266 (February 1999), amended LR 25:1861 (October 1999).

**§5537. Procedure**

A. The procedure for contempt of court shall be as found in R.S. 23:1310.7.

B. Form for Judges to Report Contempt Findings

<b>WORKERS' COMPENSATION CONTEMPT FINDINGS FORM</b>	
<b>Note:</b> Form due to Assistant Secretary within 30 days of ruling per La. R.S. 23:1310.7	
SECTION I: DOCKET CASE INFORMATION (print please)	
1. Plaintiff Party Name	1a. Attorney (if any)
2. Defendant Party Name	2a. Attorney (if any)
3. Judge's Name	4. Date of Event/Hearing
5. District #	6. City
SECTION II: FACTS	
1. Name of Party in Contempt	
2. Parties to the claim and their relationship (ex: John Brown, claimant) :	
3. Code of Civil Procedure Violation (check all that apply):	
<input type="checkbox"/> Article 222- Direct Contempt # of violations _____ Total amount of civil fines assessed \$ _____ Summarize actions used to discourage behavior: _____ _____ _____	
<input type="checkbox"/> Article 224- Constructive Contempt # of violations _____ Total amount of civil fines assessed \$ _____ Summarize actions used to discourage behavior: _____ _____ _____	
4. Attach written reasons issued with ruling	
Signature of Judge _____	Date _____
Signature of Chief Judge _____	Date _____
Signature of Assistant Secretary _____	Date _____

AUTHORITY NOTE: Promulgated in accordance with R.S. 23:1310.1.

HISTORICAL NOTE: Promulgated by the Department of Labor, Office of Workers' Compensation Administration, LR

25:266 (February 1999), amended LR 25:1861 (October 1999), LR 33:653 (April 2007), amended, LR 48:2995 (December 2022).



## Subchapter G. Clerks

### §5539. District Clerk; Pleadings Filed; Docket Books

A. Each workers' compensation district and the records management division shall have a clerk(s), who shall have the authority to certify records of the office. The supervisor of the records management division shall be the custodian of all records and documents for that district or the office and no such records, documents, or paper shall be withdrawn.

B. The manager of the records management division shall be the custodian of all records and documents for that district or offices and no such records, documents, or paper shall be withdrawn.

C. The manager of the records management division shall be the custodian of all records and documents for that district or offices and no such records, documents, or paper shall be withdrawn.

AUTHORITY NOTE: Promulgated in accordance with R.S. 23:1310.1.

HISTORICAL NOTE: Promulgated by the Department of Labor, Office of Workers' Compensation Administration, LR 25:266 (February 1999), amended LR 25:1861 (October 1999), LR 33:653 (April 2007), amended by the Louisiana Workforce Commission, Office of Workers' Compensation, LR 37:1627 (June 2011).

## Subchapter H. Bailiffs

### §5541. Security

A. The term "Bailiff" shall refer to any peace officer or duly commissioned reserve officer assigned by the director to maintain order at each workers' compensation court.

B. The bailiff may in his discretion, or as ordered by the judge, inspect any object carried by any person entering the premises. No one shall enter or remain in the premises without submitting to such an inspection if requested to do so.

C. Unless authorized by the judge, no camera, recording equipment or other type of electrical or electronic device shall be brought into the premises.

D. No person shall be admitted to or allowed to remain in the premises with any object that might be employed as a weapon unless he or she has been authorized in writing by the workers' compensation judge to do so, or unless he or she is a peace officer or duly commissioned reserve officer.

E. The bailiff shall enforce the whole of this rule, and pursuant to his authority as a peace officer or duly commissioned reserve officer, shall be authorized in his discretion to take any legal action necessary to preserve the order and security of the premises.

AUTHORITY NOTE: Promulgated in accordance with R.S. 23:1310.1.

HISTORICAL NOTE: Promulgated by the Department of Labor, Office of Workers' Compensation Administration, LR 25:266 (February 1999), amended LR 25:1861 (October 1999), LR 33:653 (April 2007), amended by the Louisiana Workforce

Commission, Office of Workers' Compensation, LR 37:1627 (June 2011).

## Subchapter I. Attorneys and Other Persons before the Court

### §5543. Workers' Compensation Courtroom Decorum

A. The following shall be observed in the opening of workers' compensation court and general courtroom decorum.

1. The bailiff shall open each session of workers' compensation court with an appropriate recitation and order.

2. No tobacco in any form will be permitted at any time.

3. No food or beverage shall be brought into the courtroom.

B. As officers of the workers' compensation court, attorneys are reminded of their obligations to assist in maintaining the dignity of the court. All attorneys and other officers of the court shall dress appropriately. For gentlemen, this means a coat and tie. For ladies, this means appropriate professional attire.

AUTHORITY NOTE: Promulgated in accordance with R.S. 23:1310.1.

HISTORICAL NOTE: Promulgated by the Louisiana Department of Labor, Office of Workers' Compensation Administration, LR 25:267 (February 1999), amended LR 25:1861 (October 1999).

### §5545. Attorneys

A. In all hearings before the Workers' Compensation Judge the parties may appear in person or by counsel licensed to practice law in the state of Louisiana. Corporate entities, unincorporated associations, insurance companies and own-risk carrier shall appear only by such counsel. Counsel who will appear before the Workers' Compensation Judge on behalf of a party in any proceeding shall notify the Office of Workers' Compensation of their appearance by filing an entry of appearance or other appropriate pleading and shall be bound by Code of Civil Procedure Article 371.

AUTHORITY NOTE: Promulgated in accordance with R.S. 23:1310.1.

HISTORICAL NOTE: Promulgated by the Louisiana Department of Labor, Office of Workers' Compensation Administration, LR 25:267 (February 1999), amended LR 25:1861 (October 1999).

### §5547. Withdrawal of Counsel

A. When an attorney seeks to obtain an ex parte order to withdraw as counsel for a party, he shall include in his application the last known address of the claimant along with a statement that he has given written notice to the party he was previously representing that he is no longer of counsel to him and of the status of the case on the court's docket. The attorney shall certify to the court that he has given notice to all counsel of record at the same time and in the same manner as notification to the court. A copy of such written notice and certification shall be attached to the

application for the ex parte order for withdrawal. An attorney who has been permitted by ex parte order to withdraw shall give notice of same to all parties.

B. Counsel of record who withdraws or is discharged prior to submission of the case, and desires to assert a claim for fees, must attach an affidavit to that effect and set forth the period of time during which his client was under his or her representation. If asserting a claim, counsel shall also file a lien form, to be developed by the director, identifying any attorney lien he alleges on the pending claim for payment of attorney fees.

AUTHORITY NOTE: Promulgated in accordance with R.S. 23:1310.1.

HISTORICAL NOTE: Promulgated by the Department of Labor, Office of Workers' Compensation Administration, LR 25:267 (February 1999), amended LR 25:1862 (October 1999), LR 33:653 (April 2007).

## Chapter 57. Actions

### Subchapter A. General Provisions

#### §5701. Prescription; Filing Procedure

A. Prescription periods shall be as set forth in R.S. 23:1031.1.E, F, I, 1209, and 1234. Time limits shall be calculated from the date of mailing as shown by the post mark, other proof of mailing, the date a facsimile or electronic transmission (with verified signature) is received.

B. All pleadings filed with the court may be filed by facsimile transmission or electronic transmission (with verified signature) to the assigned facsimile number or electronic address of the district of proper venue. A facsimile or electronic transmission (with verified signature), when filed, has the same force and effect as the original. If the party fails to comply with the requirements of Paragraph C of this Section, a facsimile filing shall have no force or effect.

C.1. Within seven days, exclusive of legal holidays, after the district office or the records management division has received a facsimile transmission, the party filing the document shall forward the following to the district office or records manager:

- a. the original signed document;
- b. the applicable filing fee, if any per §6605, Fees, of this Part; and
- c. a transmission fee of \$5 in addition to \$5 for the first 5 pages and \$2.50 for each page thereafter.

D. Upon receipt in the office, the pleading or forms and any other correspondence shall be stamped with the date of receipt by the appropriate court personnel.

AUTHORITY NOTE: Promulgated in accordance with R.S. 23:1310.1.

HISTORICAL NOTE: Promulgated by the Department of Labor, Office of Workers' Compensation Administration, LR 25:267 (February 1999), amended LR 25:1862 (October 1999), LR 33:654 (April 2007), amended by the Louisiana Workforce

Commission, Office of Workers' Compensation, LR 37:1627 (June 2011), LR 46:798 (June 2020).

#### §5703. Prematurity

A. Prematurity in a workers' compensation claim shall be governed by R.S. 23:1314.

AUTHORITY NOTE: Promulgated in accordance with R.S. 23:1310.1.

HISTORICAL NOTE: Promulgated by the Louisiana Department of Labor, Office of Workers' Compensation Administration, LR 25:267 (February 1999), amended LR 25:1862 (October 1999).

#### §5705. Abandonment

A. A claim may be dismissed without prejudice after contradictory hearing properly noticed by the court on the judge's own motion or on ex parte motion of a party for the following reasons:

1. where no service of process has occurred within 60 days after the Form LWC-WC-1008 has been filed. This provision shall not apply if the claim is awaiting action by the workers' compensation court;
2. where no responsive pleadings have been filed and no default has been entered within 60 days after service of process;
3. where a claim has been pending six months without proceedings being taken within such period. This provision shall not apply if the claim is awaiting action by the workers' compensation court; or
4. where a claimant fails to appear for any properly noticed conference or hearing;
5. where an attorney or pro se litigant fails to keep the workers' compensation court apprised of an address change or when a notice is returned to the workers' compensation court for the reason of an incorrect address and no correction is made to the address for a period of 60 days.

B. Any formal discovery as authorized by these rules and served on all parties whether or not filed of record, including the taking of a deposition with or without formal notice, shall be deemed to be a step in the prosecution or defense of an action.

C. Any order of dismissal shall allow for reinstatement of the action within 30 days for good cause shown.

D. The workers' compensation judge may order the claim dismissed, with prejudice, after a contradictory hearing, when it is shown that more than 90 days has elapsed since a claim was dismissed for any reason listed in Subsection A of this Section and no good cause has been shown for reinstatement.

AUTHORITY NOTE: Promulgated in accordance with R.S. 23:1310.1.

HISTORICAL NOTE: Promulgated by the Department of Labor, Office of Workers' Compensation Administration, LR 25:268 (February 1999), amended LR 25:1862 (October 1999), LR 33:654 (April 2007), amended by the Louisiana Workforce Commission, Office of Workers' Compensation, LR 37:1627 (June 2011).

**§5707. Class Actions**

A. No class action will be permitted.

AUTHORITY NOTE: Promulgated in accordance with R.S. 23:1310.1.

HISTORICAL NOTE: Promulgated by the Louisiana Department of Labor, Office of workers' Compensation Administration, LR 25:268 (February 1999), amended LR 25:1862 (October 1999).

**Subchapter B. Settlement****§5709. Joint Petition Settlements**

A.1. A lump sum or compromise settlement shall be presented to the presiding judge in a pending disputed claim or to any judge in an undisputed claim for approval on Form LWC-WC-1011 and upon joint petition of the parties.

2. The procedure for perfecting settlements shall be governed by R.S. 23:1272. A hearing in open court with all parties present shall be required when one or more parties is not represented by counsel. Appearance by the parties and/or their representative may be waived if all parties are represented by counsel. In special circumstances and in the interest of judicial economy, the judge may allow the unrepresented party to waive his appearance and permit the party to appear by telephone. Appearance by the represented parties and/or their representative may be waived in written form.

B. When one or more parties is not represented by counsel, the judge may appoint an attorney to assist the court in determining whether the settlement does substantial justice and is in the best interest of all parties. In such cases the court may approve an attorney's fee to be paid out of the proceeds of the settlement.

AUTHORITY NOTE: Promulgated in accordance with R.S. 23:1310.1.

HISTORICAL NOTE: Promulgated by the Department of Labor, Office of Workers' Compensation Administration, LR 25:268 (February 1999), amended LR 25:1863 (October 1999), LR 33:654 (April 2007), amended by the Louisiana Workforce Commission, Office of Workers' Compensation, LR 37:1628 (June 2011).

**Chapter 58. Pleadings****Subchapter A. General****§5801. Pleadings Allowed**

A. The pleadings allowed in workers' compensation claims, whether in a principal or incidental action, shall be in writing and shall consist of petitions, exceptions, written motions, answers, and Office of Workers' Compensation Administration forms.

AUTHORITY NOTE: Promulgated in accordance with R.S. 23:1310.1.

HISTORICAL NOTE: Promulgated by the Louisiana Department of Labor, Office of Workers' Compensation Administration, LR 25:268 (February 1999), amended LR 25:1863 (October 1999).

**Subchapter B.  
Supplemental/Amended Pleadings****§5805. Amendment of Claim and Answer**

A. Amendment of a claim and answer shall be governed by Code of Civil Procedure Article 1151 et seq.

AUTHORITY NOTE: Promulgated in accordance with R.S. 23:1310.1.

HISTORICAL NOTE: Promulgated by the Louisiana Department of Labor, Office of Workers' Compensation Administration, LR 25:268 (February 1999), amended LR 25:1863 (October 1999), amended by the Louisiana Workforce Commission, Office of Workers' Compensation, LR 37:1628 (June 2011).

**Subchapter C. Forms****§5809. Forms**

A. The Office of Workers' Compensation Administration shall prepare and adopt such forms for use in matters before the Office of Workers' Compensation Administration as it may deem necessary or advisable. Whenever Office of Workers' Compensation Administration forms are prescribed and are applicable, they shall be used. A photo ready copy of any form may be procured upon request to any district office, the office of the director, or from the website, [www.laworks.net](http://www.laworks.net).

AUTHORITY NOTE: Promulgated in accordance with R.S. 23:1310.1.

HISTORICAL NOTE: Promulgated by the Department of Labor, Office of Workers' Compensation Administration, LR 25:269 (February 1999), amended LR 25:1863 (October 1999), LR 33:654 (April 2007), amended by the Louisiana Workforce Commission, Office of Workers' Compensation, LR 37:1628 (June 2011).

**§5811. Format of Documents**

A. Any pleading or other document submitted to the director or to any judge shall be typed or printed legibly on 8 1/2" x 11" paper and shall bear the name and signature of the person who prepared it, the firm name, if applicable, the complete address including the zip code, an electronic address, if available, the telephone and facsimile number, including the area code and the docket number, if one has been assigned to the claim and the name of the judge assigned to the claim, if available. All attorneys shall note their bar roll number on all documents and correspondence.

B. Copies of all correspondence and any other instruments sent to the Office of Workers' Compensation Administration shall be sent at the same time and in the same manner by the party originating the correspondence to all other parties of record in the case and a certificate to that effect shall be attached to the original and filed with the office.

C. All documents filed into the court record that are notarized shall comply with R.S. 35:12.

AUTHORITY NOTE: Promulgated in accordance with R.S. 23:1310.1.

HISTORICAL NOTE: Promulgated by the Department of Labor, Office of Workers' Compensation Administration, LR 25:269 (February 1999), amended LR 25:1863 (October 1999), LR 33:654 (April 2007).

## Subchapter D. Mediation

### §5813. Mediation Conference

A. Parties who have a workers' compensation dispute as defined by R.S. 23:1310.3(A) and who desire to engage the services of a Louisiana Workforce Commission, Office of Workers' Compensation Administration mediator, may make a joint written request for a mediation conference to any Office of Workers' Compensation mediator selected by mutual agreement of the parties. The parties shall forward to the selected mediator, along with the written request, a confidential position statement, not to exceed 10 pages, outlining the issues in dispute and the respective position of the parties. Upon receipt of the joint written request, the selected mediator shall schedule a mediation conference and provide notice in the same manner and at the same time to all parties of the date and time of the conference. Notice of any scheduled mediation conference may be given by telephone, but shall be confirmed by United States Mail, facsimile transmission, or electronic transmission. The location of the mediation conference shall be in the assigned district office of the selected mediator.

B. A mediation conference may also be scheduled upon order of a presiding workers' compensation judge in any pending workers' compensation disputed claim (Form LWC-WC-1008). If the parties select an Office of Workers' Compensation mediator, the court-ordered mediation conference shall be conducted in the district office in which the selected mediator is assigned.

C. On the scheduled date of the mediation conference, each party shall provide a representative to participate in the mediation conference, either in person or via telephone, who has been provided with authority to enter into negotiations in a good faith effort to resolve the issue(s) in dispute. The attorneys for the parties may participate in the mediation conference via telephone only upon mutual consent of the parties. No stenographic report shall be taken at any mediation conference and no witnesses shall be called. All statements made at any mediation conference shall be privileged and shall not be admissible in any subsequent status conference, pretrial conference, hearing, or trial. Any party to the claim and/or their representative may request a copy of the Form LWC-WC-1008 filed in the claim prior to the scheduled mediation conference. No such request shall be denied by any employee of the Office of Workers' Compensation Administration. If the parties agree, the mediator may schedule additional mediation conferences when deemed appropriate.

D. Nothing in this rule shall prohibit parties from requesting the services of an Office of Workers' Compensation mediator prior to the filing of a disputed claim for compensation (Form LWC-WC-1008). Said request shall be made by the parties in the same manner as provided for in Subsection A of this Section. However,

neither the request nor the participation in a pre-1008 mediation conference shall interrupt the running of prescription.

E. Nothing in this rule shall prohibit the parties from engaging the services of a private mediator to conduct a mediation conference at a location mutually agreeable to the parties. Within five days of the conclusion of said private mediation, the parties shall certify to the court that a private mediation has occurred and the results thereof. Said certification shall be provided by the parties via United States mail, electronic transmission, or facsimile transmission.

AUTHORITY NOTE: Promulgated in accordance with R.S. 23:1310.1.

HISTORICAL NOTE: Promulgated by the Department of Labor, Office of Workers' Compensation Administration, LR 25:1863 (October 1999), amended LR 33:654 (April 2007), amended by the Louisiana Workforce Commission, Office of Workers' Compensation, LR 37:1628 (June 2011).

### §5817. Conclusion of Mediation Conferences held by an Office of Workers' Compensation Mediator

A. When it becomes apparent during the course of a pre-1008 mediation conference that an agreement on all issues cannot be reached, the Office of Workers' Compensation mediator shall issue a report stating the result of the conference. The report shall be issued to the parties immediately following the conference by facsimile transmission, by electronic transmission or by mail within five days thereof.

B. When it becomes apparent during the course of a post-1008 mediation conference that agreement on all issues cannot be reached, the Office of Workers' Compensation mediator shall issue a report stating the results of the conference. The report shall be issued immediately following the conference to the parties and to the judge where the claim was filed. The report shall be issued in person, by facsimile transmission, by electronic transmission, or by mail within five days thereof.

C. Following a mediation conference, at which agreement is reached on all issues in dispute, a report embodying the agreement shall be issued to the parties in person, by facsimile transmission, by electronic transmission, or by mail within five days thereof. The mediator shall file the original report with the judge presiding over the district where the claim was filed or in the case of a pre-1008 mediation conference, with the judge presiding over the district situated within the parish of the claimant's domicile. The report may require dismissal of the claim or the filing of an LWC Form 1011 within 30 days.

AUTHORITY NOTE: Promulgated in accordance with R.S. 23:1310.1.

HISTORICAL NOTE: Promulgated by the Department of Labor, Office of Workers' Compensation Administration, LR 25:269 (February 1999), amended LR 25:1864 (October 1999), LR 33:655 (April 2007), amended by the Louisiana Workforce Commission, Office of Workers' Compensation, LR 37:1629 (June 2011).

**§5819. Failure to Attend; Sanctions**

A. If any party fails to appear at a mediation conference ordered by the judge or requested by the parties, after proper notice and without just cause, the presiding workers' compensation judge, upon request of a party, may fine the delinquent party an amount not to exceed \$500, which shall be payable to the Office of Workers' Compensation Administrative Fund. In addition, the presiding workers' compensation judge may assess against the party failing to attend, costs and reasonable attorney's fees incurred by any other party in connection with the conference. The penalties provided for in this Section shall be assessed by the presiding workers' compensation judge only after a contradictory hearing which shall be held prior to the hearing on the merits of the dispute.

AUTHORITY NOTE: Promulgated in accordance with R.S. 23:1310.1.

HISTORICAL NOTE: Promulgated by the Department of Labor, Office of Workers' Compensation Administration, LR 25:1864 (October 1999), amended LR 33:655 (April 2007), amended by the Louisiana Workforce Commission, Office of Workers' Compensation, LR 37:1629 (June 2011).

**Subchapter E. Petition****§5821. Required Elements**

A. The required elements of a workers' compensation claim shall be as provided in R.S. 23:1311.

AUTHORITY NOTE: Promulgated in accordance with R.S. 23:1310.1.

HISTORICAL NOTE: Promulgated by the Louisiana Department of Labor, Office of Workers' Compensation Administration, LR 25:270 (February 1999), amended LR 25:1865 (October 1999).

**Subchapter F. Exceptions****§5823. Kinds of Exceptions; Time for Pleading**

A. Exceptions shall be governed by Code of Civil Procedure Articles 921, et seq.

AUTHORITY NOTE: Promulgated in accordance with R.S. 23:1310.1.

HISTORICAL NOTE: Promulgated by the Louisiana Department of Labor, Office of Workers' Compensation Administration, LR 25:270 (February 1999), amended LR 25:1865 (October 1999).

**§5824. Rule to Show Cause; Time for Filing Memoranda**

A. Any party may seek to have any exception heard by filing a rule to show cause.

B. The memorandum in support shall be filed no later than 14 days prior to the hearing. The memorandum in opposition shall be filed no later than 8 days prior to the hearing.

AUTHORITY NOTE: Promulgated in accordance with R.S. 23:1310.1.

HISTORICAL NOTE: Promulgated by the Department of Labor, Office of Workers' Compensation Administration, LR 33:656 (April 2007).

**Subchapter G. Motions****§5831. Motion or Rule Day**

A. Each district office shall designate a specific day of the week for the hearing of rules, motions, exceptions and arguments. A list of the rule days for each district shall be available in any district office.

B. The judge may require the parties to submit briefs in connection with any exception, rule, or motion. Briefs should be submitted as provided in §5824. A copy of the brief shall be served upon all counsel of record at the same time and in the same manner as submitted to the court.

C. In advance of the date set for the hearing of an exception, motion or rule, any counsel may notify the court that he waives his appearance and is willing to submit the matter on briefs. At the time set for the hearing, any person may waive oral argument.

D. A motion for summary judgment shall be filed no later than 45 days prior to trial unless both parties agree to waive the deadline with the approval of the court.

AUTHORITY NOTE: Promulgated in accordance with R.S. 23:1310.1.

HISTORICAL NOTE: Promulgated by the Department of Labor, Office of Workers' Compensation Administration, LR 25:270 (February 1999), amended LR 25:1865 (October 1999), LR 33:656 (April 2007).

**§5833. Written Motion Required; Exception**

A. An application to the court for an order, if not presented in some other pleading, shall be by motion which, unless made during trial or hearing or in open court, shall be in writing. The written motion shall state the grounds therefor and the relief or order sought.

AUTHORITY NOTE: Promulgated in accordance with R.S. 23:1310.1.

HISTORICAL NOTE: Promulgated by the Louisiana Department of Labor, Office of Workers' Compensation Administration, LR 25:270 (February 1999), amended LR 25:1865 (October 1999).

**§5835. Ex Parte and Contradictory Motions; Rule to Show Cause Favored**

A. Ex parte and contradictory motions shall be governed by Code of Civil Procedure Articles 963 et seq. A contradictory hearing properly noticed by the court with the adverse party may be held unless waived upon joint motion of the parties. Appearance by the parties and/or their representative may be waived in written form. The judge may entertain such motion by telephone conference with all parties participating. Such telephone conference shall be initiated by the party requesting the telephone conference.

AUTHORITY NOTE: Promulgated in accordance with R.S. 23:1310.1.

HISTORICAL NOTE: Promulgated by the Department of Labor, Office of Workers' Compensation Administration, LR 25:270 (February 1999), amended LR 25:1865 (October 1999), LR 33:656 (April 2007).

## Chapter 59. Production of Evidence

### Subchapter A. General

#### §5901. Discovery and Attendance of Witnesses

A. The hearing process shall be available to aid any party in pursuit of discovery and to compel attendance of witnesses or production of evidence. The judge on his own motion at any conference may order the production of discoverable material and make any other order facilitating discovery. Copies of discovery documents, including, but not limited to, deposition notices, are to be mailed to all parties and shall not be filed in the record of the proceedings unless attached as an exhibit to a motion or ordered by the judge.

AUTHORITY NOTE: Promulgated in accordance with R.S. 23:1310.1.

HISTORICAL NOTE: Promulgated by the Department of Labor, Office of Workers' Compensation Administration, LR 25:271 (February 1999), amended LR 25:1865 (October 1999), LR 33:656 (April 2007).

#### §5903. Objections to Evidence

A. Except as otherwise provided in Title 23 or by these rules, objection to any evidence shall be governed by the Louisiana Code of Evidence and Code of Civil Procedure.

AUTHORITY NOTE: Promulgated in accordance with R.S. 23:1310.1.

HISTORICAL NOTE: Promulgated by the Louisiana Department of Labor, Office of Workers' Compensation Administration, LR 25:272 (February 1999), amended LR 25:1865 (October 1999).

#### §5905. Protective Orders

A. Upon motion by a party or by a person from whom discovery is sought, and for good cause shown after contradictory hearing properly noticed by the court, the judge may make any order which justice requires to protect a party or person from annoyance, embarrassment, oppression, or undue burden or expense. The judge may entertain such motion by telephone conference with all necessary parties participating. Such telephone conference shall be initiated by the party requesting the telephone conference.

AUTHORITY NOTE: Promulgated in accordance with R.S. 23:1310.1.

HISTORICAL NOTE: Promulgated by the Department of Labor, Office of Workers' Compensation Administration, LR 25:272 (February 1999), amended LR 25:1865 (October 1999), LR 33:656 (April 2007).

### Subchapter B. Subpoena

#### §5909. Issuance; Service

A. Subpoenas issued in connection with any workers' compensation matter shall be served by the party requesting issuance of the subpoena, and may be served by certified mail return receipt requested or any other manner provided in §5511. Proof of service shall be the responsibility of the party requesting the subpoena. Once issued and served, a subpoena may be canceled by the requesting party only after

written notice to the opposing side. It shall be the responsibility of the requesting party to provide written notification of cancellation to all opposing parties as well as the person under subpoena. It shall be the responsibility of the parties to copy each other on the subpoenas they issue.

B. In order to be enforceable, subpoenas for hearing shall be served seven days prior to the scheduled hearing date; subpoenas to compel attendance of medical experts shall be served 10 days prior to hearing. Subpoenas for hearing may be issued after expiration of these time limits only by leave of court for good cause shown or upon written consent of all parties.

C. Written request for unemployment records must be made to the workers' compensation court at least seven days prior to the scheduled hearing at which the documents sought are to be submitted.

AUTHORITY NOTE: Promulgated in accordance with R.S. 23:1310.1.

HISTORICAL NOTE: Promulgated by the Department of Labor, Office of Workers' Compensation Administration, LR 25:272 (February 1999), amended LR 25:1866 (October 1999), LR 33:656 (April 2007).

#### §5911. Exceptions

A. No official of the Social Security Administration shall be subject to subpoena under these rules except for good cause shown.

B. An independent medical examiner shall be subject to subpoena only as provided in R.S. 23:1317.1.

C. The subpoena of the director or any other employee of the Office of Workers' Compensation Administration shall be governed by R.S. 23:1318.

AUTHORITY NOTE: Promulgated in accordance with R.S. 23:1310.1.

HISTORICAL NOTE: Promulgated by the Louisiana Department of Labor, Office of Workers' Compensation Administration, LR 25:272 (February 1999), amended LR 25:1866 (October 1999).

#### §5913. Subpoena of Confidential Records

A. The subpoena of confidential records shall be governed by R.S. 23:1293.A.(1) and 1310.15.

AUTHORITY NOTE: Promulgated in accordance with R.S. 23:1310.1.

HISTORICAL NOTE: Promulgated by the Louisiana Department of Labor, Office of Workers' Compensation Administration, LR 25:272 (February 1999), amended LR 25:1866 (October 1999).

### Subchapter C. Discovery

#### §5915. Scope of Discovery

A. Discovery shall be governed by Code of Civil Procedure Articles 1421, et seq.

AUTHORITY NOTE: Promulgated in accordance with R.S. 23:1310.1.

HISTORICAL NOTE: Promulgated by the Louisiana Department of Labor, Office of Workers' Compensation

Administration, LR 25:272 (February 1999), amended LR 25:1866 (October 1999).

## Subchapter D. Depositions

### §5921. General; When Taken

A. The taking of a deposition shall be governed by Code of Civil Procedure Articles 1437, et seq.

AUTHORITY NOTE: Promulgated in accordance with R.S. 23:1310.1.

HISTORICAL NOTE: Promulgated by the Louisiana Department of Labor, Office of Workers' Compensation Administration, LR 25:273 (February 1999), amended LR 25:1866 (October 1999).

### §5925. Depositions in Advance of Hearing; Perpetuation of Testimony

A. Depositions in advance of hearing shall be governed by R.S. 23:1319.

B. Any party seeking to offer the testimony of a witness at trial by deposition may take a deposition to perpetuate the trial testimony of such witness at any time prior to trial. Such deposition may be offered by any party and shall be admissible upon consent of the parties or as otherwise provided by these rules, the Code of Evidence and the Code of Civil Procedure.

AUTHORITY NOTE: Promulgated in accordance with R.S. 23:1310.1.

HISTORICAL NOTE: Promulgated by the Louisiana Department of Labor, Office of Workers' Compensation Administration, LR 25:273 (February 1999), amended LR 25:1866 (October 1999), amended by the Louisiana Workforce Commission, Office of Workers' Compensation, LR 37:1629 (June 2011).

### §5927. Expert Witness Fee

A. For just cause shown, the workers' compensation judge may set a reasonable witness fee for expert testimony.

AUTHORITY NOTE: Promulgated in accordance with R.S. 23:1310.1.

HISTORICAL NOTE: Promulgated by the Department of Labor, Office of Workers' Compensation Administration, LR 33:657 (April 2007).

## Subchapter E. Interrogatories

### §5931. General

A. Interrogatories shall be governed by Code of Civil Procedure Articles 1457, et seq.

AUTHORITY NOTE: Promulgated in accordance with R.S. 23:1310.1.

HISTORICAL NOTE: Promulgated by the Louisiana Department of Labor, Office of Workers' Compensation Administration, LR 25:274 (February 1999), amended LR 25:1866 (October 1999).

## Subchapter F. Production of Documents

### §5933. Production of Documents; General; Medical Evidence

A. In general, the production of documents shall be governed by Code of Civil Procedure Articles 1461, et seq. and R.S. 23:1127.

B. Objection to medical evidence shall be as provided in R.S. 23:1122. When a timely objection is received, the judge may set a hearing on the motion, or rule on the matter at the trial on the merits. The judge further has the discretion to order, after a contradictory hearing properly noticed by the court, a deposition of the doctor if necessary to clarify a report or to obtain additional information, during the discovery period or at the trial on the merits.

AUTHORITY NOTE: Promulgated in accordance with R.S. 23:1310.1.

HISTORICAL NOTE: Promulgated by the Department of Labor, Office of Workers' Compensation Administration, LR 25:274 (February 1999), amended LR 25:1866 (October 1999), LR 33:657 (April 2007).

## Subchapter G. Admissions

### §5941. Requests for Admission

A. Requests for admission shall be governed by Code of Civil Procedure Articles 1466, et seq.

AUTHORITY NOTE: Promulgated in accordance with R.S. 23:1310.1.

HISTORICAL NOTE: Promulgated by the Louisiana Department of Labor, Office of Workers' Compensation Administration, LR 25:275 (February 1999), amended LR 25:1867 (October 1999).

## Subchapter H. Medical Examinations

### §5943. Independent Medical Examinations; Report; Deposition of Examiner; Objections

A. The procedure for requesting an independent medical examination shall be as provided in R.S. 23:1317.1.

B. Objections to the independent medical examination shall be made on Form LDOL-WC-1008 and shall be set for hearing before a judge within 30 days of receipt. No mediation shall be scheduled on disputes arising under this Section.

AUTHORITY NOTE: Promulgated in accordance with R.S. 23:1310.1.

HISTORICAL NOTE: Promulgated by the Louisiana Department of Labor, Office of Workers' Compensation Administration, LR 25:275 (February 1999), amended LR 25:1867 (October 1999).

### §5953. Right of an Employee to Written Report of Medical Examination

A. Entitlement of an employee to the written report of a medical examination shall be as provided in R.S. 23:1125.

AUTHORITY NOTE: Promulgated in accordance with R.S. 23:1310.1.

HISTORICAL NOTE: Promulgated by the Louisiana Department of Labor, Office of Workers' Compensation Administration, LR 25:1867 (October 1999).

## Subchapter I. Motion to Compel

### §5955. Motion for Order Compelling Discovery

A. Motion for order compelling discovery shall be governed by Code of Civil Procedure Articles 1469, et seq., and R.S. 13:3715.1 and §5963.

B. Prior to filing a motion to compel discovery, a party shall comply with Rule 10.1 of the Rules for Louisiana District Courts adopted by the Louisiana Supreme Court.

AUTHORITY NOTE: Promulgated in accordance with R.S. 23:1310.1.

HISTORICAL NOTE: Promulgated by the Department of Labor, Office of Workers' Compensation Administration, LR 25:275 (February 1999), amended LR 25:1867 (October 1999), LR 33:657 (April 2007).

## Subchapter J. Sanctions

### §5961. Refusal to Obey Subpoena

A. When a person who, without reasonable excuse, fails to obey a subpoena, the judge may proceed with contempt proceedings as provided in R.S. 23:1310.7.

AUTHORITY NOTE: Promulgated in accordance with R.S. 23:1310.1.

HISTORICAL NOTE: Promulgated by the Department of Labor, Office of Workers' Compensation Administration, LR 25:276 (February 1999), amended LR 25:1867 (October 1999), LR 33:657 (April 2007).

### §5963. Failure to Comply with Order Compelling Discovery

A. Failure to comply with order compelling discovery shall be governed by Code of Civil Procedure Article 1471. In addition, the judge may proceed with contempt proceedings as provided in R.S. 23:1310.7.

AUTHORITY NOTE: Promulgated in accordance with R.S. 23:1310.1.

HISTORICAL NOTE: Promulgated by the Department of Labor, Office of Workers' Compensation Administration, LR 25:276 (February 1999), amended LR 25:1867 (October 1999), LR 33:657 (April 2007).

## Chapter 60. Pretrial Procedure

### §6001. Scheduling Conferences

A. Within 60 days following receipt of the answer a scheduling conference for the purpose of setting pretrial deadlines shall be held by telephone.

B. Issues to be considered and determined at the scheduling conference may include:

1. the necessity or desirability of amendments to pleadings;
2. discovery anticipated by the parties;

3. deadlines for amendments to pleadings; completion of discovery and scheduling of pretrial motions;

4. scheduling of the pretrial conference and the scheduling of a pretrial mediation conference;

5. scheduling of the trial;

6. the need for and scheduling of a pretrial conference;

7. such other matters as may aid in the disposition of the action.

C. At the conclusion of the scheduling conference and no longer than 14 days following the conference, a scheduling order, developed by the director, shall be issued by the judge setting forth the actions taken and deadlines set at the conference. Such order shall control the subsequent course of the claim, unless modified to prevent manifest injustice upon motion of a party or by order of the court.

D. The judge in his discretion may require a pretrial conference to be held by telephone.

E. The trial date should not be more than six months from the scheduling conference.

F. If the parties agree, discovery may be conducted after the date set in the scheduling order for the completion of discovery and the parties shall notify the court.

AUTHORITY NOTE: Promulgated in accordance with R.S. 23:1310.1.

HISTORICAL NOTE: Promulgated by the Department of Labor, Office of Workers' Compensation Administration, LR 25:1867 (October 1999), amended LR 33:657 (April 2007), amended by the Louisiana Workforce Commission, Office of Workers' Compensation, LR 37:1629 (June 2011).

### §6005. Pretrial Conference

A. When requested by the court, each party to the dispute shall file a pretrial statement with the appropriate district office within the time frame designated by the court.

B. The party or counsel who prepared and submitted the pretrial statement to the workers' compensation court should attend the pretrial conference. Any substitute permitted by the court to attend the conference shall be knowledgeable of all aspects of the case and shall possess the necessary authority to commit his client or associate regarding changes, stipulations, compromise/settlements, and trial dates.

C. The pretrial conference will be held by telephone, unless in the judge's discretion, attendance in person at the conference is necessary.

AUTHORITY NOTE: Promulgated in accordance with R.S. 23:1310.1.

HISTORICAL NOTE: Promulgated by the Department of Labor, Office of Workers' Compensation Administration, LR 25:277 (February 1999), amended LR 25:1868 (October 1999), LR 33:657 (April 2007), amended by the Louisiana Workforce Commission, Office of Workers' Compensation, LR 37:1629 (June 2011).



**§6007. Pretrial Order**

A. The pretrial statement shall include:

1. stipulations agreed to by all parties;
2. issues to be litigated;
3. contentions;
4. a list and brief description of all exhibits to be offered at trial; Exhibits to be used for impeachment or rebuttal need not be included in the list. Proposed stipulations as to exhibit authenticity and/or admissibility shall be noted in the exhibit list;
5. a list of all witnesses to be called at trial. The list shall include a short statement as to the nature but not the content of their testimony, and whether the testimony will be live or by deposition. Except for the witnesses listed, no other witnesses may be called to testify except for good cause shown. This requirement shall not apply to impeachment and rebuttal witnesses;
6. outstanding discovery and depositions to be taken.

B. Amendments to the pretrial statement shall only be by written motion and permitted only for good cause shown. No new issues shall be raised except by written order of the judge for good cause or upon mutual agreement of the parties.

AUTHORITY NOTE: Promulgated in accordance with R.S. 23:1310.1.

HISTORICAL NOTE: Promulgated by the Department of Labor, Office of Workers' Compensation Administration, LR 25:277 (February 1999), amended LR 25:1868 (October 1999), LR 33:657 (April 2007).

**Chapter 61. Hearings****Subchapter A. Expedited Hearings****§6101. Examination of an Injured Employee**

A. The examination of an injured employee shall be governed by R.S. 23:1124.1.

AUTHORITY NOTE: Promulgated in accordance with R.S. 23:1310.1.

HISTORICAL NOTE: Promulgated by the Department of Labor, Office of Workers' Compensation Administration, LR 25:1868 (October 1999), amended LR 33:658 (April 2007).

**Subchapter B. Continuance and Stays****§6103. General**

A. Continuances shall be as provided in Code of Civil Procedure Articles 1601, et seq.

B. A continuance shall not be granted for the absence of a subpoenaed witness if the subpoena was not issued in accordance with §5909 of these rules.

C. A continuance will not be entertained based upon a conflict in the schedule of any party or attorney if the conflict arose after the date of the scheduling conference,

except for good cause shown or in cases of criminal assignments.

D.1. If all parties are represented by counsel and the motion is uncontested, the moving party shall certify to the court that he has spoken to opposing counsel, that no opposition exists and that all witnesses have been timely notified of the continuance. Only one uncontested motion must be granted. A new trial date shall be established by mutual agreement of the parties.

2. Subsequent uncontested motions for continuance by represented parties may be granted at the discretion of the workers' compensation judge and when the workers' compensation judge believes it is in the best interest of the parties.

E. If any of the parties are unrepresented, the uncontested motion may be granted if there are good grounds therefore and if the workers' compensation judge believes it is in the best interest of the parties.

F. The request for continuance shall state the reasons the continuance is necessary, that all parties have been notified of the request, and whether all parties agree to the continuance.

G. Joint requests for continuance of a pre-1008 or post-1008 mediation conference held by an Office of Workers' Compensation mediator shall be submitted to the selected mediator in writing.

H. Joint requests for continuance of a court-ordered mediation conference may be permitted for good cause shown by written motion to the judge where the claim was filed no later than three business days prior to the scheduled conference. The request shall state the reasons why the continuance is necessary, that all parties have been notified of the request and that all parties agree to the continuance.

I. Contradictory motions for continuance of a court-ordered mediation conference shall be submitted by written motion to the judge where the claim was filed no later than five business days prior to the scheduled mediation. The judge may entertain such motion by telephone status conference with all parties participating. Such telephone status conference shall be initiated by the party requesting the continuance.

AUTHORITY NOTE: Promulgated in accordance with R.S. 23:1310.1.

HISTORICAL NOTE: Promulgated by the Department of Labor, Office of Workers' Compensation Administration, LR 25:277 (February 1999), amended LR 25:1868 (October 1999), LR 33:658 (April 2007), amended by the Louisiana Workforce Commission, Office of Workers' Compensation, LR 37:1630 (June 2011).

**§6104. Stays**

A. Upon motion of a party and for good cause shown, or at the discretion of the court in the interest of justice, the workers' compensation judge may order a stay of the claim.

B. When a stay is granted, a telephone status conference shall be set at such intervals as directed by the workers' compensation judge but at least every six months.

C. Section 5705.A of these rules shall not apply to any matter subject to a stay order as long as such order is in effect.

AUTHORITY NOTE: Promulgated in accordance with R.S. 23:1310.1.

HISTORICAL NOTE: Promulgated by the Louisiana Workforce Commission, Office of Workers' Compensation Administration, LR 37:1630 (June 2011).

## Chapter 62. Trial

### Subchapter A. Trial Procedure

#### §6203. Trial on the Merits

A. The trial of a workers' compensation claim shall be governed by R.S. 23:1317.

AUTHORITY NOTE: Promulgated in accordance with R.S. 23:1310.1.

HISTORICAL NOTE: Promulgated by the Louisiana Department of Labor, Office of Workers' Compensation Administration, LR 25:1869 (October 1999).

#### §6205. Cumulative Medical Testimony

A. The introduction of medical testimony in a hearing or trial shall be governed by R.S. 23:1124.1.

AUTHORITY NOTE: Promulgated in accordance with R.S. 23:1310.1.

HISTORICAL NOTE: Promulgated by the Louisiana Department of Labor, Office of Workers' Compensation Administration, LR 25:278 (February 1999), amended LR 25:1869 (October 1999).

#### §6209. Testimony of Medical Personnel

A. Expert medical testimony may be admitted by:

1. certified medical records;
2. deposition;
3. oral examination in open court proceedings; however, no more than two physicians may present testimony for either party except by order of the judge;
4. any other manner provided by law.

AUTHORITY NOTE: Promulgated in accordance with R.S. 23:1310.1.

HISTORICAL NOTE: Promulgated by the Department of Labor, Office of Workers' Compensation Administration, LR 25:278 (February 1999), amended LR 25:1869 (October 1999), LR 33:658 (April 2007).

### Subchapter B. Dismissal

#### §6211. Dismissal

A. Except as provided in §5705, dismissals shall be governed by Code of Civil Procedure Articles 1671 et seq.

AUTHORITY NOTE: Promulgated in accordance with R.S. 23:1310.1.

HISTORICAL NOTE: Promulgated by the Department of Labor, Office of Workers' Compensation Administration, LR 25:278 (February 1999), amended LR 25:1869 (October 1999), LR 33:658 (April 2007).

## Subchapter C. Assessment of Costs

### §6215. Assessment of Costs

A. The determination of whether costs shall be assessed against a party shall be governed by R.S. 23:1310.9.

AUTHORITY NOTE: Promulgated in accordance with R.S. 23:1310.1.

HISTORICAL NOTE: Promulgated by the Louisiana Department of Labor, Office of Workers' Compensation Administration, LR 25:279 (February 1999), amended LR 25:1869 (October 1999).

## Chapter 63. Judgments

### Subchapter A. General

#### §6301. Submission of Evidence Submission for Judgement/Decision; Post Hearing Briefs

A. The parties shall file into the record all evidence at the time of trial or hearing unless the court, for good cause shown, grants an extension.

B. A case or other matter shall be considered as having been fully submitted for decision immediately upon the conclusion of trial or hearing or final submission of all evidence or post-trial/hearing briefs, whichever occurs latest.

C. Whenever, the judge allows or orders post-trial/hearing briefs, the parties shall be allowed a maximum of 15 working days from the conclusion of the trial or final submission of all evidence, whichever occurs latest, to file the briefs.

D. The brief must be received in the district office either through the United States Postal Service, facsimile transmission, or electronic transmission (with verified signature) within the delays provided and without benefit of the use of the postmark to meet the deadline.

AUTHORITY NOTE: Promulgated in accordance with R.S. 23:1310.1.

HISTORICAL NOTE: Promulgated by the Department of Labor, Office of Workers' Compensation Administration, LR 25:279 (February 1999), amended LR 25:1869 (October 1999), LR 33:658 (April 2007).

#### §6303. Completion of Trial; Pronouncement of Judgment; Time for Judgments or Orders; Written Reasons

A. The procedures for completion of trial and pronouncement of judgment shall be governed by R.S. 23:1310.5.A.(1) and 1201.3.A. All such orders, decisions, or awards shall be rendered no later than 45 calendar days after conclusion of trial, submission of all evidence or filing of post-trial/hearing briefs, whichever occurs later.

B. Written reasons shall only be rendered if requested in written form by any party to the claim within 10 days of the signing of the judgment. The written reasons shall be issued

by the judge not later than 45 calendar days following the request.

C. After the submission of all evidence oral rulings may be issued from the bench immediately after the trial or subsequent to the trial. In either case, the oral ruling shall be made by recitation of the reasons for judgment in open court and capable of being transcribed from the record of the proceeding. The transcript of the oral reasons for judgment may be considered the written reasons for judgment.

AUTHORITY NOTE: Promulgated in accordance with R.S. 23:1310.1.

HISTORICAL NOTE: Promulgated by the Department of Labor, Office of Workers' Compensation Administration, LR 25:279 (February 1999), amended LR 25:1869 (October 1999), LR 33:658 (April 2007).

## Subchapter B. Default

### §6305. Default; General Provisions; Scope of Judgment

A. The general rule regarding default in a workers' compensation claim shall be governed by R.S. 23:1316 and 1316.1 and Code of Civil Procedure Article 1703.

AUTHORITY NOTE: Promulgated in accordance with R.S. 23:1310.1.

HISTORICAL NOTE: Promulgated by the Louisiana Department of Labor, Office of Workers' Compensation Administration, LR 25:279 (February 1999), amended LR 25:1870 (October 1999).

## Subchapter C. Modification

### §6311. General

A. The modification of an award shall be governed by R.S. 23:1310.8(A)(1), (B) and (F).

AUTHORITY NOTE: Promulgated in accordance with R.S. 23:1310.1.

HISTORICAL NOTE: Promulgated by the Department of Labor, Office of Workers' Compensation Administration, LR 25:279 (February 1999), amended LR 25:1870 (October 1999), LR 33:659 (April 2007).

### §6313. Amendment of Judgment

A. Amendments of judgment shall be governed by Code of Civil Procedure Article 1951.

AUTHORITY NOTE: Promulgated in accordance with R.S. 23:1310.1.

HISTORICAL NOTE: Promulgated by the Louisiana Department of Labor, Office of Workers' Compensation Administration, LR 25:279 (February 1999), amended LR 25:1870 (October 1999).

### §6315. Request for Modification

A. Any party to the claim may apply for modification pursuant to §6311. If the original decision or award was made by a district court judge, the party seeking the modification shall furnish the workers' compensation judge with the appropriate evidence and documents from the district proceedings.

AUTHORITY NOTE: Promulgated in accordance with R.S. 23:1310.1.

HISTORICAL NOTE: Promulgated by the Department of Labor, Office of Workers' Compensation Administration, LR 25:279 (February 1999), amended LR 25:1870 (October 1999), LR 33:659 (April 2007).

### §6317. Exception

A. A motion for new trial shall be governed by Code of Civil Procedure Articles 1971 et seq.

AUTHORITY NOTE: Promulgated in accordance with R.S. 23:1310.1.

HISTORICAL NOTE: Promulgated by the Department of Labor, Office of Workers' Compensation Administration, LR 25:279 (February 1999), amended LR 25:1870 (October 1999), LR 33:659 (April 2007).

## Chapter 64. Appellate Procedure

### Subchapter A. General

#### §6401. General

A. All appeals shall be taken in accordance with the procedures set forth in R.S. 23:1310.5 and, where not in conflict, the Louisiana Code of Civil Procedure and the relevant rules of the appropriate circuit court of appeal.

AUTHORITY NOTE: Promulgated in accordance with R.S. 23:1310.1.

HISTORICAL NOTE: Promulgated by the Louisiana Department of Labor, Office of Workers' Compensation Administration, LR 25:279 (February 1999), amended LR 25:1870 (October 1999).

#### §6405. Payment of Appellate Costs

A. Payment of appellate costs shall be governed by Code of Civil Procedure Articles 2126, et seq.

AUTHORITY NOTE: Promulgated in accordance with R.S. 23:1310.1.

HISTORICAL NOTE: Promulgated by the Louisiana Department of Labor, Office of Workers' Compensation Administration, LR 25:279 (February 1999), amended LR 25:1870 (October 1999).

## Chapter 65. Special Disputes

### Subchapter A. Attorney Fees

#### §6501. Disputed Attorney Fees

A. When a dispute arises among several attorneys as to the identity of claimant's counsel of record, or when several successive attorneys lay claim to a fee in the same case, the judge shall decide the issues raised and allocate the fee allowed in accordance with Rule 1.5 of the Rules of Professional Conduct of the Louisiana Supreme Court.

AUTHORITY NOTE: Promulgated in accordance with R.S. 23:1310.1.

HISTORICAL NOTE: Promulgated by the Department of Labor, Office of Workers' Compensation Administration, LR 25:280 (February 1999), amended LR 25:1870 (October 1999), LR 33:659 (April 2007).

**§6503. Attorney Fees; Application, Review and Approval**

A. Whenever the judge renders an award of penalties or attorney fees due to the conduct of the other party under any provision authorized by the Workers' Compensation Act, the judgment shall state the specific acts or omissions of the party which gave rise to the award of a penalty or attorney fee. When attorney fees are awarded due to the conduct of a party the judgment shall state the basis for the amount of the award.

B. Attorney fee claims under R.S. 23:1141 for allowable portions of periodic payments of indemnity benefits recovered by claimants shall only be authorized after approval by the presiding judge upon filing of a motion for such fees filed by the claimant's attorney.

AUTHORITY NOTE: Promulgated in accordance with R.S. 23:1310.1.

HISTORICAL NOTE: Promulgated by the Louisiana Department of Labor, Office of Workers' Compensation Administration, LR 25:281 (February 1999), amended LR 25:1870 (October 1999).

**§6505. Reserved.**

**Subchapter B. Social Security Offset****§6507. Offset**

A. A request for offsets pursuant to R.S. 23:1225(C) made in connection with a disputed claim shall be made by filing Form LDOL-WC-1008 or by responsive pleading. An order shall be issued recognizing the entitlement to the offset for social security benefits from the date of judicial demand, and setting the amount of the offset after a determination of the character of the disability, the right to the offset, and calculation of the offset. A contradictory hearing properly noticed by the court may be set by the judge for this determination. Notice shall be provided to the claimant or his representative prior to issuance of the order. The order shall be served by certified mail upon all parties and the Social Security Administration. Such offsets may be taken upon receipt of proof of service of the order upon the Social Security Administration by the Office of Workers' Compensation Administration. Such offsets shall not be taken unless the social security offset has been removed.

B. A request for offsets pursuant to R.S. 23:1225(A) made in connection with a claim not in dispute may be made by motion on Form LWC-WC-1005(A) or by letter, filed in the appropriate district office. When properly filed, the motion or letter requesting an offset may be granted ex parte from date of filing. Such offsets shall not be taken unless the social security offset has been removed. No fee shall be charged in connection with a request made under this Subsection.

C. A unilateral reverse offset shall not be recognized by this office after March 20, 1993. A unilateral offset under any other Subsection of R.S. 23:1225 shall not be recognized by this office after January 1, 2000.

D. Information concerning receipt of Social Security benefits and the amounts thereof shall be obtained on Form LDOL-WC-1004, which shall be properly executed by an official designated by the Social Security Administration.

E. An official of the Social Security Administration shall not be subject to subpoena under this rule unless for good cause shown.

AUTHORITY NOTE: Promulgated in accordance with R.S. 23:1310.1.

HISTORICAL NOTE: Promulgated by the Department of Labor, Office of Workers' Compensation Administration, LR 25:281 (February 1999), amended LR 25:1871 (October 1999), LR 33:659 (April 2007), amended by the Louisiana Workforce Commission, Office of Workers' Compensation, LR 37:1630 (June 2011).

**Subchapter C. Financial and Compliance Hearings****§6509. Financial and Compliance Hearings**

A. Any party may request a mediation conference which shall be held within 15 days of the filing of an appeal for financial and compliance matters.

B. If a resolution is not reached, a hearing on the appeal held pursuant to R.S. 23:1171 shall be held within 15 days of the conclusion of the initial mediation conference, and shall be conducted in accordance with the provisions of the Administrative Procedure Act.

C. Suspensive appeals of a determination of the financial and compliance officer will not be entertained.

AUTHORITY NOTE: Promulgated in accordance with R.S. 23:1310.1.

HISTORICAL NOTE: Promulgated by the Department of Labor, Office of Workers' Compensation Administration, LR 25:281 (February 1999), amended LR 25:1871 (October 1999), LR 33:659 (April 2007), amended by the Louisiana Workforce Commission, Office of Workers' Compensation, LR 37:1630 (June 2011).

**Chapter 66. Miscellaneous****Subchapter A. General****§6601. Other Applicable Rules**

A. Unless otherwise provided for in these rules, any practice or procedure not in conflict with either the Workers' Compensation Act or these rules will be guided by practice and procedure provided for in the Louisiana Code of Civil Procedure.

AUTHORITY NOTE: Promulgated in accordance with R.S. 23:1310.1.

HISTORICAL NOTE: Promulgated by the Department of Labor, Office of Workers' Compensation Administration, LR 25:281 (February 1999), amended LR 25:1871 (October 1999).

**§6603. Local Rules Prohibited**

A. Local rules by any district office of the Office of Workers' Compensation Administration are prohibited.

AUTHORITY NOTE: Promulgated in accordance with R.S. 23:1310.1.

HISTORICAL NOTE: Promulgated by the Louisiana Department of Labor, Office of Workers' Compensation Administration, LR 25:281 (February 1999), amended LR 25:1871 (October 1999).

### §6605. Fees

A. The clerks for the Office of Workers' Compensation Administration shall be entitled to demand and receive the following fees as court costs in a workers' compensation dispute. Fees not pre-paid shall be due upon dismissal of or final judgment in the docket number, or on demand by the clerk:

1. filing of LWC-WC-1008—\$50;
2. filing of LWC-WC-1011 when no LWC-WC-1008 for the same parties, same accident, and same issue(s) is pending—\$50;
3. service of process on secretary of state—\$50 or as otherwise set by the secretary of state;
4. copies of any paper in any suit record—\$0.25 per page;
5. for each certification—\$1 per page;
6. filing by facsimile or electronic transmission—\$5 transmission fee per hearing rule, §5701.C.1.c, in addition to \$5 for the first 5 pages and \$2.50 for each page thereafter;
7. cost of preparation of record for appeal—available upon request from the district offices;
8. cost of service by certified mail—\$8 per service;
9. subpoenas/subpoenas *duces tecum*—\$5;
10. privilege of litigating without prior payment of costs.

a. If a requestor is unable to pay the costs of court in advance because of his or her poverty and lack of means, the requestor shall fully execute an *in forma pauperis* request on the LWC request for waiver of advance costs form, and file the form with the Office of Workers' Compensation Administration. If the form is deemed proper and the relief sought appropriate, a workers' compensation judge shall execute the pauper order, and the filing fee will not be due in advance or as they accrue. If the request is denied by a workers' compensation judge, all costs shall be pre-paid in full before any documents may be filed.

b. In the event any person seeks to prosecute a suit in a workers' compensation court while incarcerated or imprisoned for the commission of a felony without paying the costs in advance as they accrue or furnishing security thereof, the court shall require such person to advance costs in accordance with *Louisiana Code of Civil Procedure*, article 5181(B) and (C).

B. The Office of Workers' Compensation Administration shall be entitled to demand and receive the following fees which shall be pre-paid in full before any records are

produced, unless otherwise ordered by a workers' compensation judge or otherwise provided by law:

1. record request—\$25 per request per docket number;
2. certification fee—\$25 per request per docket number;
3. if a requestor is indigent and seeks to have the fee waived, the requestor shall fully execute an *in forma pauperis* request on the LWC request for waiver of advance costs form, and file the form with the Office of Workers' Compensation Administration. If the form is deemed proper and the relief sought appropriate, a workers' compensation judge shall execute the pauper order, and the records request will be produced without pre-payment. If the request is denied by a workers' compensation judge, all costs shall be pre-paid in full before any records are produced.

AUTHORITY NOTE: Promulgated in accordance with R.S. 23:1310.1.

HISTORICAL NOTE: Promulgated by the Louisiana Department of Labor, Office of Workers' Compensation Administration, LR 25:281 (February 1999), amended LR 25:1871 (October 1999), amended by the Louisiana Workforce Commission, Office of Workers' Compensation, LR 37:1630 (June 2011), amended by the Workforce Commission, Office of Workers' Compensation Administration, LR 42:763 (May 2016), LR 44:102 (January 2018).

### §6607. Posting of Docket

A. The clerk of the district office shall keep a docket upon which shall be entered the docket reference number of all matters set for mediation, hearing, or trial. The docket shall be posted on the Department of Labor website and in a conspicuous location of the district office on the first work day of each week for that week.

AUTHORITY NOTE: Promulgated in accordance with R.S. 23:1310.1.

HISTORICAL NOTE: Promulgated by the Department of Labor, Office of Workers' Compensation Administration, LR 25:282 (February 1999), amended LR 25:1871 (October 1999), LR 33:659 (April 2007).

## Subchapter B. Costs

### §6609. General

A. The awarding of costs shall be governed by R.S. 23:1317(B) and Code of Civil Procedure Article 1920.

B. The costs of preparing an appeal shall be initially sustained by the appellant. In the case of pauper, the costs incurred by the Office of Workers' Compensation Administration in preparing the transcript shall be sustained by the Office of Workers' Compensation Administration only where the pauper is the losing party.

AUTHORITY NOTE: Promulgated in accordance with R.S. 23:1310.1.

HISTORICAL NOTE: Promulgated by the Louisiana Department of Labor, Office of Workers' Compensation Administration, LR 25:282 (February 1999), amended LR 25:1872 (October 1999).

**§6611. Medical Costs**

A. Except as provided in R.S. 23:1034.2(E), the determination of all medical reimbursement shall be based upon the reimbursement schedule in effect at the time the services are rendered. Every attempt to resolve disputes over medical reimbursement shall be made by applying said schedule(s).

AUTHORITY NOTE: Promulgated in accordance with R.S. 23:1310.1.

HISTORICAL NOTE: Promulgated by the Department of Labor, Office of Workers' Compensation Administration, LR 25:282 (February 1999), amended LR 25:1872 (October 1999), LR 33:659 (April 2007).

**Subchapter C. Waiver of Costs for Indigent Party**

**§6613. General**

A. Waiver of costs for indigent party shall be governed by *Code of Civil Procedure*, articles 5181 et seq. The request for waiver of costs shall be made on LWC request for waiver of payment of advance costs form.

AUTHORITY NOTE: Promulgated in accordance with R.S. 23:1310.1.

HISTORICAL NOTE: Promulgated by the Department of Labor, Office of Workers' Compensation Administration, LR 25:282 (February 1999), amended LR 25:1872 (October 1999), LR 33:660 (April 2007), amended by the Workforce Commission, Office of Workers' Compensation Administration, LR 44:103 (January 2018).

**Subchapter D. Severability of Sections**

**§6627. General**

A. If any provision or item of a Section, or the application thereof, is held to be invalid, such invalidity shall not affect other provisions, items, or applications of the section which can be given effect without the invalid provision, item or application.

AUTHORITY NOTE: Promulgated in accordance with R.S. 23:1310.1.

HISTORICAL NOTE: Promulgated by the Louisiana Department of Labor, Office of Workers' Compensation Administration, LR 25:283 (February 1999), amended LR 25:1872 (October 1999).

## Subchapter E. Forms

### §6629. Annual Report of Workers' Compensation Costs; Form LDOL-WC-1000

ANNUAL REPORT OF WORKERS' COMPENSATION COSTS  
FOR CALENDAR YEAR \_\_\_\_\_

1. EMPLOYER INFORMATION		2. INSURANCE COMPANY INFORMATION	
Fed EIN: _____		Phone Number: _____ (    )	
3. Coverage Provided: <input type="checkbox"/> Self-insured / Excess Insurance <input type="checkbox"/> Conventional Workers' Compensation Policy <input type="checkbox"/> Combination of Insurance Policies [R.S. 23:1168(A)(2)]			
4. COSTS INCURRED DURING THE CALENDAR YEAR (See Instructions)			
		Paid by Employer	Paid by Insurance
A. Indemnity Benefits:			
	1. Temporary Total		
	2. Supplemental Earnings		
	3. Permanent Partial		
	4. Permanent Total		
	5. Death Benefits		
	6. Other Compensation		
	TOTAL INDEMNITY BENEFITS		
B. TOTAL COMPROMISE/LUMP SUM SETTLEMENTS:			
C. Medical Expenses:			
	1. Hospital		
	2. Physicians		
	3. Diagnostic Tests/Procedures		
	4. Prescription Drugs		
	5. Transportation		
	6. Independent Medical Exams		
	7. Physical/Occupational Therapy		
	8. Other		
	TOTAL MEDICAL EXPENSES		
D. Rehabilitation Expenses			
	1. Vocational Rehabilitation		
	2. Labor Market Surveys		
	3. Evaluations		
	4. Other		
	TOTAL REHABILITATION EXPENSES		
		Paid by Employer	Paid by Insurance

LABOR AND EMPLOYMENT

E. TOTAL FUNERAL EXPENSES			
F. Legal Expenses			
	1. Attorney Fees		
	2. Court Costs		
	3. Deposition Costs		
	4. Investigation Costs		
	5. Penalties and Interest		
	6. Administrative/Other Costs		
	TOTAL LEGAL EXPENSES		
G. Cost Summary			
	1. Total Indemnity Benefits (ITEM A)		
	2. Total Compromise/Lump Sum Settlements (ITEM B)		
	3. Total Medical Expenses (ITEM C)		
	4. Total Rehabilitation Costs (ITEM D)		
	5. Total Funeral Expenses (ITEM E)		
	6. 3rd Party Recoveries for Costs (Not Included Above)		
	7. Total Assessable Costs (1+2+3+4+5+6)		
	8. Total Legal Expenses (ITEM F)		
	<b>9. TOTAL WORKERS' COMPENSATION COSTS</b>		
H. Number of Claims Summary			
	1. Carried over from prior year		
	2. Opened during current year		
	3. Closed during current year		
	4. Open at year end ( 1 + 2 - 3)		
	5. Total Medical only claims		
I. OPEN RESERVE CLAIMS (at year end)			
	Number		
	Amount		
NOTE: The amount of compensation benefits paid will be used by the director to make assessments for the administration of the Workers' Compensation Office under the provisions of Act 29, 1983, R.S. 23:1291.1 All other information submitted will be used for statistical records only with the names of employers and carriers being confidential and privileged. (R.S. 23:1293)			
FOR OFFICIAL USE ONLY		I certify that the information contained herein is true and correct to the best of my knowledge and belief.	
		Signature	Date

AUTHORITY NOTE: Promulgated in accordance with R.S. 23:1310.1.

HISTORICAL NOTE: Promulgated by the Department of Labor, Office of Workers' Compensation Administration, LR 25:283 (February 1999).



**§6631. Notice of Payment, Modification, Suspension, Termination or Controversion of Compensation or Medical Benefits**

EMPLOYER/PAYOR MAIL TO:

OFFICE OF WORKERS' COMPENSATION

POST OFFICE BOX 94040

BATON ROUGE, LA 70804-9040

- 1. Employee Social Security No. \_\_\_\_-\_\_\_\_-\_\_\_\_
- 2. Payor Claim No.: \_\_\_\_\_
- 3. Date of Injury/Illness \_\_\_\_\_
- 4. Date of Notice: \_\_\_\_\_

**NOTICE OF PAYMENT, MODIFICATION, SUSPENSION, TERMINATION OR CONTROVERSION  
OF COMPENSATION OR MEDICAL BENEFITS**

5. Purpose of Form (check one):  
Initial Payment \_\_\_\_ Modification \_\_\_\_ Suspension \_\_\_\_ Termination \_\_\_\_ Controversion \_\_\_\_

6. (a) Employee Name: \_\_\_\_\_  
Address: \_\_\_\_\_  
Telephone: \_\_\_\_\_

(b) Employee Representative Name (if known)  
Address: \_\_\_\_\_  
Telephone: \_\_\_\_\_  
Facsimile: \_\_\_\_\_

(c) Employer Name: \_\_\_\_\_  
Address: \_\_\_\_\_  
Telephone: \_\_\_\_\_  
Facsimile: \_\_\_\_\_

7. Effective Date of Initial Payment, Modification, Suspension, Termination or Controversion: \_\_\_\_/\_\_\_\_/20\_\_\_\_

8. Description of Injury/Occupational Disease: \_\_\_\_\_

9. Average Weekly Wage: \$\_\_\_\_\_

10. Payment/Modification (check one): Initial Payment \_\_\_\_ Modification \_\_\_\_

Indemnity Benefits are to be paid as follows:

A. Permanent Total Disability (PTD)\_\_\_\_ Temporary Total Disability (TTD)\_\_\_\_ (check one) benefits at the rate of \$\_\_\_\_\_ per week;

B. Supplemental Earnings Benefits (SEB) paid at the rate of \$\_\_\_\_\_ per \_\_\_\_\_ based on a wage earning capacity of \$\_\_\_\_\_; OR

SEB paid at the rate of \$\_\_\_\_\_ per \_\_\_\_\_ dependent on wages as reflected in LWC-WC-1020's to be submitted by employee each month;

C. Reduced PTD\_\_\_\_ TTD\_\_\_\_ SEB\_\_\_\_ (check one) at the rate of \$\_\_\_\_\_ due to employee's receipt of (check applicable item):

- \_\_\_\_ Social Security Benefits at the rate of \$\_\_\_\_\_ per \_\_\_\_\_;
- \_\_\_\_ Other Workers' Compensation Benefits at the rate of \$\_\_\_\_\_ per \_\_\_\_\_;
- \_\_\_\_ Employer Funded Disability Benefits at the rate of \$\_\_\_\_\_ per \_\_\_\_\_;
- \_\_\_\_ Unemployment Insurance Benefits
- \_\_\_\_ Third Party Recovery in the amount of \$\_\_\_\_\_
- \_\_\_\_ 50% reduction of compensation based on Employee's refusal to cooperate with Vocational Rehabilitation
- \_\_\_\_ Reduction due to child support order
- \_\_\_\_ Other (Describe): \_\_\_\_\_

D. Permanent Partial Disability (PPD) Benefits of \$\_\_\_\_\_ per week payable for \_\_\_\_\_ weeks.

E. Death Benefits have begun in the amount of \$\_\_\_\_\_ per week, representing \_\_\_\_\_% of AWW.

Employee Name \_\_\_\_\_  
Date of injury/illness \_\_\_\_\_

LABOR AND EMPLOYMENT

11. Suspension/Termination

Indemnity and/or Medical Benefits have been suspended/terminated due to:

\_\_\_ Employee's refusal to submit to a medical examination;

\_\_\_ Employee's refusal to execute a Choice of Physician form;

\_\_\_ Fraud

\_\_\_ Dispute over Compensability (Describe): \_\_\_\_\_

\_\_\_ Employee's refusal to return the form LWC-WC-1025 or LWC-WC-1020;

\_\_\_ Released to return to work full duty;

\_\_\_ Employee able to earn 90% of pre-accident average weekly wage; or

\_\_\_ Other (Describe): \_\_\_\_\_

12. Controversion

Employee's rights to Indemnity and/or Medical Benefits are disputed and have been denied because Employer/Payor disputes:

\_\_\_ Compensable Work Accident;

\_\_\_ Compensable Injury;

\_\_\_ Employment Relationship;

\_\_\_ Causation;

\_\_\_ Disability;

\_\_\_ Fraud;

\_\_\_ Jurisdiction; or

\_\_\_ Other (Describe): \_\_\_\_\_

13. Notice Submitted By:

Signature of Preparer: \_\_\_\_\_

Printed name: \_\_\_\_\_

Position/Affiliation: \_\_\_\_\_

Telephone: \_\_\_\_\_

Facsimile: \_\_\_\_\_

Address: \_\_\_\_\_

14. Please provide the following information:

Payor/Self Insured Employer Name: \_\_\_\_\_

Telephone: \_\_\_\_\_

Facsimile: \_\_\_\_\_

Address: \_\_\_\_\_

Title 40, Part I

**NOTICE OF DISAGREEMENT**

(to be completed by Employee/Employee Representative)

MAIL TO: Employee Social Security No.: \_\_\_\_\_ - \_\_\_\_\_ - \_\_\_\_\_  
The preparer for Employer/Payor Payor Claim No. (if known): \_\_\_\_\_  
at the address listed in Section 13 Date of Injury/Illness: \_\_\_\_\_  
of the LWC-WC-1002. Date of Notice of Disagreement: \_\_\_\_\_

**BASIS OF DISAGREEMENT**

1. Average Weekly Wage is incorrect. The correct AWW amount is \$\_\_\_\_\_.
2. The type of workers' compensation indemnity benefits is incorrect. The correct type is PTD/TTD/SEB/PPD (circle one).
3. The amount/rate of workers' compensation indemnity benefits is incorrect. The correct amount is \$\_\_\_\_\_ per \_\_\_\_\_.
4. The basis for Employer/Payor's suspension/termination/controversion of benefits is incorrect because (describe):  
\_\_\_\_\_  
\_\_\_\_\_
5. Other (describe): \_\_\_\_\_  
\_\_\_\_\_
6. Notice Submitted By:  
Employee Name: \_\_\_\_\_  
Telephone: \_\_\_\_\_  
Address: \_\_\_\_\_  
\_\_\_\_\_  
Employee Representative \_\_\_\_\_  
La. Bar Roll No. \_\_\_\_\_  
Address: \_\_\_\_\_  
\_\_\_\_\_  
Telephone: \_\_\_\_\_  
Facsimile: \_\_\_\_\_  
Signature \_\_\_\_\_  
Printed name: \_\_\_\_\_

AUTHORITY NOTE: Promulgated in accordance with R.S. 23:1310.1.

HISTORICAL NOTE: Promulgated by the Department of Labor, Office of Workers' Compensation Administration, LR 25:286 (February 1999), amended by the Workforce Commission, Office of Workers Compensation, LR 40:387 (February 2014).

LABOR AND EMPLOYMENT

§6633. Stop Payment Form; Form LDOL-WC-1003

MAIL TO:
OFFICE OF WORKERS' COMPENSATION
POST OFFICE BOX 94040
BATON ROUGE, LA 70807-9040

SOCIAL SECURITY NUMBER

(225) 342-7565, TOLL FREE (800) 201-3457

DATE OF INJURY/ILLNESS

STOP PAYMENT FORM

This form is sent by the Employer/Insurer to the injured worker and the OWC within 30 days of the closure of a case.
An AMENDED COPY is required if the case re-opens or additional costs are incurred.

- 1. (Employee) (Date of Birth)
2. Date of this Notice
3. Part(s) of Body Injured
4. Date Compensation Paid Through

5. Purpose of Form: (check one)

- Payment stopped-Employee working at equal or greater wage
Payment stopped-Employee able to work at same or greater wage
Payment stopped-Lump sum/Compromise settlement approved
Other
Payment stopped-Maximum period for paying SEB has expired
Payment stopped-3rd Party recovery without notice
Amend or correct prior 1003

6. Length of Disability weeks days.

7. Give ICD - 9 Diagnostic code(s)

8. Give CPT Procedure code(s)

9. COSTS INCURRED FOR THIS CASE:

A. Indemnity Benefits

- 1. Temporary total \$
2. Supplemental earnings
3. Permanent partial
4. Permanent total
5. Death benefits
6. Other benefits

TOTAL INDEMNITY BENEFITS

(Add A. items 1-6)

B. TOTAL SETTLEMENT AMOUNT \$

C. Medical Expenses

- 1. Hospital \$
2. Physician
3. Diagnostic Tests/Procedures
4. Prescription Drugs
5. Transportation Costs
6. Independent Medical Exams
7. Occupational/Physical Therapy
8. Other

TOTAL MEDICAL EXPENSES

(Add C. Items 1-8)

D. Rehabilitation Expenses

- 1. Medical rehabilitation \$
2. Vocational rehabilitation
3. Labor Market Survey
4. Evaluation
5. Other

TOTAL REHABILITATION EPENSES

(Add D. Items 1-5)

E. TOTAL FUNERAL EXPENSES \$

F. Legal Expenses

- 1. Attorney Fees \$
2. Court Costs
3. Deposition Costs
4. Investigation Costs
5. Penalties and Interest
6. Administrative/Other Costs

TOTAL LEGAL EXPENSES

(Add E. Items 1-5)

G. 3RD PARTY RECOVERIES FOR COSTS \$

(NOT INCLUDED ABOVE)

H. TOTAL WORKERS' COMPENSATION COSTS \$

(Add A - G)

I. BALANCE OF UNUSED RESERVES \$

Submitted by:

Preparer's Name:

Employer/Insurer:

Address:

Phone: ( )

Employer/Insurer NCCI Number:

Phone: ( )

Employer/Insurer NCCI Number:

AUTHORITY NOTE: Promulgated in accordance with R.S. 23:1310.1.

HISTORICAL NOTE: Promulgated by the Department of Labor, Office of Workers' Compensation Administration, LR 25:287 (February 1999).

§6635. Request for Social Security Benefits Information; Form LDOL-WC-1004

REQUEST FOR SOCIAL SECURITY BENEFITS INFORMATION

(L.R.S. 23:1225)

DATE \_\_\_\_\_

NAME \_\_\_\_\_ SSN \_\_\_\_\_

Please provide information concerning the referenced worker.

Workers' Compensation Judge

Type of Social Security Benefit: \_\_\_ Disability \_\_\_ Retirement \_\_\_ Other \_\_\_ None

Current Social Security Benefit Paid to Employee ..... \$ \_\_\_\_\_

Number of Auxillaries/Dependants on Record ..... # \_\_\_\_\_

Age of Youngest Auxillary/Dependant ..... \_\_\_\_\_

PART I - CALCULATION OF INITIAL OFFSET

Date of Entitlement \_\_\_\_\_

- 1. Original 80 Percent Average Current Earnings (ACE) on Record ..... \$ \_\_\_\_\_
2. Total Family Benefit (TFB) ..... \$ \_\_\_\_\_
3. Higher of Amounts Shown Above ..... \$ \_\_\_\_\_
4. Monthly Workers' Compensation (WC) Rate
(Subject to reduction due to allowable expenses)..... \$ \_\_\_\_\_
5. Social Security Benefits Payable After Offset in Month of Entitlement
(#3 minus #4, if a negative amount show 0)..... \$ \_\_\_\_\_
6. Original Federal Offset Amount (#2 minus #5) ..... \$ \_\_\_\_\_

\*\*\*\*\*

PART II - CHANGE IN FEDERAL OFFSET AMOUNT DUE TO TRIENNIAL REDETERMINATION

OF THE ACE (42 USC 424 (F) (1) and 20 CFR 404.408(1))

Effective January \_\_\_\_\_

- 1. Redetermined 80 Percent ACE ..... \$ \_\_\_\_\_
2. Original 80 Percent ACE ..... \$ \_\_\_\_\_
3. Difference Between Original and Redetermined ACE (#2 minus #1)..... \$ \_\_\_\_\_
4. Cost of Living Allowance (COLA) Increases for Same Period of Time (Date of Entitlement Through
Date of Redetermination ..... \$ \_\_\_\_\_
5. Decrease in Offset (#3 minus #4; if negative, show 0) ..... \$ \_\_\_\_\_
6. Federal Offset Amount (#6 in Part I minus #5)..... \$ \_\_\_\_\_

The next Triennial Redetermination of the ACE should be completed in ..... / /

PREPARED BY: \_\_\_\_\_

Social Security Field Office

\*\*NOTE from the Office of the State Register: The backside of this form (LDOL-WC-1004) was not included on the disk. This form will need to be scanned or obtained from the agency.

LABOR AND EMPLOYMENT

AUTHORITY NOTE: Promulgated in accordance with R.S. 23:1310.1.

HISTORICAL NOTE: Promulgated by the Department of Labor, Office of Workers' Compensation Administration, LR 25:290 (February 1999).

§6637. Motion for Recognition of Right to Social Security Offset; Form LDOL-WC-1005A

Attached hereto and designated as "Attachment Number 5."

STATE OF LOUISIANA
DEPARTMENT OF LABOR
OFFICE OF WORKERS' COMPENSATION

\* SS#:
VERSUS \* DOCKET NO:
\* DISTRICT:

MOTION FOR RECOGNITION OF RIGHT TO SOCIAL SECURITY OFFSET

NOW INTO COURT as undersigned comes
employer/insurer in the referenced case, and requests the Workers' Compensation Judge to enter an order recognizing its right to take the reverse offset, since the claimant in this matter is receiving permanent total disability benefits under the Louisiana Workers' Compensation Act in addition to benefits under 42 U.S.C. Chapter 7, Subchapter II, entitled Federal Old Age, Survivors, and Disability Insurance Benefits.

SIGNED this the day of 20

(PRINT NAME)
Agent for

AUTHORITY NOTE: Promulgated in accordance with R.S. 23:1310.1.

HISTORICAL NOTE: Promulgated by the Louisiana Department of Labor, Office of Workers' Compensation Administration, LR 25:293 (February 1999), amended LR 25:1872 (October 1999).

§6639. Order Recognizing Right to Social Security Offset; Form LDOL-WC-1005B

Attached hereto and designated as "Attachment Number 6".

STATE OF LOUISIANA
DEPARTMENT OF LABOR OFFICE OF WORKERS' COMPENSATION

\* SS#:
VERSUS \* DOCKET NO:
\* DISTRICT:
ORDER RECOGNIZING RIGHT TO SOCIAL SECURITY OFFSET

This matter is before the Workers' Compensation Judge on the motion of the employer/insurer for recognition of its right to claim the Social Security reverse offset in this case. The Workers' Compensation Judge finds that the claimant is receiving permanent total disability benefits under the provisions of the Louisiana Workers' Compensation Act in addition to benefits under 42 U.S.C. Chapter 7, Subchapter II, entitled Federal Old Age, Survivors, and Disability Insurance Benefits. The Workers' Compensation Judge further finds the under that provisions of L.R.S. 23:1225(A) the employer/insurer has claimed and is entitled to a reduction in the Workers' Compensation benefits paid to claimant in the amount of.

IT IS THEREFORE ORDERED, ADJUDGED AND DECREED that the employer/insurer is hereby allowed to offset the Workers' Compensation benefits paid to claimant in the amount of , beginning on , 20, the date of employer/insurer's judicial demand.

IT IS FURTHER ORDERED, ADJUDGED AND DECREED that the Social Security Administration reverse its Social Security offset effective , 20, the date of employer/insurer's judicial demand.

READ, RENDERED AND SIGNED this the day of , 20 at Parish, Louisiana.

WORKERS' COMPENSATION JUDGE

AUTHORITY NOTE: Promulgated in accordance with R.S. 23:1310.1.

HISTORICAL NOTE: Promulgated by the Louisiana Department of Labor, Office of Workers' Compensation Administration, LR 25:293 (February 1999), amended LR 25:1872 (October 1999).

§6641. Subpoena for Deposition and Subpoena Duces Tecum; Form LDOL-WC-1006A

SUBPOENA FOR DEPOSITION AND SUBPOENA DUCES TECUM

\* DOCKET NO. DISTRICT
VERSUS \* OFFICE OF WORKERS' COMPENSATION
\* STATE OF LOUISIANA

TO

YOU ARE HEREBY COMMANDED to appear at the office of

address Telephone # at o'clock .m. on the day of , 20, to have your oral testimony taken in the above entitled and numbered cause.

YOU ARE/ARE NOT (circle one) FURTHER COMMANDED to produce at the above time and place the following:

This SUBPOENA was issued by the Office of Workers' Compensation on the day of , 20.

J. KAREN BEVAN, RECORDS MANAGER
Office of Workers' Compensation

This SUBPOENA was ordered by Attorney: I hereby certify I have served a copy of this subpoena on all attorneys of record.

Telephone: ( )

AUTHORITY NOTE: Promulgated in accordance with R.S. 23:1310.1.

HISTORICAL NOTE: Promulgated by the Department of Labor, Office of Workers' Compensation Administration, LR 25:294 (February 1999).

**§6643. Subpoena Deuces Tecum for Inspection; Form LDOL-WC-1006B**

**SUBPOENA AND SUBPOENA DUCES TECUM**

\_\_\_\_\_ \* **DOCKET NO.** \_\_\_\_\_ **DISTRICT**  
VERSUS \* **OFFICE OF WORKERS' COMPENSATION**  
\_\_\_\_\_ \* **STATE OF LOUISIANA**  
**TO** \_\_\_\_\_

**YOU ARE HEREBY COMMANDED** to appear before the Workers' Compensation Court at

\_\_\_\_\_,  
Telephone # \_\_\_\_\_ at \_\_\_\_\_ o'clock

\_\_\_\_\_.m. on the \_\_\_\_\_ day of \_\_\_\_\_, 20\_\_\_\_, or on any other day that this matter may be continued to give testimony in the above entitled and numbered cause. **You must remain in Court until discharged by the Judge. You must testify to the truth, to the best of your knowledge in this case.**

**YOU ARE/ARE NOT (circle one) FURTHER COMMANDED** to produce at the above time and place the following:

FAILURE TO APPEAR OR PRODUCE AS DIRECTED ABOVE SHALL SUBJECT YOU TO ANY PENALTY AS PRESCRIBED BY LAW.

This **SUBPOENA** was issued by the Office of Workers' Compensation on the \_\_\_\_\_ day of \_\_\_\_\_, 20\_\_\_\_.

**J. KAREN BEVAN, RECORDS MANAGER**  
**Office of Workers' Compensation**

This **SUBPOENA** was ordered by Attorney: \_\_\_\_\_ I hereby certify I have served a copy of this subpoena on all attorneys of record.  
\_\_\_\_\_  
\_\_\_\_\_

Telephone: (\_\_\_\_) \_\_\_\_\_

**AUTHORITY NOTE:** Promulgated in accordance with R.S. 23:1310.1.

**HISTORICAL NOTE:** Promulgated by the Department of Labor, Office of Workers' Compensation Administration, LR 25:294 (February 1999).

**§6645. Subpoena and Subpoena Deuces Tecum; Form LDOL-WC-1006C**

**SUBPOENA AND SUBPOENA DUCES TECUM**

\_\_\_\_\_ \* **DOCKET NO.** \_\_\_\_\_ **DISTRICT**  
VERSUS \* **OFFICE OF WORKERS' COMPENSATION**  
\_\_\_\_\_ \* **STATE OF LOUISIANA**  
**TO** \_\_\_\_\_

**YOU ARE HEREBY COMMANDED** to appear before the Workers' Compensation Court at

\_\_\_\_\_,  
Telephone # \_\_\_\_\_ at \_\_\_\_\_ o'clock

\_\_\_\_\_.m. on the \_\_\_\_\_ day of \_\_\_\_\_, 20\_\_\_\_, or on any other day that this matter may be continued to give testimony in the above entitled and numbered cause. **You must remain in Court until discharged by the Judge. You must testify to the truth, to the best of your knowledge in this case.**

**YOU ARE/ARE NOT (circle one) FURTHER COMMANDED** to produce at the above time and place the following:

FAILURE TO APPEAR OR PRODUCE AS DIRECTED ABOVE SHALL SUBJECT YOU TO ANY PENALTY AS PRESCRIBED BY LAW.

This **SUBPOENA** was issued by the Office of Workers' Compensation on the \_\_\_\_\_ day of \_\_\_\_\_, 20\_\_\_\_.

**J. KAREN BEVAN, RECORDS MANAGER**  
**Office of Workers' Compensation**

This **SUBPOENA** was ordered by Attorney: \_\_\_\_\_ I hereby certify I have served a copy of this subpoena on all attorneys of record.  
\_\_\_\_\_  
\_\_\_\_\_

Telephone: (\_\_\_\_) \_\_\_\_\_

**AUTHORITY NOTE:** Promulgated in accordance with R.S. 23:1310.1.

**HISTORICAL NOTE:** Promulgated by the Department of Labor, Office of Workers' Compensation Administration, LR 25:294 (February 1999).

LABOR AND EMPLOYMENT

§6647. Employer's Report of Injury/Illness; Form LWC-WC-IA-1

Workers Compensation—First Report of Injury or Illness

EMPLOYER (NAME & ADDRESS INCL ZIP)		CARRIER/ADMINISTRATOR CLAIM NUMBER	OSHA LOG NUMBER	REPORT PURPOSE CODE
		JURISDICTION	JURISDICTION CLAIM NUMBER	
		INSURED REPORT NUMBER		
		EMPLOYER'S LOCATION ADDRESS (IF DIFFERENT)		LOCATION #
INDUSTRY CODE	EMPLOYER FEIN			PHONE #
<b>CARRIER/CLAIMS ADMINISTRATOR</b>				
CARRIER (NAME, ADDRESS, & PHONE #)		POLICY PERIOD	CLAIMS ADMINISTRATOR (NAME, ADDRESS & PHONE NO)	
		TO		
		CHECK IF APPROPRIATE		
		SELF INSURANCE		
CARRIER FEIN	POLICY/SELF-INSURED NUMBER	ADMINISTRATOR FEIN		
AGENT NAME & CODE NUMBER				
<b>EMPLOYEE/WAGE</b>				
NAME (LAST, FIRST, MIDDLE)		DATE OF BIRTH	SOCIAL SECURITY NUMBER	DATE HIRED
				STATE OF HIRE
ADDRESS (INCL ZIP)		SEX	MARITAL STATUS	OCCUPATION/JOB TITLE
		M MALE	J UNMARRIED SINGLE/DIVORCED	EMPLOYMENT STATUS
		F FEMALE UNKNOWN	M MARRIED	
			S SEPARATED	
			K UNKNOWN	NCCI CLASS CODE
PHONE	# OF DEPENDENTS			
RATE PER:	DAY WEEK	MONTH OTHER:	DAYS WORKED/WEEK	FULL PAY FOR DAY OF INJURY? DID SALARY CONTINUE?
				YES NO YES NO
<b>OCCURRENCE/TREATMENT</b>				
TIME EMPLOYEE BEGAN WORK	AM PM	DATE OF INJURY/ILLNESS	TIME OF OCCURRENCE ( ) CANNOT BE DETERMINED	AM PM
				LAST WORK DATE
				DATE EMPLOYER NOTIFIED
				DATE DISABILITY BEGAN
CONTACT NAME/PHONE NUMBER		TYPE OF INJURY/ILLNESS		PART OF BODY AFFECTED
DID INJURY/ILLNESS/EXPOSURE OCCUR ON EMPLOYER'S PREMISES?		TYPE OF INJURY/ILLNESS CODE		PART OF BODY AFFECTED CODE
<input type="checkbox"/> YES <input type="checkbox"/> NO				
DEPARTMENT OR LOCATION WHERE ACCIDENT OR ILLNESS EXPOSURE OCCURRED		ALL EQUIPMENT, MATERIALS, OR CHEMICALS EMPLOYEE WAS USING WHEN ACCIDENT OR ILLNESS EXPOSURE OCCURRED		
SPECIFIC ACTIVITY THE EMPLOYEE WAS ENGAGED IN WHEN THE ACCIDENT OR ILLNESS EXPOSURE OCCURRED		WORK PROCESS THE EMPLOYEE WAS ENGAGED IN WHEN ACCIDENT OR ILLNESS EXPOSURE OCCURRED		
HOW INJURY OR ILLNESS/ABNORMAL HEALTH CONDITION OCCURRED. DESCRIBE THE SEQUENCE OF EVENTS AND INCLUDE ANY OBJECTS OR SUBSTANCES THAT DIRECTLY INJURED THE EMPLOYEE OR MADE THE EMPLOYEE ILL				
				CAUSE OF INJURY CODE
DATE RETURN(ED) TO WORK	IF FATAL, GIVE DATE OF DEATH	WERE SAFEGUARDS OR SAFETY EQUIPMENT PROVIDED?		YES NO
		WERE THEY USED?		YES NO
PHYSICIAN/HEALTH CARE PROVIDER (NAME & ADDRESS)		HOSPITAL OR OFF SITE TREATMENT (NAME & ADDRESS)		INITIAL TREATMENT
				0 NO MEDICAL TREATMENT
				1 MINOR: BY EMPLOYER
				2 MINOR CLINIC/HOSP
				3 EMERGENCY CARE
				4 HOSPITALIZED > 24 HOURS
				5 FUTURE MAJOR MEDICAL/ LOST TIME ANTICIPATED
<b>OTHER</b>				
WITNESSES (NAME & PHONE #)				
DATE ADMINISTRATOR NOTIFIED	DATE PREPARED	PREPARER'S NAME & TITLE		PHONE NUMBER



Title 40, Part I

AUTHORITY NOTE: Promulgated in accordance with R.S. 23:1310.1.

HISTORICAL NOTE: Promulgated by the Louisiana Workforce Commission, Office of Workers Compensation, LR 38:3252 (December 2012).

§6649. Disputed Claim for Compensation; Form LDOL-WC-1008

Mail To: LOCAL DISTRICT OFFICE OR OFFICE OF WORKERS' COMPENSATION POST OFFICE BOX 94040 BATON ROUGE, LA 70804-9040 For information call (225) 342-7565 or Toll Free (800) 201-3457

- 1. Social Security No. 2. Date of Injury/Illness 3. Part(s) of Body Injured 4. Date of This Request 5. Date of Hire 6. Date of Birth

Docket Number

DISPUTED CLAIM FOR COMPENSATION

- 7. This claim is submitted by: Employee Employer Insurer Dependent Health Care Provider LDOL Other

GENERAL INFORMATION

Claimant files this dispute with the Office of Workers' Compensation. This Office must be notified immediately in writing of changes in address. An employee may be represented by an attorney, but it is not required.

EMPLOYEE

EMPLOYEE'S ATTORNEY

8. Name Street or Box City State Zip Phone

9. Name Street or Box City State Zip Phone

EMPLOYER

INSURER/ADMINISTRATOR (circle one)

10. Name Attn: Street or Box City State Zip Phone

11. Name Attn: Street or Box City State Zip Phone

EMPLOYER/INSURER'S ATTORNEY (circle one)

DEPENDENT/HCP/OTHER (circle one)

12. Name Attn: Street or Box City State Zip Phone

13. Name Relationship Street or Box City State Zip Phone

14. EMPLOYMENT DATA

Occupation: Average Weekly Wage \$ Workers' Compensation Rate \$

LABOR AND EMPLOYMENT

15. TO BE COMPLETED BY INJURED EMPLOYEE OR DEPENDENT:

(A) ACCIDENT DATA

Date, time and place of accident: \_\_\_\_\_

Parish of Residence at time of Injury/Illness \_\_\_\_\_

Accident reported on \_\_\_\_ / \_\_\_\_ / \_\_\_\_, to \_\_\_\_\_ whose position with the employer is \_\_\_\_\_

Describe the accident and injury in detail (person/equipment involved, type of injury, etc.) \_\_\_\_\_

List the names, addresses, telephone numbers of any witnesses.

(B) MEDICAL DATA

State the names, addresses, and telephone numbers of hospitals, clinics and doctors who have provided medical attention.

(C) THE BONA-FIDE DISPUTE

Check the following that apply and fill in the blanks:

- 1. No wage benefits have been paid
2. No medical treatment has been authorized
3. Occupational Disease
4. Workers' Compensation Rate is Incorrect - Should be \$
5. Wage benefits terminated or reduced on
6. Medical treatment (Procedure/Prescription) recommended by not authorized.
7. Choice of physician (specialty)
8. Disability status
9. Vocational Rehabilitation - specify
10. Offset/Credit
11. Refusal to authorize/submit to evaluation with choice of physician/Independent Medical Examination [R.S. 23:1121, 1124.B, or 1317.1.F]
12. Other:

NOTE: You may attach a letter or petition with additional information with this disputed claim or when later amending this disputed claim (Form LDOL-WC-1008). You must provide a copy of this claim and any amendment to all opposing parties.

The information given above is true and correct to the best of my knowledge and belief.

SIGNATURE OF CLAIMANT/ATTORNEY (circle one)

DATE

AUTHORITY NOTE: Promulgated in accordance with R.S. 23:1310.1.

HISTORICAL NOTE: Promulgated by the Department of Labor, Office of Workers' Compensation Administration, LR 25:297 (February 1999).

§6651. Request for Compromise and Lump Sum Settlement; Form LDOL-WC-1011

RETURN TO: OFFICE OF WORKERS' COMPENSATION POST OFFICE BOX 94040 BATON ROUGE, LA 70804-9040 (225) 342-7565 TOLL FREE (800) 201-3457

- 1. Social Security No.
2. Date of Injury/Illness
3. Part(s) of Body Injured
4. OWC Docket Number
5. OWC District Number

REQUEST FOR COMPROMISE OR LUMP SUM SETTLEMENT

DATE OF APPROVAL

Title 40, Part I

JUDGE

EMPLOYEE

6. Name \_\_\_\_\_
Street or Box \_\_\_\_\_
City \_\_\_\_\_
State \_\_\_\_\_ Zip \_\_\_\_\_
Phone ( ) \_\_\_\_\_

EMPLOYER

8. Name \_\_\_\_\_
Street or Box \_\_\_\_\_
City \_\_\_\_\_
State \_\_\_\_\_ Zip \_\_\_\_\_
Phone ( ) \_\_\_\_\_

EMPLOYER/INSURER'S ATTORNEY

(circle one)

10. Name \_\_\_\_\_
Street or Box \_\_\_\_\_
City \_\_\_\_\_
State \_\_\_\_\_ Zip \_\_\_\_\_
Phone ( ) \_\_\_\_\_

11. DATE OF SETTLEMENT CONFERENCE \_\_\_\_\_

12. TERMS AND AMOUNT OF SETTLEMENT: \_\_\_\_\_

13. BENEFITS PAID TO DATE:

- a.) AVERAGE WEEKLY WAGE: \_\_\_\_\_
b.) WORKERS' COMPENSATION BENEFITS: \_\_\_\_\_
c.) MEDICAL BENEFITS: \_\_\_\_\_
d.) DEATH BENEFITS: \_\_\_\_\_

14. ATTORNEY FEES PAID TO DATE: \_\_\_\_\_

15. ADDITIONAL FEES REQUIRED: \_\_\_\_\_

ATTACHMENTS REQUIRED:

- JOINT PETITION MOST RECENT MEDICAL REPORT
FORM 1007 ATTACHED OR ON FILE WAIVER OF RIGHTS UNDER L.R.S. 23:1271
FORM 1003 ATTACHED OR ON FILE FILING FEE PAID
EMPLOYEE AFFIDAVIT ORDER OF APPROVAL
EMPLOYER CONCURRENCE MOTION AND ORDER FOR ATTORNEY FEES
ALLEGATION OF LEGAL REPRESENTATION MOTION AND ORDER TO DISMISS 1008
(IF APPLICABLE)

SUBMITTED BY: \_\_\_\_\_

PHONE: ( ) \_\_\_\_\_

NOTE: \*Note from the Office of the State Register: The backside of Form LDOL-WC-1011, Request for Compromise or Lump Sum Settlement, was not included on the disk. This form will need to be scanned or obtained from the agency.

AUTHORITY NOTE: Promulgated in accordance with R.S. 23:1310.1.

HISTORICAL NOTE: Promulgated by the Department of Labor, Office of Workers' Compensation Administration, LR 25:299 (February 1999).

LABOR AND EMPLOYMENT

§6653. Request for Independent Medical Examination; Form LDOL-WC-1015

RETURN TO:
OFFICE OF WORKERS' COMPENSATION
POST OFFICE BOX 94040
BATON ROUGE, LA 70804-9040
(225) 342-7559
TOLL FREE (800) 201-2494

- 1. Social Security No.
2. Date of Injury/Illness
3. Part(s) of Body Injured
4. Date of Birth
5. OWC Docket Number
6. OWC District Number

REQUEST FOR INDEPENDENT MEDICAL EXAMINATION

NOTE: THIS REQUEST WILL NOT BE HONORED UNLESS A DISPUTE HAS ARISEN AS TO CONDITION OF THE EMPLOYEE AS PER L. R. S. 23:1123

7. This form is submitted by:
Employee Employer Insurer TPA/Self Insurance Fund

- A. The choice of the medical practitioner shall be that of the Director of the Office of Workers' Compensation as per L. R. S. 23:1123.
B. A cover letter outlining the conflicting medical issue(s) in dispute (reason for request) along with the conflicting medical reports must be attached to this form.
C. A list of names, addresses, phone numbers and reports of all physicians/medical providers who have treated or examined the injured employee for this injury must be included. Indicate who chose each health care provider.
D. A copy of this request must be mailed to all parties.

EMPLOYEE

EMPLOYEE'S ATTORNEY

8. Name
Street or Box
City
State Zip
Phone ( )

9. Name
Street or Box
City
State Zip
Phone ( )

EMPLOYER

INSURER / ADMINISTRATOR (circle one)

10. Name
Street or Box
City
State Zip
Phone ( )

11. Name
Street or Box
City
State Zip
Phone ( )

EMPLOYER / INSURER'S ATTORNEY (circle one)

12. Name
Street or Box
City
State Zip
Phone ( )

Signature of Applicant

Date

AUTHORITY NOTE: Promulgated in accordance with R.S. 23:1310.1.

HISTORICAL NOTE: Promulgated by the Department of Labor, Office of Workers' Compensation Administration, LR 25:301 (February 1999).

**§6655. Employer's Report of Occupational Injury and Illness Quarterly Summary; Form LDOL-WC-1017A**

<b>EMPLOYEE'S QUARTERLY REPORT OF EARNINGS</b>	
<p>You must submit this Report to your workers' compensation insurer within 14 days. Your workers' compensation benefits may be suspended if you do not timely submit this Report. You would be entitled to all suspended benefits after this report is provided to your Insurer, if you are otherwise eligible for benefits.</p> <p>You do not have to file this report if you have timely filed all necessary LDOL-WC-1020 Forms, or if you have only received medical benefits.</p>	
<p><b>DO NOT</b> leave any blanks on this Report. Print or type all responses, and use N/A (not applicable) or -0- (zero) where appropriate.</p>	
1.	The information in this Report is true for the period beginning _____, 20 ____ and ending _____, 20 ____.
2.	The name and address of the employer that I am receiving benefits from is: _____
3.	Did you work for this employer in the past quarter? _____ If yes, how much were your gross wages? \$ _____
4.	Did you work for any other employer in the past quarter? _____ If yes, the name and address of the employer is _____ _____ If yes, how much were your gross wages? \$ _____
5.	Did you have any earnings through self employment in the past quarter? _____ If yes, how much? \$ _____
6.	Did you receive any unemployment compensation benefits in the past quarter? _____ If yes, how much? \$ _____
7.	I received \$ _____ in old age benefits under Title II of the Social Security Act.
8.	I received \$ _____ in Social Security Disability Benefits or other disability benefits.

AUTHORITY NOTE: Promulgated in accordance with R.S. 23:1310.1.

HISTORICAL NOTE: Promulgated by the Department of Labor, Office of Workers' Compensation Administration, LR 25:302 (February 1999).

**§6657. Employee's Monthly Report of Earnings; Form LDOL-WC-1020**

<b>EMPLOYEE CERTIFICATION</b>			
<p>I certify that I can read the English language, that I have this entire document and understand its contents, and that I understand I am held responsible for this information. I certify my answers are complete and true, and certify my compliance with the Louisiana Workers' Compensation Act.</p>			
_____	_____	_____	
PRINT NAME	SIGNATURE	SOCIAL SECURITY NUMBER	
_____	_____	( ) _____	_____
ADDRESS	CITY	STATE / ZIP	PHONE NUMBER
_____	_____	_____	_____
EMPLOYER NAME			DATE

AUTHORITY NOTE: Promulgated in accordance with R.S. 23:1310.1.

HISTORICAL NOTE: Promulgated by the Department of Labor, Office of Workers' Compensation Administration, LR 25:304 (February 1999).

LABOR AND EMPLOYMENT

**§6659. Employee and Employer Certificate of Compliance; Form LDOL-WC-1025**

<b>EMPLOYEE</b>														
<b>CERTIFICATE OF COMPLIANCE</b>														
<p><b>You must submit this form to your employer's workers' compensation insurer or to your employer within 14 days of its receipt.</b> Your workers' compensation benefits may be suspended if you do not timely submit this Certification. You would be entitled to all suspended benefits after this Certification is provided to your insurer, if you are otherwise eligible for benefits.</p> <p>It is unlawful for you to work and receive workers' compensation indemnity disability, except for supplemental earnings benefits. Supplemental earnings benefits are paid when an employee is able to work, but is unable to earn 90 percent or more of his pre-injury wages as a result of a job related accident. As an injured worker, you must notify your employer or insurer of the earning of any wages, changes in employment or medical status, receipt of unemployment benefits, receipt of Social Security benefits and receipt of retirement benefits. If you receive benefits for more than 30 days, you will be required to certify your earnings to your insurer quarterly.</p> <p>It is unlawful for you to receive workers' compensation indemnity disability benefits and unemployment benefits at the same time, except for permanent partial disability benefits. Permanent partial disability benefits are paid solely for amputation or for anatomical loss of use of a body part or function. If you violate this provision, you may be fined up to \$10,000, imprisoned up to 90 days, or both.</p> <p>It is unlawful for you to willfully make, or to assist or counsel someone else to make, a false statement or representation in order to obtain or to defeat workers' compensation benefits. If you violate this provision, you may be fined, imprisoned, or both, as follows:</p> <table border="1" style="width: 100%; border-collapse: collapse;"> <thead> <tr> <th style="text-align: left;"><u>Unlawful Benefits</u></th> <th style="text-align: left;"><u>Fine</u></th> <th style="text-align: left;"><u>Imprisonment</u></th> </tr> </thead> <tbody> <tr> <td>\$10,000 or more</td> <td>up to \$10,000</td> <td>up to 10 years, with or without hard labor</td> </tr> <tr> <td>\$2,500 or more but less than \$10,000</td> <td>up to \$ 5,000</td> <td>up to 5 years, with or without hard labor</td> </tr> <tr> <td>less than \$2,500</td> <td>up to \$500</td> <td>up to 6 months</td> </tr> </tbody> </table> <p>In addition to these criminal penalties, you may be assessed a civil penalty of up to \$5,000 and may forfeit your right to receive workers' compensation benefits.</p>			<u>Unlawful Benefits</u>	<u>Fine</u>	<u>Imprisonment</u>	\$10,000 or more	up to \$10,000	up to 10 years, with or without hard labor	\$2,500 or more but less than \$10,000	up to \$ 5,000	up to 5 years, with or without hard labor	less than \$2,500	up to \$500	up to 6 months
<u>Unlawful Benefits</u>	<u>Fine</u>	<u>Imprisonment</u>												
\$10,000 or more	up to \$10,000	up to 10 years, with or without hard labor												
\$2,500 or more but less than \$10,000	up to \$ 5,000	up to 5 years, with or without hard labor												
less than \$2,500	up to \$500	up to 6 months												

<b><u>EMPLOYEE CERTIFICATION</u></b>			
<p>I certify that I can read the English language, that I have read this entire document and understand its contents, and that I understand I am held responsible for this information. I certify my compliance with the Louisiana Workers' Compensation Act.</p>			
Print Name	Signature	Social Security Number	Date
Address	City	State / Zip	(    ) Phone Number

AUTHORITY NOTE: Promulgated in accordance with R.S. 23:1310.1.

HISTORICAL NOTE: Promulgated by the Department of Labor, Office of Workers' Compensation Administration, LR 25:305 (February 1999).

**§6661. Employee's Quarterly Report of Earnings;  
Form LDOL-WC-1026**

<b>EMPLOYEE'S QUARTERLY REPORT OF EARNINGS</b>	
<p>You must submit this Report to your workers' compensation insurer within 14 days. Your workers' compensation benefits may be suspended if you do not timely submit this Report. You would be entitled to all suspended benefits after this report is provided to your Insurer, if you are otherwise eligible for benefits.</p> <p>You do not have to file this report if you have timely filed all necessary LDOL-WC-1020 Forms, or if you have only received medical benefits.</p>	
<p><b>DO NOT</b> leave any blanks on this Report. Print or type all responses, and use N/A (not applicable) or -0- (zero) where appropriate.</p>	
1.	The information in this Report is true for the period beginning _____, 19 ____ and ending _____, 19 ____
2.	The name and address of the employer that I am receiving benefits from is: _____ _____
3.	Did you work for this employer in the past quarter? _____ If yes, how much were your gross wages? \$ _____
4.	Did you work for any other employer in the past quarter? _____ If yes, the name and address of the employer is _____ _____ If yes, how much were your gross wages? \$ _____
5.	Did you have any earnings through self employment in the past quarter? _____ If yes, how much? \$ _____
6.	Did you receive any unemployment compensation benefits in the past quarter? _____ If yes, how much? \$ _____
7.	I received \$ _____ in old age benefits under Title II of the Social Security Act.
8.	I received \$ _____ in Social Security Disability Benefits or other disability benefits.

<b>EMPLOYEE CERTIFICATION</b>			
<p>I certify that I can read the English language, that I have this entire document and understand its contents, and that I understand I am held responsible for this information. I certify my answers are complete and true, and certify my compliance with the Louisiana Workers' Compensation Act.</p>			
_____ PRINT NAME	_____ SIGNATURE	_____ SOCIAL SECURITY NUMBER	
_____ ADDRESS	_____ CITY	_____ STATE / ZIP	(____) _____ PHONE NUMBER
_____ EMPLOYER NAME		_____ DATE	

AUTHORITY NOTE: Promulgated in accordance with R.S. 23:1310.1.

HISTORICAL NOTE: Promulgated by the Department of Labor, Office of Workers' Compensation Administration, LR 25:307 (February 1999).

**§6662. Attorney Fee Notice of Lien;  
Form LDOL-WC-1027**

Attached hereto and designated as "Attachment Number 16."

DOCKET NO.: \_\_\_\_\_

CLAIMANT: \_\_\_\_\_

REPRESENTATIVES: \_\_\_\_\_

EMPLOYER: \_\_\_\_\_

**NOTICE OF LIEN**

Pursuant to Section 5547(B) of the hearing rules of the Office of Workers' Compensation Administration, \_\_\_\_\_ serves notice upon this Honorable Court and all parties to the above entitled claim that (he/she/it) represented the claimant from (date) to (date) and hereby asserts a lien on the proceeds of the claim for unpaid attorney fees.

Respectfully submitted,

\_\_\_\_\_

LABOR AND EMPLOYMENT

AUTHORITY NOTE: Promulgated in accordance with R.S. 23:1310.1.

HISTORICAL NOTE: Promulgated by the Louisiana Department of Labor, Office of Workers' Compensation Administration, LR 25:1873 (October 1999).

§6663. Scheduling Order; Form LDOL-WC-1028

Attached hereto and designated as "Attachment Number 17."

CLAIMANT DOCKET NUMBER:
OFFICE OF WORKERS' COMPENSATION
VERSUS
DISTRICT \_\_ - \_\_\_\_\_
EMPLOYER STATE OF LOUISIANA

SCHEDULING ORDER

On \_\_\_\_\_, a scheduling conference was held pursuant to Section 6001 of the hearing rules of the Office of Workers' Compensation Administration.

PRESENT:

\_\_\_\_\_ representing \_\_\_\_\_
\_\_\_\_\_ representing \_\_\_\_\_
\_\_\_\_\_ representing \_\_\_\_\_

IT IS ORDERED:

- 1. Amendment to pleadings:
2. Discovery anticipated by the parties:
3. All amendments to pleadings are to be filed by \_\_\_\_\_
4. The cut-off date for discovery is \_\_\_\_\_
5. All pre-trial motions are to be filed by \_\_\_\_\_
6. The pre-trial conference is scheduled on \_\_\_\_\_ at \_\_\_\_\_ M
7. The pre-trial mediation will be held on \_\_\_\_\_
8. Trial is scheduled for \_\_\_\_\_

IT IS FURTHER ORDERED that a pre-trial statement shall be filed ten days prior to the pre-trial conference. The attorneys who will try the case shall participate in the pre-trial conference unless prior to the conference the Judge grants permission for other representatives to attend. Whoever participates in the conference must be familiar with the case and have authority to discuss the possibilities of settlement and stipulations. \_\_\_\_\_, LOUISIANA, THIS \_\_\_\_ DAY OF \_\_\_\_\_, 20\_\_

Judge
Office of Workers' Compensation
District \_\_\_\_\_

AUTHORITY NOTE: Promulgated in accordance with R.S. 23:1310.1.

HISTORICAL NOTE: Promulgated by the Louisiana Department of Labor, Office of Workers' Compensation Administration, LR 25:1873 (October 1999).

§6664. Choice of Physician; Form LDOL-WC-1121

Notice to Injured Workers

You have the right to choose your own doctor!

When you are injured at work or become sick because of something that happened at work, the law gives you the right to choose your own doctor in any field or specialty of medicine for medical treatment.

The law also allows your employer to have you see his/her doctor, but you do not have to agree to continue treatment with your employer's doctor unless that is what you want.

If you want your employer's doctor to continue treating you after your first visit with him/her, and after receiving this form, you may choose your employer's doctor as your treating doctor.

Once you choose either your employer's doctor or your own doctor as your treating doctor, you may not be permitted to choose another doctor in that same field or specialty to treat you for your injury or illness later on. However, you are not required to get your employer's approval to change to a doctor in another field or specialty of medicine [R.S. 23:1121(b)(1)].

If your employer denies your right to choose your doctor, you have a right to a speedy hearing before a workers' compensation judge to resolve the denial of your right [R.S. 23:1121(b)(1)and 1124(b)].

I hereby choose my own doctor to treat me for my injury or illness:

Dr. \_\_\_\_\_

or

By signing this form, I state that I know about my right to choose my own treating doctor, and being so advised, I hereby accept and choose to continue treating with my employer's doctor:



Dr. \_\_\_\_\_  
 \_\_\_\_\_  
 Date Signature of Employee Printed Name of Employee

\_\_\_\_\_  
 Date Signature of Employee Printed Name of Employee

(Note: If the employee is illiterate or has a language barrier, an authorized representative of the employer/insurer shall attest by their signature that this form and right of physician choice has been reasonably explained to that employee prior to his/her signature on this form. Failure to do so can jeopardize the employer's/insurer's right to subsequently refuse consent to the employee's request for treatment by a different physician within the same field or specialty.)

**AUTHORITY NOTE:** Promulgated in accordance with R.S. 23:1310.1.

**HISTORICAL NOTE:** Promulgated by the Department of Labor, Office of Workers' Compensation Administration, LR 30:2067 (September 2004).

**§6665. Workers' Compensation Records Request Form; LWC-WC-1150**

**WORKERS' COMPENSATION RECORDS REQUEST FORM**

**Mail completed form to:**  
 Louisiana Workforce Commission  
 OWCA Records Management Section  
 1001 A, 23<sup>rd</sup> Street  
 P.O. Box 9000  
 Baton Rouge, LA 70804-9000  
 Telephone No. 225-343-7343

**Status of your records request: (Who you are only.)**  
 Will be processed.  
 Is being reviewed. See Section III, Page 2.  
 Has been processed. You owe a copying fee. See Section III, Page 2.  
 Is complete. See Section III, Page 2.

**Note:** Copies of documents provided through this request shall adhere to the provisions of La. R.S. 22:1203.1, et seq. and La. R.S. 40:1, et seq., which limits the inspection and copying of workers' compensation records. \*A \$25.00 fee is required per employee search. (Exception: Requests for LWC-WC status will not be assessed a \$25.00 search fee.) Copying fees are \$0.25 per page. There are no charges payable to the OWCA Administrative Fund.

**SECTION II: TO BE COMPLETED BY REQUESTOR**

1. Select all that apply:  
 I am the Employee  Legal Representative of the Employee. (Attach letter of representation.)  
 I am the Employer/Insurer  Legal Representative of the Employer/Insurer. (Attach letter of representation.)  
 I am not a party to a workers' compensation claim. (Attach employee authorization, LWC-WC-1181.) (Must be notarized.)  
 I am a Prospective Employee. (Attach employee authorization, LWC-WC-1182.) (Must be notarized.)

2. Name of Requestor (Please Print) \_\_\_\_\_ 3. Phone Number \_\_\_\_\_  
 4. Company Name (if applicable) \_\_\_\_\_ 5. Fax Number \_\_\_\_\_  
 6. Address, City, State ZIP \_\_\_\_\_ 7. Email \_\_\_\_\_

**SECTION III: RECORDS REQUESTED**

1. Employee's Name (Please use it separate form for each employee.) \_\_\_\_\_ 2. Employee's Social Security Number \_\_\_\_\_

3. Identify the workers' compensation claim you are requesting:  
 Workers' Compensation Claim (Check # \_\_\_\_\_ Date of Injury \_\_\_\_\_)  
 All claims for this injured worker.  
 \*If known, list the check # and date of injury for each claim in the **Additional Comments** section. You will be assessed a \$25.00 search fee for each workers' compensation check number.

4. Additional records I am requesting:  
 Notice of Payment, Modification, Suspension, Termination or Continuation of Compensation or Medical Benefits (LWC-WC-1202).  
 \*Only available to Employee or Employee Representative per La. R.S. 22:1203.1. You will not be assessed a \$25.00 search fee for this records request.  
 Other documents requested. Please specify in the **Additional Comments** section.

5. Need records certified? (If certified, you will be assessed \$25.00)  
 Yes  No

LWC-WC-1150 Page 1 of 2 Revised 03/2024

I have read and understand this form and the accompanying instructions. I certify that all information provided by me to the Office of Workers' Compensation Administration is accurate and correct to the best of my knowledge. I understand that providing false or misleading information may subject me to prosecution.

Signature of Requestor \_\_\_\_\_ Date \_\_\_\_\_

**SECTION III: TO BE COMPLETED BY OWCA RECORDS MANAGEMENT SECTION**

1. This records request will NOT be processed due to the following:  
 \$25.00 search fee not received.  
 No Social Security Number/incomplete number.  
 Employee Authorization form required.  
 Incomplete information. Please provide: \_\_\_\_\_  
 \*Your request will not be processed until the information is provided.

2. Your request has been processed.  
 \_\_\_\_\_ Pages of responsive records have been found. Please submit a check in the amount of \$ \_\_\_\_\_ to the OWCA Administrative Fund. \*No records will be sent until the check is received by the OWCA.  
 Your request has produced more than one employee claim. \_\_\_\_\_ claims have been found. Please submit a check in the amount of \$ \_\_\_\_\_ to the OWCA Administrative Fund. \*No records will be sent until the check is received by the OWCA.

3. Your request is complete. The records search has:  No Records Found  See Attached records.

Records request completed by \_\_\_\_\_ Date: \_\_\_\_\_

LWC-WC-1150 Page 2 of 2 Revised 03/2024

**AUTHORITY NOTE:** Promulgated in accordance with R.S. 23:1310.1 and R.S. 23:1293.

**HISTORICAL NOTE:** Promulgated by the Workforce Commission, Office of Workers' Compensation Administration, LR 44:103 (January 2018), repromulgated LR 44:798 (April 2018), amended LR 50:832 (June 2024).

§6667. Employee Authorization for OWCA to Release

**EMPLOYEE AUTHORIZATION FOR OWCA TO RELEASE  
CONFIDENTIAL WORKERS' COMPENSATION RECORDS**

**EMPLOYEE:** Please be aware that you **DO NOT** have to release all of your confidential information and you have a right to refuse to sign this document. You can choose to release only your public records, which includes: any final decision, award, or order of a workers' compensation judge. However, if you choose to release all of your confidential workers' compensation information, you **MUST** authorize the Office of Workers' Compensation Administration to release your confidential records information to anyone not a party to your workers' compensation claim. \*This release must be attached to the Employee Workers' Compensation Records Request Form.

**SECTION I: TO BE COMPLETED BY EMPLOYEE**

1. Employee's Full Name (Please Print)	2. Social Security Number
3. Street Address	4. Date of Birth
5. City, State, Zip	6. Phone Number

7. What records do you want to release?

Only my workers' compensation claim(s) information that is considered public record under La. R.S. 23:1293(8)(1) which only includes: final decision(s), award(s), or order(s) of a workers' compensation judge.

**OR**

Any and all of my workers' compensation claim(s) information, including confidential information, medical records, wage information, etc. in the possession of the Office of Workers' Compensation Administration, Records Management.

I understand that the Louisiana Workers' Compensation Act, La. R.S. 23:1020.1, et seq., provides that certain information regarding prior work related injuries may be released to a requesting party. By signing this authorization, I hereby voluntarily authorize the State of Louisiana, Office of Workers' Compensation Administration, Records Management Section to release only the information selected above in Section I and contained in my workers' compensation records, if any, to the Recipient named in Section II. This release may contain public and non-public records in my workers' compensation file(s) depending on my selection in Section I. This release is only for the recipient named in Section II and shall not be released to any third parties or any party not specifically named on this authorization.

This authorization will expire thirty (30) days from the date of signature.

Employee's Signature \_\_\_\_\_ Date \_\_\_\_\_

**SECTION II: RECORDS TO BE DISCLOSED TO**

1. Name of Recipient (Please Print)	2. Company Name (if applicable)
3. Street Address	4. Phone Number
5. City, State, Zip	6. Please state Recipient's relationship to the employee: *See Section III, Page 2.

LWC-WC-1155 Page 1 of 2 Revised 01/2024

**SECTION III: IF THE RECIPIENT IS A PROSPECTIVE EMPLOYER**

You must certify and sign the following:

I hereby certify the information sought by this authorization is made on an applicant for employment only after a conditional job offer has been made and accepted, or on a current employee for a purpose which is job related and consistent with business necessity. I further certify the information obtained in the authorization will **NOT** be used to discriminate in any manner against the individual who is the subject of this authorization on any basis, in violation of the Americans with Disabilities Act of 1990, 42 U.S.C. §12101, et seq., or any other state or federal law, as applicable.

I am aware of the confidential and privileged nature of an employee's Workers' Compensation records, pursuant to La. R.S. 23: 1293.

Employer's Signature \_\_\_\_\_ Date \_\_\_\_\_

Sworn and subscribed before me this \_\_\_\_\_ day of \_\_\_\_\_, 20\_\_\_\_ at \_\_\_\_\_, Louisiana.

Notary Public's Signature  
Print Name: \_\_\_\_\_  
Notary ID: \_\_\_\_\_  
My commission expires: \_\_\_\_\_

**SECTION IV: IF THE REQUESTOR IS NOT A PARTY TO THE CASE**

You must certify and sign the following:

I hereby certify the information sought by this authorization is made on a claimant who is aware I have requested their records.

I am aware of the confidential and privileged nature of an employee's Workers' Compensation records, pursuant to La. R.S.23: 1293.

Requestor's Signature \_\_\_\_\_ Date \_\_\_\_\_

Sworn and subscribed before me this \_\_\_\_\_ day of \_\_\_\_\_, 20\_\_\_\_ at \_\_\_\_\_, Louisiana.

Notary Public's Signature  
Print Name: \_\_\_\_\_  
Notary ID: \_\_\_\_\_  
My commission expires: \_\_\_\_\_

LWC-WC-1155 Page 2 of 2 Revised 01/2024

**AUTHORITY NOTE:** Promulgated in accordance with R.S. 23:1310.1 and R.S. 23:1293.

**HISTORICAL NOTE:** Promulgated by the Workforce Commission, Office of Workers' Compensation Administration, LR 44:105 (January 2018), amended LR 50:832 (June 2024).

**Title 40**  
**LABOR AND EMPLOYMENT**  
**Part III. Workers' Compensation Second Injury Board**

**Chapter 1. General Provisions**

**§101. Approval of Settlements; Requirements; Computation of Time**

A.1. Requests for approval of the settlement of a third-party claim for settlement amounts less than \$50,000 shall be submitted by facsimile transmission or hand delivery to the offices of the Second Injury Board.

2. Requests for approval of all other settlements may be submitted by United States Postal Services, facsimile transmission or hand delivery to the offices of the Second Injury Board.

B. Requests for approval of the settlement of a third-party claim shall be submitted on SIB Form C.

C. In computing the period of time allowed for response by the Second Injury Board to a request for settlement authority, the date of submission of the request shall not be included. The last day of the period shall not be included, unless it is a legal holiday, in which event the period shall run until the end of the next day which is not a legal holiday. The board shall have three working days, excluding legal holidays, to respond to the request.

D. SIB Form C

**Second Injury Board**

**Request for Settlement Authority  
Third-Party Claims Less Than \$50,000  
R.S. 23:1378(A)(8)(a)(iii)**

All requests must be in **writing**.  
All requests must be **faxed** to 225-219-5968 or **hand delivered** to the Second Injury Fund.  
All **questions** must be answered and submitted with **required attachments**.

<b>Name of Injured Worker:</b>
<b>Name of Workers' Compensation Insurance Carrier and/or Self-Insured Employer:</b>
<b>SIB Claim No:</b>
<b>Weekly Compensation Rate:</b>

What is the total paid to date by the workers' compensation insurance carrier and/or self-insured employer?

- a. Indemnity \_\_\_\_\_
- b. Medical \_\_\_\_\_

What is the third party offer to:

- a. The workers' compensation insurance carrier and or self-insured employer? \_\_\_\_\_
- b. The injured worker? \_\_\_\_\_
- c. Others (specify)? \_\_\_\_\_

Does the workers' compensation insurance carrier and/or self-insured employer anticipate waiving recovery of any portion of the amount paid to the injured worker?	<input type="checkbox"/> Yes* <input type="checkbox"/> No  *If yes, what amount or percentage will be waived? _____
--	---

**In addition to the above responses, the following must be attached:**

- A recent medical report documenting current medical condition.
- A completed settlement evaluation form.

**Not required but recommended:**

Any additional information you care to submit to support your position.

**SIB Form C**

**AUTHORITY NOTE:** Promulgated in accordance with R.S. 23:1378(A)(8)(a)(v).

**HISTORICAL NOTE:** Promulgated by the Department of Labor, Office of Workers' Compensation, Second Injury Board, LR 1:145 (February 1975), amended LR 3:48 (January 1977), LR 3:497 (December 1977), amended by the Department of Employment and Training, Office of Workers' Compensation, Second Injury Board, LR 17:179 (February 1991), amended by Department of Labor, Office of Workers' Compensation, Second Injury Board, LR 32:92 (January 2006).

### **§103. Domicile of Board, Time of Meeting, Special Meetings**

A. The board shall be domiciled in Baton Rouge, Louisiana. It shall hold its regular meeting on the first Thursday of each month. Special meetings may be called upon giving three days' advance notice thereof.

**AUTHORITY NOTE:** Promulgated in accordance with R.S. 23:1372.

**HISTORICAL NOTE:** Promulgated by the Department of Labor, Office of Workers' Compensation, Second Injury Board, LR 1:145 (February 1975), amended LR 3:49 (January 1977), LR 3:497 (December 1977), amended by the Department of Employment and Training, Office of Workers' Compensation, Second Injury Board, LR 17:179 (February 1991).

### **§105. Definitions**

A. By reference, all of the definitions set forth and contained in R.S. 49:950 through 49:966, inclusive, are incorporated herein, and for the purpose of hearings to be held hereunder, the following definitions shall prevail.

*Applicant*—the employer or insurer making claim for reimbursement from the Workers' Compensation Second Injury Fund.

*Board*—the Office of Workers' Compensation, Second Injury Board.

*Hearing*—a hearing called by the board under the authority of R.S. 23:1378, Subsection C.

*Hearing Officer*—the chairman or vice chairman or any other person determined by the board to be qualified to conduct hearings on its behalf.

*Insurer*—the workers' compensation insurance carrier of an employer.

**AUTHORITY NOTE:** Promulgated in accordance with R.S. 23:1376.

**HISTORICAL NOTE:** Promulgated by the Department of Labor, Office of Workers' Compensation, Second Injury Board, LR 1:145 (February 1975), amended LR 3:49 (January 1977), LR 3:497 (December 1977), amended by the Department of Employment and Training, Office of Workers' Compensation, Second Injury Board, LR 17:179 (February 1991).

### **§107. Presentation of Claim for Reimbursement from Second Injury Fund, Timely Filing Thereof**

A. Within one year after the first payment of either compensation or medical benefits, the employer or his insurer, whichever of them makes the payments or becomes liable therefor, shall notify the board in writing of such facts and furnish such other information as may be required for the board to determine if the employer or his insurer is entitled to reimbursement from the Workers' Compensation

Second Injury Fund. No employer, insurer, servicing agent or self-insured association shall be reimbursed unless the board is notified within one year from the date of the first payment of either compensation or medical benefits.

**AUTHORITY NOTE:** Promulgated in accordance with R.S. 23:1376.

**HISTORICAL NOTE:** Promulgated by the Department of Labor, Office of Workers' Compensation, Second Injury Board, LR 1:146 (February 1975), amended LR 3:49 (January 1977), LR 3:497 (December 1977), amended by the Department of Employment and Training, Office of Workers' Compensation, Second Injury Board, LR 17:180 (February 1991), amended by the Department of Labor, Office of Workers' Compensation, Second Injury Board, LR 22:34 (January 1996).

### **§109. Disposition of Claim**

A. The board shall conduct such investigations, order such hearings and take such other actions as it finds necessary to make an intelligent decision on the claim. At least 30 days prior to the date of the board meeting at which a decision on the claim is to be made, all interested parties shall be notified of the following:

1. the date, time, place and purpose of the meeting;
2. that a formal hearing on the claim pursuant to the provisions of R.S. 49:955 may be requested provided such request is made in writing and is received in the office of the board at least 10 days prior to the date of said meeting; and
3. that unless a formal hearing is requested as provided in §109.A.2, the board will render its decision on the claim at said meeting.

B. Where no hearing is requested, the board shall issue a written decision as soon after said meeting as the facts and circumstances will allow. Parties shall be notified by mail of such decision.

**AUTHORITY NOTE:** Promulgated in accordance with R.S. 23:1376.

**HISTORICAL NOTE:** Promulgated by the Department of Labor, Office of Workers' Compensation, Second Injury Board, LR 1:146 (February 1975), amended LR 3:49 (January 1977), LR 3:497 (December 1977), amended by the Department of Employment and Training, Office of Workers' Compensation, Second Injury Board, LR 17:180 (February 1991).

### **§111. Commencement of Hearings**

A. As authorized by R.S. 23:1378.C and these rules of practice and procedure, hearings may be instituted by the board on timely request by the applicant or, at any time, on the board's own motion. No request by the applicant for a hearing shall be effective unless it is made in writing and received in the office of the board at least 10 days prior to the date of the board meeting at which a decision on the claim is to be made as set forth in §109.

**AUTHORITY NOTE:** Promulgated in accordance with R.S. 23:1376.

**HISTORICAL NOTE:** Promulgated by the Department of Labor, Office of Workers' Compensation, Second Injury Board, LR 1:146 (February 1975), amended LR 3:49 (January 1977), LR 3:497 (December 1977), amended by the Department of Employment and Training, Office of Workers' Compensation, Second Injury Board, LR 17:180 (February 1991).

**§115. Notice**

A. The board shall notify the applicant at least 15 days prior to the hearing and such notice shall conform to the requirements of R.S. 49:955.

AUTHORITY NOTE: Promulgated in accordance with R.S. 23:1376.

HISTORICAL NOTE: Promulgated by the Department of Labor, Office of Workers' Compensation, Second Injury Board, LR 1:146 (February 1975), amended LR 3:49 (January 1977), LR 3:497 (December 1977), amended by the Department of Employment and Training, Office of Workers' Compensation, Second Injury Board, LR 17:180 (February 1991).

**§117. Answer or Appearance**

A. The applicant may file an answer or otherwise make an appearance on or before the date fixed for the hearing.

AUTHORITY NOTE: Promulgated in accordance with R.S. 23:1376.

HISTORICAL NOTE: Promulgated by the Department of Labor, Office of Workers' Compensation, Second Injury Board, LR 1:146 (February 1975), amended LR 3:50 (January 1977), LR 3:497 (December 1977), amended by the Department of Employment and Training, Office of Workers' Compensation, Second Injury Board, LR 17:180 (February 1991).

**§119. Leave to Intervene Necessary**

A. Persons, other than the original parties to any proceedings, whose interests are to be directly and immediately affected by the proceedings, shall secure an order from the board or hearing officer appointed by it granting leave to intervene before being allowed to participate; provided that the granting of leave to intervene in any matter or proceeding shall not be construed to be a finding or determination of the board or hearing officer for purposes of court review or appeal.

B. Petitions for leave to intervene must be in writing and must clearly identify the proceeding in which it is sought to intervene. Such petition must set forth the name and address of the petitioner and contain a clear and concise statement of the direct and immediate interest of the petitioner in such proceedings, stating the manner in which such petitioner will be affected by such proceedings, outlining the matters and things relied upon by such petitioner as a basis for his request to intervene in such cause, and, if affirmative relief is sought, the petition must contain a clear and concise statement of relief sought and the basis thereof, together with a statement as to the nature and quality of evidence petitioner will present if such petition is granted.

C. Petitions to intervene and proof of service of copies thereof on all other parties of record shall be filed not less than two days prior to the commencement of the hearing. Thereafter, such petition shall state a substantial reason for such delay; otherwise, such petition will not be considered.

D. If a petition to intervene shows direct and immediate interest in the subject matter of the proceeding or any part thereof and does not unduly broaden the issues, the board may grant leave to intervene or otherwise appear in the proceeding with respect to the matters set out in the intervening petition, subject to such reasonable conditions as may be prescribed. If it appears during the course of a proceeding that an intervenor has no direct or immediate

interest in the proceeding, and the public interest does not require his participation therein, the board may dismiss him from the proceeding.

AUTHORITY NOTE: Promulgated in accordance with R.S. 23:1376.

HISTORICAL NOTE: Promulgated by the Department of Labor, Office of Workers' Compensation, Second Injury Board, LR 1:146 (February 1975), amended LR 3:50 (January 1977), LR 3:497 (December 1977), amended by the Department of Employment and Training, Office of Workers' Compensation, Second Injury Board, LR 17:180 (February 1991).

**§121. Default in Answering or Appearing**

A. In the event of the failure of any respondent to answer or otherwise appear within the time allowed, and provided that the foregoing rules as to service have been complied with, the respondent or respondents so failing to answer or otherwise plead to or to appear, shall be deemed to be in default, and the allegations of the complaint, petition or order to show cause, as the case may be, together with the evidence to support the same, shall be entered into the record and may be taken as true and the order of the board entered accordingly.

AUTHORITY NOTE: Promulgated in accordance with R.S. 23:1376.

HISTORICAL NOTE: Promulgated by the Department of Labor, Office of Workers' Compensation, Second Injury Board, LR 1:146 (February 1975), amended LR 3:50 (January 1977), LR 3:497 (December 1977), amended by the Department of Employment and Training, Office of Workers' Compensation, Second Injury Board, LR 17:181 (February 1991).

**§123. Hearing Procedure**

A. Hearing held under these rules and regulations shall be conducted by the board, or by its designated hearing officer, in accordance with the rules and procedures set forth in R.S. 49:956.

1. The chairman of the board or the vice chairman in the absence of the chairman or the hearing officer assigned to the matter shall announce the title and docket number of the proceedings before the board and direct a reading into the record of the notice of hearing together with the written appearances of the applicant and shall note the subpoenas issued and returns thereon. Attorneys and/or other representatives of the applicant shall be recognized along with the representatives of the board and other proper parties.

2. The applicant shall then present his evidence subject to cross examination by the board and other proper parties in those cases where the applicant requested the hearing be held.

3. The board shall then present its evidence subject to cross examination by the applicant and other proper parties.

4. Where the board has called the hearing on its own motion, the order of presentation of evidence shall be reversed.

5. The board may make an informal disposition of the case by stipulation, agreed settlement, consent order or default.

6. The board shall render its final decision and order in accordance with R.S. 49:958.

AUTHORITY NOTE: Promulgated in accordance with R.S. 23:1376.

HISTORICAL NOTE: Promulgated by the Department of Labor, Office of Workers' Compensation, Second Injury Board, LR 1:146 (February 1975), amended LR 3:50 (January 1977), LR 3:497 (December 1977), amended by the Department of Employment and Training, Office of Workers' Compensation, Second Injury Board, LR 17:181 (February 1991).

### **§125. Finality of Board's Decision**

A. The decision of the board shall be final.

AUTHORITY NOTE: Promulgated in accordance with R.S. 23:1376.

HISTORICAL NOTE: Promulgated by the Department of Labor, Office of Workers' Compensation, Second Injury Board, LR 1:146 (February 1975), amended LR 3:50 (January 1977), LR 3:498 (December 1977), amended by the Department of Employment and Training, Office of Workers' Compensation, Second Injury Board, LR 17:181 (February 1991).

### **§127. Appeal**

A. An appeal from an adverse final decision of the board, as to liability under the Act or the amount of such liability or both, may be taken by the aggrieved party provided such appeal is filed, pursuant to the provisions of R.S. 23:1378.E, within 30 days after the date shown on the written notice of said final decision.

AUTHORITY NOTE: Promulgated in accordance with R.S. 23:1376.

HISTORICAL NOTE: Promulgated by the Department of Labor, Office of Workers' Compensation, Second Injury Board, LR 1:146 (February 1975), amended LR 3:50 (January 1977), LR 3:498 (December 1977), amended by the Department of Employment and Training, Office of Workers' Compensation, Second Injury Board, LR 17:181 (February 1991).

### **§129. Stenographic Record of Hearing**

A. At the expense of and at the written request made not less than five days prior to the date set for the hearing by any person affected by the hearing, the board or the person designated by it to hold the hearing shall cause a full stenographic record of the proceedings to be made by a competent stenographic reporter and, if transcribed, such records shall be made a part of the record of the board of the hearing.

AUTHORITY NOTE: Promulgated in accordance with R.S. 23:1376.

HISTORICAL NOTE: Promulgated by the Department of Labor, Office of Workers' Compensation, Second Injury Board, LR 1:147 (February 1975), amended LR 3:51 (January 1977), LR 3:498 (December 1977), amended by the Department of Employment and Training, Office of Workers' Compensation, Second Injury Board, LR 17:181 (February 1991).

### **§131. Docket**

A. When a hearing is instituted, it shall be assigned a number and entered with the date of its filing on a separate page of docket provided for such purpose. The board shall establish a separate file for each such docketed case, in which shall be systematically placed all papers, pleadings, documents, transcripts, evidence and exhibits pertaining

thereto, and all such items shall have noted thereon the docket number assigned and the date of filing.

AUTHORITY NOTE: Promulgated in accordance with R.S. 23:1376.

HISTORICAL NOTE: Promulgated by the Department of Labor, Office of Workers' Compensation, Second Injury Board, LR 1:146 (February 1975), amended LR 3:49 (January 1977), LR 3:497 (December 1977), amended by the Department of Employment and Training, Office of Workers' Compensation, Second Injury Board, LR 17:181 (February 1991).

## **Chapter 3. Assessments**

### **§301. Assessment; Calculation of Rate**

A. The board shall determine the amount of the total assessment to be collected which shall not exceed 125 percent of the disbursements made from the fund in the preceding fiscal year.

B. The assessment rate shall be calculated by dividing the total assessment by the total workers' compensation benefits as reported to the Office of Workers' Compensation on Form LDOL-WC-1000.

AUTHORITY NOTE: Promulgated in accordance with R.S. 23:1376 and R.S. 23:1377.

HISTORICAL NOTE: Promulgated by the Department of Labor, Office of Workers' Compensation, Second Injury Board, LR 22:35 (January 1996).

### **§303. Assessment; Due Date; Notice**

A. Each reporting entity shall be assessed an amount determined by multiplying the assessment rate times the total reported workers' compensation benefits paid by that entity.

B. The board shall set the date that the assessment shall be due and shall provide notice to all entities assessed at least 30 days prior to such due date.

C. An assessment notice shall be prepared and mailed to each entity filing an annual report and for which an assessment is due. The notice shall be sent certified mail, return receipt requested.

AUTHORITY NOTE: Promulgated in accordance with R.S. 23:1376 and R.S. 23:1377.

HISTORICAL NOTE: Promulgated by the Department of Labor, Office of Workers' Compensation, Second Injury Board, LR 22:35 (January 1996).

### **§305. Assessments—Failure to Pay; Penalties; Collection**

A. Any entity assessed, shall remit the amount of the assessment within 30 days of the date of notice or by the due date set forth in the notice if greater than 30 days. The official United States Postal Department postmark shall be the basis for determining compliance with this requirement.

B. Any entity failing to pay by the due date may be assessed a penalty of 20 percent of the unpaid assessment for each 30 days, or portion thereof, that the assessment remains unpaid.

C. Payments received by the office shall be applied first to penalties assessed and then to the outstanding second injury fund assessment.

LABOR AND EMPLOYMENT

D. The assessment and/or penalties imposed pursuant to this Section shall be pursued for collection by the procedures used for collection of an open account.

AUTHORITY NOTE: Promulgated in accordance with R.S. 23:1376 and R.S. 23:1377.

HISTORICAL NOTE: Promulgated by the Department of Labor, Office of Workers' Compensation, Second Injury Board, LR 22:35 (January 1996).

§307. Ineligibility for Reimbursement

A. Any entity required by law to make an annual payment or payments into the fund, but which has not made such annual payment or payments, shall be ineligible for

reimbursement from the fund for injuries occurring during such period of nonpayment of assessment.

B. Except as provided in R.S. 23:1378(A)(7), any entity that is not required by law to make an annual payment or payments into the fund shall be ineligible for reimbursement from the fund.

AUTHORITY NOTE: Promulgated in accordance with R.S. 23:1376 and R.S. 23:1377.

HISTORICAL NOTE: Promulgated by the Department of Labor, Office of Workers' Compensation, Second Injury Board, LR 22:35 (January 1996).

Chapter 5. Forms

§501. Request for Reimbursement; Form B

LOUISIANA SECOND INJURY BOARD
REQUEST FOR REIMBURSEMENT—FORM B

Table with 5 columns: EMPLOYEE, CARRIER/SELF-INS, EMPLOYER, FROM-TO DATES THIS SUBMISSION, TOTAL WEEKS, TOTAL AMOUNT PAID. Includes summary rows for TOTAL INDEMNITY PAID, TOTAL MEDICAL BENEFITS PAID, TOTAL SETTLEMENT, and TOTAL WC BENEFITS PAID.

THE FOLLOWING DOCUMENTATION MUST BE INCLUDED WITH THE FORM B SUBMISSION

INDEMNITY REIMBURSEMENT REQUEST

Electronic print-out of indemnity payments shall include: date of payment, payee, benefit dates (from/thru), amount paid, and check or ACH number

MEDICAL REIMBURSEMENT REQUEST

A. Electronic print-out of medical payments shall include: date of payment, payee, service dates (from/thru), amount paid, and check or ACH number

B. Copies of all medical bills or EOBs ordered and numbered to correspond with electronic print-out (shall include patient info, provider info, date of service, CPT codes, ICD codes, and amount charged)

SETTLEMENT REIMBURSEMENT REQUEST

Signed petition, Judgement, Receipt and Release, Order from OWCA and a copy of the check or electronic print-out of payment which shall include: date of payment, payee, amount paid, and check or ACH number

THIRD PARTY RECOVERY

IS THERE ANY POTENTIAL TO RECOVER ALL OR A PORTION OF THE BENEFITS PAID TO THE INJURED EMPLOYEE FROM A THIRD PARTY? [ ] YES [ ] NO

I HEREBY CERTIFY THAT I AM AUTHORIZED TO SUBMIT THIS REQUEST AND THE INFORMATION PROVIDED ON THIS FORM IS CORRECT AND ACCURATE TO THE BEST OF MY KNOWLEDGE:

Signature \_\_\_\_\_ Print Name \_\_\_\_\_ Date \_\_\_\_\_
Company: \_\_\_\_\_ Telephone: \_\_\_\_\_



Title 40, Part III

AUTHORITY NOTE: Promulgated in accordance with R.S. 23:1310.1 and R.S. 23:1293.

HISTORICAL NOTE: Promulgated by the Workforce Commission, Office of Workers' Compensation Administration, LR 44:106 (January 2018).

**§502. Louisiana Workers' Compensation Second Injury Board Post-Hire/Conditional Job Offer Knowledge Questionnaire; Form D**

**LOUISIANA WORKERS' COMPENSATION SECOND INJURY BOARD  
POST-HIRE/CONDITIONAL JOB OFFER KNOWLEDGE QUESTIONNAIRE**

**EMPLOYEE:** The intent of this questionnaire is to provide your employer with knowledge about any pre-existing medical condition or disability which may entitle your employer to reimbursement from the Louisiana Workers' Compensation Second Injury Board in the event you suffer an on-the-job injury.<sup>1</sup> This reimbursement in no way affects the benefits owed to you by your employer or its insurance company under the Louisiana Workers' Compensation Act. La. R.S. 23:1021-1361. However, your failure to answer truthfully and/or correctly to any of the question on this questionnaire may result in a forfeiture of your workers' compensation benefits.

In order for your employer to be considered for reimbursement from the Second Injury Board, it has to show that it knowingly hired or retained you with a pre-existing medical condition or disability. To establish its knowledge, your employer is requesting that this questionnaire be completed.

**INSTRUCTIONS:** Please answer ALL questions completely. If a response requires an explanation, please provide a brief description on the Explanation Page. If you have any questions or need help in answering the questions on this form, please ask for assistance from the Employer Representative signing this form.

**NOTE:** Since this questionnaire contains medical information, you can request that the form be kept CONFIDENTIAL and not made part of your personnel file. Please let your employer know that you want the completed questionnaire placed in a sealed folder for confidentiality purposes.

**EMPLOYEE WARNING**

**FAILURE TO ANSWER TRUTHFULLY AND/OR CORRECTLY TO ANY OF THE QUESTIONS ON THIS FORM MAY RESULT IN A FORFEITURE OF YOUR WORKERS' COMPENSATION BENEFITS UNDER La. R.S. 23:1208.1.**

Employee Signature: \_\_\_\_\_ Date: \_\_\_\_\_

Employer Representative Signature: \_\_\_\_\_ Date: \_\_\_\_\_

Employer Name: \_\_\_\_\_

Employee Name: \_\_\_\_\_

Date of Birth (mm/dd/yyyy): \_\_\_\_\_ Male:  Female:

Soc. Sec. # (last 4 digits only): \_\_\_\_\_

Home Address: \_\_\_\_\_

Telephone Number: ( \_\_\_\_\_ ) \_\_\_\_\_

**Disease and Other Medical Conditions you currently have or have ever had.**

For all conditions that you check yes, write a brief explanation on the Explanation Page.

[Please check the appropriate box next to each. Every illness/injury requires a Yes (Y) or No (N) answer.]

\_\_\_\_\_

<sup>1</sup> Under La. R.S. 23:1371(A), the purpose of the Second Injury Board is to encourage the employment, re-employment, or retention of employees who have a permanent partial disability.



**EXPLANATION PAGE**

Please use the space below to explain the illnesses and/or conditions that you checked a Yes (Y) **or** any other medical conditions that may not be listed on this form. Ask your employer for additional copies of this page if needed.

CONDITION: \_\_\_\_\_ Year Diagnosed (approx): \_\_\_\_\_

Are you still treating for this condition? Yes  No

Are you taking medication for this condition? Yes  No

Do you have any permanent restrictions for this condition? Yes  No

Brief Explanation: \_\_\_\_\_

CONDITION: \_\_\_\_\_ Year Diagnosed (approx): \_\_\_\_\_

Are you still treating for this condition? Yes  No

Are you taking medication for this condition? Yes  No

Do you have any permanent restrictions for this condition? Yes  No

Brief Explanation: \_\_\_\_\_

CONDITION: \_\_\_\_\_ Year Diagnosed (approx): \_\_\_\_\_

Are you still treating for this condition? Yes  No

Are you taking medication for this condition? Yes  No

Do you have any permanent restrictions for this condition? Yes  No

Brief Explanation: \_\_\_\_\_

CONDITION: \_\_\_\_\_ Year Diagnosed (approx): \_\_\_\_\_

Are you still treating for this condition? Yes  No

Are you taking medication for this condition? Yes  No

Do you have any permanent restrictions for this condition? Yes  No

Brief Explanation: \_\_\_\_\_

Employee Signature: \_\_\_\_\_ Date: \_\_\_\_\_

Employer Representative: \_\_\_\_\_ Date: \_\_\_\_\_

LABOR AND EMPLOYMENT

Please answer the following questions.

- 1. Has any doctor ever restricted your activities? Yes [ ] No [ ]

If "Yes," please list the restrictions: \_\_\_\_\_
Were the restrictions: Permanent \_\_\_\_\_ Temporary \_\_\_\_\_
Are your activities currently restricted? Yes [ ] No [ ]
What is the medical condition for which you have restrictions? \_\_\_\_\_

- 2. Are you presently treating with a doctor, chiropractor, psychiatrist, psychologist or other health-care provider? Yes [ ] No [ ]

Please list the medical condition being treated: \_\_\_\_\_
Doctor's Name: \_\_\_\_\_ Specialty: \_\_\_\_\_
Doctor's Address: \_\_\_\_\_

- 3. If you are currently taking prescription medication other than those listed on the Explanation Page, please complete the requested information below.

Medication: \_\_\_\_\_ Prescribing Doctor: \_\_\_\_\_
Medication: \_\_\_\_\_ Prescribing Doctor: \_\_\_\_\_

- 4. Have you ever had an on the job accident? Yes [ ] No [ ]

If you answered "YES," please provide the date for each injury and the nature of the injury:
\_\_\_\_\_
How long were you on compensation? \_\_\_\_\_
Name of Employer: \_\_\_\_\_

- 5. Has a doctor recommended a surgical procedure, which has not been completed prior to this date, including but not limited to knee, hip or shoulder replacement? Yes [ ] No [ ]

If you answered YES, please provide:
Recommended surgery: \_\_\_\_\_
Approximate date of recommendation: \_\_\_\_\_
Doctor's Name: \_\_\_\_\_ Specialty: \_\_\_\_\_
Doctor's Address: \_\_\_\_\_

Employee Signature: \_\_\_\_\_ Date: \_\_\_\_\_
Employer Representative: \_\_\_\_\_ Date: \_\_\_\_\_

**TO BE COMPLETED BY EMPLOYEE**

**EMPLOYEE WARNING**

**FAILURE TO ANSWER TRUTHFULLY AND/OR CORRECTLY TO ANY OF THE QUESTIONS ON THIS FORM MAY RESULT IN A FORFEITURE OF ANY AND ALL WORKERS COMPENSATION BENEFITS UNDER La. R.S. 23:1208.1.**

I have completed this form honestly and to the best of my knowledge. I understand that providing false information or omitting pertinent information could result in loss of my workers compensation benefits should I become injured on the job.

Employee Signature: \_\_\_\_\_ Date: \_\_\_\_\_

Employee Printed Name: \_\_\_\_\_

**TO BE COMPLETED BY EMPLOYER REPRESENTATIVE**

**EMPLOYER WARNING**

**PURSUANT TO La. R.S. 23:1208 OF THE LOUISIANA WORKERS' COMPENSATION ACT, IT SHALL BE UNLAWFUL FOR A PERSON, FOR THE PURPOSE OF OBTAINING OR DEFEATING ANY BENEFIT PAYMENT UNDER THE PROVISIONS OF THIS CHAPTER, EITHER FOR HIMSELF OR FOR ANY OTHER PERSON, TO WILLFULLY MAKE A FALSE STATEMENT OR REPRESENTATION. PENALTIES FOR VIOLATIONS INCLUDE IMPRISONMENT, FINES, AND/OR THE FORFEITURE OF BENEFITS.**

You must certify the following:

1. That I am an authorized representative of the employer designated to obtain and review the information provided by the employee on this questionnaire;
2. That I have provided the employee with as many copies of the Explanation Page as needed and have confirmed the number of and labeled the pages of this questionnaire;
3. That I have provided assistance to the employee (if requested) in responding to the questions on this questionnaire;
4. That the information sought by this authorization is made on an applicant for employment only after a conditional job offer has been made and accepted, or on a current employee; and
5. That the information obtained in the authorization will **NOT** be used to discriminate in any manner against the individual who is the subject of this authorization on any basis, in violation of the Americans with Disabilities Act of 1990, 42 U.S.C. §12101, *et seq.*, or any other state or federal law;
6. That if requested, a photocopy of this fully completed and signed form will be provided to the employee.

Employer Representative Signature: \_\_\_\_\_ Date: \_\_\_\_\_

Employer Representative Printed Name: \_\_\_\_\_ Title: \_\_\_\_\_

PAGE \_\_\_\_\_ OF \_\_\_\_\_

**SIB FORM D (10/17)**

AUTHORITY NOTE: Promulgated in accordance with R.S. 23:1291 and R.S. 23:1378.

HISTORICAL NOTE: Promulgated by the Workforce Commission, Office of Workers' Compensation Administration, LR 44:1097 (June 2018).



**Title 40**  
**LABOR AND EMPLOYMENT**  
**Part IV. Employment Security**  
**Subpart 1. Board of Review**

**Chapter 1. General Provisions**

**§101. Office and Officers of the Board of Review**

A. The Office of the Board of Review, hereinafter referred to as "the board," shall be domiciled in the Office of Regulatory Services Administrative Office Building in Baton Rouge, Louisiana.

B. The board shall elect a chairman, vice-chairman and secretary, from its membership, all of whom shall serve at the pleasure of the majority of the board. The chairman shall not be denied any right of membership.

AUTHORITY NOTE: Promulgated in accordance with Act 97 of 1936 as amended.

HISTORICAL NOTE: Promulgated by the Department of Labor, Office of Employment Security, LR 15:485 (June 1989), amended by the Department of Employment and Training, Board of Review, LR 17:36 (January 1991).

**§103. Time and Place of Meeting of the Board**

A. All meetings of the board shall be called by the chairman or by a majority of the board. The chairman shall notify the members of the board of any meeting in writing at least three days in advance, unless such notice is waived by the members. All meetings shall be held at the office of the board, or at any place within the state designated in the call.

AUTHORITY NOTE: Promulgated in accordance with Act 97 of 1936 as amended.

HISTORICAL NOTE: Promulgated by the Department of Labor, Office of Employment Security, LR 15:485 (June 1989), amended by the Department of Employment and Training, Board of Review, LR 17:36 (January 1991).

**§105. Quorum**

A. Except as otherwise expressly provided in these rules, two members of the board shall constitute a quorum, until January 1, 1989, at which time three members will constitute a quorum, as per Act R.S. 23:1652 of the 1988 Regular Session of Louisiana Legislature. In the absence of the chairman, the vice-chairman shall act as chairman.

AUTHORITY NOTE: Promulgated in accordance with Act 97 of 1936 as amended.

HISTORICAL NOTE: Promulgated by the Department of Labor, Office of Employment Security, LR 15:485 (June 1989), amended by the Department of Employment and Training, Board of Review, LR 17:36 (January 1991).

**§107. Computation of Time—Saturdays, Sundays and Holidays**

A. Whenever these rules prescribe a time for the performance of any act, Saturdays, Sundays and legal

holidays (half holiday is considered a legal holiday) in the state of Louisiana shall count as any other days, except that when the time prescribed for the performance of an act expired on a Saturday, Sunday or a legal holiday in Louisiana, such time shall extend to and include the next succeeding day that is not a Saturday, Sunday or such legal holiday, provided that, when the time for performing any act is prescribed by statute, nothing in these rules shall be deemed to be a limitation or extension of the statutory time fixed.

AUTHORITY NOTE: Promulgated in accordance with Act 97 of 1936 as amended.

HISTORICAL NOTE: Promulgated by the Department of Labor, Office of Employment Security, LR 15:485 (June 1989), amended by the Department of Employment and Training, Board of Review, LR 17:36 (January 1991).

**§109. Appeals to the Appeals Tribunal and Board of Review**

A. The party appealing from the agency's initial determination shall file a written appeal, setting forth information required therein within 15 days after date notification was given or was mailed to his last known address.

B. It is hereby further provided that any communication written by claimant or employer to the Louisiana Workforce Commission or the board disputing the determination or appeal decision may be accepted as an appeal, provided said written communication is received by any office of the Louisiana Workforce Commission or by the board within 15 days after notification, was given or was mailed to his last known address.

C. Legal holidays and days on which the Louisiana Workforce Commission is closed shall not serve to extend the delay periods specified in R.S. 23:1629 and R.S. 23:1630.

D. Proof of the timeliness of mailing a request for appeal shall be shown only by the date indicated on the electronic transmission, by a legible official United States postmark, or by official receipt or certificate from the United States Postal Service made at the time of mailing which indicates the date thereof. In the event that the date of the electronic transmission or postmark is absent, illegible, or manifestly incorrect, the date that the request is received in the Appeals Tribunal or Board of Review office shall determine whether the appeal was timely filed.

AUTHORITY NOTE: Promulgated in accordance with R.S. 23:1471-1713.

**HISTORICAL NOTE:** Promulgated by the Department of Labor, Office of Employment Security, LR 15:485 (June 1989), amended by the Department of Employment and Training, Board of Review, LR 17:36 (January 1991), amended by the Workforce Commission, Office of Unemployment Insurance, LR 39:2312 (August 2013), repromulgated LR 39:3101 (November 2013).

### **§111. Notice of Hearing**

A. A notice of hearing shall be mailed to all parties to the appeal at least seven days prior to the date of the hearing, specifying the place, date and time of the hearing.

**AUTHORITY NOTE:** Promulgated in accordance with R.S. 23:1631.

**HISTORICAL NOTE:** Promulgated by the Department of Labor, Office of Employment Security, LR 15:486 (June 1989), amended by the Department of Employment and Training, Office of Employment Security, LR 17:36 (January 1991), amended by the Workforce Commission, Office of Unemployment Insurance, LR 40:374 (February 2014).

### **§113. Postponements, Continuances, Reopenings, and Rehearings**

#### A. Continuances or Postponements

1. A scheduled hearing may be postponed or continued by the administrative law judge for good cause, either upon his own motion or upon a showing of good cause by written request of a party, submitted to the administrative law judge whose name and address appear on the notice of hearing. Written notice of the time and place of a postponed or continued hearing shall be given to the parties or their named representatives.

2. The administrative law judge shall provide written denial to any party whose written request for postponement or continuance is received after his decision has been mailed. The requesting party shall also be provided written notice of his right either to file written request of a reopening of hearing before the administrative law judge within seven days from the date of mailing of the decision on the claim or to file further appeal to the Board of Review under §109 and §125. The untimely request for postponement or continuance shall not itself be treated as an appeal of the decision to the Board of Review. An appeal may also be timely filed by a party before the Board of Review under §109 and §125 after a written response to the request for reopening is issued by the administrative law judge.

3. Any such request of a party and response of the administrative law judge shall be incorporated in the case file.

B. Non-Appearance of Appellant. If the appellant, who is the party who files the appeal before the Appeals Tribunal, fails to appear or fails to be available to participate in a telephone hearing within 15 minutes after the scheduled hearing time, the administrative law judge shall order the appellant in default and issue a dismissal of appeal. In such event, the agency determination shall become the final decision. Written notice of default of the appellant and dismissal of the appeal shall be mailed to the parties. The appellant either may file a written request for reopening before the administrative law judge, with a showing of good

cause, within seven days of the date of mailing of the dismissal decision or may file an appeal before the board of review under §109 and §125. If such appellant is denied a reopening by the administrative law judge, any such request shall be forwarded to the board of review as an appeal as of the date of the written request for reopening. If it is determined by the administrative law judge on reopening or by the board of review on appeal that the appellant has shown good cause for his nonappearance, the dismissal shall be vacated and a new hearing on the merits shall be scheduled.

C. Non-Appearance or Late Appearance of Appellee. If the appellee, who is the party whose agency determination is being appealed by another party before the appeals tribunal, fails to appear at the scheduled hearing time of an in-person hearing, or fails to be available to receive the telephone call to participate in a scheduled telephone hearing at the scheduled hearing time, the administrative law judge shall proceed to conduct the hearing and issue a decision on the merits based upon the administrative record and any evidence and testimony presented by the appellant. The appellee may either file a written request for reopening before the administrative law judge, with a showing of good cause, within seven days of the date of mailing of the decision or may file an appeal before the board of review under §109 and §125. If such appellee is denied a reopening by the administrative law judge, any such request shall be forwarded to the board of review as an appeal as of the date of the written request for reopening. If it is determined by the administrative law judge on reopening or by the board of review on appeal that the appellee has shown good cause for his non-appearance, the decision shall be vacated, and a new hearing on the merits shall be scheduled.

#### D. Good Cause for Reopening or Rehearing

1. The administrative law judge or the board of review shall make a determination of good cause for failure to appear only if the written request for reopening or the appeal filed by the party contains a statement of the reason(s) for his failure to act in a timely manner and reasonably justifies a finding of good cause to excuse such failure.

2. To determine whether good cause has been shown in a request for reopening or in an appeal to excuse the failure of a party to appear, the administrative law judge and the board of review shall consider any relevant factors, including, but not limited to:

- a. reasonably prudent behavior;
- b. untimely receipt of notice;
- c. administrative error;
- d. reasons beyond control or avoidance;
- e. reasons unforeseen;
- f. timely effort to request continuance;
- g. physical disabilities;
- h. degree of untimeliness; or



i. prejudice to parties.

3. Failure to provide timely notice of change or correction of address shall not establish good cause for failure to appear, unless the party satisfactorily demonstrates his reasonable belief in his request or appeal that such notice was not needed or had been provided.

4. The basis of any determination by the administrative law judge or the board of review relating to good cause must be provided in the written response or decision. The fulfillment of each of the above factors is not required in any such response or decision for the establishment of good cause for failure to appear.

5. A written request for reopening before the administrative law judge may be filed within seven days of the date of mailing of his decision or an appeal to the board of review may be filed under §109 and §125 by any party for admission of additional evidence upon the showing of good cause that any such evidence is newly discovered or was unavailable or unknown at the time of the hearing.

E. Terminology. The term party or parties, as used in these rules, shall mean the claimant and the employer or any legal or designated representative thereof, including the administrator in those appeals in which he is specified as a party under R.S. 23:1629.

**AUTHORITY NOTE:** Promulgated in accordance with R.S. 23:1471-1713.

**HISTORICAL NOTE:** Promulgated by the Department of Labor, Office of Employment Security, LR 15:486 (June 1989), amended by the Department of Employment and Training, Office of Employment Security, LR 17:36 (January 1991), repromulgated by the Department of Labor, Office of Employment Security, Board of Review LR 23:76 (January 1997), amended by the Workforce Commission, Office of Unemployment Insurance, LR 39:2312 (August 2013), repromulgated LR 39:3102 (November 2013).

**§115. Conduct of Hearing before Administrative Law Judge**

A. The administrative law judge shall preside over the hearing. All testimony shall be given under oath or affirmation. The administrative law judge shall have the right to question and cross-examine all witnesses. Each party to the appeal, or their representatives, shall have the right to question their own witnesses and to cross-examine the opposing parties and witnesses.

B. Only testimony pertinent to the issue involved in the appeal shall be admitted by the administrative law judge.

C. Technical rules of evidence need not be complied with so long as all parties are given an opportunity to fully present their case.

D. Hearsay testimony is admissible, but may only be considered by the administrative law judge in making his decision to substantiate or corroborate other direct evidence.

E. Expunged criminal records shall not be deemed admissible evidence.

**AUTHORITY NOTE:** Promulgated in accordance with Act 97 of 1936 as amended.

**HISTORICAL NOTE:** Promulgated by the Department of Labor, Office of Employment Security, LR 15:486 (June 1989), amended by the Department of Employment and Training, Office of Employment Security, LR 17:37 (January 1991).

**§117. Authority to Separate Witnesses (Placing Witnesses under the Rule)**

A. Either party or the administrative law judge may require that a witness may be excluded from the hearing room. Witnesses who are excluded from the hearing shall be instructed not to discuss the case with anyone except the attorney or representative of the party on whose behalf they have been called. This shall not apply to the parties to the appeal or their attorney or representative.

**AUTHORITY NOTE:** Promulgated in accordance with Act 97 of 1936 as amended.

**HISTORICAL NOTE:** Promulgated by the Department of Labor, Office of Employment Security, LR 15:486 (June 1989), amended by the Department of Employment and Training, Office of Employment Security, LR 17:37 (January 1991).

**§119. Additional Testimony**

A. The administrative law judge may take such additional testimony as he deems necessary for a fair determination of the issues upon notice to all parties to the appeal as provided in §111.

**AUTHORITY NOTE:** Promulgated in accordance with Act 97 of 1936 as amended.

**HISTORICAL NOTE:** Promulgated by the Department of Labor, Office of Employment Security, LR 15:486 (June 1989), amended by the Department of Employment and Training, Office of Employment Security, LR 17:37 (January 1991).

**§121. Stipulation of Facts**

A. Parties to an appeal, with consent of the administrative law judge, may jointly stipulate the facts, in advance, in writing, or at the hearing. The administrative law judge may decide the appeal on the basis of the stipulation or, if he deems necessary, he may hold a hearing and take further testimony after giving notice as provided in §111.

**AUTHORITY NOTE:** Promulgated in accordance with Act 97 of 1936 as amended.

**HISTORICAL NOTE:** Promulgated by the Department of Labor, Office of Employment Security, LR 15:486 (June 1989), amended by the Department of Employment and Training, Office of Employment Security, LR 17:37 (January 1991).

**§123. Decision of Administrative Law Judge**

A. The administrative law judge shall render a decision as soon as reasonably possible on all issues involved. This decision will be in writing and will contain a statement of the facts found, the reasons therefor, and the conclusion reached. Copies of the administrative law judge's decision will be mailed to the parties to the proceeding, as defined in §113.

**AUTHORITY NOTE:** Promulgated in accordance with Act 97 of 1936 as amended.

**HISTORICAL NOTE:** Promulgated by the Department of Labor, Office of Employment Security, LR 15:486 (June 1989), amended by the Department of Employment and Training, Office of Employment Security, LR 17:37 (January 1991).

**§125. Appeals to Board**

A. Any party aggrieved by the decision of the administrative law judge may, within the time and the manner specified in §109, file an application for appeal to the board.

B. Upon receipt thereof, the board may, on the basis of the evidence previously submitted to the administrative law judge, affirm, modify, or reverse the findings and conclusions of the administrative law judge.

C. If the board deems it necessary to take additional evidence or decides to hear oral argument, a hearing shall be fixed and all parties shall be notified thereof as provided in §111.

D. The board may, at its discretion, remand the case to the administrative law judge for the taking of such additional evidence as the board may direct. Notice thereof shall be given as provided in §111.

E. Either party may submit written briefs to the board for its consideration at any time before the case is taken under advisement.

AUTHORITY NOTE: Promulgated in accordance with Act 97 of 1936 as amended.

HISTORICAL NOTE: Promulgated by the Department of Labor, Office of Employment Security, LR 15:487 (June 1989), amended by the Department of Employment and Training, Office of Employment Security, LR 17:37 (January 1991).

**§127. Notification of Appeal**

A. All applications for appeals shall be acknowledged and the opposing party shall be duly notified.

AUTHORITY NOTE: Promulgated in accordance with Act 97 of 1936 as amended.

HISTORICAL NOTE: Promulgated by the Department of Labor, Office of Employment Security, LR 15:487 (June 1989), amended by the Department of Employment and Training, Office of Employment Security, LR 17:38 (January 1991).

**§129. Decision of the Board**

A. The board shall, as soon as possible, announce its decision, including its findings of fact and conclusions in support thereof, or it may adopt the decision of the administrative law judge as its own.

B. The decision shall be in writing and shall be signed by the members of the board who considered the appeal. If the decision is not unanimous, the decision of the majority shall control. Dissenting opinions may be filed setting forth the reason for dissent. Copies of the board's decision will be mailed to the parties as defined in §113.

AUTHORITY NOTE: Promulgated in accordance with Act 97 of 1936 as amended.

HISTORICAL NOTE: Promulgated by the Department of Labor, Office of Employment Security, LR 15:487 (June 1989), amended by the Department of Employment and Training, Office of Employment Security, LR 17:38 (January 1991).

**§131. Issuance of Subpoenas**

A. Requests for subpoenas must be submitted in writing. They shall contain the name and address of the witness and a

statement of what is intended to be proven by his or her testimony. Such request must be received by the administrative law judge or board at least 72 hours prior to the time for which the hearing is scheduled. If a request is timely made but service is not perfected or cannot be perfected in time for the appearance of the witness, this shall be grounds for a postponement.

AUTHORITY NOTE: Promulgated in accordance with Act 97 of 1936 as amended.

HISTORICAL NOTE: Promulgated by the Department of Labor, Office of Employment Security, LR 15:487 (June 1989), amended by the Department of Employment and Training, Office of Employment Security, LR 17:38 (January 1991).

**§133. Representation before the Administrative Law Judge and Board**

A. Any individual may appear for himself, and/or may be represented by counsel or other duly authorized agent, in any proceeding before the administrative law judge or board. Any partnership may be represented by any of its members or a duly authorized representative. Any corporation or association may be represented by an officer or a duly authorized representative.

AUTHORITY NOTE: Promulgated in accordance with Act 97 of 1936 as amended.

HISTORICAL NOTE: Promulgated by the Department of Labor, Office of Employment Security, LR 15:487 (June 1989), amended by the Department of Employment and Training, Office of Employment Security, LR 17:38 (January 1991).

**§135. Disqualification of Representative**

A. The administrative law judge or the board may refuse to allow any person to represent others in any proceeding before them whom they find guilty of contumacy or unethical conduct, or who intentionally and repeatedly fails to observe the pertinent provisions of the Louisiana Employment Security Law, R.S. 23:1471, et seq.

AUTHORITY NOTE: Promulgated in accordance with Act 97 of 1936 as amended.

HISTORICAL NOTE: Promulgated by the Department of Labor, Office of Employment Security, LR 15:487 (June 1989), amended by the Department of Employment and Training, Office of Employment Security, LR 17:38 (January 1991).

**§137. Availability of Rules**

A. Copies of these rules shall be made available at all area offices of the Office of Regulatory Services and may be inspected by any interested party. Copies of these rules may be requested from the board by parties having need thereof.

AUTHORITY NOTE: Promulgated in accordance with Act 97 of 1936 as amended.

HISTORICAL NOTE: Promulgated by the Department of Labor, Office of Employment Security, LR 15:487 (June 1989), amended by the Department of Employment and Training, Office of Employment Security, LR 17:38 (January 1991).

**Chapter 3. Employment Security Law****§301. Authority**

A. By virtue of the authority vested in the administrator of the Louisiana Workforce Commission of the state of

Louisiana by the Louisiana Employment Security Law, R.S. 23:1471-1713 (Act 97 of 1936), as amended, and in order to establish uniform procedure under said law, the following regulations have been and are adopted and prescribed and all other regulations now in effect are hereby rescinded, but remain in full force and effect relative to all matters arising prior to the effective date of the hereinafter prescribed and adopted regulations.

**AUTHORITY NOTE:** Promulgated in accordance with R.S. 23:1471-1713.

**HISTORICAL NOTE:** Promulgated by the Department of Labor, Office of Employment Security, LR 15:487 (June 1989), amended by the Department of Employment and Training, Office of Employment Security, LR 17:38 (January 1991), amended by the Workforce Commission, Office of Unemployment Insurance, LR 39:2314 (August 2013).

### **§303. Training of Administrative Law Judges**

A. Prior to participation in any claim resolution, newly hired administrative law judges will participate in web-based and/or in-person training on: agency policy and precedent, benefits analysis, the unemployment insurance system, the appeals process, and the proper methods for conducting hearings and writing decisions according to federal quality standards.

**AUTHORITY NOTE:** Promulgated in accordance with R.S. 23:1653 et seq.

**HISTORICAL NOTE:** Promulgated by the Workforce Commission, Office of Unemployment Insurance Administration, LR 40:374 (February 2014).

### **§305. Posting of Cards, Statements and Material Relating to the Louisiana Employment Security Law, R.S. 23:1471-1713 as Amended**

A. All employers shall follow the instructions issued them by the administrator relative to the posting and maintaining in prominent locations in their places of business where they may be read by the public and all workers, such cards, statements and materials relating to unemployment compensation as are prescribed by the administrator.

**AUTHORITY NOTE:** Promulgated in accordance with R.S. 23:1471-1713.

**HISTORICAL NOTE:** Promulgated by the Department of Labor, Office of Employment Security, LR 15:488 (June 1989), amended by the Department of Employment and Training, Office of Employment Security, LR 17:39 (January 1991).

### **§307. Contributions, Interest, Mailing Date of Contributions and Contribution Reports**

A. **Accrual and Due Date of Contributions.** Contributions due on wages paid shall become due and shall be paid on or before the last day of the month following the calendar quarter in which such contributions accrue.

B. **Interest.** Interest prescribed by law on all overdue contributions shall accrue on or after the day following the due date on any contribution payments up to and including the date of payment.

C. **Accrual and Due Date of Contributions by Employers Who Become Subject within the Calendar Year**

1. With respect to contributions due on wages paid, the first contribution payment of an employing unit which becomes an employer under the Louisiana Employment Security Law at any time during the calendar year, shall become due on, and shall be paid on or before the last day of the month following the calendar quarter in which such employing unit becomes an employer.

2. The first contribution payment of an employer becoming liable during a calendar year shall include all contributions with respect to wages paid for employment occurring on and after January 1 of the calendar year up to and including the end of the calendar quarter in which the employing unit becomes an employer. The first contribution payment of an employing unit which (voluntarily) elects with the written approval of the administrator to become an employer shall accrue at the end of the calendar quarter with respect to wages for employment occurring on and after the date on which such election was approved, and shall be due and paid on or before the last day of the calendar month following the calendar quarter during which the conditions of becoming an employer are satisfied.

**AUTHORITY NOTE:** Promulgated in accordance with R.S. 23:1471-1713.

**HISTORICAL NOTE:** Promulgated by the Department of Labor, Office of Employment Security, LR 15:488 (June 1989), amended by the Department of Employment and Training, Office of Employment Security, LR 17:39 (January 1991), amended by the Workforce Commission, Office of Unemployment Insurance, LR 39:1834 (July 2013).

### **§311. Instructions on Reports**

A. Each employing unit shall comply with instructions pertaining to the contents and due date of any report issued or required by the administrator.

**AUTHORITY NOTE:** Promulgated in accordance with R.S. 23:1471-1713.

**HISTORICAL NOTE:** Promulgated by the Department of Labor, Office of Employment Security, LR 15:488 (June 1989), amended by the Department of Employment and Training, Office of Employment Security, LR 17:39 (January 1991).

### **§313. Records**

A. Each employing unit shall establish records with respect to employment performed for it as hereinafter indicated and shall preserve such records, including those now existing for a period of not less than five years after the calendar year in which the remuneration with respect to such services was paid.

1. For each worker:

a. name;

b. Social Security number;

c. place in which his services are performed, or if there is no one such place, then his base of operations;

d. date on which he was hired, rehired, or returned to work after temporary lay-off and date separated from work;

e. his remuneration paid for employment occurring on or after July 1, 1940, and period from which payable, showing separately:

- i. cash remuneration, including special payments;
- ii. reasonable cash value or remuneration in any medium other than cash, including special payments; and
- iii. special payments, included in §313.A.1.a and b (any payments such as bonuses, gifts, etc.) and the year in which the services for which the payments were made were rendered;

f. amounts paid him as allowance or reimbursement for traveling or other business expenses, and period for which payable; and

g. if he is paid:

- i. on a salary basis, his wage rate, and period covered by such rate;
- ii. on fixed hourly basis, his hourly rate and customary scheduled hours per week;
- iii. on fixed daily basis, his daily rate and customary scheduled days per week; or
- iv. on piece rate or other variable pay basis, method by which his wages are computed.

2. General:

- a. beginning and ending dates of each pay period;
- b. total amount of remuneration paid in any pay period for employment occurring on or after July 1, 1940.

3. Records shall be maintained in such form that it would be possible from and inspection thereof to determine:

- a. earnings by weeks of partial unemployment as defined in §327.B;
- b. whether any week of partial unemployment claimed by an individual is in fact a week of less than full-time work; and
- c. time lost, due to unavailability for work by each worker who may be eligible for partial benefits.

AUTHORITY NOTE: Promulgated in accordance with R.S. 23:1471-1713.

HISTORICAL NOTE: Promulgated by the Department of Labor, Office of Employment Security, LR 15:489 (June 1989), amended by the Department of Employment and Training, Office of Employment Security, LR 17:40 (January 1991).

**§315. Reserved.**

**§317. Employer Registration When Required**

A. Any employing unit who pays wages to a worker within this state, or who pays wages to a worker for work performed in this state, or pays wages to a worker who is domiciled in this state, must, within 30 days of the first payment to a worker in this state or for work performed in this state, register as an employer with the Louisiana Workforce Commission.

B. The employing unit must register regardless of whether it:

- 1. has registered in another state;
- 2. files contribution reports in another state;
- 3. believes it is an employer subject to the Louisiana Employment Security Law;
- 4. pays contributions in another state; or
- 5. believes its workers are independent contractors.

C. After the employing unit has registered, the Louisiana Workforce Commission will determine whether the employing unit is an “employer” within the meaning of R.S. 23:1472(11) and whether the individual(s) to whom wages were paid are “employees” within the meaning of R.S. 23:1472(12).

AUTHORITY NOTE: Promulgated in accordance with R.S. 23:1491 and R.S. 23:1513.

HISTORICAL NOTE: Promulgated by the Workforce Commission, Office of Unemployment Insurance Administration, LR 40:549 (March 2014).

**§319. Identification of Workers**

A. Each worker engaged in employment for an employer shall procure a federal Social Security account number and report it to every employer by whom he is employed.

B. Each employer shall ascertain the federal Social Security account number of each worker employed by him in employment subject to the Louisiana Employment Security Law. Each employer shall report the federal Social Security account number card in any report required by the administrator with respect to a worker.

AUTHORITY NOTE: Promulgated in accordance with R.S. 23:1471-1713.

HISTORICAL NOTE: Promulgated by the Department of Labor, Office of Employment Security, LR 15:489 (June 1989), amended by the Department of Employment and Training, Office of Employment Security, LR 17:40 (January 1991).

**§321. Reserved.**

**§323. Separation Notices**

A. Individual Separation Notices

1. Under Conditions Which May Disqualify. Whenever a worker is separated from his employment permanently or for an indefinite period or for an expected duration of seven or more days, under conditions which may disqualify him for benefits pursuant to the provisions of R.S. 23:1601, his employer shall within three days after such separation give him, or if such delivery is impossible or impracticable, mail to his last known address a separation notice alleging disqualification on which the employer has entered the required information. Within the same period of time, the employer shall send a copy of such separation notice, certified by himself or his duly authorized agent, to the administrator.

B. Mass Separation Notices

1. In the event of a separation of 50 or more individuals by an employer for the same reason and about the same time, the employer shall notify the administrator of such separation. Upon receipt of such notice, the administrator shall make full investigation.

#### C. Labor Dispute Notices

1. In case of a separation due to a labor dispute, the employer shall within three days after such separation file with the administrator a notice setting forth the existence of such a dispute and the approximate number of workers affected.

2. Upon request by the administrator, such employer shall furnish the names of workers ordinarily attached to the department or the establishment where unemployment is alleged to be caused by a labor dispute.

**AUTHORITY NOTE:** Promulgated in accordance with R.S. 23:1471-1713.

**HISTORICAL NOTE:** Promulgated by the Department of Labor, Office of Employment Security, LR 15:489 (June 1989), amended by the Department of Employment and Training, Office of Employment Security, LR 17:40 (January 1991), amended by the Workforce Commission, Office of Unemployment Insurance, LR 39:2314 (August 2013).

### §324. Reply to Notice of Eligibility

A. When the employer or the employer's agent receives the notice specified by R.S. 23:1624 of a claimant's eligibility for benefits or other notice that an application for benefits has been made; the employer or employer's agent shall, within the time specified in the notice examine the notice against the claimant's record and shall reply to the notice. The reply shall either protest or indicate no known cause to protest a decision granting eligibility or otherwise shall inform the department of any known facts bearing on a determination whether benefits shall be granted.

**AUTHORITY NOTE:** Promulgated in accordance with R.S. 23:1471-1713.

**HISTORICAL NOTE:** Promulgated by the Workforce Commission, Office of Unemployment Insurance, LR 39:2314 (August 2013).

### §325. Definitions of Week

#### A. The term:

1. *week*—a *calendar week*;
2. *calendar week*—the seven consecutive days commencing at 12:01 a.m. on Sunday and ending at midnight on Saturday.

#### B. Week of Total or Part-Total Unemployment

1. A *week of total or part-total unemployment*—the seven-consecutive-day period commencing with the first day of the calendar week in which occurs the day, subsequent to his separating from work, on which an individual registers and files a claim to the Louisiana Workforce Commission, except as otherwise provided in §325.B.2 and 3.

2. A week of total or part-total unemployment for an individual who fails for good cause to register and file a

claim for benefits as specified in §325.B.1-3 shall consist of the calendar week in which the individual becomes unemployed, provided that such individual registers with the Louisiana Workforce Commission within a period of seven days after such first day of total or part-total unemployment, or on the next day thereafter on which the itinerant service is available, or by mail within 14 days after the commencement of such unemployment; and thereafter each calendar week immediately following such week, provided the individual claims benefits for each such week in accordance with regulations.

3. A *week of total or part-total unemployment* of any individual affected by a mass separation or labor dispute shall consist of the calendar week in which the individual becomes unemployed, provided that notice thereof is filed by the individual with the administrator within 14 days next following such first day of unemployment; and thereafter each calendar week immediately following such week, provided the individual claims benefits for any such week in accordance with regulations.

#### C. Week of Partial Unemployment

1. With respect to a partially unemployed individual as defined by §327.B.1 whose wages are paid on a weekly basis, a week of partial unemployment shall consist of a calendar week, provided that the administrator may, upon his own initiative or upon application, prescribe as to any individual or group of individuals such other seven-consecutive-day period as he may find appropriate under the circumstances.

2. For the purpose of this regulation, an individual shall be deemed to be partially unemployed during not more than four consecutive weeks of total unemployment if such weeks immediately follow a week of partial unemployment and if in such weeks there is a reasonable expectation of his return to employment with such employer.

**AUTHORITY NOTE:** Promulgated in accordance with R.S. 23:1471-1713.

**HISTORICAL NOTE:** Promulgated by the Department of Labor, Office of Employment Security, LR 15:489 (June 1989), amended by the Department of Employment and Training, Office of Employment Security, LR 17:41 (January 1991), amended by the Workforce Commission, Office of Unemployment Insurance, LR 39:1835 (July 2013).

### §327. Types of Unemployment

A. **Total Unemployment.** A totally unemployed individual is one who, during any week, performs no services and in which no wages are payable to him.

#### B. Partial Unemployment

1. A partially unemployed individual is one who, during a particular week, earned less than his weekly benefit amount, was employed by a regular employer, and worked less than his normal customary full-time hours for such regular employer because of lack of full-time work.

2. A regular employer is an employer by whom the individual is employed on a regular basis with a reasonable expectation of continuance in that employment and from

whom the individual derives the predominant or substantial part of his earnings.

C. Part-Total Unemployment. A part-total unemployed individual is one who, during any week, earned less than his weekly benefit amount and worked less than his full-time hours under any circumstances other than those prescribed under §327.B.

AUTHORITY NOTE: Promulgated in accordance with R.S. 23:1471-1713.

HISTORICAL NOTE: Promulgated by the Department of Labor, Office of Employment Security, LR 15:490 (June 1989), amended by the Department of Employment and Training, Office of Employment Security, LR 17:41 (January 1991).

### **§329. Registration for Work and Claims for Benefits for Total and Part-Total Unemployment**

A. Claims for benefits for total or part-total unemployment shall be made on forms prescribed by the administrator for that purpose. In order to claim benefits or waiting period credits for unemployment, an individual shall:

1. file a claim for benefits.

B. The continued claim for benefits for total or part-total unemployment shall be made on forms prescribed by the administrator. Except as otherwise provided in this Section and §333, to establish eligibility for benefits or waiting credits for weeks of total or part-total unemployment during any continuous period of unemployment, the claimant shall continue to report weekly or biweekly, or at more frequent intervals, if directed by the administrator or his representative, to the Louisiana Workforce Commission, provided the reporting at more frequent intervals places no unreasonable burden on him or does not unreasonably limit his opportunity to establish his rights to benefits. For reasons found to be cause for any individual's failure to report, a continued claim may be accepted from such individual, effective as of the first day of his week of total or part-total unemployment, if such continued claim is filed within seven days following the date specified for his reporting. If the failure of an individual to file such a claim at the time specified is found to be without good cause or if the continued claim is not filed within the above mentioned seven days, the continued claim will be disallowed.

C. An individual who returns to employment under conditions which no longer render him eligible for benefits or waiting period credits may claim benefits in person or by mail for the week or portion of a week immediately preceding his employment, provided the week or portion of a week follows without interruption an initial claim or a week for which benefits or waiting period credits were claimed.

D. The administrator may waive or alter either or both of the requirements of this Section to an individual who:

1. is a paid up union member of a recognized craft union;

2. is partially employed and files a claim for part-total benefits;

3. files a claim for shared-work benefits under a shared-work plan; or

4. is on temporary layoff from his regular work with a definite date of return and holds himself available for reemployment at his last place of work.

AUTHORITY NOTE: Promulgated in accordance with R.S. 23:1471-1713.

HISTORICAL NOTE: Promulgated by the Department of Labor, Office of Employment Security, LR 15:490 (June 1989), amended by the Department of Employment and Training, Office of Employment Security, LR 17:41 (January 1991), amended by the Workforce Commission, Office of Unemployment Insurance, LR 39:1835 (July 2013).

### **§331. Registration for Work and Claims for Benefits for Partial Unemployment**

A. Employer Responsibility in the Initiation of a First Claim for Partial Benefits in a Benefit Year

1. Immediately after the termination of any calendar week in which a worker earned less than 60 percent of his customary full-time weekly wage due to lack of work, his employer shall give such worker a low earnings report form, application for partial benefits, setting forth therein the information required of the employer. If such worker completes and returns the low earnings report form to his employer, such employer shall promptly mail or otherwise transmit such form to the Louisiana Workforce Commission.

2. Upon receipt of the low earning report form, the Louisiana Workforce Commission shall promptly notify such worker named therein of his potential rights to partial benefits and shall notify his employer of such worker's weekly benefit amount and benefit year ending date. Upon receipt thereof, such employer shall record such weekly benefit amount and benefit year ending date upon his payroll records.

B. Employer to Furnish Evidence of Subsequent Weeks of Partial Unemployment. After an employer has been notified of the weekly benefit amount and current benefit year ending date of any worker in his employ, such employer, until otherwise notified, shall immediately after the termination of each calendar week which begins within such benefit year and for which such worker's earnings fall below such weekly benefit amount because of lack of work in such week, furnish each such worker with a copy of the low earnings report form, application for partial benefits, setting forth the information required therein, including the worker's name and Social Security account number, the ending date of such week, the wages earned therein, and a proper certification as to his having worked less than his normal customary full-time hours because of lack of work in such week. If such worker completes and returns such form to his employer, such employer shall promptly mail or otherwise transmit such form to the Louisiana Workforce Commission.

C. Registration and Filing of Claims for Partial Unemployment. A claim for benefits for any individual on the low earnings report form, application for partial benefits, or other form designated by the Louisiana Workforce Commission, mailed by him or his employer in his behalf, or delivered to the Louisiana Workforce Commission shall constitute such individual's notice of unemployment, registration for work, and claim for benefits or waiting period credit, with respect to each such week of partial unemployment covered by the claim provided that such form is executed by such individual and received by the Louisiana Workforce Commission through which the employer has a partial claims agreement within seven days following the week to which the form pertains.

D. Extended Period for Registration and Filing of Claims for Good Cause. Notwithstanding the provisions of §331.C, if the administrator finds that the failure of any individual to register and file a claim for partial unemployment benefits within the time set forth in §331.C was due to failure on the part of the employer to comply with any of the provisions of §331.A, B, and C, or to coercion or intimidation exercised by the employer to prevent the prompt filing of such claim, or to failure by the Louisiana Workforce Commission to discharge its responsibilities promptly in connection with such partial unemployment, the administrator shall extend the period during which such claim may be filed to a date which shall be not less than one week after the individual has received appropriate notice of his potential rights to benefits and his earnings during the period of such partial unemployment, provided that the period during which such claim may be filed shall not be extended beyond the 13-week period subsequent to the end of the actual or potential benefit year during which such week of partial unemployment occurred.

E. Employer Records in Connection with Partial Unemployment. In addition to the requirements set forth in §313, each employer shall keep his payroll records in such form that it would be possible for an inspection to determine with respect to each worker in his employ who may be eligible for partial benefits:

- 1.a. wages earned, by weeks, described in §327.B;
  - b whether any week was in fact a week of less than full-time work; and
  - c. time lost, if any, for each such worker, due to his unavailability for work;
2. this regulation applies only to employers with a partial employer agreement with one or more of the Louisiana Workforce Commission.

AUTHORITY NOTE: Promulgated in accordance with R.S. 23:1471-1713.

HISTORICAL NOTE: Promulgated by the Department of Labor, Office of Employment Security, LR 15:491 (June 1989), amended by the Department of Employment and Training, Office of Employment Security, LR 17:42 (January 1991), amended by the Workforce Commission, Office of Unemployment Insurance, LR 39:1836 (July 2013).

### §335. Witness Fees in Appeal Hearing

A. A witness attending an appeal hearing in obedience to R.S. 23:1631 shall be reimbursed his necessary traveling expenses in conformity with agency travel regulations. The regulation shall not be construed as allowing witness fees or mileage to any party interested in the appeal.

AUTHORITY NOTE: Promulgated in accordance with R.S. 23:1471-1713.

HISTORICAL NOTE: Promulgated by the Department of Labor, Office of Employment Security, LR 15:492 (June 1989), amended by the Department of Employment and Training, Office of Employment Security, LR 17:43 (January 1991).

### §337. Payment of Benefits and Change of Address

A. Benefit payments shall be made to the claimant by electronic funds transfer to his bank account, by debit card, check, or other electronic means. Supplemental payments may, in the discretion of the administrator, be made by check, automatic clearing house (ACH), or electronic funds transfer after determination of the individual's eligibility for payment.

B. Each claimant, upon changing his address, shall immediately notify the Louisiana Workforce Commission of such change.

AUTHORITY NOTE: Promulgated in accordance with R.S. 23:1471-1713.

HISTORICAL NOTE: Promulgated by the Department of Labor, Office of Employment Security, LR 15:492 (June 1989), amended by the Department of Employment and Training, Office of Employment Security, LR 17:43 (January 1991), amended by the Workforce Commission, Office of Unemployment Insurance, LR 39:1837 (July 2013).

### §339. Interstate Claims

A. Interstate claims will be administered under arrangements entered into by the administrator with the appropriate agencies of other states or of the United States in accordance with R.S. 23:1666 of the Louisiana Employment Security Law.

AUTHORITY NOTE: Promulgated in accordance with R.S. 23:1471-1713.

HISTORICAL NOTE: Promulgated by the Department of Labor, Office of Employment Security, LR 15:492 (June 1989), amended by the Department of Employment and Training, Office of Employment Security, LR 17:43 (January 1991).

### §341. Regulations for Interstate Charging

A. Louisiana employers shall be charged or noncharged in cases where Louisiana transfers wages earned with Louisiana employers to another state in order that that state pay unemployment compensation benefits.

B. The Louisiana employer will be notified of their potential liability and be given 10 days to protest chargeability. Louisiana will determine if the employer should or should not be charged in accordance with §1553 of the Louisiana Employment Security Law based on information supplied by both claimant and employer. Louisiana will not determine claimant eligibility as this is done by the paying state under their Unemployment

Compensation Law. If either claimant or employer disagree with the determination, appeal rights will be given in accordance with Employment Security Law.

C. If the employer fails to respond within the first 10 days or fails to follow through timely with any subsequent appeal, the last decision of the agency will stand, and the employer will have lost all subsequent appeal rights.

D. If it is determined that the employer is to be "noncharged," the benefits paid to claimant will be recouped in accordance with §1553 of the Louisiana Employment Security Law.

AUTHORITY NOTE: Promulgated in accordance with R.S. 23:1471-1713.

HISTORICAL NOTE: Promulgated by the Department of Labor, Office of Employment Security, LR 15:492 (June 1989), amended by the Department of Employment and Training, Office of Employment Security, LR 17:43 (January 1991).

### §343. Employer Elections to Cover Multi-State Workers

A. The following regulations, adopted under R.S. 23:1665 of the Louisiana Employment Security Law, shall govern Louisiana Workforce Commission in its administrative cooperation with other states subscribing to the interstate reciprocal coverage arrangement, herein referred to as *the arrangement*.

B. Definitions, as used in this regulation, unless the context clearly indicates otherwise.

*Agency*—any officer, board, commission or other authority charged with the administration of the unemployment compensation law of the participating jurisdiction.

*Interested Jurisdiction*—any participating jurisdiction to which an election submitted under this regulation is sent for its approval; and

a. *interested agency*—the agency of such jurisdiction.

*Jurisdiction*—any state of the United States, the District of Columbia, Canada, or with respect to the federal government, the coverage of any federal unemployment compensation law.

*Participating Jurisdiction*—a jurisdiction whose administrative agency has subscribed to the arrangement and whose adherence thereto has not terminated.

*Service Customarily Performed by an Individual in More than One Jurisdiction*—services performed in more than one jurisdiction during a reasonable period, if the nature of the services gives reasonable assurance that they will continue to be performed in more than one jurisdiction or if such services are required or expected to be performed in more than one jurisdiction under the election.

C. Submission and Approval of Coverage Elections under the Interstate Reciprocal Coverage Arrangement

1. Any employing unit may file an election, on Form RC-1, to cover under the law of a single participating jurisdiction all of the services performed for him by any individual who customarily works for him in more than one participating jurisdiction.

2. Such an election may be filed, with respect to an individual, with any participating jurisdiction in which:

a. any part of the individual's services are performed;

b. the individual has his residence; or

c. the employing unit maintains a place of business to which individual's services bear a reasonable election.

3. The agency of the elected jurisdiction (thus selected and determined) shall initially approve or disapprove the election.

4. If such agency approves the election, it shall forward a copy thereof to the agency of each participating jurisdiction specified thereon, under whose unemployment compensation law the individual or individuals in question might, in the absence of such election, be covered. Each such interested agency shall approve or disapprove the election as promptly as practicable and shall notify the agency of the elected jurisdiction accordingly.

5. In case its law so requires, any such interested agency may, before taking such action, require from the electing employing unit satisfactory evidence that the affected employees have been notified of, and have acquiesced in, the election.

6. If the agency of the elected jurisdiction, or the agency of any interested jurisdiction, disapproves the election, the disapproving agency shall notify the elected jurisdiction and the elected employing unit of its action and of its reasons therefor.

7. Such an election shall take effect as to the elected jurisdiction only if approved by its agency and by one or more interested agencies.

8. An election thus approved shall take effect, as to the interested agency, only if it is approved by such agency.

9. In case any such election is approved only in part, or is disapproved by some of such agencies, the electing employing unit may withdraw its election within 10 days after being notified of such action.

#### D. Effective Period of Elections

##### 1. Commencement

a. An election duly approved under this regulation shall become effective at the beginning of the calendar quarter in which the election was submitted, unless the election, as approved, specifies the beginning of a different calendar quarter.

b. If the electing unit requests an earlier effective date than the beginning of the calendar quarter in which the election is submitted, such earlier date may be approved



solely as to those interested jurisdictions in which the employer has no liability to pay contributions for the earlier period in question.

## 2. Termination

a. The application of an election to any individual under this regulation shall terminate, if the agency of the elected jurisdiction finds that the nature of the services customarily performed by the individual for the electing unit has changed, so that they are no longer customarily performed in more than one participating jurisdiction. Such termination shall be effective as of the close of the calendar quarter in which notice of such finding is mailed to all parties affected.

b. Except as provided in §343.D.2.a, each election approved hereunder shall remain in effect through the close of the calendar year in which it is submitted, and thereafter until the close of the calendar quarter in which the electing unit gives written notice of its termination to all affected agencies.

c. Whenever an election under this regulation ceases to apply to any individual under §343.D.2.a or b, the electing unit shall notify the affected individual accordingly.

### E. Reports and Notices by the Electing Unit

1. The electing unit shall promptly notify each individual affected by its approved election, on the Form RC-2 supplied by the elected jurisdiction, and shall furnish the elected agency a copy of such notice.

2. Whenever an individual covered by an election under this regulation is separated from his employment, the electing unit shall again notify him, forthwith, as to the jurisdiction under whose unemployment compensation law his services have been covered. If at the time of termination the individual is not located in the election jurisdiction, the electing unit shall notify him as to the procedure for filing interstate benefit claims.

3. The electing unit shall immediately report to the elected jurisdiction any change which occurs in the conditions of employment pertinent to its election, such as cases where an individual's services for the employer cease to be customarily performed in more than one participating jurisdiction or where a change in the work assigned to an individual requires him to perform services in a new participating jurisdiction.

F. Approval of Reciprocal Coverage Elections. The Louisiana Workforce Commission hereby delegates to its administrator authority to approve or disapprove reciprocal coverage election in accordance with this regulation.

G. Contributions paid in another state shall not be credited to those contributions which are otherwise due and payable in the state of Louisiana.

AUTHORITY NOTE: Promulgated in accordance with R.S. 23:1471-1713.

HISTORICAL NOTE: Promulgated by the Department of Labor, Office of Employment Security, LR 15:492 (June 1989), amended by the Department of Employment and Training, Office

of Employment Security, LR 17:43 (January 1991), amended by the Workforce Commission, Office of Unemployment Insurance, LR 39:1837 (July 2013).

## §345. Recognition of Heirs of Deceased Benefit Claimants

A. The heirs of a deceased benefit claimant may make application by submitting a formal affidavit of heirship, to have paid to them all moneys due the deceased at the time of his death. Affidavits must be submitted by all heirs of full age and majority, or if there be minor heirs, the affidavit must be submitted by their authorized representative.

AUTHORITY NOTE: Promulgated in accordance with R.S. 23:1471-1713.

HISTORICAL NOTE: Promulgated by the Department of Labor, Office of Employment Security, LR 15:493 (June 1989), amended by the Department of Employment and Training, Office of Employment Security, LR 17:43 (January 1991).

## §347. Transfer of Experience-Rating Record to Successor Where Segregable and Identifiable Part or Portion of the Business Is Acquired

A. The transfer of experience-rating records to employers who acquired a segregable and identifiable portion of a predecessor's business within the meaning of R.S. 23:1539 shall be affected on the following basis.

1. Where the business or unit acquired can be completely segregated and identified during the entire period of its existence, the total payroll and experience-rating record attributable thereto shall be transferred to the successor. In this event the only payroll and experience rating records subject to transfer to the successor are those which are actually segregated and identified.

2.a. If the business or unit acquired cannot be segregated and identified during the entire period of its existence, the predecessor and/or the partial successor will provide to the administrator the percentage of the operation that was transferred to the partial successor. The percentage must be agreed upon by both the predecessor and the partial successor. This percentage may be determined by dividing the taxable payroll attributed to the portion acquired for three complete fiscal years prior to the acquisition or the number of years the predecessor was in operation prior to acquisition up to three years, by the total payroll attributed to the predecessor operation for the same period of time.

b. The percentage will be applied to the predecessor's total taxable payroll and reserve to determine the taxable payroll and reserve that will be transferred to the partial successor.

c. The names and Social Security numbers of the individuals transferred to the successor, including any employees terminated at the time of the acquisition, must be provided to the administrator and agreed upon by both the predecessor and partial successor.

d. If any of the above agreements are not received in writing within 90 days from the date of the partial acquisition, the requirements for partial transfer of payroll

records to the partial successor have not been met, and none will be transferred.

3. Determining the Tax Rates for Partial Successors When the Information Is Received on a Timely Basis, within 90 Days from the Date of Acquisition. If the successor was not an employer at the time of acquisition, his rate for the balance of the then current contribution year shall be the same as that assigned to his predecessor for said year. If the successor was an employer prior to the date of acquisition, his rate of contribution for the period from such date to the end of the then current contribution year shall be the same as his rate with respect to the period immediately preceding the date of acquisition.

4. Determining the Tax Rates for Partial Successors When the Information Has Not Been Provided on a Timely Basis within 90 Days from Date of Acquisition

a. If the partial successor was not a subject employer at the time of acquisition, his rate for the balance of the then current contribution year shall be the new employer rate or the predecessor rate, whichever is higher.

b. If the partial successor was an employer prior to date of acquisition, his rate of contribution for the period from such date to the end of the then current contribution year shall be the same as his rate with respect to the period immediately preceding the date of acquisition.

5. If an employer has more than one partial succession in a calendar year, the aforementioned procedure will be applied in each case.

6. Partial successors who have not been assigned a tax rate prior to acquisition will be assigned the new employer tax rate or the predecessor's tax rate, whichever is higher, during the 90-day period subsequent to the partial acquisition. Once the proper tax rate is determined, however, it will be applied retroactively.

7. The agency may perform an audit to determine the percentage of taxable payroll and reserve that will be transferred to the partial successor if the administrator finds it necessary to do so.

8. In determining whether or not the unit, or portion of the business acquired by the successor, is segregable and identifiable, each case should be separately considered and analyzed. If the payroll and experience-rating records of the unit, or portion of the business acquired, can be broken down and segregated to permit the proper crediting of wages, contribution of payments and the charging of benefits, as provided in this regulation, the requirements of the law shall be considered as having been fully met. The employer will be required to furnish such additional analysis of his payroll records as may be required in order that proper segregation may be made.

**AUTHORITY NOTE:** Promulgated in accordance with R.S. 23:1471-1713.

**HISTORICAL NOTE:** Promulgated by the Department of Labor, Office of Employment Security, LR 15:493 (June 1989), amended by the Department of Employment and Training, Office of Employment Security, LR 17:45 (January 1991).

### **§349. Contribution and Wage Reports Covering Seamen and Seamen's Wages Paid under Shipping Articles**

A. Pay Period. For the purpose of this regulation the term "pay period" established by "Shipping Articles" means the period of the voyage or engagement of the crew under "Articles of Agreement" pursuant to Title 46 of the United States Code.

B. Current Reports. Notwithstanding any other provision of other regulations, contribution reports and wage reports with respect to wages earned in any pay period established by Shipping Articles shall be submitted as follows.

1. The total amount of such wages shall be included in the wage report and contribution report for the calendar quarter in which such period terminates together with all other wages paid during such quarter.

2. If the pay period established under shipping articles includes more than one calendar quarter, the beginning dates of such pay period shall be shown opposite the amount of wages reported.

3. For the purpose of obtaining eligibility for and the amount of benefits, the wages so reported shall be prorated among the calendar quarters in which the wages were earned according to the length of employment in each of such quarters.

C. Special Reports. The employer shall, upon request of the administrator, promptly furnish a statement of the wages of a seaman, whenever such statement is necessary in order to determine such seaman's eligibility for and rate of benefits. If such a statement includes wages which have not previously been included in a wage report and have been earned in a pay period extending over more than one calendar quarter, such wages shall be reported and prorated as set forth in §349.B.2 and 3.

**AUTHORITY NOTE:** Promulgated in accordance with R.S. 23:1471-1713.

**HISTORICAL NOTE:** Promulgated by the Department of Labor, Office of Employment Security, LR 15:494 (June 1989), amended by the Department of Employment and Training, Office of Employment Security, LR 17:45 (January 1991).

### **§351. Benefit Determination Notice**

A. Each notice of benefit determination which the administrator is required to furnish the claimant shall, in addition to stating the decision and its reason, include a notice specifying the claimant's appeal rights. The notice of appeal rights shall state clearly the place and manner for taking an appeal from the determination and the period within which an appeal may be taken.

**AUTHORITY NOTE:** Promulgated in accordance with R.S. 23:1471-1713.

**HISTORICAL NOTE:** Promulgated by the Department of Labor, Office of Employment Security, LR 15:494 (June 1989), amended by the Department of Employment and Training, Office of Employment Security, LR 17:46 (January 1991).

**§353. Disclosure of Information Pursuant to R.S. 23:905**

A. R.S. 23:905 governs the agency's sharing Louisiana workers' employer and wage information (hereinafter *shared information*) with third-party vendors that facilitate the obtaining of such information by third parties under circumstances where such sharing is permitted by 20 CFR part 603 and not otherwise prohibited by law. A third-party vendor is a person or entity that facilitates the obtaining of shared information as an authorized agent of another person or entity to whom the release of the shared information is permitted by law and by 20 CFR part 603. However, this rule shall not apply to or restrict the sharing of such information, to the extent permitted by law and 20 CFR part 603, directly to the individual or the individual's attorney.

B. All sharing of data pursuant to R.S. 23:905 shall comply with 20 CFR part 603 and any other federal requirements or formal guidance governing such data sharing, including but not by way of limitation the requirement that the terms and conditions of such data sharing arrangements be prescribed in a data-sharing agreement. The agency shall require third party vendors to sign agreements with the agency establishing specific terms and conditions determined by the agency, in its sole discretion, to be necessary and appropriate to the particular data sharing arrangement with the third-party vendor.

C. Before providing any shared information to a third-party vendor, the agency shall require from the third-party vendor and/or the person or entity on whose behalf the third-party vendor requests shared information (the client) documentation sufficient to verify the third-party vendor's representation of the client. The agency's costs in establishing any such data sharing arrangement shall be paid to the agency as a condition precedent to the implementation of any information sharing arrangement under R.S. 23:905.

D. A release consenting to the disclosure that meets the requirements of 20 CFR Part 603 and signed by each person whose information is requested shall be provided to the agency before any data about that person is shared pursuant to this rule, and the agency's cost in providing said information shall be paid to the agency before the requested information is provided to the third-party vendor. The agency may accept a release that is effectuated electronically to the extent permitted by United States Department of Labor unemployment insurance program letter No. 19-12, or any other subsequent official guidance or requirements promulgated by the United States Department of Labor.

E. Third-party vendors shall reimburse the agency for all costs the agency incurs in defending or resisting subpoenas or other legal demands made upon the third-party vendor or their customers seeking the release of information shared pursuant to R.S. 23:905.

F. The purposes for which shared information may be provided to third-party vendors are limited to lending purposes, tenant screening and insurance underwriting, and such sharing is permitted only if the purpose specified in the release provides a service or benefit the individual expects to

receive as a result of signing the release. The use of shared information for marketing or any other purposes is prohibited.

G. As required by 20 CFR Part 603, the agency must conduct, and third-party vendors and their clients must permit, random on-site visits by agency auditors of their compliance with the requirements governing their access to, redisclosure of, and retention and disposal of shared information.

AUTHORITY NOTE: Promulgated in accordance with R.S. 23:1471-1713.

HISTORICAL NOTE: Promulgated by the Department of Labor, Office of Employment Security, LR 15:494 (June 1989), amended by the Department of Employment and Training, Office of Employment Security, LR 17:46 (January 1991), amended by the Workforce Commission, Office of Unemployment Insurance, LR 39:2314 (August 2013).

**§355. Services to Claimants**

A. Claims personnel will give each claimant such assistance as is appropriate and practicable in finding suitable work and at their discretion determine when more complete placement and employment services by employment service personnel are necessary and appropriate.

AUTHORITY NOTE: Promulgated in accordance with R.S. 23:1471-1713.

HISTORICAL NOTE: Promulgated by the Department of Labor, Office of Employment Security, LR 15:495 (June 1989), amended by the Department of Employment and Training, Office of Employment Security, LR 17:46 (January 1991).

**§357. Terms and Conditions Not Applicable to Claims for Payment of Extended Compensation**

A. Section 1600(4) of the Louisiana Employment Security Law, pertaining to a waiting period of one week, is not applicable to claims for extended compensation.

B. All disqualifications for regular benefits apply to extended benefits in the same manner and to the same extent as to regular claims.

C. The forwarding of an extended compensation claim notice to a former employer of an individual does not serve to reopen a previously resolved issue or open to adjudication any issue concerning which an employer failed to furnish information within the time provided by §323 and §324.

AUTHORITY NOTE: Promulgated in accordance with R.S. 23:1471-1713.

HISTORICAL NOTE: Promulgated by the Department of Labor, Office of Employment Security, LR 15:495 (June 1989), amended by the Department of Employment and Training, Office of Employment Security, LR 17:46 (January 1991), amended by the Workforce Commission, Office of Unemployment Insurance, LR 39:2315 (August 2013).

**§359. Approved Training Definition**

*Approved Training*—training to which an individual has been referred by the administrator of the Louisiana Workforce Commission or his duly authorized representative.

1. Referral to training will be made to vocational training, basic education or other short term vocationally directed academic courses designed to develop a particular skill.

2. Approval of training in such types of courses may also be given, upon application, if the individual has been accepted as a student at a school or course approved by the Louisiana Department of Education, which is designed to make the individual employable or more employable in an occupation that is in demand and there is reasonable expectation that the individual will be employed upon completion, except no approval will be given to any training course taken primarily for credit toward the degree requirements of baccalaureate or advanced degree, and no approval will be given to a training course which will take longer than 104 weeks to complete

3. No training will be approved for an individual unless it is found that the demands for his present skills are minimal and not likely to improve under present circumstances.

a. The individual in training will be required to furnish reports from the training facility concerning his attendance. Unsatisfactory attendance attested to by the training facility shall constitute grounds for terminating application of the provisions of R.S. 23:1602(1) to the individual unless good cause is shown for the unsatisfactory attendance.

AUTHORITY NOTE: Promulgated in accordance with R.S. 23:1471-1713.

HISTORICAL NOTE: Promulgated by the Department of Labor, Office of Employment Security, LR 15:495 (June 1989), amended by the Department of Employment and Training, Office of Employment Security, LR 17:47 (January 1991), amended by the Workforce Commission, Office of Unemployment Insurance, LR 39:1838 (July 2013).

### §361. Types of Employment

A. For purposes of R.S. 23:1601(1):

*Full-Time Employment*—employment which requires the individual's presence for the major portion of the normal work-day, week, or month. Full-time employment is that employment which normally provides an individual with the major portion of his earnings.

*Interim Employment*—employment performed by individuals who are on temporary layoff or are otherwise separated from their full-time regular employment and expect to return to their full-time regular employment within a reasonable time.

*Part-Time Employment*—employment which requires an individual's presence less than the normal workday, week, or month and is normally used to supplement income from full-time work.

*Regular Employment*—employment of an individual on a regular basis with a reasonable expectation of continuance in that employment.

AUTHORITY NOTE: Promulgated in accordance with R.S. 23:1471-1713.

HISTORICAL NOTE: Promulgated by the Department of Labor, Office of Employment Security, LR 15:495 (June 1989), amended by the Department of Employment and Training, Office of Employment Security, LR 17:47 (January 1991).

### §363. Proof of Unemployment by a Principal Officer or Controlling Stockholder, or Relative thereof, of a Corporation, Partnership or Proprietorship

A. For the purpose of R.S. 23:1472(19) an individual who was the principal officer or controlling stockholder of a corporation, partnership or proprietorship or related to him in any degree as set forth in Paragraph (a) thereof, shall be deemed to be "unemployed" if:

1. the corporation, partnership or proprietorship does not appear as an employer in the individual's base period; and

2. he otherwise meets the definition of "unemployed."

B. If the corporation, partnership or proprietorship does not appear in the individual's base period as an employer, he shall be deemed to be unemployed if:

1. the employing unit is no longer in business or acts beyond the control of the controlling stockholder or principal officer occurred to such an extent to fully justify the individual's inability to perform services judged on the same basis as any employer under similar conditions; and

2. the individual otherwise meets the definition of "unemployed."

C. *Principal Officer*—the president, vice president, secretary or treasurer so designated by the corporation.

AUTHORITY NOTE: Promulgated in accordance with R.S. 23:1471-1713.

HISTORICAL NOTE: Promulgated by the Department of Labor, Office of Employment Security, LR 15:495 (June 1989), amended by the Department of Employment and Training, Office of Employment Security, LR 17:47 (January 1991).

### §364. Reciprocal Offset

A. An appeal of a determination to offset unemployment benefits under R.S. 23:1665.2 shall be limited to the authority of the administrator of the Louisiana Workforce Commission to offset against benefits payable to the claimant and shall be conducted in accordance with R.S. 23:1629 and R.S. 23:1630. All issues concerning the validity of the overpayment shall be directed by the claimant to the requesting state.

AUTHORITY NOTE: Promulgated in accordance with R.S. 23:1653 et seq.

HISTORICAL NOTE: Promulgated by the Workforce Commission, Office of Unemployment Insurance Administration, LR 40:374 (February 2014).

### §367. Assignment of Rates for Corporate Groups

A. If the administrator grants an employer the right to be recognized as a corporate group, the rate will be assigned as follows.

B. A new number will be assigned to the parent corporation. The rate for the then current year will be based on the combined experience rating records of all employers that form the corporate group.

AUTHORITY NOTE: Promulgated in accordance with R.S. 23:1471-1713.

HISTORICAL NOTE: Promulgated by the Department of Labor, Office of Employment Security, LR 15:496 (June 1989), amended by the Department of Employment and Training, Office of Employment Security, LR 17:47 (January 1991).

**§368. Disqualification for Benefits Pursuant to R.S. 23:1601(8)(a)**

A. The agency will notify the claimant by mail or other delivery method if the administrator has received information that the claimant has earned unreported wages for the weeks claimed.

1. The claimant shall have seven days from the date of the mailing to respond.

a. The claimant must provide adequate supporting documentation to establish that the unreported wages are incorrect.

b. Adequate documentation may include but is not limited to:

- i. proof of incorrect identity;
- ii. proof of incorrect date of wages;
- iii. check stubs;
- iv. time sheets;
- v. notice of separation or termination.

2. If the claimant requests notice to be sent by electronic delivery or delivery in another method beside mail, then the claimant shall have seven days from the delivery date of such notice to respond.

3. Acceptable forms of electronic delivery may include but are not limited to:

- a. facsimile;
- b. e-mail.

AUTHORITY NOTE: Promulgated in accordance with R.S. 23:1471-1713.

HISTORICAL NOTE: Promulgated by the Workforce Commission, Office of Unemployment Insurance, LR 39:2315 (August 2013).

**§369. Waiver of Overpayment Recovery**

A. Requirements for Waiver of Recovery of Overpayments

1. A waiver of the overpayment may be granted only if:

- a. the claimant was without fault in causing the overpayment;
- b. repayment would be against equity and good conscience; and

c. the claimant provided supporting documentation of his inability to pay in full or according to the repayment table in §371.

2. When a claimant appeals an overpayment determination, a written questionnaire shall be provided to claimant for an answer. The claimant shall return the completed questionnaire to the administrator within 15 days of the date of such questionnaire. If the claimant fails to return the completed questionnaire timely, then the waiver shall be denied.

3. In any proceedings, under this rule, the overpaid claimant shall have the burden of proving entitlement to a waiver.

**B. Determination of Fault**

1. To determine if fault existed on the part of the claimant, the factors considered shall include:

- a. gave inaccurate information;
- b. failed to disclose a material fact;
- c. knew or should have known that he/she is not entitled to the benefits;
- d. caused the overpayment by an act of omission of information known to the claimant; or
- e. had a determination of ineligibility due to fraud.

2. An affirmative finding on any one of the above precludes waiver of the overpayment.

**C. Equity and Good Conscience Determination**

1. In determining whether recovery of the overpayment would be against equity and good conscience, the factors considered shall include:

- a. financial and other information provided in response to the agency's request, which shall include information about:
  - i. all financial resources available to the claimant and members of the claimant's household;
  - ii. the claimant's living expenses, including, but not by way of limitation, expenses for:
    - (a). food;
    - (b). clothing;
    - (c). rent;
    - (d). debt payment;
    - (e). obligations;
    - (f). accident and health insurance;
    - (g). medical care;
    - (h). taxes;
    - (i). work related transportation; and
    - (j). the support of others for whom the claimant is legally responsible; and

LABOR AND EMPLOYMENT

iii. any other factors that impact the claimant's ability to cover ordinary living expenses for at least six months;

2. whether the claimant was given notice that a reversal on appeal would result in an overpayment.

D. All notices of determination of overpayment shall include information regarding rights of appeal and waiver provisions.

AUTHORITY NOTE: Promulgated in accordance with R.S. 23:1471-1713.

HISTORICAL NOTE: Promulgated by the Department of Labor, Office of Employment Security, LR 15:1086 (December 1989), repromulgated LR 17:48 (January 1991), amended by the Workforce Commission, Office of Unemployment Insurance, LR 39:2315 (August 2013).

**§371. Overpayment Recovery**

A. This Rule prescribes an acceptable repayment schedule for the purpose of collecting overpaid benefits pursuant to R.S. 23:1713.

1. The amount of overpayment is immediately due and payable on demand upon exhaustion of the right to appeal:

- a. a determination of overpayment; and/or
- b. a denial of waiver of overpayment.

2. If an individual is unable to immediately repay the overpayment in full upon demand, a repayment agreement in writing will be negotiated in compliance with the repayment table for overpayments listed below.

Repayment Tables Total for Overpayments			
Total Overpayment Amount is: At Least	But Less Than:	Number of Months to Repay	Minimum Monthly Payment
\$1	\$500	12	\$42
\$501	\$1,000	12	\$84
\$1,001	\$1,500	18	\$84
\$1,501	\$2,000	18	\$112
\$2,001	\$2,500	24	\$105
\$2,501	\$3,000	24	\$125
\$3,001	\$3,500	30	\$117
\$3,501	\$4,000	30	\$134
\$4,001	\$4,500	36	\$125
\$4,501	\$5,000	36	\$139
\$5,001	\$5,500	42	\$131
\$5,501	\$6,000	42	\$143
\$6,001	\$6,500	48	\$136
\$6,501	\$7,000	48	\$146
\$7,001	\$7,500	54	\$139
\$7,501	\$8,000	54	\$149
\$8,001	\$8,500	60	\$142
\$8,501	\$9,000 or greater	60	\$150

B. The initial payment and signed repayment agreement must be received within 30 days from the day that the repayment agreement is mailed to the individual's last known address. Subsequent payments are to be paid in monthly installments which commence no later than 30 days after the initial payment is received, and are due thereafter each month until paid in full.

C. An adjustment of the repayment schedule may be granted at the written request of the claimant only if there has been material change in his or her financial condition.

D. Requests to adjust the repayment schedule will only be granted if warranted by the criteria set forth in §369.C, waiver of overpayment recovery, equity and good conscience determination.

AUTHORITY NOTE: Promulgated in accordance with R.S. 23:1471-1713.

HISTORICAL NOTE: Promulgated by the Department of Labor, Office of Employment Security, LR 15:1085 (December 1989), repromulgated LR 17:48 (January 1991), amended by the Workforce Commission, Office of Unemployment Insurance, LR 39:2316 (August 2013), amended by the Workforce Commission, Office of Unemployment Insurance Administration, LR 40:1118 (June 2014).

**§373. Medical Services Performed by Physician or Professional Corporation**

A. For the purpose of exclusion of medical services rendered by a physician or professional corporation on behalf of a hospital or other medical facility or institution under R.S. 23:1472(12)(H)(XIX), written certification from the Internal Revenue Service of exemption as an independent contractor or a non-profit organization shall be submitted to the administrator by such physician or professional corporation.

AUTHORITY NOTE: Promulgated in accordance with R.S. 23:1471-1713.

HISTORICAL NOTE: Promulgated by the Department of Employment and Training, Office of Employment Security, LR 17:48 (January 1991).

**§375. Determining Whether Workers are Employees or Independent Contractors**

A. The totality of the circumstances will be considered in determining whether workers are properly classified as employees or independent contractors, including the following factors regarding control and direction of each individual worker's position under R.S. 23:1472(12)(E)(I).

1. Behavioral Control. Facts that show a right to control or direct how the worker does the task for which the worker is hired. The type and degree of instruction given to the worker shall be considered including, but not limited to:

- a. when and where to do the work;
- b. what tools or equipment to use;
- c. what workers to hire or to assist with the work;
- d. where to purchase supplies and services;
- e. what work must be performed by a specified individual;
- f. what order or sequence to follow in performing the work;
- g. how work results are achieved;
- h. whether the worker is hired and discharged under specific terms of an agreement or at-will;

i. the extent to which the worker is subjected to pre-employment testing, credentialing, resume verification, background checks, drug testing and/or pre-employment physicals;

j. the extent to which the job opening was represented as employment; and

k. training given the worker.

2. Financial Control. Facts that show whether there is a right to control or direct the business aspects of the worker's job including, but not limited to:

a. the extent to which the worker has unreimbursed business expenses;

b. the extent of the worker's investment in the tasks beyond the worker's own time;

c. the extent to which the worker makes services available to the relevant market;

d. whether payment is made based solely upon time worked or includes other factors;

e. whether the worker tracks time worked and calculates amounts due; and

f. the extent to which the worker can realize a profit or loss.

3. Type of Relationship. Facts that show the nature of the parties' relationship including, but not limited to:

a. written contracts describing the relationship the parties intended to create;

b. whether the worker is provided employee-type benefits, such as insurance, a pension plan, vacation pay, or sick pay;

c. whether the relationship is of a definite term; and

d. the extent to which services performed by the worker are similar to duties of employees at the worksite.

4. A prior determination by a taxing authority regarding the relationship.

5. As used in R.S. 23:1472(12)(e), the term *any control or direction* shall include, but not by way of limitation, direction or control exercised at the worksite by any person authorized to direct or control the work performed.

AUTHORITY NOTE: Promulgated in accordance with R.S. 23:1653 et seq.

HISTORICAL NOTE: Promulgated by the Workforce Commission, Office of Unemployment Insurance Administration, LR 40:549 (March 2014).

**§377. Electronic Filing and Payment Requirements**

A. All employers must file quarterly, annual, and amended wage reports electronically for any reports due after January 31, 2014.

B. All employer's agents and professional employer organizations, as defined in R.S. 23:1761, must file

quarterly, annual, and amended wage reports electronically for any employer's reports due after January 31, 2014.

C. Contributions must be paid by the following methods:

1. electronic funds transfer (EFT);

2. automated clearing house (ACH); or

3. any other method of payment approved by the administrator.

D. Any requested Federal 940 and 941 forms, 1099 and 1096 forms, and W-2 and W-3 forms must be submitted in response to an audit in an electronic data format specified by the Workforce Commission and to the site indicated in correspondence from the Workforce Commission. All other forms must be transmitted electronically.

E. Employers, employer's agents, and professional employer organizations shall be required to respond to requests for information as part of a wage investigation. Correspondence from the Workforce Commission will indicate the site where electronic forms can be completed. Responses shall be made by logging into the site and filling out the electronic forms. Other forms of submission may be accepted at the discretion of the administrator.

F. The electronic reporting requirements under Subsection D may be waived by the administrator only upon a showing by the employer, employer's agent, or professional employer organization that electronic reporting creates a hardship. All applications for a waiver must be in writing and submitted to the administrator, setting forth detailed reasons the requirement to file electronically creates a hardship.

1. The term *hardship* includes, without limitation:

a. a financial burden or expense which significantly impairs the employer's ability to continue to conduct its business;

b. electronic filing requirements under Subsection D would impose a *hardship* due to a physical disability or geographic barrier;

c. the requirement under Subsection D to file electronically is contrary to equity or good conscience due to the specific circumstances of the employer requesting the waiver.

2. A request for a waiver from the electronic filing requirements under Subsection D must be delivered to the administrator prior to the due date for receipt of the reports that the employer is seeking to submit by an alternative method.

G. The failure to file reports in the required electronic formats or make payments electronically may result in the imposition of penalties and interest in accordance with R.S. 23:1543 and R.S. 23:1660.

AUTHORITY NOTE: Promulgated in accordance with R.S. 23:1631, R.S. 23:1531.1 and R.S. 36:304.

HISTORICAL NOTE: Promulgated by the Workforce Commission, Office of Unemployment Insurance, LR 40:806

(April 2014), amended by the Workforce Commission, Office of Unemployment Insurance Administration, LR 46:364 (March 2020).

**§379. Criminal History Background Check for Access to Federal Tax Information**

**A. Definitions**

*Criminal History Background Checks*—a review of an individual’s criminal history on the national level through the use of fingerprints sent to the Federal Bureau of Investigation (FBI), the state level, through the use of fingerprints sent to the Louisiana Bureau of Criminal Identification and Information and the local level, through various local law enforcement agencies.

*Federal Tax Information (FTI)*—consists of federal tax returns and return information (and information derived from it) that is in the Louisiana Workforce Commission’s possession or control which is covered by the confidentiality protections of the Internal Revenue Code and subject to its safeguarding requirements, including IRS oversight.

**B. Applicability**

1. All prospective Louisiana Workforce Commission employees who will be expected to handle FTI and have signed a conditional job offer, all prospective Louisiana Workforce Commission contractors and subcontractors expected to handle FTI, and all current employees, contractors and subcontractors that handle FTI will submit fingerprints and other identifying information and undergo the following criminal history background checks:

- a. state criminal history record check;
- b. national criminal history record check from the F.B.I.;
- c. check of all local law enforcement agencies where the subject has lived, worked and/or attended school in the last five years.

**C. General Provisions for Criminal History Background Checks**

1. Every current employee, prospective employee, contractor or subcontractor employee identified as having or who will have access to FTI, shall sign a written authorization to have fingerprinting and criminal history background checks performed.

2. Criminal history background checks will be completed at the frequency required by the Internal Revenue Service’s Pub. 1075.

3. Criminal history background checks will only be done on prospective employees after a conditional offer of employment is signed by prospective employee.

4. Criminal history background checks on prospective employees of contractors and subcontractors must be done prior to beginning work on the contract.

**D. Suitability Determination**

1. Unless otherwise excluded from employment under federal or state laws, all criminal conduct revealed by the criminal history background checks will be considered based upon the following criteria:

- a. relevance of criminal record or conduct to the position sought or held;
- b. the nature of the work to be performed;
- c. the time that has elapsed since the conviction or conduct;
- d. the seriousness and specific circumstances of the offense/conduct, including the type of harm caused, and/or the legal elements involved in the specific crime committed;
- e. the number of offenses;
- f. whether the candidate has pending charges;
- g. whether the individual is likely to have committed the offense/conduct;
- h. the nature and gravity of the offense/conduct;
- i. any evidence of rehabilitation or contrition; and
- j. any other relevant information, including that submitted by or on behalf of the final candidate, current employee, contractor or subcontractor, or other information obtained by LWC.

2. If no criminal conduct is revealed by the criminal history background checks, the prospective employee or current employee will be deemed suitable to handle FTI based on the criminal background checks only if the prospective or current employee also is a citizen or legally authorized to work in the U.S. and no other issues involving the trustworthiness of the prospective or current employee arise. Contractors and subcontractors will be determined suitable relevant to the background checks if no criminal conduct is found and all other requirements under IRS Publication 1075 are met.

3. If criminal conduct is discovered by the criminal history background checks, the Louisiana Workforce Commission will consider the criteria and make a suitability determination. If an unfavorable determination is made, the prospective employee, current employee, contractor’s employee or subcontractor’s employee will be notified in writing and will be given 30 days from the date of mailing, as evidenced by the date indicated on the letter, to present documentation to refute the suitability determination. If no documentation is submitted within 30 days, then the suitability determination will be final. If documentation is presented within 30 days, the Louisiana Workforce Commission will review the documentation and either affirm or reverse its original suitability determination. The Louisiana Workforce Commission’s reconsidered determination shall be final. Even if a contractor’s employee or subcontractor’s employee receives a favorable suitability determination or redetermination, if all other requirements provided for by IRS Publication 1075 are not met, the contractor employee’s or subcontractor employee’s access to FTI will be denied or terminated.



E. Consequences of Unsuitability Determinations

1. access or use of FTI will be immediately denied, suspended, or terminated;
2. job offer will be rescinded for prospective employees if unsuitability determination is final;
3. contract may be terminated;
4. contractor’s employee or subcontractor’s employee will be removed or prohibited from performing work;
5. a current employee that receives a determination of unsuitability will have access suspended, and a current employee that receives a final determination of unsuitability will have access to FTI terminated;
6. current employees with access to FTI that receive a final determination of unsuitability may be reassigned or face disciplinary action depending upon the specific circumstances.

F. Nothing in this Rule shall prohibit the Louisiana Workforce Commission from taking adverse action against a prospective employee, or current employee with access to FTI based upon factors other than the outcome of the criminal background checks including, but not limited to, falsifying information on the application, unusual delay in completing or delivering required forms, or any action indicating the individual is unfit for a position of trust. All actions against a classified civil service employee will be taken in accordance with civil service rules.

AUTHORITY NOTE: Promulgated in accordance with R.S. 15:587.5 and R.S. 23:1657.1.

HISTORICAL NOTE: Promulgated by the Workforce Commission, Office of Unemployment Insurance Administration, LR 44:2026 (November 2018), amended LR 48:2995 (December 2022).

**§381. Employer Requirement to Provide Notification of the Availability of Unemployment Insurance Benefits to Each Individual Employee at the Time of Separation**

A. Pursuant to R.S. 23:1621, employers are required to provide notification of the availability of unemployment insurance benefits (UI). This Section prescribes an additional requirement that employers shall notify each individual employee at the time of separation from employment of the following.

1. Employees may file a UI claim in the first week that employment stops or work hours are reduced.
2. Employees shall be informed that a UI claim may be filed by phone or online stating:
  - a. to file a UI claim by phone, call: 1-866-783-5567;
  - b. to file a UI claim online, visit: [www.louisianaworks.net/hire](http://www.louisianaworks.net/hire);
  - c. if you have questions about the status of your UI claim, you can call the LWC at 866-783-5567 or visit [www.louisianaworks.net/hire](http://www.louisianaworks.net/hire).

3. Employees shall be given the Workforce Commission’s toll free phone number and web address for filing and assistance with unemployment insurance claims.

4. Employees shall be informed of the need to provide the Workforce Commission with the following information in order for the claim to be processed:

- a. full legal name;
- b. social security number; and
- c. authorization to work (if not a U.S. Citizen or resident).

B. Employers can find a form containing this required information at [www.laworks.net/Downloads](http://www.laworks.net/Downloads).

C. Employers shall convey this information at the time of separation. This information shall be provided to employees in writing either via flyer, letter, email, or text message.

AUTHORITY NOTE: Promulgated in accordance with R.S. 23:1591, R.S. 23:1472(19)(a)(iii), R.S. 23:1621, and R.S. 36:310.

HISTORICAL NOTE: Promulgated by the Louisiana Workforce Commission, Office of Unemployment Insurance Administration, LR 46:1400 (October 2020).

**Chapter 5. Lost Wage Benefits for Domestic Violence Victims**

**§501. Terminology Pertaining to Lost Wages for Domestic Violence Victims**

A. Definitions

*Domestic Abuse*—includes but is not limited to physical or sexual abuse and any offense against the person as defined in the Criminal Code of Louisiana, except negligent injury and defamation, committed by one family or household member against another. Minors are not excluded. *Domestic abuse* also includes abuse of persons 60 years of age or older and any disabled person 18 years of age or older when committed by an adult child or adult grandchild.

*Family Members*—spouses, former spouses, parents and children stepparents, stepchildren, foster parents and foster children.

*Household Members*—any person of the opposite sex presently or formerly living in the same residence with the defendant as a spouse whether married or not, who is seeking protection under this Part.

AUTHORITY NOTE: Promulgated in accordance with R.S. 23:1653-1654, R.S. 23:1770-1775 and R.S. 23:1471-1713.

HISTORICAL NOTE: Promulgated by the Department of Labor, Office of Unemployment Insurance Administration, LR 33:2663 (December 2007).

**§503. Administration of Funds**

A. Benefits under the Lost Wage Benefits for Domestic Violence Victims Act are provided to individuals who have lost their employment due to domestic violence and who, otherwise, would not be eligible for unemployment insurance benefits. Towards this end, it shall be the agency’s

intent to apply all rules, regulations, and laws of the unemployment insurance program with the exception of those clearly excluded by the statute.

**AUTHORITY NOTE:** Promulgated in accordance with R.S. 23:1653-1654, R.S. 23:1770-1775 and R.S. 23:1471-1713.

**HISTORICAL NOTE:** Promulgated by the Department of Labor, Office of Unemployment Insurance Administration, LR 33:2663 (December 2007).

**§505. Manner of Distribution**

A. The application for and the distribution of benefits under this program shall be in the same manner and using the same methods as those of regular unemployment insurance benefits.

B. The records shall be maintained in a manner that allows for the monitoring and auditing of the program.

**AUTHORITY NOTE:** Promulgated in accordance with R.S. 23:1653-1654, R.S. 23:1770-1775 and R.S. 23:1471-1713.

**HISTORICAL NOTE:** Promulgated by the Department of Labor, Office of Unemployment Insurance Administration, LR 33:2663 (December 2007).

**§507. Maximum Benefit Amount**

A. The total benefit amount payable under the domestic violence victims program will be reduced by any amount paid from regular unemployment benefits and shall not exceed the maximum benefit amount established in the monetary determination of the unemployment insurance claim.

**AUTHORITY NOTE:** Promulgated in accordance with R.S. 23:1653-1654, R.S. 23:1770-1775 and R.S. 23:1471-1713.

**HISTORICAL NOTE:** Promulgated by the Department of Labor, Office of Unemployment Insurance Administration, LR 33:2663 (December 2007).

**§509. Filing Period**

A. A claimant shall be eligible to file one new claim per calendar year. The term "new claim" is the first initial claim filed to request a determination of entitlement to and eligibility for compensation which results in an agency generated document of an appealable monetary determination provided to the potential claimant.

**AUTHORITY NOTE:** Promulgated in accordance with R.S. 23:1653-1654, R.S. 23:1770-1775 and R.S. 23:1471-1713.

**HISTORICAL NOTE:** Promulgated by the Department of Labor, Office of Unemployment Insurance Administration, LR 33:2663 (December 2007).

**§511. Deductions**

A. The following shall not be deducted from benefits of domestic violence victims:

1. severance pay;
2. vacation pay;
3. holiday pay;
4. bonus pay;
5. WARN Act pay;
6. wages in lieu of notice;
7. separation/dismissal pay;
8. tips/gratuities;
9. Workers' Compensation;
10. military retirement pay; and
11. other periodic payment based on previous work.

**AUTHORITY NOTE:** Promulgated in accordance with R.S. 23:1653-1654, R.S. 23:1770-1775 and R.S. 23:1471-1713.

**HISTORICAL NOTE:** Promulgated by the Department of Labor, Office of Unemployment Insurance Administration, LR 33:2664 (December 2007).

**§513. Availability of Claimant**

A. The requirements that an individual must be able to work, available for work and making an active search for work each week will not apply if the conditions that qualified the individual for the program do not permit him/her to work.

**AUTHORITY NOTE:** Promulgated in accordance with R.S. 23:1653-1654, R.S. 23:1770-1775 and R.S. 23:1471-1713.

**HISTORICAL NOTE:** Promulgated by the Department of Labor, Office of Unemployment Insurance Administration, LR 33:2664 (December 2007).

## Title 40

### LABOR AND EMPLOYMENT

#### Part VII. Conditions under Which Minor Labor May Be Used

##### Chapter 1. Minimum Age Standards for Nonagricultural Employment

###### §101. Oppressive Child Labor

A. Oppressive child labor is defined as employment of children under legal minimum ages in specified occupations as listed in the following Paragraphs.

1. Minimum Age 14. This is the minimum age for certain specified occupations which are allowed outside of school hours. These occupations, along with hours and time standards, are listed in LAC 40:VII.103, 201, 203, 301, and 303.

2. At 16 years of age, youths may be employed in any occupation other than a nonagricultural occupation declared hazardous by the Assistant Secretary of Labor after a public hearing, or any occupation prohibited by R.S. 23:161.

**AUTHORITY NOTE:** Promulgated in accordance with R.S. 23:251.

**HISTORICAL NOTE:** Promulgated by the Department of Labor, Office of Labor, LR 7:45 (February 1981), amended LR 15:1086 (December 1989), amended by the Department of Labor, Office of Labor, LR 17:357 (April 1991), amended by the Department of Labor, Office of Regulatory Services, LR 30:2059 (September 2004).

###### §103. Employment Standards for Minors under 16 Years of Age

A. Employment of minors under 16 years of age is limited to certain occupations under conditions which do not interfere with their schooling, health, or well being.

1. Hours and Time Standards. Minors under 16 years of age may not be employed, or permitted, or suffered to work:

a. during school hours, as defined by the local superintendent for the school district in which the minor resides;

b. before 7 a.m. or after 7 p.m. on any day prior to a day during which school is in session or after 9 p.m. on any day prior to a day during which school is not in session;

c. when employed in theatrical performances, the minor may not be present in the theater, nor shall appear in any performance during the below listed periods of time:

- i. more than six hours in any day;
- ii. more than 24 hours in any week;
- iii. between the hours of 11 p.m. and 6 a.m.;

d. when employed in commercial motion picture, film or video productions, or modeling, the minor may not be present in the studio or on the set, nor shall appear in any performance during the below listed periods of time:

i. before 7 a.m. for studio production, 6 a.m. for location productions, and shall end no later than time specified below:

(a). for minors under six years of age, 7 p.m.;

(b). for minors six years of age to 15 years of age, 8 p.m. on any day prior to a day during which school is in session or 10 p.m. on any day prior to a day during which school is not in session, as defined by the local superintendent for the school district in which the minor resides;

ii. minors under six years of age shall not work more than six hours per day; minors six years of age to 15 years of age shall not work more than eight hours per day;

iii. minors shall receive a 12-hour rest break at the end of each work day, before the commencement of the next day of work;

iv. minors shall not be employed more than six consecutive days in any one week, nor more than 36 hours per week for minors under six years of age, nor more than 48 hours per week for minors six years of age to 15 years of age;

v. applications for waivers for any exception to the foregoing provisions of this Subparagraph may be made to the secretary of the Department of Labor or his designee;

vi. the Secretary of Labor or his designee may grant a waiver only under the following circumstances:

(a). written notification through a listing of specific dates and times that the minor(s) shall be employed and/or present for either studio production or location production;

(b). written acknowledgement that the minor's parent(s), tutor, or custodian have been fully informed of the circumstances and have granted advance consent.

**AUTHORITY NOTE:** Promulgated in accordance with R. S. 23:251.

**HISTORICAL NOTE:** Promulgated by the Department of Labor, Office of Labor, LR 7:45 (February 1981), amended LR 15:1086 (December 1989), amended by the Department of Employment and Training, Office of Labor, LR 17:357 (April 1991), amended by the Department of Labor, Office of Labor, LR 20:897 (August 1994), amended by the Department of Labor, Office of Regulatory Services, LR 30:2059 (September 2004).

## Chapter 2. Occupations Permitted for 14 and 15 Year-Old Minors

### §201. Types of Employment

A. Types of employment in which 14 and 15 year-old minors may be employed:

1. office and clerical work (including operation of office machines);
2. cashiering, selling, modeling, art work, work in advertising departments, window trimming, and comparative shopping;
3. price marking and tagging by hand or machine, assembling orders, packing and shelving;
4. bagging and carrying out customers' orders;
5. errand and delivery work by foot, bicycle, and public transportation;
6. cleanup work, including use of vacuum cleaners and floor waxers; and maintenance of grounds, but not including use of power-driven mowers or cutters;
7. kitchen work and other work involved in preparing and serving food and beverages, including operation of machines and devices used in performance of such work, such as, but not limited to, dishwashers, toasters, dumbwaiters, popcorn poppers, milk shake blenders, and coffee grinders;
8. work in connection with cars and trucks if confined to the following:
  - a. dispensing gasoline and oil;
  - b. courtesy service on premises of gasoline service station;
  - c. car cleaning, washing, and polishing;
9. cleaning vegetables and fruits; and wrapping, sealing, weighing, labeling, pricing, and stocking goods when performed in areas physically separated from areas where meat is prepared for sale;
10. selling, offering for sale, soliciting for or displaying articles, goods, merchandise, commercial service, posters, circulars, newspapers, or magazines;
11. delivery of, and collection for newspapers and periodicals;
12. work as a golf caddy.

AUTHORITY NOTE: Promulgated in accordance with R.S. 23:251.

HISTORICAL NOTE: Promulgated by the Department of Labor, Office of Labor, LR 7:45 (February, 1981), amended LR 15:1087 (December 1989), amended by the Department of Labor, Office of Labor, LR 17:357 (April 1991), amended by the Department of Labor, Office of Regulatory Services, LR 30:2060 (September 2004).

### §203. Occupations Permitted for Minors under 16 Years of Age in Theatrical Performances, Exhibitions, Commercial Motion Pictures, Films, Video Productions, or Modeling

A. Minors may be employed in theatrical performances or exhibitions as follows:

1. as a singer, musician, or actor in a church, school or academy;
2. teaching or learning the science or practice of music or singing;
3. as a singer, musician, or actor in a concert or in the presentation of a play or musical comedy under the following conditions:
  - a. not more than nine weekly performances may be presented; and
  - b. a permit must be granted by the Assistant Secretary of Labor at least five days prior to the performance;
4. as a singer, musician, or actor in a play or musical comedy presented by a traveling theatrical company, provided that no more than eight performances are given in any one week. During a week in which a national or state holiday occurs, nine performances may be given under the following conditions:
  - a. a special permit must be obtained from the assistant secretary of the Office of Regulatory Services by the manager of the theater in which the minor is to appear;
  - b. the minor must hold a valid certificate from the state or city where the minor resides which permits participation in theatrical performances;
  - c. in the opinion of the Assistant Secretary of the Office of Regulatory Services, employment in such performances is not detrimental to the health and morals of the minor.

B. Minors may be employed in commercial motion pictures, films, video productions, or modeling, as follows.

1. A duly authorized agent shall make applications for a permit to the Assistant Secretary of the Office of Regulatory Services at least five days before the minor is scheduled to begin work.
2. The Assistant Secretary of the Office of Regulatory Services shall issue permits after satisfying himself that the supervision of the minor is adequate, and that the conditions of employment are not detrimental to the health, morals or safety of the minor.

AUTHORITY NOTE: Promulgated in accordance with R.S. 23:251.

HISTORICAL NOTE: Promulgated by the Department of Labor, Office of Labor, LR 7:45 (February 1981), amended LR 15:1087 (December 1989), amended by the Department of Labor, Office of Labor, LR 17:357 (April 1991), amended by the Department of Labor, Office of Regulatory Services, LR 30:2060 (September 2004).

## Chapter 3. Occupations Not Permitted

### §301. Occupations Not Permitted for 14 and 15 Year-Old Minors

A. Fourteen and 15 year-old minors may not be employed in:

1. any manufacturing occupation;
2. any mining occupation;
3. processing occupations or commercial laundering and dry-cleaning;
4. occupations which require performance of any duties in workrooms or workplaces where goods are manufactured, mined, or otherwise processed, except to the extent expressly permitted in §201;
5. operating or tending hoisting or lifting apparatus or the inflation of any tire mounted on a rim equipped with a removable retaining ring;
6. occupations connected with:
  - a. transportation of persons or property by rail, highway, air, water, pipeline, or other means;
  - b. communications and public utilities, except office and clerical work;
  - c. construction, including repair work;
7. any of the following occupations:
  - a. work performed in or about boiler or engine rooms;
  - b. work in connection with repair of machines or mechanical equipment;
  - c. all work that involves use of ladders and scaffolds or their substitutes;
  - d. cooking and baking;
  - e. occupations which involve operating, setting up, adjusting, cleaning, oiling, or repairing power-driven food slicers and grinders, choppers and cutters, and bakery type mixers;
  - f. work in freezers and meat coolers;
  - g. all work in preparation of meat for sale, except wrapping, sealing, labeling, weighing, pricing, and stocking when such work is not performed in processing areas;
  - h. loading and unloading goods on and off trucks, railroad cars, and conveyors; or
  - i. all occupations in warehouses, except office and clerical work;
8. any occupation about or in connection with power-driven machinery; or
9. any other occupation found and declared to be hazardous by the Assistant Secretary of Labor after a public hearing.

AUTHORITY NOTE: Promulgated in accordance with R.S. 23:251.

HISTORICAL NOTE: Promulgated by the Department of Labor, Office of Labor, LR 7:45 (February 1981), amended LR 15:1088 (December 1989), amended by the Department of Labor, Office of Labor, LR 17:357 (April 1991), amended by the Department of Labor, Office of Regulatory Services, LR 30:2061 (September 2004).

### §303. Employment of Minors 16 and 17 Years of Age

A. Minors may not work in any illegal, indecent, or immoral exhibition or practice, including but not limited to; striptease, exotic dancer, etc.

B. Minors may not work at any occupation which the Assistant Secretary of the Office of Regulatory Services has found and declared to be hazardous for 16 and 17 year-old persons. This minimum age applies even when the minor is employed by a parent or person standing in place of the parent.

C. There are no time standards for minors 16 and 17 years of age regarding the numbers of hours worked per day or per week, however, minors shall receive an eight hour rest break at the end of each work day, before the commencement of the next day of work.

D. No minor 16 years of age who has not graduated from high school shall be employed, or permitted, or suffered to work between the hours of 11 p.m. and 5 a.m. prior to the start of any school day. No minor 17 years of age who has not graduated from high school shall be employed, or permitted, or suffered to work between the hours of 12 a.m. and 5 a.m. prior to the start of any school day. For purposes of this Subparagraph, a minor who has taken and passed a General Education Development test (GED) and who has been awarded a High School Equivalency Diploma from the Louisiana Department of Education will be considered to have graduated from high school.

AUTHORITY NOTE: Promulgated in accordance with R.S. 23:251.

HISTORICAL NOTE: Promulgated by the Department of Labor, Office of Labor, LR 7:45 (February 1981), amended LR 15:1088 (December 1989), amended by the Department of Labor, Office of Labor, LR 17:357 (April 1991), amended by the Department of Labor, Office of Regulatory Services, LR 30:2061 (September 2004).

## Chapter 5. Hazardous Occupations

### §501. Preface

A. In the following Sections certain occupations are listed as hazardous. These occupations are specified both on an industry-wide basis, and on an occupational basis, regardless of the industry in which they are found.

AUTHORITY NOTE: Promulgated in accordance with R.S. 23:161.

HISTORICAL NOTE: Promulgated by the Department of Labor, Office of Labor, LR 7:46 (February 1981), amended by the Department of Labor, Office of Labor, LR 17:357 (April 1991), amended by the Department of Labor, Office of Regulatory Services, LR 30:2061 (September 2004).

**§503. Manufacturing or Storage Operations Involving Explosives****A. Definitions**

*Explosives and Articles Containing Explosives*—ammunition, black powder, blasting caps, high explosives, primers, smokeless powder, and all goods classified and defined as explosives by the Interstate Commerce Commission in regulations governing transportation of explosives and other dangerous substances by common carriers.

*Plant or Establishment Manufacturing or Storing Explosive Articles*—the land with all buildings and structures thereon which are used in connection with manufacturing, processing, or storing explosives or articles which contain explosive components.

**B. Non-Explosive Area**

1. An area which meets all of the following criteria is deemed a non-explosive area.

a. No work performed in the area involves handling or use of explosives.

b. The area is separated from the explosive area by a distance not less than that prescribed in the American Table of Distances for protection of inhabited buildings.

c. The area is separated from the explosive area by a fence or is otherwise located so that it constitutes a designated area.

2. Satisfactory controls have been established to prevent employees under 18 years of age who are working within the area from entering any area in or about the plant which does not meet criteria listed in Subsection C below.

C. Occupations prohibited in plants which manufacture or store explosives. The following occupations in or about any plant or establishment which manufactures or stores explosives are prohibited:

1. all occupations in manufacturing, mixing, transporting, or handling explosive compounds in manufacture of explosives, and all other occupations which require performance of any duties in an explosive area in which explosive compounds are manufactured or mixed;

2. all occupations involved in manufacturing, handling, or transportation of primers, and performance of any other duties in the same building in which primers are manufactured;

3. all occupations involved in priming cartridges, and performance of any other duties in the same room in which cartridges are primed;

4. all occupations involved in plate loading cartridges and in operation of automatic loading machines;

5. all occupations which involve loading, inspecting, packing, storing, and shipping blasting caps; and

6. all other occupations in or about any plant or establishment which manufactures or stores explosives except when such occupation is performed in a non-explosive area.

AUTHORITY NOTE: Promulgated in accordance with R.S. 23:161.

HISTORICAL NOTE: Promulgated by the Department of Labor, Office of Labor, LR 7:46 (February 1981), amended by the Department of Labor, Office of Labor, LR 17:357 (April 1991), amended by the Department of Labor, Office of Regulatory Services, LR 30:2061 (September 2004).

**§505. Occupations Involving Motor Vehicles****A. Definitions**

*Driver*—any individual who, in the course of employment, drives a motor vehicle at any time.

*Gross Vehicle Weight*—the weight of the vehicle chassis, including lubricants, water, and full tank or tanks of fuel, plus the weight of the cab or drivers compartment, body, special chassis and body equipment, and payload.

*Motor Vehicle*—any automobile, truck, truck-trailer combination, trailer, semi-trailers, motorcycle, or similar vehicle which is propelled or drawn by mechanical or electrical power, and designed for use as means of transportation, but does not mean any vehicle operated exclusively on rails.

B. Occupations Prohibited. Any occupation as motor-vehicle driver is prohibited except as permitted in R.S. 23:161 (10) and the Teen Drive for Employment Act which amends the Federal Fair Labor Standards Act, 29 U.S.C. 212 through 213.

AUTHORITY NOTE: Promulgated in accordance with R.S. 23:161.

HISTORICAL NOTE: Promulgated by the Department of Labor, Office of Labor LR 7:46 (February 1981), amended by the Department of Labor, Office of Labor, LR 17:357 (April 1991), amended by the Department of Labor, Office of Regulatory Services, LR 30:2062 (September 2004).

**§507. Occupations in Connection with Mining****A. Definitions**

*Mining Occupations*—all work performed:

- a. underground in mines and quarries;
- b. on the surface at underground mines and underground quarries;
- c. in or about open-cut mines, open quarries, clay pits, and sand and gravel operations;
- d. at or about placer mining operations;
- e. at or about operations dredging for clay, sand or gravel;
- f. at or about bore-hole mining operations;
- g. in or about all metal mills, washer plants, or grinding mills which reduce bulk of extracted minerals; or

h. at or about any crushing, grinding, screening, sizing, washing, or cleansing operations performed upon extracted minerals, except when such operations are performed as part of a manufacturing process outside of area of the mine or quarry.

B. Prohibited Occupations. All occupations in connection with mining or operation of a quarry are prohibited.

AUTHORITY NOTE: Promulgated in accordance with R.S. 23:161.

HISTORICAL NOTE: Adopted by the Department of Labor, Office of Labor, LR 7:46 (February 1981), amended by the Department of Labor, Office of Labor, LR 17:357 (April 1991), amended by the Department of Labor, Office of Regulatory Services, LR 30:2062 (September 2004).

### **§509. Logging and Sawmill Operations**

#### A. Definitions

*Occupations in Logging*—all work performed in connection with felling timber, bucking or converting timber into logs, poles, piles, ties, bolts, pulpwood, chemical wood, excelsior wood, cordwood, fenceposts, or similar products; collecting, skidding, yarding, loading, transporting, and unloading such products in connection with logging; and other work performed in connection with logging that is declared to be hazardous by the assistant secretary of labor.

*Occupations in Sawmilling*—all work performed in connection with the operation of any sawmill, lath mill, shingle mill, or cooperage-stock mill, or in or about any such mill in connection with storing logs and bolts; converting logs or bolts into sawn lumber, laths, shingles, or cooperage-stock, or other products of such mills; or any other work performed in connection with operating any sawmill, lath mill, shingle mill, or cooperage mill.

B. Prohibited Occupations. All occupations in logging and all occupations in operation of any sawmill, lath mill, shingle mill, or cooperage-stock mill are prohibited.

AUTHORITY NOTE: Promulgated in accordance with R.S. 23:161.

HISTORICAL NOTE: Adopted by the Department of Labor, Office of Labor, LR 7:46 (February 1981), amended by the Department of Labor, Office of Labor, LR 17:357 (April 1991), amended by the Department of Labor, Office of Regulatory Services, LR 30:2062 (September 2004).

### **§511. Power Driven Woodworking Machine Occupations**

#### A. Definitions

*Off-Bearing*—removal of material or refuse directly from a saw table or from the point of operation.

*Power-Driven Woodworking Machines*—all fixed or portable machines or tools driven by mechanical or electrical power, and are used or designed for cutting, shaping, forming, nailing, stapling, wire-stitching, fastening, or otherwise assembling, pressing, or printing wood veneer, or other products.

B. Prohibited Occupations. The following occupations involved in operation of power-driven woodworking machines are prohibited:

1. supervising or controlling operation of any woodworking machines;
2. feeding materials into any woodworking machine;
3. helping to feed materials into any woodworking machine;
4. setting up and adjusting, repairing, oiling, or cleaning power-driven woodworking machines;
5. any off-bearing occupations such as removing materials from circular saws and guillotine-action veneer clippers.

C. Operations not considered to be off-bearing are:

1. removal of material or refuse from a circular saw or guillotine-action veneer clipper when such material or refuse has been conveyed away from the saw table or point of operation by a gravity chute or by some mechanical means, such as a moving belt or expulsion device;
2. carrying, moving, or transporting materials from one machine to another, or from one part of the plant to another;
3. piling, stacking or arranging materials to be fed into a machine by another person; and
4. sorting, tying, bundling or loading materials into conveyances.

D. Exemptions. Registered apprentices and registered student-learners are exempt from prohibitions which apply to power-driven woodworking machine occupations.

AUTHORITY NOTE: Promulgated in accordance with R.S. 23:161.

HISTORICAL NOTE: Promulgated by the Department of Labor, Office of Labor, LR 7:47 (February 1981), amended by the Department of Labor, Office of Labor, LR 17:357 (April 1991), amended by the Department of Labor, Office of Regulatory Services, LR 30:2063 (September 2004).

### **§513. Occupations Which Involve Operations of Power-Driven Circular Saws, Band Saws, and Guillotine Shears**

#### A. Definitions

*Band Saw*—a machine which is equipped with an endless steel band which has a continuous series of notches or teeth on one edge. The band runs over wheels or pulleys, and is used to saw material.

*Circular Saw*—a machine which is equipped with a thin steel disc which has a continuous series of notches or teeth on the peripheral edge, mounted on a shaft, and used for sawing materials.

*Guillotine Shears*—a machine which is equipped with a movable cutting blade and is operated vertically to shear material.

*Helper*—any person who assists in operation of a machine by helping to place materials into or remove materials from the machine.

*Machine Equipped with Full Automatic Feed and Ejection*—any machine which is equipped with devices which automatically feed and eject materials, and has a fixed barrier guard to prevent completely an operator or helper from placing any part of his body in the point of operation.

*Operator*—any person who operates a machine by performing the functions of starting or stopping the machine, placing materials into or removing materials from the machine, or any other function directly associated with operation of the machine.

B. Prohibited Occupations. Minors are prohibited from working in all occupations which involve operations of power-driven circular saws, band saws, and guillotine shears except in the operation of machines equipped with full automatic feed and ejection.

C. Exemptions. Registered apprentices and registered student-learners are exempt from prohibitions which apply to power-driven circular saws, band saws, and guillotine shears.

AUTHORITY NOTE: Promulgated in accordance with R.S. 23:161.

HISTORICAL NOTE: Promulgated by the Department of Labor, Office of Labor, LR 7:47 (February 1981), amended by the Department of Labor, Office of Labor, LR 17:357 (April 1991), amended by the Department of Labor, Office of Regulatory Services, LR 30:2063 (September 2004).

#### **§515. Power-Driven Metal-Forming, Rolling, Punching, and Shearing Machine Occupations**

##### A. Definitions

*Forming, Rolling, Punching, and Shearing Machines*—power-driven metal-working machines which change the shape of or cut metals by means of tools, such as dies, rolls, or knives which are mounted on rams, plungers, or other moving devices.

*Helper*—any person who assists in the operation of a machine by helping place materials into or removing materials from the machine.

*Operator*—any person who operates a machine by performing such functions as starting or stopping the machine, placing materials into or removing materials from the machine, or any other function which is directly involved in operation of the machine.

B. Prohibited Occupations. Minors are prohibited from working in occupations as operator or helper on:

1. all rolling machines, such as beading, straightening, corrugating, flanging, or bending rolls; and on hot or cold rolling mills;

2. all pressing or punching machines, except those which are provided with full automatic feed and ejection, and with a fixed barrier guard to prevent the hands or fingers

of the operator from entering the area between the dies or cutting surfaces;

3. all bending machines, such as apron brakes and press brakes;

4. all hammering machines, such as drop-hammers and power hammers;

5. all shearing machines, such as guillotine or squaring shears, alligator shears and rotary shears;

6. or in setting up, adjusting, repairing, oiling, or cleaning any type of machine described in §515.B.1-5 above, including those with automatic feed and ejection.

C. Exemptions. Registered apprentices and registered student-learners are exempt from prohibitions which apply to power-driven metal-forming, rolling, punching, and shearing machine occupations.

AUTHORITY NOTE: Promulgated in accordance with R.S. 23:161.

HISTORICAL NOTE: Promulgated by the Department of Labor, Office of Labor, LR 7:47 (February 1981), amended by the Department of Labor, Office of Labor, LR 17:357 (April 1991), amended by the Department of Labor, Office of Regulatory Services, LR 30:2063 (September 2004).

#### **§517. Power-Driven Paper-Product Machine Occupations**

##### A. Definitions

*Operating or Assisting to Operate*—all work involved in starting, stopping, loading materials into, and removing materials from a machine or other work directly involved in operating the machine.

*Paper Products Machine*—any power-driven machine used to manufacture or convert paper or pulp into a finished product. The term is understood to apply to such machines whether they are used in establishments that manufacture converted paper pulp products, or in any other type of manufacturing or non-manufacturing establishment.

##### B. Prohibited Occupations

1. Minors are prohibited from operating or assisting to operate any of the following or similar machines: Arm-type wirestitcher, stapler, circular or band saw, corner cutter or mitering machine, corrugating and single or double facing machine, envelope die-cutting press, guillotine paper cutter or shear, horizontal bar scorer, laminating or combining machine, sheeting machine, scrap paper baler or vertical slotter, platen die-cutting press, platen printing press and punch press which involves hand-feeding.

2. Minors are prohibited from setting up, adjusting, repairing, oiling, or cleaning above machines, including those which do not involve hand-feeding.

C. Exemptions. Registered apprentices and registered student-learners are exempt from all prohibitions in occupations involving power-driven paper-product machines and equipment.



**AUTHORITY NOTE:** Promulgated in accordance with R.S. 23:161.

**HISTORICAL NOTE:** Promulgated by the Department of Labor, Office of Labor, LR 7:47 (February 1981), amended by the Department of Labor, Office of Labor, LR 17:357 (April 1991), amended by the Department of Labor, Office of Regulatory Services, LR 30:2064 (September 2004).

### §519. Power Driven Bakery Machine Occupations

A. Prohibited Occupations. Minors are prohibited from engaging in the following occupations: operating, assisting to operate, or setting up, adjusting, repairing, oiling, or cleaning any horizontal dough mixer, batter mixer, bread dividing, rounding, or molding machine; dough brake, dough sheeter, combination slicing and wrapping machine; cake cutting band saw; setting up or adjusting a cookie or cracker machine.

B. Exception. Sixteen or 17 year old minors are not prohibited from operating pizza dough rollers constructed with safeguards contained in the basic design so as to prevent fingers, hands, or clothing from being caught in the in-running point of the rollers; which have gears that are completely enclosed, and have microswitches that disengage the machinery if the backs or sides of the rollers are removed; provided that such safeguards are present on the machine, are operational, and cannot be overridden.

C. Exemption. Registered apprentices are exempt from all prohibitions affecting occupations involving power-driven baking equipment and machines.

**AUTHORITY NOTE:** Promulgated in accordance with R.S. 23:161.

**HISTORICAL NOTE:** Promulgated by the Department of Labor, Office of Labor LR 7:47 (February 1981), amended by the Department of Labor, Office of Labor, LR 17:357 (April 1991), amended by the Department of Labor, Office of Regulatory Services, LR 30:2064 (September 2004).

### §521. Power Driven Hoisting Apparatus Occupations

#### A. Definitions

*Automatic Elevator*—a passenger elevator, freight elevator, or a combination freight-passenger elevator. Such elevator is controlled by pushbuttons in such a manner that starting, stopping, going to a landing and holding, and opening and closing car and hoistway doors is entirely automatic.

*Automatic Signal Operation Elevator*—an elevator which is started in response to operation of a switch in the car which, when operated by the operator, actuates a starting device which automatically closes the car and hoistway doors, controls movement of the car to a selected landing, holds it when it arrives, and automatically opens the car and hoistway doors.

*Crane*—a power-driven machine used for lifting and lowering a load and moving it horizontally. The hoisting mechanism is an integral part of the machine. Included are cantilever gantry, crawler, gantry, hammerhead, ingot-pouring, locomotive, motor truck, overhead traveling, pillar

jib, pintle, portal, semi-gantry, semi-portal, storage bridge, tower, walking jib, and wall cranes.

*Derrick*—a power-driven apparatus which consists of a mast or equivalent members held at the top by guys or braces, with or without a boom, for use with a hoisting mechanism and operating ropes. All types of derricks are included, such as A-frame, breast, Chicago boom, gin-pole, guy, and stiff leg derricks.

*Elevator*—any power-driven hoisting or lowering mechanism equipped with a car or platform which moves in guides in a substantially vertical direction. Both passenger and freight elevators are included (also portable elevators and tiering machines). Dumbwaiters are not included.

*High-Lift Truck*—a power-driven industrial type truck used for lateral transportation, and is equipped with a power-lifting device, usually in the form of a fork or platform capable of tiering loaded pallets one above the other. Instead of a fork or platform, the lifting device may consist of a ram, shovel, scoop, crane, revolving fork, or other attachments for handling specific loads. Such trucks may be known as forklifts, fork trucks, tiering or stacking trucks, front-end loaders, or graders. Not included are low-lift, or low-lift platform trucks which are designed for transportation of, but not tiering of, materials.

*Hoist*—any power driven apparatus used for raising or lowering a load by application of a pulling force. This includes all types of hoists, such as base-mounted electric, clevis suspension, hood suspension, monorail, overhead electric, simple drum, and trolley suspension hoists.

*Manlift*—a device which is intended for conveyance of persons. It consists of platforms or brackets mounted on, or attached to, an endless belt, cable, chain, or similar suspension device. Such chain device operates in a substantially vertical direction, and is supported by, and driven through pulleys, sheaves, or sprockets at top and bottom.

B. Prohibited Occupations. The following occupations are prohibited for minors:

1. operating a crane, derrick, elevator, hoist, or high-lift truck;
2. work which involves riding in a manlift or on a freight elevator, except a freight elevator operated by an assigned operator;
3. assisting in operation of a crane, derrick or hoist; or in work performed by crane;
4. hookers, crane chasers, hookers-on, riggers, rigger helper, and similar occupations.

C. Exemptions. Registered apprentices are exempt from all prohibitions affecting occupations involving power-driven hoisting apparatus.

**AUTHORITY NOTE:** Promulgated in accordance with R.S. 23:161.

**HISTORICAL NOTE:** Promulgated by the Department of Labor, Office of Labor, LR 7:48 (February 1981), amended by the

Department of Labor, Office of Labor, LR 17:357 (April 1991), amended by the Department of Labor, Office of Regulatory Services, LR 30:2064 (September 2004).

### **§523. Wrecking, Demolition, and Shipbreaking Occupations**

A. Prohibited Occupations. All work in wrecking, demolition, and shipbreaking is prohibited. This includes cleanup and salvage work, performed at the site of total or partial razing, demolishing, or dismantling a building, tower, bridge, steeple, chimney, or other structure, ship, or other vessel.

B. Exemptions. Registered apprentices are exempt from prohibitions which apply to occupations in wrecking, demolition, and shipbreaking.

AUTHORITY NOTE: Promulgated in accordance with R.S. 23:161.

HISTORICAL NOTE: Promulgated by the Department of Labor, Office of Labor, LR 7:48 (February 1981), amended by the Department of Labor, Office of Labor, LR 17:357 (April 1991), amended by the Department of Labor, Office of Regulatory Services, LR 30:2065 (September 2004).

### **§525. Brick, Tile and Kindred Products Manufacturing Occupations**

A. Prohibited Occupations. All work in and about establishments in which clay construction products and silica brick are manufactured and in other silica refractories is prohibited with the exceptions listed in §525.B below.

B. Exemptions. Registered apprentices are exempt from prohibitions which apply to occupations in manufacture of brick, tile and kindred products.

AUTHORITY NOTE: Promulgated in accordance with R.S. 23:161.

HISTORICAL NOTE: Promulgated by the Department of Labor, Office of Labor, LR 7:48 (February 1981), amended by the Department of Labor, Office of Labor, LR 17:357 (April 1991), amended by the Department of Labor, Office of Regulatory Services, LR 30:2065 (September 2004).

### **§527. Roofing Occupations**

A. All occupations in roofing operations are prohibited. These include:

1. installation of roofs, including related metal work, such as flashing, etc.;
2. alterations, additions, maintenance, and repair, including painting and coating existing roofs.

B. Exemptions. Registered apprentices and registered student-learners are exempt from prohibitions which apply to occupations in roofing operations.

AUTHORITY NOTE: Promulgated in accordance with R.S. 23:161.

HISTORICAL NOTE: Promulgated by the Department of Labor, Office of Labor, LR 7:48 (February 1981), amended by the Department of Labor, Office of Labor, LR 17:357 (April 1991), amended by the Department of Labor, Office of Regulatory Services, LR 30:2065 (September 2004).

### **§529. Excavation Occupations**

A. Prohibited Occupations. The following occupations are prohibited to minors:

1. excavating, working in, or backfilling trenches which exceed 4 feet in depth at any point;
2. excavating for buildings or other structures, or working in such excavations which exceed 4 feet in depth at any point;
3. working within tunnels prior to completion of all driving and shoring operations; and
4. working within shafts prior to the completion of all sinking and shoring operations.

B. Exemptions. Registered apprentices and registered student-learners are exempt from the prohibitions which apply to occupations in excavation work.

AUTHORITY NOTE: Promulgated in accordance with R.S. 23:161.

HISTORICAL NOTE: Promulgated by the Department of Labor, Office of Labor, LR 7:48 (February 1981), amended by the Department of Labor, Office of Labor, LR 17:357 (April 1991), amended by the Department of Labor, Office of Regulatory Services, LR 30:2065 (September 2004).

### **§531. Slaughtering, Meat-Packing or Processing, or Rendering Occupations**

#### **A. Definitions**

*Boning Occupation*—an occupation which involves removal of bones from meat cuts. It does not include scraping or trimming meat from cuts containing bones.

*Curing Cellar*—a workroom or workplace which is primarily devoted to preservation and flavoring meat by curing materials. It does not include an area where meat is smoked.

*Hide Cellar*—a workroom or workplace in which hides are graded, trimmed, slated, and otherwise cured.

*Killing Floor*—the workroom or workplace in which cattle, hogs, calves, sheep, lambs, goats, or other animals are immobilized, shackled, or killed, and the carcasses are dressed prior to being chilled.

*Rendering Plant*—any establishment engaged in conversion of dead animals, animal offal, animal fats, scrap meats, blood, and bones into stock feed, tallow, inedible greases, fertilizer ingredients, and similar products.

*Slaughtering and Meat-Packing Establishment*—places in and about which cattle, calves, hogs, sheep, lambs, goats, or other animals are killed, butchered, or processed. Included are establishments which manufacture or process meat products or sausage casings from such animals.

B. Prohibited Occupations. The following occupations are prohibited:

1. all occupations on the killing floor, in curing cellars, and in hide cellars;

2. all occupations involved in recovery of lard and oils;

3. all occupations involved in tankage or rendering whether or not in a rendering plant, or a slaughter house;

4. all occupations involved in operating, setting up, adjusting, oiling, or cleaning any power-driven machine used in a slaughtering, meat-packing or processing, or rendering plant;

5. all boning work;

6. all occupations which involve pushing or dropping any suspended carcass, half carcass, or quarter carcass;

7. all occupations involving hand carrying any carcass or half carcass of beef, pork, or horse, or any quarter carcass of beef or horse.

C. Exemptions. Registered apprentices and registered student learners are exempt from prohibitions which apply to occupations involved in slaughtering, meat-packing or processing, or rendering.

AUTHORITY NOTE: Promulgated in accordance with R.S. 23:161.

HISTORICAL NOTE: Promulgated by the Department of Labor, Office of Labor, LR 7:48 (February 1981), amended by the Department of Labor, Office of Labor, LR 17:357 (April 1991), amended by the Department of Labor, Office of Regulatory Services, LR 30:2065 (September 2004).

### **§533. Occupations Involving Exposure to Radioactive Substances and Ionizing Radiation**

A. All work is prohibited in any workroom in which:

1. radium is stored or used in the manufacture of self-luminous compounds;

2. self-luminous compounds are manufactured, processed, or packaged;

3. self-luminous compounds are stored, used, or worked on;

4. incandescent mantles are made from fabric and solutions containing thorium salts, or where these are packaged or stored;

5. other radioactive substances are present in the air in average concentrations exceeding 10 percent of the maximum permissible concentration in air recommended for exposure by the national Committee on Radiation Protection as set forth in the 40-hour week column of Table One of the National Bureau of Standards, Handbook No. 69, entitled Maximum Permissible Body Burdens and Maximum Permissible Concentrations of Radionuclides in Air and Water for Occupational Exposure, issued June 5, 1959; or

6. any other work which involves exposure to ionizing radiations in excess of 0.5 rem per year.

AUTHORITY NOTE: Promulgated in accordance with R.S. 23:161.

HISTORICAL NOTE: Promulgated by the Department of Labor, Office of Labor, LR 7:49 (February 1981), amended by the Department of Labor, Office of Labor, LR 17:357 (April 1991),

amended by the Department of Labor, Office of Regulatory Services, LR 30:2066 (September 2004).

### **§535. Occupations Involving Use of or Contact with Lead or any Other Toxic Substance**

A. Any occupation which involves use of or contact with any toxic substance is prohibited. Such occupations include spray painting, transporting, or physically handling such substance.

AUTHORITY NOTE: Promulgated in accordance with R.S. 23:161.

HISTORICAL NOTE: Promulgated by the Department of Labor, Office of Labor, LR 7:49 (February 1981), amended by the Department of Labor, Office of Labor, LR 17:357 (April 1991), amended by the Department of Labor, Office of Regulatory Services, LR 30:2066 (September 2004).

### **§537. Welding Occupations**

A. Definitions

*Soldering, and Brazing Welding Equipment*—oxygen and acetylene tanks, acetylene torches, assorted tips and soldering and brazing rods used to apply heat to melt the rods and to fuse the pieces to form a permanent bond.

*Welding and Cutting Equipment*—oxygen and acetylene tanks, acetylene torches, cutting tips, carbon arc cutting equipment, gouging machines, chipping hammers, wire brushes, power grinders, etc.

*Welding Machines*—shielded metal arc welding machines, gas tungsten arc welding machines, flux-cored arc welding machines, gas metal arc welding machines, and similar machines used to apply heat to a welding rod or continuously fed wire and to metal pieces, melting and fusing the pieces to form a permanent bond.

B. Prohibited Occupations. Minors are prohibited from working as an operator or helper in the operation of any of the above described machines or equipment.

C. Registered apprentices and registered student-learners are exempt from the prohibitions which apply to operations in welding occupations.

AUTHORITY NOTE: Promulgated in accordance with R.S. 23:161.

HISTORICAL NOTE: Promulgated by the Department of Labor, Office of Regulatory Services, LR 30:2066 (September 2004).

### **§539. Registered Apprentices**

A. For purposes of this Chapter, *registered apprentices* means minors participating in job training programs which have been approved and registered by the Louisiana Department of Labor, Apprenticeship Division in accordance with R.S.23:381, et seq.

B. Registered apprentices are exempt from hazardous occupations prohibitions while participating in job training as an indentured apprentice in a registered program.

AUTHORITY NOTE: Promulgated in accordance with R.S. 23:161.

## LABOR AND EMPLOYMENT

HISTORICAL NOTE: Promulgated by the Department of Labor, Office of Regulatory Services, LR 30:2066 (September 2004).

### §541. Registered Student Learners

A. For purposes of this Chapter, *registered student learners* means minor students participating in job training programs approved by and administered by the Louisiana Office of Career and Technical Education or the Louisiana Community and Technical College System.

B. Registered Student Learners may be exempt from hazardous occupation prohibitions concerning the following equipment and job tasks, provided that all conditions of Subsection C below are met:

1. power-driven woodworking machines;
2. power-driven circular saws, band saws, and guillotine shears;
3. power-driven metal-forming, punching and shearing machines;
4. power-driven paper product machines;
5. roofing operations;
6. excavation operations;
7. slaughtering, meat-packing or processing, or rendering;

8. welding operations.

### C. Conditions

1. Such student learner is employed under a written agreement which provides:

a. that the work of the student learner in the occupations declared hazardous shall be incidental to the training;

b. that such work shall be intermittent and for short periods of time and under the direct and close supervision of a qualified and experienced person;

c. that safety instruction shall be given by the school and correlated by the employer with on-the-job training;

d. that a schedule of organized and progressive work processes to be performed on the job shall have been prepared and made a part of the written agreement; and

e. that the written agreement be signed by the school coordinator, the employer, the minor student learner and the student's consenting parent or guardian.

AUTHORITY NOTE: Promulgated in accordance with R.S. 23:161.

HISTORICAL NOTE: Promulgated by the Department of Labor, Office of Regulatory Services, LR 30:2066 (September 2004).

**Title 40**  
**LABOR AND EMPLOYMENT**  
**Part IX. Apprenticeship**

**Chapter 1. Apprenticeship Laws**

**§101. Definitions**

*Apprentice*—a person at least 16 years of age, who has entered into a written apprenticeship agreement with an employer, an association of employers, or an organization of employees, providing for not less than 2,000 hours of reasonable continuous employment and for participation in an approved program of training through employment and through education in related and supplemental subjects. No local ordinance of any political subdivision of the state shall cause any person identified as an apprentice by such political subdivision to be recognized as an apprentice by the Louisiana Workforce Commission, Apprenticeship Division.

*Apprenticeship Program/Program Sponsor*—a program registered with the Louisiana Workforce Commission, Apprenticeship Division meeting the minimum standards of the state apprenticeship law, which has been approved by both the director of apprenticeship and the State Apprenticeship Council.

*Commission*—the Louisiana Workforce Commission.

*Director*—the director of apprenticeship for the Louisiana Workforce Commission.

*Employer*—any person or organization employing an apprentice whether or not the apprentice is enrolled with such person or organization, or with some other person or organization, as an employer.

*Executive Director*—the executive head and chief administrative officer of the Louisiana Workforce Commission, or any person specifically designated by the executive director.

*Louisiana Workforce Commission, Apprenticeship Division*—the division within Louisiana state government that is recognized by the Office of Apprenticeship, United States Department of Labor as the official state apprenticeship agency of record for registration of apprenticeship programs for federal purposes.

*Sponsor*—any person or organization operating a state apprenticeship program, irrespective of whether such person or organization is an employer as a sponsor.

*State Apprenticeship Council (SAC)*—the Louisiana State Apprenticeship Council, serving as the advisory board to the Louisiana Workforce Commission.

AUTHORITY NOTE: Promulgated in accordance with R.S. 23:381-391.

HISTORICAL NOTE: Promulgated by the Department of Labor, Office of Labor, LR 12:428 (July 1986), amended LR

17:356 (April 1991), amended by the Louisiana Workforce Commission, Office of Workforce Development, LR 37:2209 (July 2011), amended by the Louisiana Workforce Commission, Office of Workforce Development, LR 37:2210 (July 2011).

**§103. Purpose of the Louisiana Apprenticeship System**

A. To provide for voluntary apprenticeship under approved apprenticeship agreements and for the execution and approval of such agreements.

B. To open to the people of Louisiana the opportunity to obtain special training which will equip them for profitable employment and a high type of citizenship.

C. To set up as a means to this end a program of voluntary apprenticeship under approved standards of apprenticeship, reviewed by the State Apprenticeship Council and registered with the Louisiana Workforce Commission, Apprenticeship Division, providing facilities for apprenticeship training and guidance in the arts and crafts of industry and trade, with parallel instruction in related and theoretical education.

D. To relate the supply of skilled workers to industry employment demands.

E. To establish standards for apprenticeship training.

F. To provide for a director of apprenticeship with the Louisiana Workforce Commission.

G. To provide for reports to the legislature and the public regarding the status of apprenticeship training in the state.

H. To establish a procedure for the hearing and adjustment of apprenticeship agreement controversies.

I. To accomplish related ends.

AUTHORITY NOTE: Promulgated in accordance with R.S. 23:381-391.

HISTORICAL NOTE: Promulgated by the Department of Labor, Office of Labor, LR 12:428 (July 1986), amended LR 17:356 (April 1991), amended by the Louisiana Workforce Commission, Office of Workforce Development, LR 37:2210 (July 2011).

**§105. State Apprenticeship Council**

A. The executive director of the Louisiana Workforce Commission shall appoint a State Apprenticeship Council as follows:

1. three representatives of employers who have been selected from recommendations made by employer organizations that are party to a registered apprenticeship program, and three representatives of labor organizations who are nominated by state labor federations, who are also party to a Louisiana-approved apprenticeship program;

2. two members representing the general public;
3. the state official in charge of trade and industrial education with the Louisiana Community and Technical College System shall serve in an ex-officio capacity;
4. each member shall be appointed for three years;
5. any member appointed to fill a vacancy occurring prior to the expiration of the term of their predecessor shall be appointed for the remainder of said term;
6. each member of the council not otherwise compensated by public funds, may be reimbursed for transportation and shall be paid not more than \$35 per day for each day spent in attendance at meetings of the apprenticeship council, which shall meet at the call of the director of apprenticeship; and
7. in order to be considered for appointment to the council, members must be party to a registered apprenticeship program and well versed in the apprenticeship system and apprenticeable occupations, or have previously served on the council for ten or more years.

AUTHORITY NOTE: Promulgated in accordance with R.S. 23:381-391.

HISTORICAL NOTE: Promulgated by the Department of Labor, Office of Labor, LR 12:428 (July 1986), amended LR 17:356 (April 1991), amended by the Louisiana Workforce Commission, Office of Workforce Development, LR 37:2210 (July 2011).

**§107. Duties and Responsibilities of the State Apprenticeship Council**

A. The State Apprenticeship Council shall:

1. aid in formulating policies for the effective administration of the State Apprenticeship System;
2. establish standards which shall represent the minimum standards required for approval of apprenticeship program standards for any proposed apprenticeship program sponsor making application for registration of a program;
3. recommend such rules and regulations as may be necessary to carry out the purpose and intent thereof;
4. perform such other functions as the executive director may direct;
5. assure an opportunity for Louisiana citizens to obtain training that will equip them for profitable employment and promote employment opportunities for them under conditions providing adequate training and reasonable earnings as stated in section 381 of the Louisiana Apprenticeship Law;
6. when the State Apprenticeship Council determines that there is reasonable cause to believe that an apprenticeship program is not operating in accordance with these rules and the Louisiana Apprenticeship Law, and voluntary corrective action has not been taken by the program sponsor, the State Apprenticeship Council shall recommend that the director of apprenticeship institute proceedings to deregister the apprenticeship program and

shall request the director to make a final decision on the basis of available evidence;

7. upon receipt of proposed standards by the Louisiana Workforce Commission, Apprenticeship Division of new programs or previously approved programs, such standards shall be submitted to the State Apprenticeship Council for its review and recommendation to the director of apprenticeship, who will issue the final decision regarding approval or disapproval thereof. When an apprenticeship program has been deregistered for cause or voluntarily deregistered in accordance with the provisions set forth in §309 of this Chapter and Title 29 CFR 29.8 and 29.10, they shall not be granted another program for at least one year from the date of deregistration. A compliance review is to be conducted and the program must be in compliance with these rules, standards and the Louisiana plan for EEO.

AUTHORITY NOTE: Promulgated in accordance with R.S. 23:381-391.

HISTORICAL NOTE: Promulgated by the Department of Labor, Office of Labor, LR 12:428 (July 1986), amended LR 17:356 (April 1991), amended by the Louisiana Workforce Commission, Office of Workforce Development, LR 37:2210 (July 2011).

**§109. Powers and Duties of the Director of Apprenticeship**

A. The director of apprenticeship, under the supervision of the executive director of the Louisiana Workforce Commission, and with the advice and guidance of the state apprenticeship council, is authorized to administer the provisions of the Louisiana Apprenticeship Law (R.S. 23:381 et seq.). The director of apprenticeship shall perform the following functions:

1. in cooperation with the state apprenticeship council, set up conditions and training standards for apprenticeship agreements, which shall in no case be lower than those prescribed by the Louisiana Apprenticeship Law;
2. act as secretary of the state apprenticeship council;
3. approve any apprenticeship agreement which meets the standards established for an apprenticeship program properly registered with the Louisiana Workforce Commission, Apprenticeship Division;
4. terminate or cancel any apprenticeship agreement in accordance with the provisions of such agreement or the minimum standards for that approved program;
5. keep a record of apprenticeship agreements and their disposition;
6. issue certificates of completion of apprenticeship;
7. evaluate performance of registered apprenticeship programs using tools and factors that include, but are not limited to quality assurance assessments, Equal Employment Opportunity (EEO) reviews and program completion rates;
8. perform such other duties as are necessary to carry out the terms and conditions provided in the State Apprenticeship Standards; and

9. when it is the opinion of the director of apprenticeship, or in the opinion of the State Apprenticeship Council it is needed, the director of apprenticeship may request survey information to justify journeyworker wages being paid by employers. This information shall include employer's name, address and telephone number, journeyworker wage and any other information the director of apprenticeship feels is needed. Failure to submit all of such information as requested shall constitute a violation of these rules and shall subject the apprenticeship program sponsor to deregistration of its apprenticeship program;

a. a complete list of affiliated employers shall be updated and submitted to the director of apprenticeship on an annual basis for such purposes;

10. provide technical assistance to employers who strive to sponsor a registered apprenticeship program with the development of their proposed apprenticeship standards; review proposed standards for adherence to state and federal requirements; issue preliminary approval of new programs, pending concurrence by the State Apprenticeship Council; issue one year provisional registration of new programs and certificate of full registration pending that said program is found in compliance of its standards of apprenticeship after the first year of operation.

AUTHORITY NOTE: Promulgated in accordance with R.S. 23:381-391.

HISTORICAL NOTE: Promulgated by the Department of Labor, Office of Labor, LR 12:428 (July 1986), amended LR 17:356 (April 1991), amended by the Louisiana Workforce Commission, Office of Workforce Development, LR 37:2211 (July 2011).

## Chapter 3. Apprenticeship Division Standards and Procedure

### §301. Standards of Apprenticeship

A. An apprenticeship program, to be eligible for registration/approval by the Louisiana Workforce Commission, Apprenticeship Division shall conform to the following standards.

1. All apprenticeship programs proposed for adoption shall be required to submit standards of apprenticeship on forms supplied by the Apprenticeship Division. All standards of apprenticeship shall first be submitted to the director of apprenticeship, who, within 90 days and after careful review, shall make a recommendation to the State Apprenticeship Council for approval if all minimum standards have been met.

a. All other notifications and requests for changes and updates relating to a program sponsor's standards of apprenticeship shall be submitted to the director of apprenticeship within 45 days.

2. The program shall have an organized, written plan embodying the terms and conditions of employment, training, and supervision of one or more apprentices in the apprenticeable occupation, as defined in this Part, and subscribed to by a sponsor who has undertaken to carry out

the apprentice program and shall contain a statement as to whether or not the apprentice will be compensated for the required school time. The written plan shall also state the names and affiliation of each employer and employee representative and its Joint Apprenticeship Committee.

3. The program standards shall contain the state plan for implementing Title 29 CFR Part 30, Equal Employment Opportunity in Apprenticeship and Training, which plan is made a part of these rules and additional provisions concerning the following:

a. the employment and training of the apprentice in a skilled trade;

b. the term of apprenticeship, which for an individual apprentice may be measured either through the completion of the industry standard for on-the-job learning (at least 2,000 hours) (time-based approach), the attainment of competency (competency-based approach), or a blend of the time-based and competency-based approaches (hybrid approach), as defined in 29 CFR 29.5;

i. the determination of the appropriate approach for the program standards is made by the program sponsor, subject to approval by the registration agency of the determination as appropriate to the apprenticeable occupation for which the program standards are registered;

c. an outline of the work processes in which the apprentice will receive supervised work experience and training on the job, and the allocation of the approximate time to be spent in each major process;

d. provision for organized, related and supplemental instruction in technical subjects related to the trade. A minimum of 144 hours of instruction for each year of the apprenticeship shall be required. This instruction in technical subjects may be accomplished through media such as classroom, occupational or industry courses, electronic media, or other instruction approved by the Workforce Commission, Apprenticeship Division. Also a statement showing where and when the related instruction will be administered shall be contained in the standards;

e. a progressively increasing schedule of wages to be paid the apprentice consistent with the skill acquired. The entry wage shall not be less than the minimum wage prescribed by the Fair Labor Standards Act, where applicable, unless a higher wage is required by other applicable federal law, state law, respective regulations, or by collective bargaining agreements. The journeyworker wage rate upon which the apprentices' wages are to be based shall be set by the program sponsor and approved by the director of apprenticeship and State Apprenticeship Council in accordance with the following criteria listed in priority order:

i. the journeyworker wage rate set by the applicable collective bargaining agreement pertinent to an existing registered apprenticeship program in the same area and for the same trade as the proposed apprenticeship program;

## LABOR AND EMPLOYMENT

ii. the higher of the prevailing wage for the craft for the area as set by the U.S. Department of Labor pursuant to the Davis-Bacon Act and published in the *Federal Register*;

iii. in the event that an apprenticeship program is proposed for a craft in an area where there is no pertinent collective bargaining agreement, Davis-Bacon prevailing wage rate, or local prevailing wage rate, the Apprenticeship Division, based on information gathered by its staff through annual wage surveys, may set a journeyworker wage rate for the specific area and craft, to be incorporated into the proposed standards;

f. periodic review and evaluation of the apprentice's progress in job performance and related instruction; and the maintenance of appropriate progress reports. All programs registered with Louisiana Workforce Commission, Apprenticeship Division shall maintain records on each apprentice in their program as to the hours of employment, work experience and related supplemental instruction;

g. the numeric ratio of apprentices to journeyworkers consistent with proper supervision, training, safety, and continuity of employment, and applicable provisions in collective bargaining agreements, except where such ratios are expressly prohibited by the collective bargaining agreements. The ratio language shall be specific and clear as to application in terms of jobsite, work force, department or plant; and in no instance shall such ratio provide for more than one apprentice for each journeyworker employed per jobsite;

h. a probationary period reasonable in relation to the full apprenticeship term, with full credit given for such period toward completion of apprenticeship, and where the probationary period does not exceed 25 percent of the length of the program, or 1 year, whichever is shorter;

i. adequate and safe equipment and facilities for training, and supervision, and safety training for apprentices on the job and in related instruction;

j. the minimum qualifications required by a sponsor for persons entering the apprenticeship program, with an eligible starting age not less than 16 years;

k. the placement of an apprentice under a written apprenticeship agreement as required by the state apprenticeship law and regulations. The agreement shall directly, or by reference, incorporate the standards of the program as part of the agreement;

l. the granting of credit for previously acquired experience, training, or skills for all applicants equally, with commensurate wages for any progression step so granted;

m. transfer of program sponsor's training obligation when the program sponsor is unable to fulfill its obligation under the apprenticeship agreement to another program sponsor, within the same trade, with the written consent of the apprentice and both program sponsors, subject to the approval of the director of apprenticeship;

n. assurance of qualified training personnel and adequate supervision on the job;

o. recognition for successful completion of apprenticeship is evidence by an appropriate certificate of completion;

p. identification of the registration agency;

q. provision for the registration, cancellation and deregistration of the program; and requirement for the prompt submission of any proposed modification or amendment thereto;

r. provision for registration of apprenticeship agreements, modifications, and amendments; notice to the registration office of persons who have successfully completed apprenticeship programs; and notice of cancellations, suspensions and terminations of apprenticeship agreements and causes therefor;

s. authority for the termination of an apprenticeship agreement during the probationary period by either party without stated cause;

t. name and address of the appropriate person authorized by the program sponsor to receive, process and make disposition of complaints; and

u. recording and maintenance of all records concerning apprenticeship as may be required by Louisiana Workforce Commission, Apprenticeship Division and other applicable laws;

v. any trade having been previously approved for training for a particular apprenticeship training program sponsor which has had no activity for a period of two years, may be canceled from the list of approved trades contained in the apprenticeship standards for such program sponsor.

4. Apprenticeship instructors must meet the state Department of Education's requirements for a vocational-technical instructor, or be a subject matter expert, which is an individual, such as a journeyworker, who is recognized within an industry as having expertise in a specific occupation. In order to be considered a subject matter expert in a particular trade, an instructor must hold a registered apprenticeship certificate of completion, or a similar trade specific credential recognized industry-wide, and have training in teaching techniques and adult learning styles, which may occur before or after the apprenticeship instructor has started to provide the related technical instruction.

B. Reciprocity. The Louisiana Workforce Commission, Apprenticeship Division shall accord reciprocal approval for federal purposes to apprentices, apprenticeship programs and standards that are registered in other states by the Office of Apprenticeship or another state registration agency if such reciprocity is requested by the apprenticeship program sponsor. Program sponsors seeking reciprocal approval must meet the wage and hour provisions and apprentice ratio standards of the reciprocal state.



AUTHORITY NOTE: Promulgated in accordance with R.S. 23:381-391.

HISTORICAL NOTE: Promulgated by the Department of Labor, Office of Labor, LR 12:429 (July 1986), amended LR 17:356 (April 1991), amended by the Louisiana Workforce Commission, Office of Workforce Development, LR 37:2211 (July 2011).

### §303. Apprenticeship Agreements

A. The apprenticeship agreement form will be supplied by the director of apprenticeship to apprenticeship committees and to individual establishments interested in apprenticeship.

B. Pre-Apprentices. For the purposes of apprenticeship, the Louisiana Workforce Commission, Apprenticeship Division will not indenture pre-apprentices. However, if an organization wishes to establish a bona fide pre-apprenticeship training program, it must make written request to the Apprenticeship Division and demonstrate strong linkages between it and a registered apprenticeship program(s) within Louisiana. If appropriate, the director of apprenticeship may issue a letter of recognition.

C. The date of an apprenticeship agreement will be the actual date the apprentice entered employment as an apprentice as agreed to by the employer, the apprentice, and approved by the Louisiana Workforce Commission, Apprenticeship Division.

D. Apprenticeship agreements to be submitted and processed as follows:

1. program sponsor and apprentice both complete and sign the agreement;
2. program sponsor retains original on file and enters apprentice agreement into the Registered Apprenticeship Partners Information Data System (RAPIDS) to submit electronic request for approval by the director of apprenticeship within 45 days of the apprentice's first day of employment;
3. a copy for the apprentice shall be provided; and
4. director of apprenticeship shall approve or deny, as appropriate, apprentice registration related requests through RAPIDS within 45 days of receipt, and the program sponsor will be notified of any action taken in RAPIDS via email immediately thereafter.

D. Every apprenticeship agreement entered into shall be signed by the contracting parties (apprentice, and the program sponsor or employer), and the signature of a parent or guardian if the apprentice is a minor employer.

E. Where a trade is covered by a city, parish or state license law or ordinance requiring the journeyworker or skilled worker to produce a license to follow the trade, it will be necessary that this provision of the law be observed before an apprentice employed in such establishment can be registered.

F. Every apprenticeship agreement entered into under the provisions of the Louisiana Apprenticeship Law shall contain:

1. the names of the contacting parties;
2. the date of birth of the apprentice;
3. social security number, on a voluntary basis;
4. a statement of the trade or craft in which the apprentice is to be taught, and the time at which the apprenticeship will begin and end;
5. the number of hours to be spent by the apprentice in work on the job in a time-based program; or a description of the skill sets to be attained by completion of a competency-based program, including the on-the-job learning component; or the minimum number of hours to be spent by the apprentice and a description of the skill sets to be attained by completion of hybrid program; and
6. a statement setting forth a schedule of the work processes in the trade or industry divisions in which the apprentice is to be trained and the approximate time to be spent at each process;
7. the number of hours to be spent in related instruction in technical subjects related to the occupation, which shall not be not less than 144 hours per year;
8. a statement of the graduated scale of wages to be paid the apprentice;
9. a statement providing for a period of probation of not more than 25 percent of the term of apprenticeship or one year, whichever is shorter in duration, during which time the apprenticeship agreement may be terminated, without adverse impact on the program sponsor, by the director of apprenticeship at the request, through RAPIDS, by the program sponsor, or in writing by the apprentice, providing that after such probationary period the apprenticeship agreement may be terminated by the director of apprenticeship by mutual agreement of all parties thereto, or canceled by the director of apprenticeship for good and sufficient reason;
10. a provision that all controversies or differences concerning the apprenticeship agreement which cannot be adjusted locally in accordance with R.S. 23:385 shall be submitted to the director or apprenticeship for determination, as provided in R.S. 23:390;
11. a statement providing after the probationary period, the agreement may be:
  - a. cancelled at the request of the apprentice; or
  - b. suspended or cancelled by the sponsor, for good cause, with due notice to the apprentice and a reasonable opportunity for corrective action, and with written notice to the apprentice and to the registration agency within 45 days of the final action taken;
12. such additional terms and conditions as may be prescribed or approved by the director, not inconsistent with the provisions of this Chapter and those established by the Office of Apprenticeship, United States Department of Labor;

13. a reference incorporating as part of the agreement the standards of the apprenticeship program as it exists on the date of the agreement and as it may be amended during the period of the agreement; and

14. a statement that the apprentice will be accorded equal opportunity in all phases of apprenticeship employment and training, without discrimination because of race, color, religion, national origin or sex;

15. any proposed change in the terms of a registered apprenticeship agreement must be submitted to the Apprenticeship Division for approval by the director of apprenticeship;

16. wages of the apprentice will vary with the occupation and locality. The agreement shall contain a statement of the graduated scale of wages to be paid the apprentice (and whether or not the required school time shall be compensated). When the graduated wage rate of the apprenticeship is set on a six month basis, in no instance shall the increase each six months be less than 5 percent. When the wage increase is set on a yearly basis, in no instance shall the increase be less than 10 percent each year. Provided, however, that a program that has at least a minimum starting wage rate of 45 percent of the journeyworker hourly wage rate and has reached 75 percent of the journeyworker hourly wage rate in the final period will be acceptable. The starting wage rate of an apprentice shall not be less than 45 percent of the journeyworker hourly wage or less than the applicable state/federal minimum wage. In no case shall the final period of apprenticeship be less than 75 percent of the journeyworker hourly wage in a four-year trade classification.

G. Such additional terms and conditions as may be prescribed or approved by the director, not inconsistent with the provisions of this Chapter and those established by the Office of Apprenticeship, United States Department of Labor in accordance with 29 CFR Part 29/30.

AUTHORITY NOTE: Promulgated in accordance with R.S. 23:381-391.

HISTORICAL NOTE: Promulgated by the Department of Labor, Office of Labor, LR 12:430 (July 1986), amended LR 17:356 (April 1991), amended by the Louisiana Workforce Commission, Office of Workforce Development, LR 37:2213 (July 2011).

### **§305. Procedure for Approval of Apprenticeship Agreements**

A. The director of apprenticeship shall approve an apprenticeship agreement within 15 days if:

1. it meets the standards established under the Louisiana Apprenticeship Law and these rules for an apprenticeship program which has been properly registered with the Louisiana Workforce Commission, Apprenticeship Division;

2. the agreement contains all the requisites provided in §303.

AUTHORITY NOTE: Promulgated in accordance with R.S. 23:381-391.

HISTORICAL NOTE: Promulgated by the Department of Labor, Office of Labor, LR 12:431 (July 1986), amended LR 17:356 (April 1991), amended by the Louisiana Workforce Commission, Office of Workforce Development, LR 37:2214 (July 2011).

### **§307. Procedure for the Cancellation or Termination of Apprenticeship Agreements and Issuance of Interim Credentials and Certificates of Completion**

A. The director of apprenticeship may terminate or cancel any apprenticeship agreement in accordance with the provisions of that agreement.

B. In the event that an agreement is terminated by mutual consent of all parties thereto, no opportunity for a hearing prior to such termination is required.

C. Prior to the cancellation or termination of an agreement for reasons other than mutual agreement of all parties, the parties to such agreement shall be afforded an opportunity for hearing after reasonable notice. Such notice and hearing shall conform to the requirements of the Administrative Procedure Act, R.S. 49:955.

D. Programs that adopt competency or hybrid structured standards of apprenticeship may request interim credentials for certification of competency attainments made by an apprentice from the Office of Apprenticeship, United States Department of Labor.

E. Upon the satisfactory completion of apprenticeship, the director of apprenticeship shall issue a certificate of completion of apprenticeship showing the trade in which apprenticeship was served, the date of completion and the name of the program sponsor. A completion certificate shall be issued only after the director of apprenticeship has received an electronic request through the Registered Apprenticeship Partners Information Data System (RAPIDS) for such completion certificate, signed by a representative of the pertinent program sponsor, which signature shall certify that the required training and related instruction has been completed, or after the apprentice has furnished to the director of apprenticeship documented evidence which proves that the required training and related instruction has been completed. If there exists extenuating circumstances in which the program sponsor is unable to access RAPIDS, a written request will be accepted.

AUTHORITY NOTE: Promulgated in accordance with R.S. 23:381-391. HISTORICAL NOTE: Promulgated by the Department of Labor, Office of Labor, LR 12:431 (July 1986), amended LR 17:356 (April 1991), amended by the Louisiana Workforce Commission, Office of Workforce Development, LR 37:2214 (July 2011).

### **§309. Settlement of Controversies or Complaints, Deregistration Proceedings**

A. The director of apprenticeship is empowered to investigate possible violations of the terms of an apprenticeship agreement and the standards of apprenticeship that govern such agreements. Such investigation may be based upon the complaint of an interested person, reasonable cause, a request from the state

apprenticeship council upon a majority vote, or upon the initiative of the director of apprenticeship. The director of apprenticeship is further empowered to hold hearings, inquiries and other proceedings necessary to such investigations and determinations. Prior to any determination concerning a possible violation of the terms of an apprenticeship agreement or the governing standards of apprenticeship, the director of apprenticeship shall conduct a fact finding.

B. Subsequent to a determination, the director of apprenticeship shall make notification to the state apprenticeship council, and file a fact finding including recommended penalties not resulting in deregistration, with the executive director. If no appeal there from is filed with the executive director within 10 days after the date thereof, such determination shall become the order of the director of apprenticeship.

C. Any person aggrieved by a determination or action of the director of apprenticeship may appeal such action to the executive director who shall hold a hearing thereon, after due notice to the interested parties. Such hearing shall conform to the requirements of the Administrative Procedure Act, R.S. 49:955.

#### D. Deregistration

1. Deregistration of a program may be effected upon the voluntary action of the sponsor by submitting a request for cancellation in writing to the director of apprenticeship, or upon reasonable cause, by the director of apprenticeship instituting formal deregistration proceedings in accordance with this Section.

2. Deregistration at the Request of the Sponsor. The director of apprenticeship may cancel the registration of an apprenticeship program by written acknowledgment of such request stating the following:

a. the registration is cancelled at the sponsor's request, and the effective date thereof;

b. that, within 15 days of the date of the acknowledgment, the sponsor will notify all apprentices of such cancellation and the effective date; that such cancellation automatically deprives the apprentice of individual registration; that the deregistration of the program removes the apprentice from coverage for federal purposes which require the secretary of Labor's approval of an apprenticeship program, and that all apprentices are referred to the Louisiana Workforce Commission, Apprenticeship Division for information about potential transfer to other registered apprenticeship programs.

#### 3. Deregistration upon Reasonable Cause

a. Deregistration proceedings may be undertaken when the apprenticeship program is not conducted, operated, or administered in accordance with the program's registered provisions or with the requirements of this part, including but not limited to: failure to provide on-the-job learning; failure to provide related instruction; failure to pay the apprentice a progressively increasing schedule of wages

consistent with the apprentices skills acquired; or persistent and significant failure to perform successfully. Deregistration proceedings for violation of equal opportunity requirements must be processed in accordance with the provisions under 29 CFR Part 30 and Title 40, Chapter 5.

b. For purposes of this Section, persistent and significant failure to perform successfully occurs when a program sponsor consistently fails to register at least one apprentice, shows a pattern of poor quality assessment results over a period of several years, demonstrates an ongoing pattern of very low completion rates over a period of several years, or shows no indication of improvement in the areas identified by the Apprenticeship Division during a review process as requiring corrective action.

c. Where it appears the program is not being operated in accordance with the registered standards or with requirements of this Part, the Apprenticeship Division must notify the program sponsor in writing.

d. The notice sent to the program sponsor's contact person must:

i. be sent by registered or certified mail, with return receipt requested;

ii. state the shortcoming(s) and the remedy required; and

iii. state that a determination of reasonable cause for deregistration will be made unless corrective action is effected within 30 days.

e. Upon request by the sponsor for good cause, the 30-day term may be extended for another 30 days. During the period for corrective action, the Apprenticeship Division shall assist the sponsor in every reasonable way to achieve conformity.

f. If the required correction is not effected within the allotted time, the Apprenticeship Division must send a notice to the sponsor, by registered or certified mail, return receipt requested, stating the following:

i. the notice is sent under this Paragraph;

ii. certain deficiencies were called to the sponsor's attention (enumerating them and the remedial measures requested, with the dates of such occasions and letters), and that the sponsor has failed or refused to effect correction;

iii. based upon the stated deficiencies and failure to remedy them, a determination has been made that there is reasonable cause to deregister the program and the program may be deregistered unless, within 15 days of the receipt of this notice, the sponsor requests a hearing with the applicable Apprenticeship Division; and

iv. if the sponsor does not request a hearing, the entire matter will be submitted to the Administrator, Office of Apprenticeship, for a decision on the record with respect to deregistration.

g. If the sponsor does not request a hearing, the Apprenticeship Division will transmit to the administrator a report containing all pertinent facts and circumstances concerning the non-conformity, including the findings and recommendation for deregistration, and copies of all relevant documents and records. Statements concerning interviews, meetings and conferences will include the time, date, place, and persons present. The administrator will make a final order on the basis of the record presented.

h. If the sponsor requests a hearing, the Apprenticeship Division will follow the grievance procedures outlined in Subsection C of this Section and refer the matter to the executive director.

i. If, based upon the evidence and testimony presented, the executive director upholds the determination of the director of apprenticeship, the decision shall be conclusive if no appeal there from is filed within 30 days after the date of the order or decision. The sponsor has the right to further appeal the decision to the administrator, Office of Apprenticeship. The Apprenticeship Division will transmit to the administrator a report containing all the data listed in Subparagraph D.3.g of this Section, and the administrator will refer the matter to the Office of Administrative Law Judges. An administrative law judge will convene a hearing in accordance with 29 CFR §29.10, and issue a decision as required in 29 CFR §29.10(c).

4. Every order of deregistration must contain a provision that the sponsor must, within 15 days of the effective date of the order, notify all registered apprentices of the deregistration of the program; the effective date thereof; that such cancellation automatically deprives the apprentice of individual registration; that the deregistration removes the apprentice from coverage for state and federal purposes which require the director of apprenticeship's approval of an apprenticeship program; and that all apprentices are referred to the Apprenticeship Division for information about potential transfer to other registered apprenticeship programs.

5. Reinstatement of Program Registration. Any apprenticeship program deregistered under this Section and 29 CFR §29.8 may be reinstated upon presentation of adequate evidence that the apprenticeship program is operating in accordance with this Part. Such evidence must be presented to the Louisiana Workforce Commission, Apprenticeship Division for consideration.

6. No person shall institute any action for the enforcement of any apprenticeship agreement, or for damages for the breach thereof unless all administrative remedies provided in these rules have first been exhausted.

AUTHORITY NOTE: Promulgated in accordance with R.S. 23:381-391.

HISTORICAL NOTE: Promulgated by the Department of Labor, Office of Labor, LR 12:431 (July 1986), amended LR 17:356 (April 1991), amended by the Louisiana Workforce Commission, Office of Workforce Development, LR 37:2214 (July 2011).

## §311. Civil Penalties

### A. Provisions

1. Any person, including but not limited to, any apprenticeship program sponsor or employer of a registered apprentice, shall be subject to a civil penalty of up to five hundred dollars per violation of the provisions of any of the following:

- a. Title 40, Part IX;
- b. approved program standards;
- c. an approved apprenticeship agreement;
- d. any rules or regulations governing apprenticeship adopted pursuant to the authority contained within Title 40, Part IX of the *Louisiana Administrative Code*.

2. Reasonable litigation expenses may be awarded to the prevailing party of the adjudicatory hearing. *Reasonable litigation expenses* means any expenses, not exceeding \$7,500, reasonably incurred in prosecuting, opposing, or contesting an agency action, including but not limited to attorney fees, stenographer fees, investigative fees and expenses, witness fees and expenses, and administrative costs.

B. Civil penalties may be imposed only by a ruling of the executive director or his designee, in accordance with §309 of this Part.

C. Out of the civil penalties collected for violations, expenses incurred in enforcing any provisions may be paid by the commission.

D. The executive director may institute civil proceedings in the appropriate district court for the principal place of business of the employer to enforce his rulings or seek injunctive relief to restrain and prevent violations of the provisions of this Chapter or of the rules and regulations adopted under the provisions of this Chapter. The court shall award attorney fees and court costs to the prevailing party. In the event judgment is rendered in said court affirming the civil penalties assessed, the court shall also award to the Louisiana Workforce Commission, Apprenticeship Division judicial interest on said penalties from the date of such judgment until paid.

AUTHORITY NOTE: Promulgated in accordance with R.S. 23:381-391.

HISTORICAL NOTE: Promulgated by the Department of Labor, Louisiana Workforce Commission, Office of Workforce Development, LR 37:2216 (July 2011).

## §313. Cooperation with Other Organizations

A. Louisiana Workforce Commission Business and Career Solution Centers shall:

1. assist in the recruiting and placement of apprentices as appropriate ; and
2. advise job seekers of the registered apprenticeship opportunities in their region and their minimum entrance requirements.

B. Louisiana Community and Technical College System shall:

1. supply related training to apprentice classes, and shall furnish classrooms, aids, technical equipment, and other such training materials necessary to the proper training of the apprentices;
2. supervise the related training of apprentices;
3. advise youth as to the entrance requirements of apprenticeship training; and
4. advise employers as to the advantages of apprentice training.

AUTHORITY NOTE: Promulgated in accordance with R.S. 23:381-391.

HISTORICAL NOTE: Promulgated by the Department of Labor, Office of Labor, LR 12:432 (July 1986), amended LR 17:356 (April 1991), amended by the Louisiana Workforce Commission, Office of Workforce Development, LR 37:2216 (July 2011).

**§315. Limitations**

A. In accordance with Act 364 of 1938, Section 391, nothing in this Chapter or in any apprentice agreement approved under this Chapter shall operate to invalidate any apprenticeship provision in any collective agreement between employers and employees.

AUTHORITY NOTE: Promulgated in accordance with R.S. 23:381-391.

HISTORICAL NOTE: Promulgated by the Department of Labor, Office of Labor, LR 12:432 (July 1986), amended LR 17:356 (April 1991), amended by the Louisiana Workforce Commission, Office of Workforce Development, LR 37:2216 (July 2011).

**§317. Criteria for Apprenticeable Occupations**

A. An apprenticeable occupation is a skilled trade which possesses all of the following characteristics.

1. It is customarily learned in a practical way through a structured, systematic program of on-the-job supervised training.
2. It is clearly identified and commonly recognized throughout an industry.
3. It involves manual, mechanical or technical skills and knowledge which require a minimum of 2,000 hours of on- the-job work experience.
4. It requires related instruction to supplement the on-the-job training.
5. It has been approved by the United States Department of Labor as an apprenticeable occupation.
6. In instances when an employer proposes the development of an apprenticeship program for an occupation that is not found on the federal apprenticeable occupations list, the employer shall provide evidence that:

a. the occupation is considered “high demand” according to Louisiana labor market information;

b. the occupation represents an emerging demand industry-wide;

c. the occupation meets all other criteria for an apprenticeable occupation;

d. an application has been submitted to the United States Department of Labor for the occupation to be recognized as apprenticeable.

AUTHORITY NOTE: Promulgated in accordance with R.S. 23:381-391.

HISTORICAL NOTE: Promulgated by the Department of Labor, Office of Labor, LR 12:432 (July 1986), amended LR 17:356 (April 1991), amended by the Louisiana Workforce Commission, Office of Workforce Development, LR 37:2216 (July 2011).

**Chapter 5. Louisiana State Plan for Equal Opportunity in Apprenticeship**

**§501. Scope and Purpose**

A. This plan sets forth policies and procedures to promote equality of opportunity in apprenticeship programs registered with the Louisiana Workforce Commission, Apprenticeship Division. These policies and procedures apply to the recruitment and selection of apprentices, and to all conditions of employment and training during apprenticeship. The procedures established provide for review of apprenticeship programs, for registering apprenticeship programs, for processing complaints and for deregistering non-complying apprenticeship programs.

B. The purpose of this plan is to promote equality of opportunity in apprenticeship by prohibiting discrimination based on race, color, religion, national origin, or sex in apprenticeship programs, by requiring affirmative action to provide equal opportunity in such apprenticeship programs, and by coordinating this plan with other equal opportunity programs.

AUTHORITY NOTE: Promulgated in accordance with R.S. 23:381-391.

HISTORICAL NOTE: Promulgated by the Department of Labor, Office of Labor, LR 12:433 (July 1986), amended LR 17:356 (April 1991), amended by the Louisiana Workforce Commission, Office of Workforce Development, LR 37:2217 (July 2011).

**§503. Definitions**

*Commission*—the Louisiana Workforce Commission.

*Employer*—any person or organization employing an apprentice whether or not the apprentice is enrolled with such person or organization or with some other person or organization as an employer.

*Executive Director*—the executive head and chief administrative officer of the Louisiana Workforce Commission, or any person specifically designated by the executive director.

*Louisiana Workforce Commission, Apprenticeship Division*—the division within Louisiana state government that is recognized by the Office of Apprenticeship, United

States Department of Labor as the official state apprenticeship agency of record for registration of apprenticeship programs for federal purposes.

*Sponsor*—any person or organization operating a state apprenticeship program, irrespective of whether such person or organization is an employer as a sponsor.

*State Apprenticeship Council (SAC)*—the Louisiana State Apprenticeship Council, serving as the advisory board to the Louisiana Workforce Commission.

*State Apprenticeship Program*—a program registered with the Louisiana Workforce Commission, Apprenticeship Division and meeting the minimum standards of the applicable federal and state apprenticeship laws.

**AUTHORITY NOTE:** Promulgated in accordance with R.S. 23:381-391.

**HISTORICAL NOTE:** Promulgated by the Department of Labor, Office of Labor, LR 12:433 (July 1986), amended LR 17:356 (April 1991), amended by the Louisiana Workforce Commission, Office of Workforce Development, LR 37:2217 (July 2011).

### **§505. Authority**

A. Under the authority vested in the Louisiana Workforce Commission, Apprenticeship Division and set out in Louisiana Revised Statutes, 1950, (annotated) as amended, R.S. 23:381 through R.S. 23:391, a policy is hereby formulated for non-discrimination in apprenticeship and training by the Louisiana Workforce Commission, Apprenticeship Division.

B. On May 12, 1978, a revised Title 29 CFR Part 30 was established at the request of the Office of the Secretary of Labor, U.S. Department of Labor. Section 30.15, "State Agencies," of Title 29, Part 30, encourages all state apprenticeship agencies to adopt and implement the standards of the U.S. Department of Labor policy.

**AUTHORITY NOTE:** Promulgated in accordance with R.S. 23:381-391.

**HISTORICAL NOTE:** Promulgated by the Department of Labor, Office of Labor, LR 12:433 (July 1986), amended LR 17:356 (April 1991), amended by the Louisiana Workforce Commission, Office of Workforce Development, LR 37:2217 (July 2011).

### **§507. Equal Opportunity Standards**

A. **Obligation of Sponsor.** Each sponsor of an apprenticeship program shall:

1. recruit, select, employ and train apprentices during their term of apprenticeship without discrimination because of race, color, religion, national origin, or sex;

2. uniformly apply rules and regulations concerning apprentices, including but not limited to equality of wages, periodic advancement, promotion, assignment of work, job performance, rotation among all work processes of the trade, imposition of penalties or other disciplinary action, and all other aspects of the apprenticeship program administration by the program sponsor; and

3. take affirmative action to provide equal opportunity in apprenticeship, including adoption of an affirmative action plan as required by this state plan.

B. **Equal Opportunity Pledge.** Each sponsor of an apprenticeship program shall include in its standards the following equal opportunity pledge:

"The recruitment, selection, employment, and training of apprentices during their apprenticeship, shall be without discrimination because of race, color, religion, national origin, or sex. The sponsor will take affirmative action to provide equal opportunity in apprenticeship and will operate the apprenticeship program as required under Title 29 of Code of Federal Regulations, Part 30, and the Louisiana State Plan."

C. **Programs Presently Registered.** Each sponsor of a program registered with the council as of the effective date of this Part shall within 90 days of that effective date take the following action:

1. include in the standards of its apprenticeship program the equal opportunity pledge prescribed by §507.B;

2. adopt an affirmative action plan as required by §509; and

3. adopt a selection procedure as required by §511 of this plan. A sponsor adopting a selection method as described under §511.B.2, 3, or 4 shall prepare, and have available for submission upon request copies of its amended standards, affirmative action plans, and selection procedure. A sponsor adopting a selection method as described under §511.B.5 shall submit to the council copies of its standards, affirmative action plan, and selection procedure in accordance with the requirements of §511.B.5.

D. **Sponsors Seeking New Registration.** A sponsor of a program seeking new registration with the apprenticeship division shall submit copies of its proposed standards, affirmative action plan, selection procedures, and such other information as may be required. The program shall be registered if such standards, affirmative action plan, and selection procedure meet the requirements of this plan.

E. **Programs Subject to the Approved Equal Employment Opportunity Plans.** A sponsor shall not be required to adopt an affirmative action plan described under §509 of this plan or a selection procedure described under §511 if it submits to the Apprenticeship Division and State Apprenticeship Council satisfactory evidence that it is in compliance with an equivalent equal employment opportunity program. This program must provide for affirmative action in apprenticeship including goals and timetables for women and minorities and must be approved as meeting the requirements of Title VII of the Civil Rights Act of 1964, as amended (42 U.S.C. 2000e et seq.) and its implementing regulations published in Title 29 of the Code of Federal Regulations, Chapter, XIV, or Executive Order 11246, as amended and its implementing regulations at Title 41 of the Code of Federal Regulations, Chapter 60 provided, that programs approved, modified, or renewed subsequent to the effective date of this amendment will qualify for this exception only if the goals and timetables for the selection of minority and female apprentices provided for in such

programs are equal to or greater than the goals required under this Subsection.

F. Program with Fewer than Five Apprentices. A sponsor of a program in which fewer than five apprentices are indentured shall not be required to adopt an affirmative action plan under §509 of this plan or a selection procedure under §511, provided that such program was not adopted to circumvent the requirements of this Subsection.

AUTHORITY NOTE: Promulgated in accordance with R.S. 23:381-391.

HISTORICAL NOTE: Promulgated by the Department of Labor, Office of Labor, LR 12:433 (July 1986), amended LR 17:356 (April 1991), amended by the Louisiana Workforce Commission, Office of Workforce Development, LR 37:2217 (July 2011).

### **§509. Affirmative Action Plans**

A. Adoption of Affirmative Action Plans. A sponsor's commitment to equal opportunity in recruitment, selection, employment, and training of apprentices shall include the adoption of a written affirmative action plan.

B. Definition of Affirmative Action. Affirmative action is not merely passive nondiscrimination. It includes procedures, methods, and programs for the identification, positive recruitment, training, and motivation of present and potential minority and female (minority and nonminority) apprentices, including the establishment of goals and timetables. It is action which will equalize opportunity in apprenticeship so as to allow full utilization of the work potential of minorities and women. The overall result to be sought is equal opportunity in apprenticeship for all individuals participating in or seeking entrance to the nation's labor force.

C. Outreach and Positive Recruitment. An acceptable affirmative action plan must also include adequate provision for outreach and positive recruitment that would reasonably be expected to increase minority and female participation in apprenticeship by expanding the opportunity of minorities and women to become eligible for apprentice selection. The affirmative action plan shall set forth the specific steps the sponsor intends to take in the areas listed below in order to achieve these objectives.

1. Disseminate Information Concerning the Nature of Apprenticeship, Availability of Apprenticeship Opportunities, Source of Apprenticeship Applicants, and the Equal Opportunity Policy of the Sponsor. For programs accepting applications only at specified intervals, such information shall be disseminated at least 30 days in advance of the earliest date for applications at each interval. For programs customarily receiving applications throughout the year, such information shall be regularly disseminated but not less than semi-annually. Such information shall be given to the apprenticeship division, U.S. Department of Labor, local schools, employment service offices, women's centers, outreach programs, and community organizations which can effectively reach minority groups and women, and published in newspapers which are circulated in the minority

community and among women, as well as the general areas in which the program sponsor operates.

2. Participate in annual workshops conducted by employment service agencies for the purpose of familiarizing school, employment service, and other appropriate personnel with the apprenticeship system and current opportunities therein.

3. Cooperate with local school boards and vocational education systems to develop programs for preparing students to meet the standards and criteria required to qualify for entry into apprenticeship programs.

4. Provide internal communication of the sponsor's equal opportunity policy in such a manner as to foster understanding, acceptance, and support among the sponsor's various officers, supervisors, employees, and members, and to encourage such persons to take necessary action to aid the sponsor in meeting its obligations under this plan.

5. Engage in programs such as Outreach for the positive recruitment and preparation of potential applicants for apprenticeship; where appropriate and feasible, such programs shall provide for pre-testing experience and training. If no such programs are in existence, the sponsor shall seek to initiate these programs, or, when available, to obtain financial assistance from the U.S. Department of Labor. In initiating and conducting these programs, the sponsor may be required to work with other sponsors and appropriate community organizations. The sponsor also shall initiate programs to prepare women to enter traditionally male programs.

6. Encourage establishment and use of programs of preapprenticeship, preparatory trade training, or other programs designed to afford related work experience or to prepare candidates for apprenticeship. A sponsor shall make appropriate provision in its affirmative action plan to assure that those who complete such programs are afforded full and equal opportunity for admission into the apprenticeship program.

7. Utilize journeypersons to assist in the implementation of the sponsor's affirmative action program.

8. Grant advanced standing or credit on the basis of previously acquired experience, training, skills, or aptitude for all applicants equally.

9. Admit to apprenticeship persons whose age exceeds the maximum age for admission to the program, where such action assists the sponsor in achieving its affirmative action obligations.

10. Take any other action necessary to ensure that recruitment, selection, employment, and training of apprentices during apprenticeship, shall be without discrimination because of race, color, religion, national origin, or sex, such as general publication of apprenticeship opportunities and advantages in advertisements, industry reports, articles, etc.; use of present minority and female apprentices and journeypersons as recruiters; career counseling; periodic auditing of affirmative action programs

and activities; and development of reasonable procedures between sponsors and employers of apprentices to ensure that equal employment opportunity is being granted including reporting systems, on-site reviews, briefing sessions, etc.

#### D. Goals and Timetables

1. A sponsor adopting a selection method under §511.B.2 or 3 of this plan which determines on the basis of the analysis described in §509.E that it has deficiencies in terms of underutilization of minorities and/or women (minority and nonminority) in craft or crafts represented by the program shall include in its affirmative action plan percentage goals and timetables for admission of minorities and/or female (minority and non-minority) applicants into the eligibility pool.

2. A sponsor adopting a selection method under §511.B.4 or 5 which determines on the basis of the analysis described in Subsection E of this Section that it has deficiencies in terms of underutilization of minorities and/or women in craft or crafts represented by the program shall include in its affirmative action plan percentage goals and timetables for selecting minority and female (minority and nonminority) applicants for the apprenticeship program.

#### E. Underutilization

1. As used in this Paragraph, underutilization refers to a condition in which fewer minorities and/or women (minority and nonminority) are employed in the particular craft or crafts represented by the program than would be reasonably expected in view of an analysis of specific factors in §509.F.1-5 of this plan.

2. When, on the basis of the analysis, the sponsor determines that it has no deficiencies, no goals and timetables need be established. However, where no goals and timetables are established, the affirmative action plan shall include a detailed explanation why no goals and timetables have been established.

3. When the sponsor fails to submit goals and timetables as part of its affirmative action plan or submits goals and timetables which are unacceptable, and the council determines that the sponsor has deficiencies in terms of underutilization of minorities or women (minority and nonminority) within the meaning of this Paragraph, the council shall establish goals and timetables applicable to the sponsor for admission of minority and female (minority and non-minority) applicants into the eligibility pool or selection of apprentices, as appropriate. The sponsor shall make good faith efforts to attain these goals and timetables in accordance with all requirements of this Paragraph.

F. Analysis to Determine if Deficiencies Exist. This analysis shall be set forth in writing of the affirmative action plan. The sponsor's determination as to whether goals and timetables shall be established, shall be based on an analysis of at least the following factors:

1. the size of the working age minority and female (minority and nonminority) population in the program sponsor's labor market area;

2. the size of the minority and female (minority and non-minority) labor force in the program sponsor's labor market area;

3. the percentage of minority and female (minority and non-minority) participation as apprentices in the particular craft as compared with the percentage of minorities and women in the labor force in the program sponsor's labor market area;

4. the percentage of minority and female (minority and non-minority) participation as journeypersons employed by the employer or employers participating in the program as compared with the percentage of minorities and women (minority and non-minority) in the sponsor's labor market area and the extent to which the sponsor should be expected to correct any deficiencies through the achievement of goals and timetables for the selection of apprentices; and

5. the general availability of minorities and women (minority and non-minority) with present or potential capacity for apprenticeship in the program sponsor's labor market area.

G. Establishment and Attainment of Goals and Timetables. Goals and timetables shall be established on the basis of the sponsor's analyses of its underutilization of minorities and women and its entire affirmative action program. A single goal for minorities and a separate single goal for women is acceptable unless a particular group is employed in a substantially disparate manner in which case separate goals shall be established for such group. Such separate goals would be required, for example, if a specific minority group of women were underutilized even though the sponsor had achieved its standards for women generally. In establishing goals, the sponsor should consider results which could be reasonably expected from its good-faith efforts to make its overall affirmative action program work. Compliance with these requirements shall be determined by whether the sponsor has met its goals within its timetables, or failing that, whether it has made good faith efforts to meet its goals and timetables. Its good faith efforts shall be judged by whether it is following its affirmative action program and attempting to make it work, including evaluation and changes in its program where necessary to obtain maximum effectiveness toward attainment of its goals. However, in order to deal fairly with program sponsors, and with women who are entitled to protection under goals and timetables requirements, during the first 12 months after the effective date of these regulations, the program sponsor would generally be expected to set a goal for women for the entering year class at a rate which is not less than 50 percent of the proportion women represent in the workforce in the program sponsor's labor market area, and set a percentage goal for women in each class beyond the entering class which is not less than the participation rate of women currently in the preceding class. At the end of the first 12 months after the effective date of these regulations, sponsors



are expected to make appropriate adjustments in goal levels. See §515.B.

H. Data and Information. The director of apprenticeship shall make available to program sponsors data and information on minority and female (minority and nonminority) labor force characteristics for each standard metropolitan statistical area, and for other special areas as appropriate.

AUTHORITY NOTE: Promulgated in accordance with R.S. 23:381-391.

HISTORICAL NOTE: Promulgated by the Department of Labor, Office of Labor, LR 12:433 (July 1986), amended LR 17:356 (April 1991), amended by the Louisiana Workforce Commission, Office of Workforce Development, LR 37:2218 (July 2011).

### §511. Selection of Apprentices

A. Obligations of Sponsors. In addition to development of a written affirmative action plan to ensure that minorities have an equal opportunity for selection as apprentices and otherwise ensure prompt achievement of full and equal opportunity in apprenticeship, each sponsor shall further provide in its affirmative action program that selection of apprentices shall be made under one of the methods specified in Paragraphs B.2-5 of this Section.

B. Selection. The requirements set forth in this Paragraph B.1 of this Section shall apply to all the methods specified in Paragraphs B.2-5 of this Section.

1. Creation of Pool of Eligibles. A pool of eligibles shall be created from applicants who meet the qualification of minimum legal working age or from applicants who meet qualification standards in addition to minimum legal age and provided that any additional qualification standards conform with the following requirements.

a. Qualification Standards. Qualification standards, and procedures for determining such qualification standards, shall be stated in detail and shall provide criteria for the specific factors and attributes which are to be considered in evaluating applicants for admission to the pool. The score required under each qualification standard for admission to the pool also shall be specified. All qualification standards, and the score required on any standard for admission to the pool, shall be directly related to job performance, as shown by a significant statistical relationship the score required for admission to the pool, and performance in the apprenticeship program. In demonstrating such relationships, the sponsor shall follow procedures set forth in the Guidelines on Employee Selection Procedures, published at 41 CFR Part 60-3. Qualifications shall be considered as separately required so that failure of an applicant to attain the specified score under a single qualification standard shall disqualify the applicant from admission to the pool.

b. Aptitude Tests. Any qualification standard for admission to the pool consisting of aptitude test scores shall be directly related to job performance, as shown by significant statistical relationships between the score on the aptitude tests required for admission to the pool, and performance in the apprenticeship program. In determining

such relationships, the sponsor shall follow the procedures set forth in 41 CFR Part 60-3. The requirements of this Subparagraph also shall be applicable to aptitude tests used by a program sponsor which are administered by a state employment service agency, a private employment agency, or any other person, agency, or organization engaged in selection or evaluation of personnel. A national test developed and administered by a national joint apprenticeship committee will not be approved by the council unless the test meets the requirements of this Part.

c. Educational Attainments. All educational attainments or achievements as qualifications for admission to the pool shall be directly related to job performance, as shown by a significant statistical relationship between the score required for admission to the pool, and performance, in the apprenticeship program. In demonstrating such relationships, the sponsor shall meet the requirements of 41 CFR Part 60-3. School records or a passing grade on the general education development tests recognized by the state or local public instruction authority shall be evidence of educational achievement. Education requirements shall be applied uniformly to all applicants.

d. Oral Interviews. Oral interviews shall not be used as a qualification standard for admission into an eligibility pool. However, once an applicant is placed in the eligibility pool, and before he or she is selected for apprenticeship from the pool, he or she may be required to submit to an oral interview. Oral interviews shall be limited only to such objective questions as may be required to determine fitness of applicants to enter the apprenticeship program, but shall not include questions relating to qualifications previously determined in gaining entrance to the eligibility pool. When an oral interview is used, each interviewer shall record the questions and the general nature of the applicant's answers, and shall prepare a summary of any conclusions. Each applicant rejected from the pool of eligibles on the basis of an oral interview shall be given a written statement of such rejection, reasons therefore, and appeal rights available to the applicant.

e. Notification of Applicants. All applicants who meet requirements for admission shall be notified and placed in the eligibility pool. The program sponsor shall give each applicant from the applicant pool notice of his or her rejection, including reasons for the rejection, requirements for admission to the pool of eligibles, and appeal rights available to the applicant.

f. Goals and Timetables. The sponsor shall establish, where required by §509.D, percentage goals and timetables for admission of minorities and women (minority and nonminority) into the pool of eligibles in accordance with provisions of §509.D, E, and F.

g. Compliance. A sponsor shall be deemed to be in compliance with its commitment under §511.B.1.f of this plan if it meets its goals or timetables or if it makes a good faith effort to meet these goals and timetables. In the event of failure of the sponsor to meet its goals and timetables, it shall be given an opportunity to demonstrate that it has made

every good-faith effort to meet its commitments (refer to §509.F). All the actions of the sponsor shall be reviewed and evaluated in determining whether such good-faith efforts have been made.

2. Selection on Basis of Rank from a Pool of Eligible Applicants. A sponsor may select apprentices from a pool of eligible applicants created in accordance with requirements for §511.B.1 on the basis of rank order of scores of applicants on one or more qualification standards, where there is a significant statistical relationship between rank order of scores and performance in the apprenticeship program. In demonstrating such relationship, the sponsor shall follow procedures set forth in 41 CFR Part 60-3.

### 3. Random Selection from Pool of Eligible Applicants

a. Selection. A sponsor may select apprentices from a pool of eligible applicants on a random basis. The method of random selection is subject to approval by the council. Supervision of the random selection process shall be by an impartial person or persons selected by the sponsor, but not associated with the administration of the apprenticeship program. The time and place of the selection, and the number of apprentices to be selected, shall be announced. The place of selection shall be open to all applicants and the public. The names of apprentices drawn by this method shall be posted immediately following selection at the program sponsor's place of business. The sponsor adopting this method of selecting apprentices shall meet the requirements of §511.B.1.a-g of this plan relating to creation of the pool of eligibles, oral interviews, and notification of applicants.

b. Goals and Timetables. The sponsor shall establish, where required by §509.D, percentage goals and timetables for admission of minorities and women (minority and nonminority) into the pool of eligibles in accordance with provisions of §509.D, E and F.

c. Compliance. Determinations as to the sponsor's compliance with its obligations under these regulations shall be in accordance with provisions of §511.B.1.g.

### 4. Selection from Pool of Current Employees

a. Selection. A sponsor may select apprentices from an eligibility pool of the workers already employed by the program sponsor in a manner prescribed by a collective bargaining agreement where such exists, or by the sponsor's established promotion policy. The sponsor adopting this method of selecting apprentices shall establish goals and timetables for selection of minority and female (minority and nonminority) apprentices, unless the sponsor concludes in accordance with provisions of §509.D, E, and F that it does not have deficiencies in terms of underutilization of minorities and/or women in the apprenticeship of journeyman crafts represented by the program.

b. Compliance. Determinations as to the sponsor's compliance with its obligations under these regulations shall be in accordance with provisions of §511.B.1.g of this plan.

5. Alternative Selection Method. A sponsor may select apprentices by means of any other method, including its

present selection method, providing that the sponsor meets the following requirements:

a. Selection Method, Goals, and Timetables. Within 90 days of the effective date of this plan, the sponsor shall submit to the council a detailed statement of the selection method it proposes to use, along with the rest of its written affirmative action program. It should include, when required by §509.D, its percentage goals and timetables for selection of minority and/or female (minority and nonminority) applicants for apprenticeship and its written analysis upon which such goals and timetables, or lack thereof, are based. Establishment of goals and timetables must be in accordance with provisions of §509.D, E and F. The sponsor may not implement any such selection method until the council has approved the selection method as meeting requirements of §511.B.5.b and has approved the remainder of its affirmative action program including its goals and timetables. If the council fails to act upon the selection method and the affirmative action program within 30 days of its submission, the sponsor may then implement the selection method.

b. Qualification Standards. Apprentices shall be selected on the basis of objective and specific qualification standards. Examples of such standards are fair aptitude tests, school diplomas or equivalent, occupationally essential physical requirements, fair interviews, school grades, and previous work experience. When interviews are used, adequate records shall be kept including a brief summary of each interview and the conclusions on each of the specific factors, e.g., motivation, ambition, and willingness to accept direction, all of which are factors of the total judgment. In applying any such standards, the sponsor shall meet the requirements of 41 CFR Part 60-3.

c. Compliance. Determination of the sponsor's compliance with its obligations under these regulations shall be in accordance with provisions of §511.B.1.g. When a sponsor, despite its good-faith efforts, fails to meet its goals and timetables within a reasonable period of time, the sponsor may be required to make appropriate changes in its affirmative action program to the extent necessary to obtain maximum effectiveness toward attainment of its goals. The sponsor also may be required to develop and adopt an alternative selection method, including a method prescribed by the council, when it is determined that the failure of the sponsor to meet its goals is attributable in substantial part to the selection method. When the sponsor's failure to meet its goals is attributable in substantial part to its use of a qualification standard which has adversely affected opportunities of minority and/or women (minority and nonminority) for apprenticeship, the sponsor maybe required to demonstrate that such qualification standard is directly related to job performance, in accordance with provisions of §511.B.1.a.

AUTHORITY NOTE: Promulgated in accordance with R.S. 23:381-391..

HISTORICAL NOTE: Promulgated by the Department of Labor, Office of Labor, LR 12:435 (July 1986), amended LR 17:356 (April 1991), amended by the Louisiana Workforce Commission, Office of Workforce Development, LR 37:2220 (July 2011).

**§513. Existing List of Eligibles and Public Notices**

A. A sponsor adopting a selection method under §511.B.2 or 3 and a sponsor adopting a selection method under §511.B.5 who determines that there are fewer minorities and/or women (minority and nonminority) on its existing lists of eligibles than would reasonably be expected in view of the analysis described in §509.E shall discard all existing eligibility lists upon adoption of selection methods required by this plan. New eligibility pools shall be established, and lists of eligibility pools be posted at the sponsor's place of business. Sponsors shall establish a reasonable period of not less than two weeks for accepting applications for admission to an apprenticeship program. There shall be at least 30 days of public notice in advance of the earliest date for application for admission to the apprenticeship program (see §509.C on affirmative action with respect to dissemination of information).

B. Applicants who have been placed in a pool of eligibles shall be retained on lists of eligibles subject to selection for a period of two years. Applicants may be removed from the list at an earlier date by their request or following their failure to respond to an apprentice job opportunity given by certified mail, return receipt requested.

C. Applicants who have been accepted in the program shall be afforded a reasonable period of time in light of customs and practices of the industry for reporting for work. All applicants shall be treated equally in determining such period of time. It shall be the responsibility of the applicant to keep the sponsor informed of his or her current mailing address. A sponsor may restore to the list of eligibles an applicant who has been removed from the list at his request or who has failed to respond to an apprenticeship job opportunity.

AUTHORITY NOTE: Promulgated in accordance with R.S. 23:381-291.

HISTORICAL NOTE: Promulgated by the Department of Labor, Office of Labor, LR 12:436 (July 1986), amended LR 17:356 (April 1991), amended by the Louisiana Workforce Commission, Office of Workforce Development, LR 37:2221 (July 2011).

**§515. Records**

A. Obligations of Sponsors. Each sponsor shall keep adequate records including a summary of qualifications of each applicant; the basis for evaluation and for selection or rejection of each applicant; a record pertaining to interviews of applicants; the original application for each applicant; information relative to the operation of the apprenticeship program, including but not limited to job assignment, promotion, demotion, layoff, or termination, rates of pay, or other forms of compensation or conditions of work and, separately, hours of training provided; and any other records pertinent to a determination of compliance with these regulations, as may be required by the apprenticeship division. The records pertaining to individual applicants, whether selected or rejected, shall be maintained in such a manner as to permit identification of minority and female (minority and nonminority) participants.

B. Affirmative Action Plans. Each sponsor must retain a statement of its affirmative action plan required by §509 for the prompt achievement of full and equal opportunity in apprenticeship, including all data and analysis made pursuant to requirements of §509. Sponsors shall annually review their affirmative action plans and update them when necessary, including the goals and timetables.

C. Qualification Standards. Each sponsor must maintain evidence that its qualification standards have been validated in accordance with requirements set forth in §511.B.

D. Maintenance of Records by Sponsors. All records required by this plan and any other information relevant to compliance with these regulations, shall be maintained for five years, and made available, upon request, to the Louisiana Workforce Commission, Apprenticeship Division, the U.S. Department of Labor, or other authorized persons.

E. Records of the Louisiana Workforce Commission, Apprenticeship Division. The apprenticeship division shall keep adequate records, including registration requirements, approved individual program standards, registration records, deregistration records, program compliance reviews and investigations, individual program ethnic count, total apprenticeship ethnic count, and any other records pertinent to a determination of compliance with this plan as may be required by the U.S. Department of Labor, and shall report such to the U.S. Department of Labor Office of Apprenticeship, semi-annually.

AUTHORITY NOTE: Promulgated in accordance with R.S. 23:381-391.

HISTORICAL NOTE: Promulgated by the Department of Labor, Office of Labor, LR 12:437 (July 1986), amended LR 17:356 (April 1991), amended by the Louisiana Workforce Commission, Office of Workforce Development, LR 37:2222 (July 2011).

**§517. Compliance Reviews**

A. Conduct of Compliance Reviews. The council will regularly conduct systematic reviews of apprenticeship programs in order to determine the extent to which sponsors are complying with these regulations. The council also will conduct compliance reviews when circumstances, including receipt of complaints not referred to a private review body pursuant to §521.B.1, so warrant, and take appropriate action regarding programs which are not in compliance with the requirements of this plan. Compliance reviews will consist of comprehensive analysis and evaluation of each aspect of the apprenticeship program, including onsite investigations and audits.

B. Reregistration. A sponsor seeking reregistration shall be subject to a compliance review as described in §517.A as part of the registration process.

C. New Registration. Sponsors seeking new registration shall be subject to a compliance review as described in §517.A by the apprenticeship division as part of the registration process.

D. Voluntary Compliance. When a compliance review indicates that the sponsor is not operating in accordance with

this plan, the apprenticeship division shall notify the sponsor in writing of results of the review and make a reasonable effort to secure voluntary compliance on the part of the program sponsor within a reasonable time before undertaking sanctions described under §525. In the case of sponsors seeking new registration, the apprenticeship division will provide appropriate recommendations to the sponsor to enable it to achieve compliance for registration purposes.

**AUTHORITY NOTE:** Promulgated in accordance with R.S. 23:381-391.

**HISTORICAL NOTE:** Promulgated by the Department of Labor, Office of Labor, LR 12:437 (July 1986), amended LR 17:356 (April 1991), amended by the Louisiana Workforce Commission, Office of Workforce Development, LR 37:2222 (July 2011).

### **§519. Noncompliance with Federal and State Equal Opportunity Requirements**

A. A pattern or practice of noncompliance by a sponsor (or when the sponsor is a joint apprenticeship committee, by one of the parties represented on such committee) with federal or state laws or regulations requiring equal opportunity may be grounds for imposition of sanctions in accordance with §525 if such noncompliance is related to equal employment opportunities of apprentices and/or graduates of such an apprenticeship program under this plan. The sponsor shall take affirmative steps to assist and cooperate with employers and unions in fulfilling their equal employment opportunity obligations.

**AUTHORITY NOTE:** Promulgated in accordance with R.S. 23:381-391.

**HISTORICAL NOTE:** Promulgated by the Department of Labor, Office of Labor, LR 12:437 (July 1986), amended LR 17:356 (April 1991), amended by the Louisiana Workforce Commission, Office of Workforce Development, LR 37:2222 (July 2011).

### **§521. Complaint Procedure**

#### **A. Filing**

1. Any apprentice or applicant for apprenticeship who believes that he or she has been discriminated against on the basis of race, color, religion, national origin, or sex, with regard to apprenticeship, or that equal opportunity standards with respect to his or her selection have not been followed during an apprenticeship program may, by himself/herself, or by an authorized representative, file a complaint with the apprenticeship division, or at the apprentice's or applicant's election with a private review body established pursuant to §521.A.3. The complaint shall be in writing and signed by the complainant. It must include the name, address, and telephone number of the person allegedly discriminated against, the program sponsor involved, and a brief description of the circumstances of the failure to apply the equal opportunity standards provided for in this plan.

2. The complaint must be filed not later than 180 days from the date of the alleged discrimination or specified failure to follow equal opportunity standards. In the case of complaints filed directly with review bodies designated by program sponsors to review such complaint, any referral of

such complaint by the complainant to the apprenticeship division must occur within the time limitation stated above or 30 days from the final decision of such review body, whichever is later. The time may be extended by the apprenticeship division for good cause shown.

3. Sponsors are encouraged to establish fair, speedy, and effective procedures for a review body to consider complaints of failure to follow equal opportunity standards. A private review body established by the program sponsor for this purpose should number three or more responsible persons from the community serving in this capacity without compensation. Members of the review body should not be directly associated with administration of an apprenticeship program. Sponsors may join together in establishing a review body to serve the needs of programs within the community.

#### **B. Processing of Complaints**

1. When the sponsor has designated a review body for reviewing complaints, and if the Apprenticeship Division determines that such review body will effectively enforce equal opportunity standards, the Apprenticeship Division, upon receiving a complaint, shall refer the complaint to the review body.

2. The Apprenticeship Division shall, within 30 days following referral of a complaint to the review body, obtain reports from a complainant and the review body as to the disposition of the complaint. If the complaint has been satisfactorily adjusted, and there is no other indication of failure to apply equal opportunity standards, the case shall be closed and all parties appropriately informed.

3. When a complaint has not been resolved by the review body within 90 days, or when, despite satisfactory resolution of the particular complaint by the review body, there is evidence that equal opportunity practices of the apprenticeship program are not in accordance with this plan, the apprenticeship division may conduct such compliance review as found necessary and will take all necessary steps to resolve the complaint.

4. Where no review body exists, the apprenticeship division may conduct such compliance review as found necessary in order to determine all facts of the complaint, and obtain such other information relating to compliance with these regulations as circumstances warrant.

5. Sponsors shall provide written notice of the above complaint procedure to all applicants for apprenticeship and all apprentices.

**AUTHORITY NOTE:** Promulgated in accordance with R.S. 23:381-391.

**HISTORICAL NOTE:** Promulgated by the Department of Labor, Office of Labor, LR 12:437 (July 1986), amended LR 17:356 (April 1991), amended by the Louisiana Workforce Commission, Office of Workforce Development, LR 37:2223 (July 2011).

### **§523. Adjustments in Schedule for Compliance Review or Complaint Processing**

A. If, in the judgment of the Apprenticeship Division, a particular situation warrants and requires special processing and either expedited or extended determination, it shall take steps necessary to permit such determination if it finds that no person or party affected by such determination will be prejudiced by such special processing.

AUTHORITY NOTE: Promulgated in accordance with R.S. 23:381-391.

HISTORICAL NOTE: Promulgated by the Department of Labor, Office of Labor, LR 12:438 (July 1986), amended LR 17:356 (April 1991), amended by the Louisiana Workforce Commission, Office of Workforce Development, LR 37:2223 (July 2011).

### **§525. Sanctions**

A. When the Apprenticeship Division, as a result of a compliance review or other reason, determines that there is reasonable cause to believe that an apprenticeship program is not operating in accordance with this plan, and voluntary corrective action has not been taken by the program sponsor, the apprenticeship division shall institute proceedings to deregister the program or it shall refer the matter to the U.S. Department of Labor for referral to the Equal Employment Opportunity Commission or the attorneyGeneral with recommendations for institution of a court action by the attorney general under Title VII of the Civil Rights Act of 1964 ,as amended, or the attorney general for other court action as authorized by law.

B. Deregistration proceedings shall be conducted in accordance with the following procedures.

1. The Apprenticeship Division shall notify the sponsor in writing that a determination of reasonable cause has been made under provisions of §525.A and that the apprenticeship program may be deregistered unless, within 15 days of receipt of the notice, the sponsor requests a hearing. The notification shall specify the facts on which the determination is based.

2. If within 15 days of receipt of the notice provided for in §525.B.1, the sponsor mails a request for hearing, the executive director, Louisiana Workforce Commission, Apprenticeship Division, shall convene a hearing in accordance with §525.C.

3. The executive director, Louisiana Workforce Commission, Apprenticeship Division, shall make a final decision on the basis of the records, which shall consist of the compliance review file and other evidence presented, and if a hearing was conducted pursuant §525.C, the proposed findings and recommended decision of the hearing officer. The executive director, Louisiana Workforce Commission, Apprenticeship Division, may allow the sponsor reasonable time to take voluntary corrective action. If the Executive Director's decision is that the apprenticeship program is not operating in accordance with this plan, the apprenticeship program shall be deregistered. In each case in which deregistration is ordered, the executive director shall make public notice of the order and shall notify the sponsor and

the complainant, if any, and the U.S. Department of Labor. The apprenticeship division shall inform any sponsor whose program has been deregistered that it may appeal such deregistration to the U.S. Department of Labor in accordance with procedure set forth at 29 CFR 30.15.

C. Hearings. Hearing shall be conducted in accordance with the following procedures.

1. Within 10 days of receipt of a request for a hearing, the executive director, Louisiana Workforce Commission, Apprenticeship Division, shall designate a hearing officer. The hearing officer shall give reasonable notice of such hearing by certified mail, return receipt requested, to the sponsor. Such notice shall include a reasonable time and place of hearing, a statement of the provisions of this plan pursuant to which the hearing is to be held, and a concise statement of the matters pursuant to which the action forming the basis of the hearing is proposed to be taken.

2. The hearing officer shall regulate the course of the hearing. Hearings shall be informally conducted. Every party shall have the right to counsel and a fair opportunity to present his case, including such cross-examination as may be appropriate in the circumstances. Hearing officers shall make their proposed findings and recommended decisions to the Executive Director upon the basis of the record before them.

AUTHORITY NOTE: Promulgated in accordance with R.S. 23:381-391.

HISTORICAL NOTE: Promulgated by the Department of Labor, Office of Labor LR 12:438 (July 1986), amended LR 17:356 (April 1991), amended by the Louisiana Workforce Commission, Office of Workforce Development, LR 37:2223 (July 2011).

### **§527. Reinstatement of Program Registration**

A. Any apprenticeship program deregistered pursuant to this plan may be reinstated upon presentation of adequate evidence to the director of apprenticeship and state apprenticeship council, that the apprenticeship program is operating in accordance with this plan.

AUTHORITY NOTE: Promulgated in accordance with R.S. 23:381-391.

HISTORICAL NOTE: Promulgated by the Department of Labor, Office of Labor, LR 12:438 (July 1986), amended LR 17:356 (April 1991), amended by the Louisiana Workforce Commission, Office of Workforce Development, LR 37:2224 (July 2011).

### **§529. Intimidatory or Retaliatory Acts**

A. Any intimidation, threat, coercion, or retaliation by or with the approval of any sponsor against any person for the purpose of interfering with any right or privilege secured by Title VII of the Civil Rights Act of 1964, as amended, Executive Order 11246 , as amended, or because he or she as made a complaint, testified, assisted, or participated in any manner in any investigation proceeding or hearing under this plan, shall be considered noncompliance with the equal opportunity standards of this plan. The identity of complainants shall be kept confidential except to the extent necessary to carry out the purposes of this plan, including

conduct of any investigation, hearing or judicial proceeding arising there from.

**AUTHORITY NOTE:** Promulgated in accordance with R.S. 23:381-391.

**HISTORICAL NOTE:** Promulgated by the Department of Labor, Office of Labor, LR 12:438 (July 1986), amended LR 17:356 (April 1991), amended by the Louisiana Workforce Commission, Office of Workforce Development, LR 37:2224 (July 2011).

### §531. Nondiscrimination

A. The commitments contained in the sponsor's affirmative action program are not intended, and shall not be used, to discriminate against any qualified applicant or apprentice on the basis of race, color, religion, national origin, or sex.

**AUTHORITY NOTE:** Promulgated in accordance with R.S. 23:381-391.

**HISTORICAL NOTE:** Promulgated by the Department of Labor, Office of Labor, LR 12:438 (July 1986), amended LR 17:356 (April 1991), amended by the Louisiana Workforce Commission, Office of Workforce Development, LR 37:2224 (July 2011).

### §533. Exemptions

A. Requests for exemption from these regulations, or any part thereof, shall be made in writing to the director of apprenticeship and shall contain a statement of reasons supporting the request. Exemptions may be granted for good cause. The Apprenticeship Division will immediately notify the U.S. Department of Labor of any such exemptions granted affecting a substantial number of employees and reasons therefore.

B. Partial exemptions may be granted from three requirements namely:

1. adoption of an affirmative action plan;
2. adoption of selection procedures; and
3. discard of existing eligibility lists.

C. Sponsors eligible for exemption are those who are subject to an equal employment opportunity program providing for selection of apprentices, and for affirmative action in apprenticeship which has been approved as meeting requirement of Title VII of the Civil Rights Act of 1964, as amended (42 U.S.C. 2000e et seq.) and its implementing regulations published in Title 29 of the Code of Federal Regulations, Chapter XIV, or Executive Order 11246, as amended, and its implementing regulations at Title 41 of the Code of Federal Regulations, Chapter 60.

**AUTHORITY NOTE:** Promulgated in accordance with R.S. 23:381-391.

**HISTORICAL NOTE:** Promulgated by the Department of Labor, Office of Labor, LR 12:438 (July 1986), amended LR 17:356 (April 1991), amended by the Louisiana Workforce Commission, Office of Workforce Development, LR 37:2224 (July 2011).

### §535. Severability Clause

A. These rules and each of their provisions are hereby declared to be severable, one from another. If any provision or item of a rule, or the application thereof, is held invalid, such invalidity shall not effect other provisions, items, or applications of the rule which can be given effect without the invalid provision, item or application.

**AUTHORITY NOTE:** Promulgated in accordance with R.S. 23:381-391.

**HISTORICAL NOTE:** Promulgated by the Department of Labor, Office of Labor, LR 12:439 (July 1986), amended LR 17:356 (April 1991), amended by the Louisiana Workforce Commission, Office of Workforce Development, LR 37:2224 (July 2011).

## Chapter 7. Apprenticeship Tax Credit

### §701. Authority

A. Under the authority set out in Act 472 of the 2007 Regular Session of the Louisiana Legislature, a tax credit is hereby provided as an incentive for businesses to employ eligible apprentices with a goal toward providing an adequate number of Louisiana citizens in the workforce with the on-the-job training necessary to find jobs and keep those good paying jobs already present as well as those jobs that would be here if more of the workforce was of higher quality. The Secretary of Labor is required to adopt regulations for the purpose of implementing this Act.

**AUTHORITY NOTE:** Promulgated in accordance with R.S. 47:6026.

**HISTORICAL NOTE:** Promulgated by the Louisiana Department of Labor, Office of Workforce Development, Apprenticeship Division, LR 33:2664 (December 2007).

### §703. Definitions

*Department*—the state Department of Labor, Apprenticeship Division.

*Eligible Apprentice*—a person who has entered into a written apprentice agreement with an employer or an association of employers pursuant to a registered apprenticeship program as provided for in Chapter 4 of Title 23 of the Louisiana Revised Statutes of 1950 (R.S. 23:381 et seq.)

*Employer or Requesting Party*—any person or organization employing an eligible apprentice either as a recognized program sponsor or as an obligated employer participant in an apprenticeship training program under a different program sponsor registered with the department. It may also be any person or organization employing an NCCER apprentice in accordance with this Chapter.

*NCCER*—the National Center for Construction Education and Research.

*NCCER Apprentice*—a person who is enrolled in a training program accredited by the National Center for Construction Education and Research which has no less than four levels of training and no less than 500 hours of instruction.

*Program Sponsor*—any person or organization operating a state apprenticeship program registered by and in good standing with the state Department of Labor, Apprenticeship Division.

*Revenue*—the Louisiana Department of Revenue.

*Secretary of Labor*—the administrator of the state Department of Labor, or any person specifically designated by the Secretary of Labor, Department of Labor who with the advice of the state Director of Apprenticeship, executes apprenticeship policy and standards.

*Standards of Apprenticeship*—an organized, written plan embodying the terms and conditions of employment, training, and supervision of one or more apprentices in an apprenticeable occupation and in accordance with §301 of this Part.

*State Apprenticeship Program*—a program registered by and in good standing with the state Department of Labor, Apprenticeship Division and meeting the minimum standards of the state apprenticeship law.

*State Director of Apprenticeship*—the administrator of the state Department of Labor, Apprenticeship Division, or any person specifically designated by the state Director of Apprenticeship who is authorized to administer the provisions of Louisiana apprenticeship law and rule.

*Taxpayer*—any corporation, S corporation, partnership, or individual subject to income and/or franchise taxes imposed under Title 47 of the Louisiana Revised Statutes.

*Taxable Period*—the taxpayer's annual accounting period, whether it be a calendar year or a fiscal year or the period for which the return is made, if a return is made for a period of less than 12 months.

AUTHORITY NOTE: Promulgated in accordance with R.S. 47:6026.

HISTORICAL NOTE: Promulgated by the Louisiana Department of Labor, Office of Workforce Development, Apprenticeship Division, LR 33:2664 (December 2007).

### §705. Purpose

A. The Louisiana State Legislature has determined that a major impediment to the economy of the state is the lack of an adequate number of people in the workforce with sufficient on-the-job training to find and keep good paying jobs already present as well as those that would be here if more of the workforce was of higher quality. The purpose of this tax credit is to provide an incentive for businesses to employ apprentices with a goal toward providing such a workforce.

AUTHORITY NOTE: Promulgated in accordance with R.S. 47:6026.

HISTORICAL NOTE: Promulgated by the Louisiana Department of Labor, Office of Workforce Development, Apprenticeship Division, LR 33:2665 (December 2007).

### §707. Eligibility

A. Any taxpayer who employs an eligible apprentice duly indentured and registered under the approved Standards of Apprenticeship terms of a state apprenticeship program or

a person who is enrolled in a training program accredited by the National Center for Construction Education and Research which has no less than four levels of training and no less than 500 hours of instruction is entitled to a non-refundable apprentice tax credit against any Louisiana individual or corporation income tax or corporation franchise tax each tax year equal to \$1 for each hour of employment of each eligible apprentice, not to exceed 1,000 hours for each eligible apprentice provided such apprenticeships meet the following requirements.

1. A pre-apprentice shall not be considered to be an eligible apprentice, and a pre-apprentice is therefore not eligible for tax credits under this regulation.

2. For state apprenticeship training programs and for purposes of this tax credit only, the tax credit shall be limited to programs which are not less than 4,000 hours (2 years) of on the job training nor more than 10,000 hours (5 years) of on the job training according to the approved Standards of Apprenticeship.

3. Existing procedures and policies for the awarding of advanced status to apprentices for previous training or work experience will remain in effect. Time awarded in recognition of satisfactory completion of previous training or work experience shall not be eligible for a tax credit.

4. In accordance with Louisiana apprenticeship law, rule and policy, a finding that a state apprenticeship program is not in compliance with its approved standards of apprenticeship shall be sufficient cause for revocation of tax credit eligibility. Such revocation shall be applied regardless if the program sponsor is an employer, an association of employers, or an organization of employees for a period of one year or until such program has established compliance with said standards.

5. For NCCER apprentices, the state Department of Revenue shall determine, through rules, the enrollment and transcript data required from the National Center for Construction Education and Research for students enrolled in one of its accredited training programs which is sufficient for the department to determine the employer's eligibility for, and the amount of the credit, authorized by Public Act 472.

6. In order to be eligible for the tax credit, an NCCER apprentice enrolled in a training program accredited by the National Center for Construction Education and Research must have successfully completed no less than two levels of training and no less than 250 hours of instruction. Employers requesting the tax credit shall receive such tax credit only after such eligibility has been met and confirmed. The tax credit shall only apply to hours completed after the initial requirement has been met.

AUTHORITY NOTE: Promulgated in accordance with R.S. 47:6026.

HISTORICAL NOTE: Promulgated by the Louisiana Department of Labor, Office of Workforce Development, Apprenticeship Division, LR 33:2665 (December 2007).

**§709. Method of Computation**

A. Computing Tax Credit. To compute the tax credit allowable to an employer that has an approved state apprenticeship program, the following procedure is to be followed.

1. First, identify the calendar months during the current tax period claimed in which each eligible apprentice was employed.

2. Second, add the number of hours worked by the eligible apprentice in each calendar month in which an eligible apprentice was employed.

3. Third, add the number of eligible monthly hours within the tax period claimed.

4. Finally, multiply the result reached in the step above by \$1 to arrive at the total tax credit for the tax period, not to exceed \$1,000 for each eligible apprentice.

AUTHORITY NOTE: Promulgated in accordance with R.S. 47:6026.

HISTORICAL NOTE: Promulgated by the Louisiana Department of Labor, Office of Workforce Development, Apprenticeship Division, LR 33:2665 (December 2007).

**§711. Method of Reporting**

A. The department shall provide to the state Department of Revenue an annual list of businesses which participate in state apprenticeship programs as well as the number of eligible apprentices that each employer has employed for the year.

1. For purposes of this tax credit, a state apprenticeship program in good standing shall provide to the department a list of active apprentices for each year. The state Director of Apprenticeship shall verify the registration of apprentices and shall then forward such information to the state Department of Revenue

B. The state Department of Revenue shall make a final determination on all requests for the apprenticeship tax credit.

C. All records pertaining to the apprenticeship tax credit shall be retained by the employer requesting the tax credit for a period not less than five calendar years.

AUTHORITY NOTE: Promulgated in accordance with R.S. 47:6026.

HISTORICAL NOTE: Promulgated by the Louisiana Department of Labor, Office of Workforce Development, Apprenticeship Division, LR 33:2665 (December 2007).

**§713. Limitations**

A. The tax credit shall be allowed against income tax or corporate franchise tax for the taxable period in which the credit is earned. If the tax credit exceeds the amount of such

taxes due, then any unused credit may be carried forward as a credit against subsequent tax liability for a period not to exceed 10 years.

1. The credit for taxes paid by or on behalf of a corporation shall be applied against Louisiana corporate income and corporation franchise taxes of such corporation.

2. The credit for taxes paid by an individual shall be applied against Louisiana personal income taxes.

3. The credit for taxes paid by or on behalf of a corporation classified under Subchapter S of the Internal Revenue Code of 1954, as amended, as an S corporation shall be applied first against any Louisiana corporate income and corporation franchise taxes due by such S corporation, and the remainder of any such credit shall be allocated to the shareholder or shareholders of such S corporation in accordance with their respective interests and applied against the Louisiana income tax of such shareholder or shareholders of the S corporation.

4. The credit for taxes paid by or on behalf of a partnership shall be allocated to the partners according to their distributive shares of partnership gross income and applied against any Louisiana income tax and corporation franchise tax liability of such partners.

5. The character of the credit for taxes paid by or on behalf of a partnership or S corporation and allocated to the partners or shareholders, respectively, of such partnership or S corporation, shall be determined as if such credit were incurred by such partners or shareholders, as the case may be in the same manner as incurred by the partnership or S corporation, as the case may be.

6. The credit for taxes paid by an estate or trust shall be applied against the Louisiana income tax imposed on estates and trusts.

B. The apprenticeship tax credit shall have an effective period beginning January 1, 2008, and shall not extend beyond December 31, 2011. All requests for the tax credit for hours worked by eligible apprentices and NCCER apprentices outside of this period shall be invalid and denied.

C. Nothing in this Chapter or in any apprentice agreement approved under this Chapter shall operate to invalidate any apprenticeship provision in any collective agreement between employers and employees.

AUTHORITY NOTE: Promulgated in accordance with R.S. 47:6026.

HISTORICAL NOTE: Promulgated by the Louisiana Department of Labor, Office of Workforce Development, Apprenticeship Division, LR 33:2666 (December 2007).



**Title 40**  
**LABOR AND EMPLOYMENT**  
**Part XIII. Job Training Partnership Act**

**Chapter 1. General Provisions**

**§101. Definitions**

*Capital Improvement*—any modification, addition, restoration, or other improvement:

1. which increases the usefulness, productivity, or serviceable life of an existing building, structure, or major item of equipment;
2. which is classified for accounting purposes as a "fixed asset;" and
3. the cost of which increases the recorded value of the existing building, structure, or major item of equipment and is subject to depreciation.

*Construction*—the erection, installation, assembly, or painting of a new structure or a major addition, expansion, or extension of an existing structure, and the related site preparation, excavation, filling and landscaping, or other land improvement.

*Consulting Service*—work, other than professional, personal, or social service, rendered by either individuals or firms who possess specialized knowledge, experience, or expertise to investigate assigned problems or projects and to provide counsel, review, design, development, analysis, or advice in formulating or implementing programs or services, or improvements in programs or services, including but not limited to such areas as management, personnel, finance, accounting, planning, data processing, and advertising contracts, except for printing associated therewith.

*Dependent*—any person for whom, both currently and during the previous 12 months, the applicant has assumed 50 percent of his support, and is:

1. a member of the immediate household (parent, spouse, or child);
2. not a member of the household, but a parent, child or spouse of the applicant, who is unemployed because of a mental or physical disability; or
3. one who may be claimed as a dependent on the applicant's tax return.

*Employing Agency*—any public or private employer which employs participants and which establishes and maintains the personnel standards applicable to those participants covering such areas as wage rates, fringe benefits, job titles, and employment status.

*Entry Level*—the lowest position in any promotional line, as defined locally by collective bargaining agreements, past practice, or applicable personnel rules.

*Family* (as defined by Section 4(34) of the Act)—

1. two or more persons living in a single residence, as defined in §626.5 of the regulations, related by blood, marriage, or decree of court and are included in one or more of the following categories (a stepchild or a stepparent is considered to be related by marriage):

- a. husband, wife and dependent child;
- b. parent or guardian and dependent child;
- c. husband and wife;

2. for purposes of §101.*Family*.1, persons not living in the single residence but who were claimed as a dependent on another person's Federal Income Tax return for the previous year, unless otherwise demonstrated, shall be presumed to be part of the other person's family;

3. a handicapped individual may be considered an individual when applying for programs under the Act;

4. an individual 18 years of age or older, except as provided in §101.*Family*.2 or 3, who receives less than 50 percent of support from the family, and who is not the principal earner nor the spouse of the principal earner, is not considered a member of the family. Such an individual is considered a family of one.

*Family Income*—all income received from all sources by all members of the family for the six-month period prior to application computed on an annual basis. Family size shall be the maximum number of family members during the income determination period. When computing family income, income of a spouse, parent or child shall be counted for the portion of the income determination period that the person was actually a part of the family unit of the applicant.

1. In accordance with §626.5 of the JTPA Regulations, for the purpose of determining eligibility, family income includes:

- a. money wages and salaries before any deductions;
- b. net receipts from nonfarm self-employment (receipts from a person's own unincorporated business, professional enterprise, or partnership, after deductions for business expenses);
- c. net receipts from farm self-employment (receipts from a farm which one operates as an owner, renter, or sharecropper, after deductions for farm operating expenses);
- d. regular payments from Social Security, railroad retirement, strike benefits from union funds, workers' compensation, veterans' payments, and training stipends;
- e. alimony;

## LABOR AND EMPLOYMENT

f. military family allotments or other regular support from an absent family member or someone not living in the household;

g. pensions whether private, government employee (including military retirement pay);

h. regular insurance or annuity payments;

i. college or university grants, fellowships, and assistantships;

j. dividends, interest, net rental income, net royalties, periodic receipts from estates or trusts; and

k. net gambling or lottery winnings.

2. Family income does not include:

a. unemployment compensation;

b. child support payments;

c. welfare payments (including Aid to Families with Dependent Children, Supplemental Security Income, Emergency Assistance money payments, and non-federally-funded General Assistance or General Relief money payments);

d. capital gains;

e. any assets drawn down as withdrawals from a bank, the sale of property, a house, or a car;

f. tax refunds, gifts, loans, lump-sum inheritances, one-time insurance payments, or compensation for injury; or

g. non-cash benefits:

i. employer-paid fringe benefits;

ii. food or housing received in lieu of wages;

iii. Medicare or Medicaid;

iv. food stamps;

v. school meals; and

vi. housing assistance.

*Job Training Plan*—the plan of a service delivery area for operating programs under the Act, consisting of the Master Plan and Program Plan.

*Labor Organization*—a local labor organization that represents employees in the service delivery area in the same or substantially equivalent jobs as those for which recipients and subrecipients provide, or propose to provide, employment and training under the Act.

*Limited English Language Proficiency*—the limited ability of a participant, whose native language is not English, to communicate in English, resulting in a job handicap.

*Long-Term Unemployment*—any individual who is unemployed at the time of application and has been unemployed for 15 or more of the 26 weeks immediately prior to such and has limited opportunities for employment and reemployment in the same or similar occupation in the area in which such individual resides, including any older

individual who may have substantial barriers to employment by reason of age.

*Master Plan*—the part of the Job Training Plan which serves as a long-term agreement between the governor and a service delivery area.

*Matching Funds for Eight Percent Programs*—shall include all non-JTPA funds, whether in cash or in kind, used in direct support of employment or training services provided by state or local educational agencies.

*Part-Time Employment*—employment in which a worker is regularly scheduled to work less than the employer's full-time schedule for the worker's position.

*Personal Service*—work rendered by individuals which require use of creative or artistic skills, such as but not limited to graphic artists, sculptors, musicians, photographers, and writers, or which require use of highly technical or unique individual skills or talents, such as, but not limited to, paramedicals, therapists, handwriting analysts, and expert witnesses for adjudications or other court proceedings.

*Placement*—the act of securing unsubsidized employment for or by a participant.

*Professional Service*—work rendered by an independent contractor who has a professed knowledge of some department of learning or science used by its practical application to the affairs of others or in the practice of an art founded on it, which independent contractor shall include but not be limited to lawyers, doctors, dentists, veterinarians, architects, engineers, landscape architects, and accountants. A profession is a vocation founded upon prolonged and specialized intellectual training which enables a particular service to be rendered. The word *professional* implies professed attainments in special knowledge as distinguished from mere skill.

*Program Plan*—the part of the Job Training Plan which consists of the description of program activities and services to be provided by the service delivery area during the program year.

*Property*—all tangible nonconsumable moveable property purchased with funds under the Act. The term moveable distinguishes this type of property from property attached as a permanent part of a building or structure. Please note that state law requires each item of moveable property having an acquisition cost or appraised value of \$250 or more to be placed on inventory.

*Public Service Employment*—the type of work normally provided by governments and includes, but is not limited to work (including part-time work) in such fields as environmental quality, child care, health care, education, crime prevention and control, prisoner rehabilitation, transportation, recreation, maintenance of parks, streets, and other public facilities, solid waste removal, pollution control, housing and neighborhood improvement, rural development, conservation, beautification, veterans outreach, development of alternative energy technologies, and other fields of human

betterment and community improvement. This activity is distinguished from work experience in that in general PSE is full-time and long term or open-ended and the participant is employed by the agency involved and not the SDA.

*Real Property*—land, including land improvements, structures and appurtenances thereto, excluding movable machinery and equipment.

*Unsubsidized Employment*—employment not financed from funds provided under the Act. In accordance with Section 106(k) of the Act for performance standard purposes, employment means employment for 20 or more hours per week.

*Welfare Recipient*—an individual who receives or whose family receives cash payments under AFDC (Title IV of the Social Security Act), General Assistance, or the Refugee Assistance Act of 1980 (P.L. 96-212). (This term excludes recipients of supplemental security income under Title XVI of the Social Security Act.)

AUTHORITY NOTE: Promulgated in accordance with R.S. 23:2022.

HISTORICAL NOTE: Promulgated by the Department of Labor, Office of Labor, LR 9:331 (May 1983), amended LR 9:473 (July 1983), LR 10:546 (July 1984), LR 12:439 (July 1986), LR 13:359 (June 1987), amended by the Department of Employment and Training, Office of Labor, LR 17:357 (April 1991), amended by the Department of Labor, Office of Labor, LR 19:1581 (December 1993).

#### **§105. Accounting Procedures**

A. Accounting for JTPA funds must be on an accrual basis in accordance with generally acceptable accounting principles. In accordance with §627.430(g)(2) of the regulations, a recipient/subrecipient shall not be required to maintain a separate bank account but shall separately account for federal funds on deposit.

AUTHORITY NOTE: Promulgated in accordance with R.S. 23:2022.

HISTORICAL NOTE: Promulgated by the Department of Labor, Office of Labor, LR 9:333 (May 1983), amended by the Department of Employment and Training, Office of Labor, LR 17:357 (April 1991), amended by the Department of Labor, Office of Labor, LR 19:1583 (December 1993).

#### **§107. Reporting of Expenditures**

A. The service delivery area grant recipient shall prepare expenditure reports in accordance with procedures established by the recipient. These reports shall be on an accrual basis and conform to federal and state requirements in regard to the Act.

AUTHORITY NOTE: Promulgated in accordance with R.S. 23:2022.

HISTORICAL NOTE: Promulgated by the Department of Labor, Office of Labor, LR 9:333 (May 1983), amended by the Department of Employment and Training, Office of Labor, LR 17:357 (April 1991), amended by the Department of Labor, Office of Labor, LR 19:1583 (December 1993).

#### **§109. Requests for Cash**

A. The financing of the JTPA Program will be on an advance or reimbursement basis in accordance with procedures established by the recipient. Service delivery area grant recipients shall establish procedures that will minimize the time elapsing between the receipt of advanced funds and their disbursements in accordance with 31 CFR Part 205. At no time shall the service delivery area grant recipient have funds which exceed three days expenditure needs.

AUTHORITY NOTE: Promulgated in accordance with R.S. 23:2022.

HISTORICAL NOTE: Promulgated by the Department of Labor, Office of Labor, LR 9:333 (May 1983), amended by the Department of Employment and Training, Office of Labor, LR 17:357 (April 1991), amended by the Department of Labor, Office of Labor, LR 19:1584 (December 1993).

#### **§111. Purchasing Procedures**

A. All purchases and leases of furniture, equipment, supplies, property, office and building space, capital improvements, and services shall be processed in accordance with procedures established by the recipient. All purchases of furniture, equipment, supplies, property, office and building space, and capital improvements, with a unit cost of \$5,000 or more must have the prior approval of the recipient.

AUTHORITY NOTE: Promulgated in accordance with R.S. 23:2022.

HISTORICAL NOTE: Promulgated by the Department of Labor, Office of Labor, LR 9:333 (May 1983), amended by the Department of Employment and Training, Office of Labor, LR 17:357 (April 1991), amended by the Department of Labor, Office of Labor, LR 19:1584 (December 1993).

#### **§112. Advertising**

A. Advertising media includes newspapers, magazines, radio and television programs, direct mail, trade papers, and the like. The advertising costs allowable are those which are solely for:

1. recruitment of personnel required for the grant program;
2. solicitation of bids for the procurement of goods and services required;
3. disposal of scrap or surplus materials acquired in the performance of the grant agreement;
4. recruitment of participants, employers, other service providers, and general advertising for the SDA; and
5. other purposes specifically provided for in the grant agreement.

AUTHORITY NOTE: Promulgated in accordance with R.S. 23:2022.

HISTORICAL NOTE: Promulgated by the Department of Labor, Office of Labor, LR 19:1584 (December 1993).

#### **§113. Travel and Transportation Regulations**

A. All reimbursement for travel will be made in accordance with the travel regulations of the recipient,

service delivery area grant recipient, administrative entity or subrecipient. Where subrecipient travel regulations are utilized, they shall, at a minimum, conform with applicable standards of the recipient, service delivery area grant recipient, or administrative entity.

B. Travel costs are allowable for expenses for transportation, lodging, subsistence, and related items incurred by employees who are in travel status on official business incident to the recipient or subrecipient program. Such costs may be charged on an actual basis on a per diem or mileage basis in lieu of actual costs incurred, or on a combination of the two provided the method used is applied to an entire trip and results in charges consistent with those normally allowed in like circumstances in nonfederally sponsored activities. The difference in cost between first-class air accommodations and less-than-first-class air accommodations are unallowable except when less-than-first-class air accommodations are not reasonably available. Each recipient or subrecipient must have clearly defined travel regulations including documentation requirements. These requirements must include travel reports which include the date of travel, travel destination, purpose, beginning and ending odometer reading, amount to be reimbursed, and supervisor signatures.

C. Costs incurred for freight, cartage, express, postage and other transportation costs relating either to goods purchased, delivered, or moved from one location to another are allowable.

**AUTHORITY NOTE:** Promulgated in accordance with R.S. 23:2022.

**HISTORICAL NOTE:** Promulgated by the Department of Labor, Office of Labor, LR 9:333 (May 1983), amended by the Department of Employment and Training, Office of Labor, LR 17:357 (April 1991), amended by the Department of Labor, Office of Labor, LR 19:1584 (December 1993).

#### **§114. Printing and Reproduction Costs**

A. Costs for printing and reproduction services necessary for grant administration, including but not limited to forms, reports, manuals, and informational literature are allowable. Reasonable publication costs of reports or other media relating to grant program accomplishments or results are allowable.

**AUTHORITY NOTE:** Promulgated in accordance with R.S. 23:2022.

**HISTORICAL NOTE:** Promulgated by the Department of Labor, Office of Labor, LR 19:1584 (December 1993).

#### **§115. Personnel, Salary Regulations and Fringe Benefits**

A. All employment practices, salary schedules and related personnel procedures will be in accordance with the regulations of the service delivery area grant recipient, administrative entity or subrecipient.

B. Compensation for personal services includes all remuneration, paid currently or accrued, for services rendered during the period of performance under the grant agreement, including but not necessarily limited to wages, salaries, and supplementary compensation and benefits. The

costs of such compensation are allowable to the extent that total compensation for individual employees:

1. is reasonable for the services rendered;
2. follows an appointment made in accordance with recipient or subrecipient rules; and
3. is determined to be supported as provided below. Compensation surveys providing data representative of the labor market involved will be an acceptable basis for evaluating reasonableness.

C. Amounts charged to grant programs for personnel services will be based on payrolls documented and provided in accordance with generally accepted practice of the recipient or subrecipient. Payrolls must be supported by time and attendance or equivalent records for individuals. Salaries and wages of employees chargeable to more than one grant program or other cost objective will be supported by appropriate time distribution records. The method used should produce an equitable distribution of time and effort.

D. Employee benefits in the form of regular compensation paid to employees during periods of authorized absences from the job, such as for annual leave, sick leave, court leave, military leave and the like are allowable, if they are:

1. provided pursuant to an approved leave system; and
2. the cost thereof is equitably allocated to all related activities, including grant programs.

E. Employee benefits in the form of employers' contribution or expenses for Social Security, employee's life and health insurance coverage, workers' compensation insurance, pension plans, severance pay, and the like, are allowable, provided such benefits are granted under approved plans and are distributed equitably to grant programs and to other activities.

**AUTHORITY NOTE:** Promulgated in accordance with R.S. 23:2022.

**HISTORICAL NOTE:** Promulgated by the Department of Labor, Office of Labor, LR 9:334 (May 1983), amended by the Department of Employment and Training, Office of Labor, LR 17:357 (April 1991), amended by the Department of Labor, Office of Labor, LR 19:1584 (December 1993).

#### **§116. Advisory Councils**

A. Costs incurred by state advisory councils or committees, including the GETCC and PICs, established pursuant to the JTPA Regulations to carry out grant programs are allowable.

**AUTHORITY NOTE:** Promulgated in accordance with R.S. 23:2022.

**HISTORICAL NOTE:** Promulgated by the Department of Labor, Office of Labor, LR 19:1585 (December 1993).

#### **§117. Auditing Requirements**

A. SDA grant recipients, administrative entities and subrecipients who are government or nonprofit entities must comply with the audit requirements of the "Single Audit Act of 1984"/OMB Circular-128 or OMB-Circular 133 as

appropriate. Commercial organizations who are subrecipients shall be audited in accordance with §627.480(a)(3) of the federal regulations. Audit costs for auditing SDA grant recipients and administrative entities will be paid from state administrative funds upon request. Audit costs for subrecipients of SDA grant recipients and administrative entities must be paid by the service delivery area grant recipient or administrative entity. Other subrecipients contracted directly by the Louisiana Department of Labor will be audited in accordance with the "Single Audit Act of 1984" which incorporates the use of private audit firms or the legislative auditors.

**AUTHORITY NOTE:** Promulgated in accordance with R.S. 23:2022.

**HISTORICAL NOTE:** Promulgated by the Department of Labor, Office of Labor, LR 9:334 (May 1983), amended LR 10:546 (July 1984), amended by the Department of Employment and Training, Office of Labor, LR 17:357 (April 1991), amended by the Department of Labor, Office of Labor, LR 19:1585 (December 1993).

### §119. Nonallowable Costs

A. In accordance with §627.435(e), (f), and (i) of the federal regulations some costs associated with JTPA are not considered as necessary and reasonable for proper and efficient administration of the program. These include:

1. costs of fines and penalties resulting from violations of or failure to comply with federal, state, or local laws and regulations;
2. back pay, unless it represents additional pay for JTPA services performed for which the individual was underpaid;
3. entertainment costs;
4. bad debts expenses;
5. insurance policies offering protection against debts established by the federal government;
6. contributions to a contingency reserve or any similar provision for unforeseen events;
7. costs prohibited by 29 CFR Part 93 (Lobbying Restrictions);
8. costs of activities prohibited in §627.205, Public Service Employment Prohibition; §627.210, Nondiscrimination and Nonsectarian Activities; §627.215, Relocation; §627.225, Employment Generating Activities; and §627.230, Displacement of the Federal Regulations;
9. legal services furnished by the chief legal officer of a state or local government or staff solely for the purpose of discharging general responsibilities as a legal officer are unallowable;
10. legal expenses for the prosecution of claims against the federal government, including appeals to an administrative law judge, are unallowable;

11. construction costs are not allowable costs except those specified in §627.435(h)(1) and (2) of the federal regulations;

12. fund-raising activities;

13. interest expense including interest on borrowing, bond discounts, cost of financing and refinancing operations, and legal and professional fees paid in connection therewith; and

14. contributions and donations as specified in OMB Circular A-87.

**AUTHORITY NOTE:** Promulgated in accordance with R.S. 23:2022.

**HISTORICAL NOTE:** Promulgated by the Department of Labor, Office of Labor, LR 9:334 (May 1983), amended by the Department of Employment and Training, Office of Labor, LR 17:357 (April 1991), amended by the Department of Labor, Office of Labor, LR 19:1585 (December 1993).

### §120. Fees or Profits

A. Any fees or profits earned by the SDA grant recipient or subrecipients must be consistent with §627.420(e)(3) of the federal regulations.

**AUTHORITY NOTE:** Promulgated in accordance with R.S. 23:2022.

**HISTORICAL NOTE:** Promulgated by the Department of Labor, Office of Labor, LR 19:1585 (December 1993).

### §121. Carry-Over Balances

A. Funds obligated for any program year may be expended by each recipient or service delivery area grant recipient during that program year and the two succeeding program years with the following exceptions.

1. Title II-A and Title II-C—Reallotment and Reallocation Policy

a. For program years beginning on or after July 1, 1993, the governor shall, in accordance with §109 of the Act and §627.410 of the federal regulations, reallocate to eligible service delivery areas within the state funds appropriated for such program year that are available for reallocation.

b. The amount available for reallocation is equal to the amount by which the unobligated balance of the SDA's allocation under Part A and Part C of Title II at the end of the program year prior to the program year for which the determination is made exceeds 15 percent of such allocation for the prior program year.

c. In addition, Louisiana will use the reallotment process for SDAs at the end of each program year whether or not the state is subject to a reduction in funding due to reallotment. This will allow the state to deal with significant underexpenditure of funds by individual SDAs even when the state maintains a high overall level of expenditures.

d. In the event that Louisiana is not subject to a reduction in funding, but one or more SDAs are subject to a reduction based on Louisiana's policy, funds deobligated from such SDAs will be allocated to the remaining SDAs who are not subject to a reduction that have the highest rates

of unemployment for an extended period of time and to those with the highest poverty rates.

## 2. Title II-B—Reallocation Policy

a. Section 161(b) of the Act provides that no amount of funds "shall be deobligated on account of a rate of expenditure which is consistent with the job training plan." In order to remain consistent with this policy, if an SDA's rate of expenditure is inconsistent with the job training plan, its new obligational authority (NOA) may be reduced in subsequent years in order to, in effect, reallocate funds from that program year.

b. Beginning in Program Year 1995 and applying to Program Year 1994, an amount equivalent to 15 percent of the previous year's total funds available will be classified as "allowable carry-out."

c. All other carry-out will be designed as "excess carry-out" and the obligational authority (NOA) to the SDA will be reduced by the amount of the excess carry-out. Determination of total carry-out and the excess carry-out will be made after submittal of the final program year expenditure report and reallocation of funds will be made to those SDAs which request the funds and have expended more than 85 percent of their total funds available. The reallocation will be based on the degree that SDAs exceed the 85 percent expenditure level.

## 3. Title III—Reallotment and Reallocation Policy

### a. Excess Unexpended Funds

i. The U.S. Department of Labor has established Title III reallotment procedures that have the effect of limiting the amount of unexpended funds that can be carried over by the state at the end of each program year. Reallotment also rewards states with high expenditure rates by providing additional funds. These procedures are described in Section 303 of the Job Training Partnership Act, Section 6305(e) of the Economic Dislocation and Worker Adjustment Assistance Act, §631.12 of JTPA Federal Regulation, and Training and Employment Guidance Letter (TEGL) No. 4-88 issued by the U.S. Department of Labor.

ii. Reallotment will occur around September 1 and will result in an increase or decrease in the state's formula-allotted funds for the current year based on a reallotment process applied to the prior year's Title III funds and expenditures. When reallotment results in an increase in funding, such reallocation is subject to allocation procedures specified in §631.32 of the federal regulations. When reallotment results in a decrease in funding, the procedures that follow will be used to recover funds from substate grantees and, where appropriate, state subcontractors in order to make funds available to the U.S. Department of Labor for reallotment. Any remaining funds would come from the governor's 40 percent funds.

iii. Louisiana will apply the same reallotment procedures to sub-state grantees and state subcontractors that the U.S. Department of Labor applies to the state. Our reallotment policy states that the amount available for

reallotment from substate grantees and state subcontractors is equal to the sum of unexpended funds in excess of 20 percent of the prior year's allocation or subgrant amount and all unexpended previous program year funds. For PY 88 allocations and subgrants, 30 percent shall be substituted for 20 percent in the previous sentence. Unexpended reallocated funds at the end of the year will also be subject to the 20 percent limitation on allowable carry forward. Substate grantees and state subcontractors that lose funds through the reallotment process will use their allocation or subgrant amount before reallotment in order to calculate allowable carry forward.

iv. In addition, Louisiana will use the reallotment process for substate grantees and, where appropriate, state subcontractors at the end of each program year whether or not the state is subject to a reduction in funding due to reallotment. This will allow the state to deal with significant underexpenditure of funds by individual substate grantees and state subcontractors even when the state maintains a high overall level of expenditures.

v. In the event that Louisiana is not subject to a reduction in funding, but one or more substate grantee(s) or state subcontractor(s) are subject to a reduction based on Louisiana's policy, funds deobligated from such substate grantees will be allocated by formula to the remaining substate grantees who were not subject to a reduction. This allocation will be in addition to any funds reallocated by the U.S. Department of Labor and subsequently allocated to substate areas. Any funds deobligated from state subcontractors as a result of these procedures are subject to regular Title III state obligation procedures.

### b. Projected Excess Unexpended Funds

i. Louisiana is subject to a U.S. Department of Labor JTPA Title III reallotment process based on expenditures at the end of each program year. In order to avoid a reduction in funding from such a reallotment, a deobligation procedure has been established.

ii. Title III substate grantees and state subcontractors are subject to deobligation of projected excess unexpended funds based on expenditures during the first five months of their subgrant or subcontract period. Projected excess unexpended funds are defined as any amount of projected unexpended funds in excess of 20 percent of a substate grantee's available funds (excluding carry-in funds and any additional funds reallocated during that program year as a result of the U.S. Department of Labor's reallocation process) or 20 percent of a subcontract amount. Projected unexpended funds are total available funds (excluding reallocated funds) less expenditures reported for the first five months and less an amount equal to the higher of the last two months reported expenditure amounts times the number of months remaining in the subgrant or subcontract period. Expenditure amounts used for this process will be those amounts reported as of the official due date specified by the Louisiana Department of Labor's fiscal section. Funds remaining after deobligation will be subject to all cost category limitations.

iii. Substate grantees and state subcontractors will have 15 days from the date they are notified of any amount subject to deobligation to provide documentation to the Louisiana Department of Labor why they should not be subject to such deobligation. The Louisiana Department of Labor may reduce the amount to be deobligated based on acceptance of documentation of corrected expenditure amounts, significant recent obligations not reflected in current reported expenditures, or other appropriate justification.

iv. All funds deobligated from substate grantees will be allocated by formula to substate grantees whose total projected unexpended funds are not expected to exceed allowable projected unexpended funds. Funds deobligated from state subcontractors are subject to regular Title III state obligation procedures.

v. This deobligation procedure does not limit the Louisiana Department of Labor's authority to unilaterally deobligate funds from subgrants and subcontractors when it is deemed necessary in order to carry out responsibilities under the Job Training Partnership Act.

4. Reallocation Waiver. The reallocation policies may be waived for SDAs and substate grantees operating under a reorganization plan issued by the governor in accordance with procedures established by the recipient.

AUTHORITY NOTE: Promulgated in accordance with R.S. 23:2022.

HISTORICAL NOTE: Promulgated by the Department of Labor, Office of Labor, LR 9:334 (May 1983), amended LR 10:546 (July 1984), LR 15:496 (June 1989), amended by the Department of Employment and Training, Office of Labor, LR 17:357 (April 1991), amended LR 18:372 (April 1992), repromulgated LR 18:493 (May 1992), amended by the Department of Labor, Office of Labor, LR 19:1585 (December 1993).

#### **§122. Depreciation and/or Use Allowance**

A. Compensation for the use of buildings, capital improvements, and equipment through use allowances or depreciation is allowable. Use allowances are the means of providing compensation in lieu of depreciation or other equivalent costs. However, a combination of the two methods may not be used in connection with a single class of fixed assets.

B. The computation of depreciation or use allowance will be in accordance with A-87 Cost Principles for State and Local Governments, Attachment B.

C. Depreciation or use allowance on idle or excess facilities is not allowable, except when specifically authorized by the grantor federal agency.

D. No depreciation or use charge may be allowed on any assets that would be considered as fully depreciated, provided, however, that reasonable use charges may be negotiated for any such assets if warranted after taking into consideration the cost of the facility or item involved, the estimated useful life remaining at time of negotiation, the effect of any increased maintenance charges or decreased efficiency due to age, and any other factors pertinent to the

utilization of the facility or item for the purpose contemplated.

AUTHORITY NOTE: Promulgated in accordance with R.S. 23:2022.

HISTORICAL NOTE: Promulgated by the Department of Labor, Office of Labor, LR 19:1587 (December 1993).

#### **§124. Building Space and Related Facilities**

A. The cost of space in privately or publicly owned buildings used for the benefit of the grant program is allowable subject to the conditions stated below.

B. The total cost of space, whether in a privately or publicly owned building may not exceed the rental cost of comparable space and facilities in a privately owned building in the same locality. The cost of space procured for grant program usage may not be charged to the program for periods of nonoccupancy without authorization of the recipient agency.

C. The cost of utilities, insurance, security, janitorial services, elevator services, upkeep of grounds, normal repairs and alternations and the like, are allowable to the extent they are not otherwise included in the rental or other charges for space.

D. Costs incurred for rearrangement and alteration of facilities required specifically for the grant program or those that materially increase the value or useful life of the facilities are allowable when specifically approved by the recipient.

E. Costs incurred for necessary maintenance, repair, or upkeep of property which neither add to the permanent value of the property nor appreciably prolong its intended life, but keep it in an efficient operating condition are allowable.

F. Depreciation and use allowances on publicly owned buildings are allowable as provided in §122 of these state rules (Depreciation and Use Allowance).

AUTHORITY NOTE: Promulgated in accordance with R.S. 23:2022.

HISTORICAL NOTE: Promulgated by the Department of Labor, Office of Labor, LR 19:1587 (December 1993).

#### **§125. Financial and Programmatic Monitoring and Record Retention**

A. The recipient reserves the right to monitor the financial and programmatic operations of all service delivery area grant recipients. The service delivery area grant recipients shall comply with the record retention requirements at 20 CFR 627.460.

AUTHORITY NOTE: Promulgated in accordance with R.S. 23:2022.

HISTORICAL NOTE: Promulgated by the Department of Labor, Office of Labor, LR 9:334 (May 1983), amended by the Department of Employment and Training, Office of Labor, LR 17:357 (April 1991), amended by the Department of Labor, Office of Labor, LR 19:1587 (December 1993).

**§126. Insurance Costs**

A. Costs of insurance in connection with the general conduct of activities under the program, including but not limited to workers' compensation insurance, insurance for injuries suffered by participants who are not covered by workers' compensation, personal liability insurance for PIC members, and insurance covering the risk of loss of or damage to JTPA property, are allowable subject to the following limitations.

1. Types and extent and cost of coverage will be in accordance with general state and local policy and sound business practice.

2. Contributions to a reserve for a self-insurance program approved by the recipient are allowable to the extent that the type of coverage, extent of coverage, and the rates and premiums would have been allowed had the insurance been purchased to cover the risks.

3. Actual losses which could have been covered by permissible insurance (through an approved self-insurance program or otherwise) are unallowable unless expressly provided for in the grant agreement. However, costs incurred because of losses not covered under nominal deductible insurance coverage provided in keeping with sound management practice, and minor losses not covered by insurance, such as spoilage, breakage and disappearance of small hand tools which occur in the ordinary course of operations, are allowable.

AUTHORITY NOTE: Promulgated in accordance with R.S. 23:2022.

HISTORICAL NOTE: Promulgated by the Department of Labor, Office of Labor, LR 19:1588 (December 1993).

**§127. Inventory Control**

A. Property purchased or assumed under the Act must be maintained in an efficient and effective manner and shall not be used for purposes other than the Act. Service delivery area grant recipients shall obtain written approval from the recipient prior to the disposition of property covered by the Act. Proceeds of such disposition shall be considered program income as regulated by Section 141(m) of the Act and §627.450 of the regulations. Please note that state law requires each item of moveable property having an acquisition cost or appraised value of \$250 or more to be placed on inventory.

AUTHORITY NOTE: Promulgated in accordance with R.S. 23:2022.

HISTORICAL NOTE: Promulgated by the Department of Labor, Office of Labor, LR 9:334 (May 1983), amended by the Department of Employment and Training, Office of Labor, LR 17:357 (April 1991), amended by the Department of Labor, Office of Labor, LR 19:1588 (December 1993).

**§128. Taxes**

A. In general, taxes or payments in lieu of taxes which the recipient/subrecipient is legally required to pay are allowable.

AUTHORITY NOTE: Promulgated in accordance with R.S. 23:2022.

HISTORICAL NOTE: Promulgated by the Department of Labor, Office of Labor, LR 19:1588 (December 1993).

**§129. Contractual Agreement**

A. The service delivery area grant recipients may enter into contractual agreements with any profit and/or nonprofit organization. Service delivery area grant recipients will be responsible for their subrecipients' financial and programmatic operations and will insure compliance with state and federal regulations. Service delivery area grant recipients may require their subrecipients to implement policies in those areas mentioned in these rules similar to the service delivery area grant recipient's policies. The recipient has the right to inspect financial records or program records of any service delivery area grant recipient or subrecipients.

B. In accordance with §627.422 of the federal regulations, each SDA shall ensure that, for all services provided to participants through contracts, grants, or other agreements with a service provider, such contract, grant, or agreement shall include appropriate amounts necessary for administration and supportive services.

AUTHORITY NOTE: Promulgated in accordance with R.S. 23:2022.

HISTORICAL NOTE: Promulgated by the Department of Labor, Office of Labor, LR 9:334 (May 1983), amended by the Department of Employment and Training, Office of Labor, LR 17:357 (April 1991), amended by the Department of Labor, Office of Labor, LR 19:1588 (December 1993).

**§130. Preagreement Costs**

A. Costs incurred prior to the effective date of the grant or contract, whether or not they would have been allowable thereunder if incurred after such date, are allowable when specifically provided for in the grant agreement.

AUTHORITY NOTE: Promulgated in accordance with R.S. 23:2022.

HISTORICAL NOTE: Promulgated by the Department of Labor, Office of Labor, LR 19:1588 (December 1993).

**§131. Bonding**

A. Every officer, director, agent or employee of a service delivery area grant subrecipient of JTPA funds on a cash advance basis, who is authorized to act on behalf of a service delivery area grant recipient for the purpose of receiving or depositing funds into program accounts or issuing financial documents, checks or other instruments of payment for program costs shall be bonded to provide protection against loss. The amount of coverage shall be the lower of the following:

1. \$50,000; or
2. the highest advance through check or drawdown planned during the contract/subgrant period.

AUTHORITY NOTE: Promulgated in accordance with R.S. 23:2022.

HISTORICAL NOTE: Promulgated by the Department of Labor, Office of Labor, LR 9:334 (May 1983), amended by the Department of Employment and Training, Office of Labor, LR 17:357 (April 1991), amended by the Department of Labor, Office of Labor, LR 19:1588 (December 1993).



**§133. Professional, Personal, and Consultant Services**

A. Contracts for professional, personal, and consultant services are allowable with prior written approval of the recipient and in accordance with procedures established by the recipient. Approval must be obtained annually.

B. The costs of management studies to improve the effectiveness and efficiency of grant management for ongoing programs is allowable except that the costs of studies performed by agencies or individuals other than the recipient are allowable only with prior written approval of the recipient.

AUTHORITY NOTE: Promulgated in accordance with R.S. 23:2022.

HISTORICAL NOTE: Promulgated by the Department of Labor, Office of Labor, LR 9:334 (May 1983), amended by the Department of Employment and Training, Office of Labor, LR 17:357 (April 1991), LR 18:372 (April 1992), amended by the Department of Labor, Office of Labor, LR 19:1589 (December 1993).

**§141. Redesignation of Service Delivery Area Grant Recipient**

A. Petitions for redesignation of a service delivery area must be filed with the governor no later than six months before the beginning of the ensuing program year.

AUTHORITY NOTE: Promulgated in accordance with R.S. 23:2022.

HISTORICAL NOTE: Promulgated by the Department of Labor, Office of Labor, LR 9:473 (July 1983), amended by the Department of Employment and Training, Office of Labor, LR 17:357 (April 1991), amended by the Department of Labor, Office of Labor, LR 19:1589 (December 1993).

**§143. Maintenance of Document**

A. The original documents must be maintained unless prior approval from the recipient has been granted to substitute microfilm or similar methods in lieu thereof.

AUTHORITY NOTE: Promulgated in accordance with R.S. 23:2022.

HISTORICAL NOTE: Promulgated by the Department of Labor, Office of Labor, LR 9:334 (May 1983), amended by the Department of Employment and Training, Office of Labor, LR 17:357 (April 1991), amended by the Department of Labor, Office of Labor, LR 19:1589 (December 1993).

**§145. Modification/Amendment of Service Delivery Area Job Training Plan**

A. The approved two-year job training plan may be changed in two ways: by modification and by amendment.

B. A plan modification is a revision of the approved job training plan which requires PIC-CEO approval and is subject to the requirement of Section 104 and 105 of the Act. Summaries of plan modifications must be published for public review and comment no later than 80 days prior to the effective date of the modification. In accordance with Section 104(C) a service delivery area must modify its Job Training Plan when one or more of the following occur:

1. a significant change in labor market or other conditions occurs that would have an adverse impact on its performance;
2. change in grant recipient or administrative entity;
3. change in the geographic area served;
4. a change in funding of more than 20 percent of the annual allocation;
5. obligation of Title II allocations for the second year of the two-year plan period; or
6. any other factors which require modification shall be at the discretion of the governor.

C. A plan amendment is a minor adjustment to the approved job training plan. There is no publication requirement, however PIC/CEO approval is required. A plan amendment must be submitted via a cover letter explaining the amendment and should be signed by the PIC chairperson and CEO.

AUTHORITY NOTE: Promulgated in accordance with R.S. 23:2022.

HISTORICAL NOTE: Promulgated by the Department of Labor, Office of Labor, LR 9:334 (May 1983), amended by the Department of Employment and Training, Office of Labor, LR 17:357 (April 1991), amended by the Department of Labor, Office of Labor, LR 19:1589 (December 1993).

**§147. Participant Rights and Benefits**

A. Each service delivery area grant recipient and its subrecipients shall inform each participant of his rights and benefits at the time of enrollment into any activity under the Act and shall require each participant to sign a statement that he has been advised of his rights and benefits. This signed statement shall become a permanent part of each participant's official record.

AUTHORITY NOTE: Promulgated in accordance with R.S. 23:2022.

HISTORICAL NOTE: Promulgated by the Department of Labor, Office of Labor, LR 9:334 (May 1983), amended by the Department of Employment and Training, Office of Labor, LR 17:357 (April 1991), amended by the Department of Labor, Office of Labor, LR 19:1589 (December 1993).

**§148. Payments to OJT Employers, Training Institutions, and Other Vendors**

A. Payments to On-the-Job Training employers, training institutions and other vendors are allowable and should be made in accordance with applicable sections of the JTPA federal regulations and any procedures established by the recipient.

AUTHORITY NOTE: Promulgated in accordance with R.S. 23:2022.

HISTORICAL NOTE: Promulgated by the Department of Labor, Office of Labor, LR 19:1590 (December 1993).

**§149. Grievance Procedure**

A. Each service delivery area grant recipient and its subrecipients shall adopt a procedure for resolving any grievance including those alleging a violation of the Act,

federal or state regulations, or other agreements under the Act. These procedures shall be in compliance with 20 CFR Part 627 Subpart E and shall be made a part of the service delivery area Job Training Plan. All grievance procedures shall provide for the exhaustion of remedies provided therein before appeal to the governor for review.

AUTHORITY NOTE: Promulgated in accordance with R.S. 23:2022.

HISTORICAL NOTE: Promulgated by the Department of Labor, Office of Labor, LR 9:334 (May 1983), amended by the Department of Employment and Training, Office of Labor, LR 17:357 (April 1991), amended by the Department of Labor, Office of Labor, LR 19:1590 (December 1993).

**§151. Nondiscrimination Procedure**

A. Service delivery area grant recipients and its subrecipients shall comply with the applicable requirements of 29 CFR 31, 32 and 34.

AUTHORITY NOTE: Promulgated in accordance with R.S. 23:2022.

HISTORICAL NOTE: Promulgated by the Department of Labor, Office of Labor, LR 9:335 (May 1983), amended LR 9:473 (July 1983), amended by the Department of Employment and Training, Office of Labor, LR 17:357 (April 1991), amended by the Department of Labor, Office of Labor, LR 19:1590 (December 1993).

**§153. Participant Supportive Services**

A. Participant supportive services, needs-based payments, cash incentive payments and bonuses to youth enrolled in Title II-C, and financial assistance are allowable and should be made in accordance with applicable sections of the JTPA Federal Regulations and procedures established by the recipient. Needs-based payments shall be determined in accordance with a locally developed formula or procedures.

AUTHORITY NOTE: Promulgated in accordance with R.S. 23:2022.

HISTORICAL NOTE: Promulgated by the Department of Labor, Office of Labor, LR 9:335 (May 1983), amended by the Department of Employment and Training, Office of Labor, LR 17:357 (April 1991), amended by the Department of Labor, Office of Labor, LR 19:1590 (December 1993).

**§155. Conditional Approval of Job Training Plan**

A. In order to expedite program operations the governor may, at his option, grant partial or conditional approval to a service delivery area job training plan. Such approval will spell out the parameters within which the job training plan may operate and the revision necessary for final approval.

AUTHORITY NOTE: Promulgated in accordance with R.S. 23:2022.

HISTORICAL NOTE: Promulgated by the Department of Labor, Office of Labor, LR 9:335 (May 1983), amended by the Department of Employment and Training, Office of Labor, LR 17:357 (April 1991), repromulgated by the Department of Labor, Office of Labor, LR 19:1590 (December 1993).

**§159. Administrative Cost Pooling**

A. Funds for the administration of programs under the Act within the service delivery area may be pooled pursuant to §627.440(f) of the regulations.

AUTHORITY NOTE: Promulgated in accordance with R.S. 23:2022.

HISTORICAL NOTE: Promulgated by the Department of Labor, Office of Labor, LR 9:335 (May 1983), amended by the Department of Employment and Training, Office of Labor, LR 17:357 (April 1991), amended by the Department of Labor, Office of Labor, LR 19:1590 (December 1993).

**§161. Statewide Management Information System**

A. Each service delivery area grant recipient will be responsible for maintaining a client tracking and management information system that will interface required data with the Louisiana Department of Labor statewide automated system established for JTPA purposes.

AUTHORITY NOTE: Promulgated in accordance with R.S. 23:2022.

HISTORICAL NOTE: Promulgated by the Department of Labor, Office of Labor, LR 9:335 (May 1983), amended by the Department of Employment and Training, Office of Labor, LR 17:357 (April 1991), amended by the Department of Labor, Office of Labor, LR 19:1590 (December 1993).

**§163. Prevention of Fraud and Program Abuse**

A. To ensure integrity of programs under the Act, special efforts are necessary to prevent fraud and other program abuses. Fraud includes deceitful practices and intentional misconduct, such as willful misrepresentation in accounting for use of program funds. "Abuse" is a general term which encompasses improper conduct which may or may not be fraudulent in nature. While any violation of the Act or regulations may constitute fraud or program abuse, this rule identifies and addresses specific areas which need clarification.

B. This rule sets forth specific responsibilities of recipients, service delivery area grant recipients and subrecipients to prevent fraud and program abuse in JTPA.

C. Conflict of Interest. In addition to the standards set forth below, the State Code of Governmental Ethics contains restrictions concerning conflicts of interest. Any issues regarding the State Code of Governmental Ethics should be brought before the Commission of Ethics for Public Employees.

1. No member of any council under the Act shall cast a vote on the provision of services by that member or any organization which that member directly represents or any matter which would provide direct financial benefit to that member. Caution must be exercised by members to insure that council action does not render the member in violation of R.S. 42:1112, which under certain circumstances may require members to cure the conflict of interest through resignation.

2. Each recipient, service delivery area grant recipient and subrecipients shall avoid personal conflict of interest and appearance of conflict of interest in awarding financial

assistance and in the conduct of procurement activities involving funds under the Act.

3. Neither the recipient, any service delivery area grant recipient nor subrecipients shall pay funds under the Act to any individual, institution, or organization to conduct an evaluation of any program under the Act if such individual, institution, or organization is associated with that program as a consultant or technical advisor.

D. Kickbacks. No officer, employee, or agent of the recipient, service delivery area grant recipient or subrecipients shall solicit or accept gratuities, favors, or anything of monetary value from any actual or potential subrecipient.

E. Commingling of Funds. The recipient, service delivery area grant recipients and subrecipients shall comply with the applicable requirements of 29 CFR 97.21(h) and R.S. 49:321.

F. Nepotism. The State Code of Governmental Ethics contains restrictions against the hiring of certain family members. Questions regarding the hiring of family members should be referred to the Commission on Ethics for Public Employees.

G. Child Labor. The recipient, service delivery area grant recipients and subrecipients shall comply with applicable federal, state and local child labor laws.

#### H. Political Patronage

1. Neither the recipient, service delivery area grant recipients, nor any subrecipients may select, reject, or promote a participant based on that individual's political affiliation or beliefs. The selection or advancement of employees as a reward for political services or as a form of political patronage whether or not political services is partisan in nature, is prohibited.

2. There shall be no selection of subrecipients based on political patronage or affiliation.

#### I. Political Activities

1. No program under the Act may involve political activities, including but not limited to:

a. no participant may engage in partisan or nonpartisan political activities during hours for which the participant is paid with JTPA funds;

b. no participant may, at any time, engage in partisan political activities in which such participant represents himself/herself as spokesperson of the JTPA Program;

c. no participant may be employed or outstationed in the office of a member of Congress or a state or local legislator or on any staff of a legislative committee; and

d. no participant may be employed or outstationed in positions involving political activities in the offices of other elected executive officials. However, since under the responsibility of such elected officials are nonpolitical

activities, placement of participants in such nonpolitical positions is permissible. Service delivery area grant recipients and subrecipients shall develop safeguards to ensure that participants placed in these positions are not involved in political activities. These safeguards will be subject to review and monitoring.

2. Persons governed by Chapter 15 of Title 5, United States Code, the Hatch Act, shall comply with its provisions as interpreted by the United States Office of Personnel Management. These provisions apply:

a. to persons (including participants) employed by state and local government in the administration of the JTPA Program; and

b. generally to any participant whose principal employment is in connection with an activity financed by other federal grants or loans.

J. Lobbying Activities. No funds provided under the Act may be used in any way:

1. to attempt to influence in any manner a member of Congress to favor or oppose any legislation or appropriation by Congress;

2. to attempt to influence in any manner state or local legislators to favor or oppose any legislation or appropriation by such legislators. Communications and consultation with state and local legislators for purposes of providing information such as on matters necessary to provide compliance with the Act shall not be considered lobbying.

K. Sectarian Activities. The Act provides the following prohibitions regarding sectarian activity:

1. participants shall not be employed on the construction, operation or maintenance of so much of any facility as is used or to be used for sectarian instruction or as a place for religious worship; and

2. participants shall not be involved, nor JTPA funds expended, for religious or anti-religious activities.

L. Unionization and Antiunionization Activities/Work Stoppages

1. No funds under the Act shall be used in any way to assist, promote or oppose unionization.

2. No individual shall be required to join a union as a condition for enrollment in a program in which only institutional training is provided, unless such institutional training involves individuals employed under a collective bargaining agreement which contains a union security provision.

3. No participant in work experience may be placed into, or remain working in any position which is affected by labor disputes involving a work stoppage. If such a work stoppage occurs during the grant period, participants in affected positions must:

## LABOR AND EMPLOYMENT

- a. be relocated to positions not affected by the dispute;
- b. be suspended through administrative leave; and
- c. where participants belong to the labor union involved in the work stoppage, be treated in the same manner as any other union member except such members must not remain working in the affected position. The grantee shall make every effort to relocate participants, who wish to remain working, into suitable positions unaffected by the work stoppage.

4. No person shall be referred to or placed in an on-the-job training position affected by a labor dispute involving a work stoppage and no payments may be made to employers for the training and employment of participants in on-the-job training during the periods of work stoppage.

5. Nothing in this Section shall prevent an employer from checking off union dues or service fees pursuant to applicable collective bargaining agreements or state law.

6. No currently employed worker shall be displaced by any participant (including partial displacement such as a reduction in the hours of nonovertime work, wages, or employment benefits).

7. No program under this Act shall impair existing contracts for services or existing collective bargaining agreements, unless the employer and the labor organization concur in writing with respect to any elements of the proposed activities which affect such agreement, or either such party fails to respond to written notification requesting its concurrence within 30 days of receipt thereof.

8. No participant shall be employed or job openings filled when any other individual is on layoff from the same or any substantially equivalent job, or when the employer has terminated the employment of any regular employee or otherwise reduced its workforce with the intention of filling the vacancy so created by hiring a participant whose wages are subsidized under this Act.

9. No jobs shall be created in a promotional line that will infringe in any way upon the promotional opportunities of currently employed individuals.

### M. Maintenance of Effort

1. To ensure maintenance of effort under all programs under the Act, the recipient, service delivery area grant recipients and subrecipients shall ensure that such programs:

- a. result in an increase in employment and training opportunities over those which would otherwise be available;

- b. do not result in the displacement of currently employed workers including partial displacement, such as reduction in hours of nonovertime work, wages, or employment benefits;

- c. do not impair existing contracts for services or result in the substitution of federal funds for other funds in connection with work that would otherwise be performed

including services normally provided by temporary, part-time or seasonal workers or through contracting such services out; and

- d. result in the creation of jobs that are in addition to those that would be funded in the absence of assistance under the Act.

2. Funds under this Act shall supplement, and not supplant, the level of funds that would otherwise be made available from nonfederal sources for the planning and administration of programs.

N. Responsibilities of Service Delivery Area Grant Recipients and Subrecipients for Preventing Fraud and Program Abuse and for General Program Management General Requirements. Each service delivery area grant recipient and subrecipients shall establish and use internal program management procedures sufficient to prevent fraud and program abuse.

AUTHORITY NOTE: Promulgated in accordance with R.S. 23:2022.

HISTORICAL NOTE: Promulgated by the Department of Labor, Office of Labor, LR 9:335 (May 1983), amended LR 13:360 (June 1987), amended by the Department of Employment and Training, Office of Labor, LR 17:357 (April 1991), amended by the Department of Labor, Office of Labor, LR 19:1590 (December 1993).

### §165. Governor's Responsibility

A. The governor or his designee reserves the right to issue directives, instructions, or other issuances to the Service Delivery Area (SDA) grant recipients, administrative entities and other subrecipients in order to carry out his responsibility as required by the Act.

AUTHORITY NOTE: Promulgated in accordance with R.S. 23:2022.

HISTORICAL NOTE: Promulgated by the Department of Labor, Office of Labor, LR 10:546 (July 1984), amended by the Department of Employment and Training, Office of Labor, LR 17:357 (April 1991), repromulgated by the Department of Labor, Office of Labor, LR 19:1592 (December 1993).

### §167. CETA Property

A. All existing nonexpendable Comprehensive Employment and Training Act (CETA) property with an acquisition cost of less than \$1,000 per unit may be used by the possessing recipient, SDA grant recipient, administrative entity, or state agency holding title, to satisfy the matching requirements of the Act in accordance with the definition of *Matching Funds for Eight Percent Programs* found in §101 of these rules.

AUTHORITY NOTE: Promulgated in accordance with R.S. 23:2022.

HISTORICAL NOTE: Promulgated by the Department of Labor, Office of Labor, LR 10:546 (July 1984), amended by the Department of Employment and Training, Office of Labor, LR 17:357 (April 1991), amended by the Department of Labor, Office of Labor, LR 19:1592 (December 1993).

### §169. Occupational Demand

A. Except as otherwise provided, training provided with funds made available under this Act shall be only for

occupations for which there is a demand in the area served, or in other areas to which the participant is willing to relocate.

B. All contracts that are being funded by JTPA money where the intent of the contract is placement shall have performance goals including placement goals incorporated in that contract unless otherwise specified by the council.

AUTHORITY NOTE: Promulgated in accordance with R.S. 23:2022.

HISTORICAL NOTE: Promulgated by the Department of Labor, Office of Labor, LR 10:917 (November 1984), amended by the Department of Employment and Training, Office of Labor, LR 17:357 (April 1991), repromulgated by the Department of Labor, Office of Labor, LR 19:1592 (December 1993).

### **§171. Labor Organizations**

A. Where a labor organization represents a substantial number of employees who are engaged in similar work or training in the same area as that proposed to be funded under this Act, an opportunity shall be provided for such organization to submit comments with respect to such proposals.

AUTHORITY NOTE: Promulgated in accordance with R.S. 23:2022.

HISTORICAL NOTE: Promulgated by the Department of Labor, Office of Labor, LR 10:917 (November 1984), amended by

the Department of Employment and Training, Office of Labor, LR 17:357 (April 1991), amended by the Department of Labor, Office of Labor, LR 19:1592 (December 1993).

### **§173. Deadlines**

A. Not less than 120 days before the beginning of the first of the two program years covered by the JTPA Plan:

1. the proposed plan or summary thereof shall be published; and

2. such plan shall be made available for review and comment to:

a. each house of the legislature;

b. local educational and public agencies; and

c. the labor organization in the area which represents employees having the skills in which training is proposed.

AUTHORITY NOTE: Promulgated in accordance with R.S. 23:2022.

HISTORICAL NOTE: Promulgated by the Department of Labor, Office of Labor, LR 10:917 (November 1984), amended by the Department of Employment and Training, Office of Labor, LR 17:357 (April 1991), amended by the Department of Labor, Office of Labor, LR 19:1593 (December 1993).



**Title 40**  
**LABOR AND EMPLOYMENT**  
**Part XV. Private Employment Services**

**Chapter 1. General Provisions**

**§101. Definitions**

*Employment Service Manager*—an individual designated by the employment service to conduct the general management, administration and operation of a specified private employment service (PES) office.

*On-Site Consultant*—an individual designated by the employment service, to conduct the general management, administration and operation of a specified private employment service (PES) office, but does not carry the title of manager.

AUTHORITY NOTE: Promulgated in accordance with R.S. 23:112.

HISTORICAL NOTE: Promulgated by the Department of Labor, Office of Labor, LR 7:630 (December 1981), amended by the Department of Employment and Training, Office of Labor, LR 17:357 (April 1991), amended by the Department of Labor, Office of Regulatory Services, LR 28:511 (March 2002).

**§103. Operational Mandates**

A. A licensee must file with the assistant secretary a bond written by a surety company authorized to do business in this state for each licensed office in the sum of \$5,000. The beneficiary of said bond shall be the assistant secretary. An approved bond form (OOL-2) must be executed by the surety company in accordance with data requested on said form and the dates of the bond must coincide with the inclusive dates of the license. Only original bonds containing surety seal will be accepted.

B. A licensee must furnish the Office of Regulatory Services with its business telephone number.

C. A licensee shall at all times conspicuously post, in the main receiving area of his/her office, the current "original" private employment service license to operate.

D. A licensee shall at all times conspicuously post, in the main receiving area of his/her office, a current copy of his/her approved applicant schedule of fees printed in not less than 30-point bold face type.

E. A licensee shall at all times conspicuously post, in the main receiving area of his/her office, a notice stating that copies of the *Rules and Regulations Governing Private Employment Services* and any supplement thereto are available for inspection upon request.

F. Each licensed service must have an individual designated as the on-site manager for that location, or an on-site consultant who has been tested. No individual may be designated as a private employment service manager at more than one location. Each manager and/or on-site consultant

shall have successfully passed the private employment service examination.

G. A licensee shall agree to make all records and data pertinent to placement, available to any Office of Regulatory Services Compliance Officers or officials upon request.

H. Prior to sending an applicant on a job interview, the employment service must have a job order from the employer granting permission to the service to submit applicants for a fee, if hired. Each job order must contain the following:

1. date;
2. employer name and address;
3. position description; and
4. approximate salary.

I. Individual documentation must be executed on each interview referral.

J. Any amended fee schedule must be filed with and approved by the assistant secretary or his designee.

AUTHORITY NOTE: Promulgated in accordance with R.S. 23:112.

HISTORICAL NOTE: Promulgated by the Department of Labor, Office of Labor, LR 7:630 (December 1981), amended by the Department of Employment and Training, Office of Labor, LR 17:357 (April 1991), amended by the Department of Labor, Office of Regulatory Services, LR 28:511 (March 2002).

**§107. Prohibited Conduct**

A. No employment service, employment service manager, and/or consultant shall engage in the following conduct:

1. advertise or use letterheads, receipts, or other written or printed matter unless such materials contain the name of the employment service, as registered with and licensed by the assistant secretary;
2. require an applicant placed in an employer-fee-paid position to pay a fee of any kind;
3. permit an applicant to sign a power of attorney, promissory note, negotiable instrument, or assignment of wages in an amount exceeding the approved and posted fee;
4. no employment service licensee, manager or consultant shall use an alias or any other name in the course and scope of their employment other than their legal name, unless registered with the Office of Regulatory Services within 30 days from the effective date of these rules. No such request for registration received after 30 days from the effective date of these rules will be considered;

5. charge or receive a fee from an applicant prior to the actual commencement of work on a job procured by the employment service, manager, or consultant, except that where an employed applicant accepts new employment after having signed a contract but fails to report to work on the new job and instead remains with his present employer, a fee not to exceed 20 percent of the fee for permanent employment on the new job may be charged;

6. other than as described in §107.A.5 hereinabove, an employment service shall not receive a fee from an applicant who does not commence work on a job procured by the employment service.

AUTHORITY NOTE: Promulgated in accordance with R.S. 23:112.

HISTORICAL NOTE: Promulgated by the Department of Labor, Office of Labor, LR 7:630 (December 1981), amended by the Department of Employment and Training, Office of Labor, LR 17:357 (April 1991), amended by the Department of Labor, Office of Regulatory Services, LR 28:512 (March 2002).

**§109. Application for License**

**A. Initial License**

**1. Forms Required to be Completed and Submitted**

a. OOL-1 Application. The facts specified in the application must be sworn and attested before a notary. All applications must be signed by the proposed licensee.

b. OOL-2 Bond Form. In the amount of \$5,000 executed by a surety company licensed and authorized to do business in Louisiana. Each bond must bear a surety seal and contain licensee's name, private employment service business name, trade names, if applicable and physical location.

c. Corporations shall submit a certified copy of the Articles of Incorporation, which contains the gold seal from the Louisiana Office of Secretary of State.

d. Corporations registered outside of Louisiana must furnish an original certificate of authority to operate in Louisiana, which certificate is issued by the Louisiana Office of Secretary of State.

e. Partnerships shall submit a certified copy of the Articles of Partnership, which contains the gold seal from the Louisiana Office of Secretary of State. Licensee's name must be listed in the Articles of Partnership.

**2. Additional Requirements**

a. Three notarized statements from character references.

b. The proposed applicant's contract must be submitted and approved by the assistant secretary.

c. Licensees, managers, and/or on-site consultants must pass a written examination, administered by the Office of Regulatory Services, with a score of at least 80 percent.

d. Each proposed licensee must submit a resume detailing his/her business involvement during the preceding 10 years.

e. Each proposed licensee must submit a letter stating whether or not he/she has ever been convicted of a felony or misdemeanor. If he/she has been convicted, full particulars must be given including the offense, the date, the sentence and the court in which the proceeding occurred.

f. A license shall be required for each employment service operated or advertised.

g. Each licensee shall pay a \$300 investigation fee.

h. Services that are "Exclusively Employer Fee Paid" shall submit a notarized statement attesting to same.

i. License fee shall be \$200 per year for each location.

j. License fee for an out-of-state employment service which merely advertises in the state shall be the same as the fee for employment services located in Louisiana.

k. Every license issued shall remain in force until December 31 of year of issuance, unless such license has been revoked pursuant to the provisions of this law or the licensee submit a notarized request to cancel the license.

l. Each corporation must designate an individual, to be tested and to be the licensee. If the licensee leaves the corporation, it must designate a new individual to be licensed. If designated individual is not listed in the Articles of Incorporation, the board of directors must furnish a notarized letter attesting to the designated individual's position within the corporation or file an amendment to the articles.

m. Each partnership must designate at least one partner to be tested and to be the licensee. If the licensee leaves the partnership it must designate a new individual to be licensed. If designated partner is not listed in the Articles of Partnership, an amendment to the Articles of Partnership must be filed listing that individual's name.

**B. Renewal Licenses**

**1. Forms required to be completed and submitted:**

a. OOL-1 Renewal Application;

b. OOL-2 Bond Form (original only) executed by Surety Company or Continuation Certificate, (original only) from surety company, the period of coverage must correspond with the license year. Said bond form or continuation certificate must contain licensee's name, private employment service business name, trade name, if applicable and physical location;

c. beginning date of bond or continuation certificate must be January 1 of license year and expiration must be through December 31, of license year.

**2. Additional Requirements**

a. Licensees must submit their applicant contract for approval.

b. Services that are "Exclusively Employer Fee Paid" shall submit a statement affirming same.



c. Application for renewal must be received by the Office of Regulatory Services no later than the last business day of the calendar year for which the current license was issued.

d. The failure of any licensee who fails to timely renew a license shall require that the employment service office be closed.

e. Renewal fee shall be \$200 per year for each office location.

AUTHORITY NOTE: Promulgated in accordance with R.S. 23:112.

HISTORICAL NOTE: Promulgated by the Department of Labor, Office of Labor, LR 7:630 (December 1981), amended by the Department of Employment and Training, Office of Labor, LR 17:357 (April 1991), amended by the Department of Labor, Office of Regulatory Services, LR 28:512 (March 2002).

**§111. Reporting Requirements**

**A. Address Change**

1. Any change in a licensed employment service's physical location must be reported in writing to the Office of Regulatory Services by the licensee(s) at least two weeks prior to such change.

2. A rider (original only) from the surety company affecting the new address must be submitted to the Office of Regulatory Services prior to such change.

3. Licensee(s) shall return to the Office of Regulatory Services the current original license for reissuance of updated address.

**B. Closure of Employment Service**

1. Licensee(s) shall notify the Office of Regulatory Services, in writing immediately upon closing an employment service location.

2. Licensee(s) shall return to the Office of Regulatory Services the current original license for proper cancellation.

**C. Change of Ownership**

1. Licensee(s) shall notify the Office of Regulatory Services of any change in ownership of employment service immediately. Such notification must be received 14 days prior to the actual sale.

2. Licensee(s) shall return current original license to the Office of Regulatory Services for proper cancellation.

3. Licensee(s) shall inform the Office of Regulatory Services of proposed new owner/owners' name(s) and address(es).

D. A private employment service license is not transferable and it will not authorize any individual other than the individual to whom it is issued, nor any place or business transacted under any name, nor physical location, other than that designated in the license.

**E. Change of Licensed Business Name**

1. Licensee(s) must notify the Office of Regulatory Services, in writing, when changing licensed business name, prior to name change.

2. Licensee(s) must furnish the Office of Regulatory Services, a rider (original) from the surety company covering the new name.

3. Licensee(s) shall return to the Office of Regulatory Services the current original license for reissuance of updated business name.

F. The Office of Regulatory Services will not license services with deceptively similar names.

**G. Change of Manager or On-Site Consultant**

1. Licensee (s) must notify the Office of Regulatory Services in writing, immediately when changing manager or on-site consultant.

2. Licensee (s) shall furnish the Office of Regulatory Services with new manager's and/or on-site consultant's name.

3. Licensee(s) shall send \$100 fee for each exam administered.

AUTHORITY NOTE: Promulgated in accordance with R.S. 23:112.

HISTORICAL NOTE: Promulgated by the Department of Labor, Office of Labor, LR 7:630 (December 1981), amended by the Department of Employment and Training, Office of Labor, LR 17:357 (April 1991), amended by the Department of Labor, Office of Regulatory Services, LR 28:513 (March 2002).

**§113. Examinations**

A. Each individual named as a private employment service licensee, and each individual named as a private employment service manager and each individual named as an on-site consultant, shall demonstrate sufficient knowledge of the private employment service law, rules and regulations by scoring at least 80 percent on a written examination.

B. The private employment service examination will be developed, administered and scored by the Assistant Secretary, Office of Regulatory Services, or his designee.

C. Each individual to whom the private employment service examination is administered shall pay to the assistant secretary a fee of \$100, which shall not be refundable under any circumstance.

D. Examinations will be given within 10 days from the date of request and may be administered at the Office of Regulatory Services' Administrative Office, Baton Rouge, Louisiana, or at any Office of Regulatory Services Field Office at the convenience of the party being tested.

E. Test results will be provided on the same day that the completed examination is received by the Private Employment Service Program Compliance Officer Supervisor for scoring.

AUTHORITY NOTE: Promulgated in accordance with R.S. 23:112.

**LABOR AND EMPLOYMENT**

HISTORICAL NOTE: Promulgated by the Department of Labor, Office of Labor, LR 7:630 (December 1981), amended by the Department of Employment and Training, Office of Labor, LR 17:357 (April 1991), amended by the Department of Labor, Office of Regulatory Services, LR 28:513 (March 2002).

**§115. Fees for Placement**

**A. Résumé Preparation**

1. An employment service may prepare an applicant's job résumé upon applicant's request at a cost not to exceed the fee set in R.S. 23:111.B.(1)(b). The employment service shall furnish the applicant with a copy of the prepared résumé at no additional cost.

AUTHORITY NOTE: Promulgated in accordance with R.S. 23:112.

HISTORICAL NOTE: Promulgated by the Department of Labor, Office of Labor, LR 7:630 (December 1981), amended by the Department of Employment and Training, Office of Labor, LR 17:357 (April 1991), amended by the Department of Labor, Office of Regulatory Services, LR 28:514 (March 2002).

**§117. Investigations**

A. The assistant secretary, upon receipt of a complaint or upon his own motion may initiate an investigation into any alleged violations of the Employment Service Law or of these rules and regulations promulgated thereunder.

AUTHORITY NOTE: Promulgated in accordance with R.S. 23:112.

HISTORICAL NOTE: Promulgated by the Department of Labor, Office of Labor, LR 7:630 (December 1981), amended by the Department of Employment and Training, Office of Labor, LR 17:357 (April 1991), amended by the Department of Labor, Office of Regulatory Services, LR 28:514 (March 2002).

**§119. Revocation**

A. No new license shall be issued to any individual whose prior license has been revoked until the expiration of at least two years, and then only upon a proper showing that the reasons for the revocation have been corrected, that all other requirements for a license have been met, that the necessary examinations have been taken and passed, and that all fees have been paid. The burden of proof shall be on the applicant.

AUTHORITY NOTE: Promulgated in accordance with R.S. 23:112.

HISTORICAL NOTE: Promulgated by the Department of Labor, Office of Labor, LR 7:630 (December 1981), amended by the Department of Employment and Training, Office of Labor, LR 17:357 (April 1991), amended by the Department of Labor, Office of Regulatory Services, LR 28:514 (March 2002).

**§123. Private Employment Services Contract**

**A. Applicant Contract** Date: \_\_\_\_\_

1. This contract is entered into by and between \_\_\_\_\_, hereinafter referred to as the applicant and, hereinafter referred to as the Employment Service.

2. Should applicant accept employment with an employer or subsidiary to which the employment service has referred within 12 months from date of referral, applicant agrees to pay for professional services in accordance with

the schedule contained in Paragraph 5. This contract is valid for a period of one year from the above date or can be terminated by either party at any time by written notice, but not to the detriment of any legal rights or obligations incurred prior to such termination.

3. Acceptance means agreement by applicant with an employer to begin work.

4. Schedule of Fees (Rate of Professional Service Charges Based on Projected Annual Compensation at Time of Acceptance). The method of computing applicant's projected annual compensation, shall be 52 times applicant's weekly compensation, or 12 times applicant's monthly compensation or as outlined in Paragraph 7 of this contract. These estimates are for the purpose of computing service charges and in no way guarantee the procured employment for a year.

**5. Schedule of Fees**

<b>Estimated Gross Annual Compensation</b>	
<b>Maximum Fee</b>	
Less than \$ 4,000	4%
\$4,000 but less than \$ 5,000	5%
\$5,000 but less than \$6,000	6%
\$6,000 but less than \$ 7,000	7%
\$7,000 but less than \$ 8,000	8%
\$8,000 but less than \$ 9,000	9%
\$9,000 but less than \$10,000	10%
\$10,000 but less than \$11,000	11%
\$11,000 but less than \$12,000	12%
\$12,000 but less than \$13,000	13%
\$13,000 but less than \$14,000	14%
\$14,000 but less than \$15,000	15%
\$15,000 but less than \$16,000	16%
\$16,000 but less than \$17,000	17%
\$17,000 but less than \$18,000	18%
\$18,000 but less than \$19,000	19%
\$19,000 but less than \$20,000	20%
\$20,000 but less than \$21,000	21%
\$21,000 but less than \$22,000	22%
\$22,000 but less than \$23,000	23%
\$23,000 but less than \$24,000	24%
\$24,000 but less than \$25,000	25%
\$25,000 and up shall never exceed	25%

Fees are rounded down to the nearest dollar.

6. It is agreed that applicant shall at all times have the right to refuse any employment tendered. The fee of the employment service is earned when applicant accepts employment, payable as follows except that in no case shall any portion of the fee be collected before the applicant commences work on the new job and in no case shall the full amount of the fee be mandatorily payable sooner than 30 days from the date employment begins.

**Guarantee**

If the position the employment service has obtained for applicant ends within 90 consecutive calendar days from date of employment, regardless of reason, the service charge will be reduced to 20 percent of the gross earnings of the applicant. All refunds due shall be made promptly by the employment service upon proper verification of earnings with the employer, and in no case shall the delay exceed 14 days from date verification in writing is received. The applicant shall be responsible for obtaining verification of earnings from employer. If applicant accepts a position and then remains

with his present employer, he agrees to pay 20 percent of the applicable fee for the position accepted.

7. If applicant accepts a job where he/she is compensated on a straight commission, drawing account, salary plus bonus or any combination of these, he/she agrees that the employment service fee shall be based on his/her first full year's gross compensation as estimated by the employer. The fee shall be adjusted downwards or upward accordingly at the end of the first full year of employment based upon proof of actual compensation. Requests for adjustment must be made by either party in writing within 60 days following the first full year of employment or termination, whichever is sooner. Under no circumstances will overtime pay be included in gross earnings.

8. Applicant's acceptance of an introduction by the employment service shall take precedence over any previous application he may have filed with said employer.

9. Applicant hereby stipulates and agrees to pay a penalty of 25 percent as attorney fees, plus court cost, on the earned fees due the employment service should it become necessary for the service to obtain counsel, a collection service, or resort to court action to collect same.

10. Applicant hereby stipulates that any agreement regarding the reimbursement of the service charge to applicant by the employer, is a separate agreement between said employer and applicant. Applicant further stipulates that regardless of any such agreement, applicant is responsible for the service charge under the conditions and terms of the contract.

11. It is understood that if any section of this contract is in conflict with the Louisiana Private Employment Service Law or the rules and regulations established thereunder, then the provisions of law, rule and regulations shall govern. The declaration that any section of this contract conflicts with the provisions of law shall not render the remainder of this contract null, and to that end the sections of this contract are declared severable.

12. The employment service agrees that it will not under any interpretation of this contract make more than one full service charge for any one placement.

13. The parties hereto acknowledge receipt of a copy of this contract; that they have read and understand all provisions thereof and agree to abide by its terms and conditions.

APPLICANT: \_\_\_\_\_  
DATE: \_\_\_\_\_  
BY: \_\_\_\_\_  
PES REPRESENTATIVE: \_\_\_\_\_

AUTHORITY NOTE: Promulgated in accordance with R.S. 23:112.

HISTORICAL NOTE: Promulgated by the Department of Labor, Office of Labor, LR 7:631 (December 1981), amended LR 14:231 (April 1988), amended by the Department of Employment and Training, Office of Labor, LR 17:357 (April 1991), amended by the Department of Labor, Office of Regulatory Services LR 28:514 (March 2002).

**§125. Private Employee Service Contract for Sitters/Nurses**

**A. PES Contract**

1. This agreement entered into this date \_\_\_\_\_ between \_\_\_\_\_ hereinafter referred to as REGISTER and \_\_\_\_\_ hereinafter referred to as the applicant. Should I accept employment with an employer to which \_\_\_\_\_ has referred me within 12 months from date of referral, I agree to pay a fee for professional services in accordance with the fee schedule listed in Paragraph 3.

2. This contract is valid for a period of one year from the above date or may be terminated by either party at any time by written notice, but not to the detriment of any legal rights or obligations incurred prior to such termination.

3. The applicant agrees to pay to \_\_\_\_\_ a fee of \_\_\_\_\_ percent of first year's gross earnings received for employment to which \_\_\_\_\_ has referred the applicant. Should case continue longer than one year, no additional fee will be charged.

4. Applicant hereby agrees to pay a penalty of 25 percent as attorney fees, plus court cost, on the earned fees due \_\_\_\_\_ should it become necessary to obtain counsel, a collection service, or resort to court action.

5. Applicant hereto acknowledges receipt of a copy of this contract; and understands the foregoing contract and agree to all of its terms and conditions.

\_\_\_\_\_  
APPLICANT  
\_\_\_\_\_  
DATE  
\_\_\_\_\_  
REPRESENTATIVE  
\_\_\_\_\_  
DATE

AUTHORITY NOTE: Promulgated in accordance with R.S. 23:112.

HISTORICAL NOTE: Promulgated by the Department of Labor, Office of Labor, LR 7:630 (December 1981), amended by the Department of Employment and Training, Office of Labor, LR 17:357 (April 1991), amended by the Department of Labor, Office of Regulatory Services, LR 28:515 (March 2002).

**§127. Private Employment Services Contract for Applicant Escrow Account**

**A. Private Employment Services Contract**

1. This contract is entered into by and between \_\_\_\_\_ hereinafter referred to as the applicant and (name of private employment service) hereinafter referred to as the employment service. Acceptance means agreement by applicant with employer to begin work.

2. Should applicant accept employment with an employer to which the employment service has referred him/her within one year from the date of this contract, the applicant agrees to pay a fee for professional services

LABOR AND EMPLOYMENT

rendered in accordance with the schedule contained in Paragraph 4. This contract can be terminated by either party at any time by written notice, but not to the detriment of any legal rights or obligations incurred prior to such termination.

3. Applicant hereby agrees to execute a payroll check mailing agreement and a limited power of attorney authorizing the employment service to receive applicant's payroll checks, pay to itself the applicable placement fee and remit the remainder of wages to applicant as spelled out in the limited power of attorney.

4. The professional service placement fee shall be based on the applicant's projected daily wage rate, multiplied times \_\_\_\_ days.

5. Upon acceptance of a job, the employment service shall prepare an invoice which states the actual placement fee and place the invoice in the applicant's file. The placement fee shall be paid in strict accordance with terms of the limited power of attorney alluded to above and all files concerning the placement fee, limited power of attorney and mailing agreement shall be maintained in the applicant's file for a period of five years after the aforementioned power of attorney expires.

6. The estimates of applicant's daily wage rate found herein are for the purpose of computing service charge and in no way guarantee the procured employment for a year. The fee is earned by employment service when applicant accepts employment and is payable as follows.

a. No down payment is required! Payments will be 20 percent of gross pay of each payroll check until fee has been paid in its entirety.

Guarantee

If position employment service has obtained for applicant ends within 90 days from date of employment, regardless of reason, the service charge will be reduced to 20 percent of gross earnings of applicant. All refunds due shall be made promptly by employment service upon proper verification of earnings with employer, and in no case shall the delay exceed 14 days from applicant's request. If applicant accepts a position and then remains with his present employer, he agrees to pay 20 percent of the applicable fee for position accepted.

7. Applicant hereby stipulates and agrees to pay a penalty of 25 percent as attorney fees, plus court cost, on the earned fees due the employment service should it become

necessary for the service to obtain counsel, a collection service, or resort to court action to collect same.

8. It is understood that if any section of this contract is in conflict with Louisiana Private Employment Service Law, or the rules and regulations established thereunder, then the provisions of law, rule and regulations shall govern. The declaration that any section of this contract conflicts with the provisions of law shall not render the remainder of this contract null, and to that end the sections of this contract are declared severable.

9. (Name of Private Employment Service) agrees that it will not under any interpretation of this contract make more than one service charge for any one placement. The parties hereto acknowledge receipt of a copy of this contract; they have read and understand all provisions thereof and agree to abide by its terms and conditions.

\_\_\_\_\_  
SIGNATURE OF APPLICANT

\_\_\_\_\_  
DATE

\_\_\_\_\_  
SOCIAL SECURITY #

\_\_\_\_\_  
SIGNATURE OF PES REPRESENTATIVE

AUTHORITY NOTE: Promulgated in accordance with R.S. 23:112.

HISTORICAL NOTE: Promulgated by the Department of Labor, Office of Labor, LR 7:630 (December 1981), amended by the Department of Employment and Training, Office of Labor, LR 17:357 (April 1991), amended by the Department of Labor, Office of Regulatory Services, LR 28:515 (March 2002).

**§129. Severability Clause**

A. These rules and each of their provisions are hereby declared to be severable, one from another. If any provision or item of a rule, or the application thereof, is held invalid, such invalidity shall not affect other provisions, items, or applications of the rule which can be given effect without the invalid provision, item or application.

AUTHORITY NOTE: Promulgated in accordance with R.S. 23:112.

HISTORICAL NOTE: Promulgated by the Department of Labor, Office of Regulatory Services, LR 28:515 (March 2002).

**Title 40**  
**LABOR AND EMPLOYMENT**  
**Part XVI. Customized Training**

**Chapter 1. Workforce Development  
Training Fund**

**§101. Definitions**

*Account*—the Workforce Development Training Account.

*Applicant*—the business requesting training assistance from LDOL under this program, including a registered joint labor and employer group-administered apprenticeship program under §103.A.4.

*Award*—funding approved under this program for eligible training activities.

*Awardee*—an applicant (and/or company(ies)) receiving a training award under this program.

*Contract*—a legally enforceable agreement between LDOL, the applicant and a training provider governing the terms and conditions of the training award.

*Contractee*—the applicant and training provider that are party to a training award contract with LDOL under this program.

*Incumbent Worker*—a worker who is currently on the payroll of the applicant.

*Individual Standardized Training*—off-the-shelf training that is not customized to the needs of the individual applicant and that is currently offered by a training provider at the time the application is filed with LDOL; to be provided through the Small Business Employee Training Program and to be administered in accordance with §113.

*LDOL*—the Louisiana Department of Labor.

*Monitoring Entity*—a public or private entity contracted or selected to monitor the compliance of a contractee with the terms and conditions of a training award contract.

*Secretary*—the Secretary of the Department of Labor.

*Supplant*—diversion of normal training funding for other uses simply because training funds are awarded under the Incumbent Worker Training Program.

*Training Provider*—the entity providing the customized training for the awardee.

AUTHORITY NOTE: Promulgated in accordance with R.S. 23:1514.

HISTORICAL NOTE: Promulgated by the Department of Labor, Office of Workforce Development, LR 25:1142 (June 1999), amended LR 26:1629 (August 2000), LR 29:2497 (November 2003), amended by the Department of Labor, Office of the Secretary, LR 30:2329 (October 2004).

**§103. Eligibility**

A. An applicant shall be eligible for customized training if it is one of the following:

1. an individual employer that seeks to provide customized training for his incumbent workers to prevent job loss caused by obsolete skills, technological change, or national or global competition;

2. an individual employer that seeks to provide customized training for its incumbent workers to create, update, or retain jobs in a labor demand occupation;

3. an individual employer that seeks to provide customized training for its incumbent workers to update or retain jobs in an occupation which is not a labor demand occupation, if the administrator determines that the services are necessary to prevent the likely loss of jobs;

4. a labor or community-based organization that seeks to provide customized training for a labor demand occupation for workers who are incumbent to an industry, were attached to a contributing employer within the last 12 months, and are not receiving unemployment insurance benefits at time of training;

5. a consortium made up of one or more educational institutions and one or more eligible individual employers, labor, or community-based organizations that seeks to provide customized training for incumbent workers in labor demand occupations;

6. a local economic development entity and one or more eligible individual employers that seek to provide customized training for incumbent workers in a labor demand occupation.

B. Qualified businesses currently receiving training for their employees may, upon the expiration of contracts, apply for new training grants for training of new employees, previously untrained employees, or for additional training of previously trained employees.

C. All applications by eligible applicants for customized training shall be submitted in conjunction with the entity selected by the applicant to provide the customized training. All disbursements of funds for the training shall be made to the entity actually providing the customized training. To be eligible, the training provider selected by the applicant must demonstrate a history of:

1. successful training through its placement, retention, and satisfaction rates;

2. collaboration with the targeted industry in the development of the training program curriculum;

3. use of a current industry standard as the basis for programs utilized to train students for employment in the targeted industry.

AUTHORITY NOTE: Promulgated in accordance with R.S. 23:1514.

HISTORICAL NOTE: Promulgated by the Department of Labor, Office of Workforce Development, LR 25:1142 (June 1999), amended LR 29:2498 (November 2003).

**§105. Criteria**

A. Employer(s) must have been in business in the state for at least three years, contributing to the workforce development training account, and be in full compliance with Louisiana unemployment insurance laws. In the case of a buyout or merger, LDOL will use data from the Tax Operations Unit of the Office of Regulatory Services to determine whether or not an applicant will be allowed to carry over operation time of a previous entity.

B. No single employer or consortium shall receive more than 10 percent of the total funds available to the program during a fiscal year. An employer with multiple operations sites and a single unemployment insurance tax identification number shall be limited to a single application which may encompass training at the various sites, so long as the amount awarded under the application does not exceed the maximum award amount. When an employer has more than one site and each site maintains a different unemployment insurance tax identification number, the employer may apply for a separate training awarded under each tax identification number.

C. Employers receiving awards must provide evidence satisfactory to LDOL of their long-range commitment to employee training and that funds shall be used to supplement and not supplant existing training efforts.

D. Applicants must request training for at least 15 employees and where applicable, the training provided must meet, at the minimum, the safety standards determined by OSHA.

E. Special emphasis shall be placed on entry level/incumbent training programs.

F. Preference will be given to employers that have:

1. selected a public training institution as the training provider;
2. donated materials, equipment, or instructors to public training providers, secondary and postsecondary vocational-technical schools, or community colleges within the state;
3. hired recent recipients of public assistance such as JTPA/WIA, unemployment benefits, FITAP, and rehabilitative services;
4. hired individuals recently released from a correctional facility;
5. participated in a workplace safety consultation with employees of the Office of Workers' Compensation Administration;

6. listed job openings with LDOL;
7. never received a training award under this program.

G. Employers seeking a training award may not select as a training provider:

1. any entity whose principal owner is an immediate family member, as defined in the Code of Governmental Ethics, of an individual in a management position with the employer who has the authority to make decisions regarding the training program; or
2. any related business such as a parent, subsidiary, or partner of the employer.

H. Nothing contained herein shall prohibit the selection of a training proprietary school or private institution as a training provider.

AUTHORITY NOTE: Promulgated in accordance with R.S. 23:1514.

HISTORICAL NOTE: Promulgated by the Louisiana Department of Labor, Office of Workforce Development, LR 25:1143 (June 1999), amended LR 26:1629 (August 2000), LR 28:2203 (October 2002), LR 29:2498 (November 2003), amended by the Department of Labor, Office of the Secretary, LR 30:2329 (October 2004).

**§107. Application Procedure**

A. LDOL will provide a standard form which applicants will use to apply for assistance. The application form will contain, but not be limited to, detailed descriptions of the following:

1. an overview of the company, its history, and the business climate in which it operates;
2. the company's overall training plan, including:
  - a. a summary of the types and amount of training currently provided by the company and a description of how the company determined its training needs; and
  - b. the specific training programs for which LDOL assistance is requested including descriptions of the training methods, the training providers, and the costs associated with the proposed training; and
3. any additional information the secretary may require.

AUTHORITY NOTE: Promulgated in accordance with R.S. 23:1514.

HISTORICAL NOTE: Promulgated by the Department of Labor, Office of Workforce Development, LR 25:1143 (June 1999), amended LR 26:1630 (August 2000).

**§109. Submission and Review Procedure**

A. Applicants must submit their completed application to LDOL. Submitted applications will be reviewed and evaluated by LDOL staff. All applications will be measured using a rating system as an evaluation tool that will enable LDOL staff to determine which applications should receive approval, be deferred to future funding cycles, or be denied outright. Input may be required from the applicant, other

divisions of the Department of Labor, and other state agencies as needed, in order to:

1. understand the labor market conditions the proposed training is seeking to mitigate;
2. evaluate the strategic importance of the proposed training to the economic well-being of the state and local communities;
3. determine whether the employer's specific needs are best met by training;
4. identify the availability of existing training programs which could be adapted to meet the employer's needs;
5. identify the resources the business can provide to support the training, including trainers, facilities, materials and equipment;
6. identify or develop appropriate curricula; and
7. determine the most cost effective approach to meet the employer's training needs.

B. If any applicant is submitting an application in conjunction with a private training provider, the applicant may be required to submit a cost/price/performance analysis on a form provided by LDOL at the time the application is submitted.

C.1. Upon determination that an application meets the eligibility criteria for this program and is deemed to be beneficial to the well-being of the state, LDOL staff will then make a recommendation to the secretary. The application will then be reviewed by and is subject to the approval of the secretary.

2. A copy of the application shall be sent to the executive director of the Louisiana Workforce Commission.

3. The secretary will issue a letter of commitment to the applicant within five working days of approving the application.

**AUTHORITY NOTE:** Promulgated in accordance with R.S. 23:1514.

**HISTORICAL NOTE:** Promulgated by the Louisiana Department of Labor, Office of Workforce Development, LR 25:1143 (June 1999), amended LR 26:1630 (August 2000), LR 29:2498 (November 2003), amended by the Department of Labor, Office of the Secretary, LR 30:2329 (October 2004).

### **§111. General Award Provisions**

#### **A. Award Contract**

1. A contract will be executed between LDOL, the applicant [and/or company(ies) receiving training] and the training provider. The contract will specify the performance objectives expected of the company(ies) and the training provider and the compliance requirements to be enforced in exchange for state assistance, including, but not limited to, time lines for job training.

2. The monitoring entity will monitor the progress of the training.

3. LDOL will reimburse the training provider from invoices submitted by the training provider on a form approved by LDOL and disburse funds from invoices or certificates of work completed.

4. The cost associated with the contract between the monitoring entity and the applicant will be considered part of the total training award, but will not exceed 5 percent of the award amount or \$10,000, whichever is less.

5. Funds may be used for training programs extending up to two years in duration, or up to three years upon approval of the secretary.

#### **B. Use of Funds**

1. The Louisiana Workforce Development Training Account offers financial assistance in the form of a grant for reimbursement of eligible training costs specified in the award agreement.

2. Eligible training costs may include, inter alia, the following:

a. instruction costs—wages for instructors and training coordinators employed by the applicant or training provider, Louisiana public and/or private school tuition, contracts for vendor trainers, training seminars;

b. travel costs (limited to 30 percent of the total training award)—travel for trainers and training coordinators (company and training provider), and travel for trainees; travel expenses reimbursable under this agreement will comply with State Travel Regulations, PPM 49;

c. materials and supplies costs—training texts and manuals, audio/visual materials, skills assessment (documents or services to determine training needs), raw materials (for manufacturing and new employee on-the-job training), Computer Based Training (CBT) software; and

d. other costs—facility rental associated with the training contract and fees or service costs incurred by the monitoring entity associated with the contract to monitor the training.

3. Training costs ineligible for reimbursement include:

a. trainee wages and fringe benefits;

b. non-consumable tangible property (e.g., equipment, calculators, furniture, classroom fixtures, non-Computer Based Training (CBT) software), unless such property will be owned by a public training provider at the conclusion of the training contract;

c. out-of-state, publicly supported and private schools;

d. employee handbooks;

e. scrap produced during training;

f. food, refreshments; and

g. awards.

#### **C. Conditions for Disbursement of Funds**

1. Funds will be available on a reimbursement basis following submission of original invoices to LDOL to the attention of the Incumbent Worker Training Program Manager, Office of Workforce Development by mail or hand delivery. Only funds spent on the project after the secretary signs the contract will be considered eligible for reimbursement. LDOL shall make a determination regarding an invoice within 15 working days after receipt of the invoice and will make payment within 15 working days of approval of said invoice. Certain invoices that need priority attention shall be clearly marked "priority" and LDOL shall make a good faith effort to expedite the processing of such invoices. Invoices regarding the purchase of equipment must be accompanied by documentation confirming delivery.

2. Invoices will be eligible for reimbursement at 100 percent of the total invoice amount until the sum of the disbursements under a contract are equal to 90 percent of the total grant award. After the applicant and the training provider have achieved 100 percent of their contracted performance objectives or have substantially complied with the terms of the contract as determined by the secretary, the remaining 10 percent of the grant award will be made available for reimbursement.

3. All disbursements of funds shall be made to the training provider actually providing the customized training.

#### D. Compliance Requirements

1. Training providers shall be required to complete quarterly reports describing progress toward the performance objectives specified in their contract with LDOL. Training providers shall also be responsible for providing documentation to LDOL on a quarterly basis regarding the satisfaction of the business receiving training under the contract.

2. In the event the applicant or training provider fails to meet its performance objectives specified in its contract with LDOL, LDOL shall retain the rights to withhold award funds, modify the terms and conditions of the award, and to reclaim disbursed funds from the applicant and/or training provider in an amount commensurate with the scope of the unmet performance objectives and the foregone benefits to the state.

3. In the event LDOL decides to withhold award funds, modify the terms and conditions of an award, or reclaim disbursed funds from the applicant and/or training provider, LDOL shall provide notice of such determination to the applicant and training provider within three working days of such decision.

a. The applicant or training provider may appeal an adverse decision made by LDOL by providing written notice of objection to the secretary within five working days of receipt of the adverse decision. If a request for an appeal is made, then the appellant shall submit documentation to support the appeal within 10 working days after forwarding notice of the appeal. The secretary shall review the evidence submitted and render a written decision within 20 working days after receiving notice of the appeal. If no appeal is filed

within the applicable time period, the decision of LDOL shall become final.

b. If after review of the appeal, the secretary renders a decision that is adverse to the appellant, then the matter shall be subject to review by the commissioner of administration pursuant to R.S. 39:1524 and 39:1525.

4. In the event the applicant or monitoring entity knowingly files a false statement in its application or in a progress report, the applicant or monitoring entity shall be guilty of the offense of filing false public records and shall be subject to the penalty provided for in R.S. 14:133.

5. LDOL shall retain the right to require and/or conduct financial and performance audits of a project, including all relevant records and documents of the applicant and the monitoring entity.

AUTHORITY NOTE: Promulgated in accordance with R.S. 23:1514.

HISTORICAL NOTE: Promulgated by the Department of Labor, Office of Workforce Development, LR 25:1143 (June 1999), amended LR 26:1630 (August 2000), amended by the Department of Labor, Office of the Secretary, LR 30:2330 (October 2004).

#### §113. Small Business Employee Training Program

A. For purposes of this Part, small business is defined as a Louisiana based business that has 50 or less employees and is an eligible applicant as outlined in §103.A. The applicant will be reimbursed for the eligible costs associated with the training once the training has been completed and proper documentation has been submitted to LDOL.

B. Applicant can not receive customized training and small business employee training concurrently.

C. The applicant must submit the Small Business Employee Training Program application and receive LDOL approval, in writing, prior to the start of any training.

D. Applicant must be current on all state UI tax obligations.

E. Trainees must be incumbent workers for whom the applicant incurs a state unemployment tax liability under R.S. Title 23, Chapter 11.

F. The request for training must be in a labor demand occupation as defined in the Workforce Investment Act of 1998 (WIA) or cluster based industry as defined in Vision 2020.

G. Small business training can consist of the following:

1. taking a class, either non-credit or credit, at an educational institution under the policy or direct management authority of the Board of Regents;

2. receiving training from a manufacturer or their representative within one year of the purchase of equipment valued at more than \$3,000 where the training is not otherwise incorporated into the purchase price of the equipment;

3. receiving training from a manufacturer or their representative in order to upgrade computer skills;



4. receiving training from a national, regional or state trade association, that offers an independently certified training curricula and testing, which can demonstrate a successful training history of at least five years.

H. The proposed training provider under Paragraph G.1 must be domiciled in Louisiana and contribute data to LOIS Scorecard as required by R.S. 23:75 which shows a demonstrated history of successful training in the particular instruction that will be given.

I. Training costs shall not exceed \$3,000 per trainee per fiscal year.

J. Training costs can be any of the following:

1. tuition;
2. required textbooks and manuals.

K. Training must be completed by the end of the state fiscal year (June 30) in which it was begun.

L. Upon completion of the training, the employer must submit invoices for training expenditures along with proof of payment, proof of completion from the training provider, as well as proof of a pay increase or wages that were paid for the training hours attended, all within 30 days of the completion of the training.

M. An application shall be deemed approved by LDOL upon written approval of the Secretary of Labor or their designee. A letter of approval shall be forwarded to the applicant within five working days of approval of the application.

N. The Small Business Employee Training Program shall be funded at 2.3 percent of all funds available for training.

AUTHORITY NOTE: Promulgated in accordance with R.S. 23:1514.

HISTORICAL NOTE: Promulgated by the Louisiana Department of Labor, Office of Workforce Development, LR 29:2499 (November 2003), amended by the Department of Labor, Office of the Secretary, LR 30:2330 (October 2004).



**Title 40**  
**LABOR AND EMPLOYMENT**  
**Part XVII. Community Services Block Grant**  
**Subpart 1. CSBG Policy Manual**

**Chapter 1. Allocation of Funds**

**§101. Method of Allocation**

A. Not less than 90 percent of the total funds appropriated for Louisiana shall be allocated to eligible entities in accordance with Section 675(c)(2)(A) of the CSBG Act and R.S. 23:65. The formula to be used for the allocation of funds shall be approved through a process which includes a public hearing(s) scheduled each fiscal year to determine the use and distribution of funds. The formula adopted and the identification of the data base used to allocate funds will be included in the Annual Statewide Community Services Block Grant Plan.

AUTHORITY NOTE: Promulgated in accordance with R.S. 23:66 et seq.

HISTORICAL NOTE: Promulgated by the Department of Employment and Training, Office of Labor, LR 16:204 (March 1990), amended LR 17:357 (April 1991), amended by the Department of Labor, Office of Labor, LR 21:1339 (December 1995).

**§103. Identification of Eligible Entities**

A. Those organizations which were designated as a Community Action Agency or a Community Action Program under the Economic Opportunity Act of 1964 for fiscal year 1981 are qualified recipients for 90 percent of funds under the Community Services Block Grant (CSBG) Act. Not more than 7 percent of these funds in each fiscal year may be used to designate other qualified community action agencies to serve areas not previously served by an existing eligible entity as defined by the Act.

B. If any geographic area of the state is not, or ceases to be served by an eligible entity, the governor may decide to serve the area by:

1. requesting an eligible entity which is located and provides services in an area contiguous to the new area to serve the new area;

2. if no eligible entity is located and provides services in an area contiguous to the new area, requesting the eligible entity located closest to the area to be served or an existing eligible entity serving an area within reasonable proximity of the new area to provide services in the new area; or

3. where no existing eligible entity requested to serve the new area decides to do so, designating an existing eligible entity, any organization which has a board meeting the requirements of Section 675(c)(3) or any political subdivision of the state to serve the new area shall qualify such organization as an eligible entity under this Act.

AUTHORITY NOTE: Promulgated in accordance with R.S. 23:66 et seq.

HISTORICAL NOTE: Promulgated by the Department of Employment and Training, Office of Labor, LR 16:204 (March 1990), amended LR 17:357 (April 1991), amended by the Department of Labor, Office of Labor, LR 21:1339 (December 1995).

**§105. Notification of Availability of Funds**

A. Within 30 days of receipt by the Department of Employment and Training from the federal agency of the amount of funds available, the Department of Employment and Training will notify those eligible agencies of the allocation by parishes.

AUTHORITY NOTE: Promulgated in accordance with R.S. 23:61 et seq.

HISTORICAL NOTE: Promulgated by the Department of Employment and Training, Office of Labor, LR 16:205 (March 1990), amended LR 17:357 (April 1991).

**Chapter 3. Subgrant Proposal for Eligible Entities**

**§301. Date of Submission**

A. Each eligible entity shall submit a subgrant proposal for the use of CSBG funds to the Department of Labor annually or as otherwise instructed by that department. The Department of Labor will issue written instructions on the due date for subgrant proposals.

AUTHORITY NOTE: Promulgated in accordance with R.S. 23:66 et seq.

HISTORICAL NOTE: Promulgated by the Department of Employment and Training, Office of Labor, LR 16:205 (March 1990), amended LR 17:357 (April 1991), amended by the Department of Labor, Office of Labor, LR 21:1339 (December 1995).

**§303. Content of Subgrant Proposal**

A. The subgrant proposal shall be prepared in the format prescribed by the Department of Labor, and shall include (but not be limited to) the following:

1. identification of the eligible entity, to include the corporate name, street address and contact person;

2. a complete budget, including a budget summary, spending plan and staffing plan; and

3. a complete description of the programmatic activities to be funded which must provide programs in accordance with the CSBG Act.

B. The forms for submission of the subgrant proposal will be provided by the Department of Labor, CSBG Unit.

**AUTHORITY NOTE:** Promulgated in accordance with R.S. 23:66 et seq.

**HISTORICAL NOTE:** Promulgated by the Department of Employment and Training, Office of Labor, LR 16:205 (March 1990), amended LR 17:357 (April 1991), amended by the Department of Labor, Office of Labor, LR 21:1339 (December 1995).

### **§305. Attachments to Subgrant Proposal**

A. Each proposal shall contain (but not be limited to) the following attachments:

1. a list of the current board of directors, providing the names, addresses and telephone numbers of board members; identification of the segment each board member represents and dates of the current and preceding terms of each board member;

2. special clauses and assurances; and

3. any other information determined to be necessary by the Department of Labor to meet state or federal requirements.

**AUTHORITY NOTE:** Promulgated in accordance with R.S. 23:66 et seq.

**HISTORICAL NOTE:** Promulgated by the Department of Employment and Training, Office of Labor, LR 16:205 (March 1990), amended LR 17:357 (April 1991), amended by the Department of Labor, Office of Labor, LR 21:1339 (December 1995).

### **§307. Review and Approval of Subgrant Proposal**

A. The CSBG Unit will review and provide any technical assistance necessary to make modifications to the subgrant proposal submitted to assure compliance with the CSBG Act.

B. The subgrant proposal submitted will be signed by the executive director or the person empowered to enter into a subgrant on behalf of the eligible entity.

C. If the subgrant proposal is modified it shall be returned to the eligible entity for review, concurrence and signature. The signed subgrant will be returned to the CSBG Unit within 15 days. If no modification is necessary, the original plan shall become the subgrant.

D. The subgrant will be forwarded to the Department of Labor signatory, with the recommendation that the subgrant be signed.

E. The Community Services Block Grant Section will distribute copies of the signed subgrant to the subgrantee and Director of Financial Management as soon as they are signed. Program activities can begin on or after the dates defined in the subgrant period of the subgrant document.

**AUTHORITY NOTE:** Promulgated in accordance with R.S. 23:61 et seq.

**HISTORICAL NOTE:** Promulgated by the Department of Employment and Training, Office of Labor, LR 16:205 (March 1990), amended LR 17:357 (April 1991), amended by the Department of Labor, Office of Labor, LR 21:1340 (December 1995).

## **Chapter 5. Application for Discretionary Funds**

### **§501. Who May Apply**

A. Any public or private nonprofit agency who has as its primary objective the elimination of poverty in the local area may submit a proposal for operating any program which meets the requirement of the Act. Proposals must be submitted to the Community Services Block Grant Section.

**AUTHORITY NOTE:** Promulgated in accordance with R.S. 23:61 et seq.

**HISTORICAL NOTE:** Promulgated by the Department of Employment and Training, Office of Labor, LR 16:205 (March 1990), amended LR 17:357 (April 1991).

### **§503. Requirement of Agency**

A. Any private not for profit agency applying for funds must be incorporated by the state of Louisiana and must provide a copy of the articles of incorporation with its application for funding.

**AUTHORITY NOTE:** Promulgated in accordance with R.S. 23:66 et seq.

**HISTORICAL NOTE:** Promulgated by the Department of Employment and Training, Office of Labor, LR 16:205 (March 1990), amended LR 17:357 (April 1991), amended by the Department of Labor, Office of Labor, LR 21:1340 (December 1995).

### **§505. Proposal**

A. The agency must submit a proposal to the Community Services Block Grant Section in the format developed for that purpose. The proposal must include:

1. a description of the organization and its purpose;
2. a justification of the need for the program, including the identity of the method used to survey the need;
3. a complete description of the services to be provided and the method of assuring the services are provided to the most needy in the area, the dates the program will begin and end, and the number of persons to be served;
4. an identification of the staff required to provide the services and a brief job description of each;
5. a complete line item budget for the funds required to operate the program; and
6. an identification of the contact person.

B. The proposal will be reviewed by the CSBG Section, and recommendations made to the Secretary of Employment and Training or designee. The decision to fund will be made by the Secretary of Employment and Training or designee, and written notification will be made.

C. A subgrant will be developed from the proposal, and returned to the agency for signature. The subgrant must be signed by the authorized representative of the agency and the Secretary of Employment and Training or designee prior to the beginning of any activity, unless written authorization has been received to operate programs prior to that date.

**AUTHORITY NOTE:** Promulgated in accordance with R.S. 23:61 et seq.

**HISTORICAL NOTE:** Promulgated by the Department of Employment and Training, Office of Labor, LR 16:206 (March 1990), amended LR 17:357 (April 1991).

## Chapter 7. Governing Boards

### §701. Requirements

A. Applicability. In order to initially receive 90 percent CSBG funds and to maintain eligibility for CSBG funding, private not for profit agencies must maintain a governing board; and public agencies must maintain an advisory board, which meets the requirements of the CSBG Act. A list of board members, the segment each represents, their mailing address, and their terms must be submitted with each application for CSBG funding. Each parish served with CSBG funds must have representatives on the board from each segment.

B. Size of Board. The board shall consist of not less than 15 nor more than 31 members which broadly represent the area served by the agency.

C. Structure of Board and Selection of Board Members for a Community Action Agency or Nonprofit Private Organization. The board shall be constituted to assurances that in the case of a community action agency or nonprofit private organization, each board will be selected by the community action agency or nonprofit private organization and constituted so as to assure that:

1. one third of the members of the board are elected public officials, currently holding office in the geographical area to be served by the community action agency, or their representatives, except that if the number of elected officials reasonably available and willing to serve is less than one-third of the membership of the board, membership on the board of appointed public officials may be counted in meeting such one-third requirements. Duly appointed members may designate an individual to represent them on the board by properly notifying the local community action agency of such delegation;

2. at least one third of the members of the governing board shall be individuals with low income who reside in the area to be served by the agency, or representatives of those individuals. Persons representing individuals with low income need not themselves have incomes below the level established by the Department of Labor for purposes of this Part; however these representatives must reside in the same geographical area as the individuals they represent and must be chosen in accordance with democratic selection procedures adequate to assure that they are representative of the poor in the area served. The board will devise the method utilized to select representatives of the poor and the method utilized will be subject to review and approval by the grantor; and

3. the remainder of the members of the board shall be officials or members, or their designees of public agencies, business, industry, labor, religious, welfare, education or other major groups and interests in the community.

D. Structure of Board and Selection of Board Members for a Public Organization. In the case of a public organization receiving CSBG funds, such organization shall either establish:

1. a board of which at least one third of the members are chosen in accordance with democratic selection procedures adequate to assure that they are representatives of the poor in the area served which is subject to the review and approval by the grantor; or

2. another mechanism specified by the grantor to assure low-income citizens' participation in the planning, administration, and evaluation of projects for which such organization has been funded; and

3. members who represent officials or members of business, industry, labor, religious, welfare, education, or other major groups or interests shall be selected to provide a broad base of community involvement and support, and should be selected from each parish served. Organizations that are to have membership on the board must be selected by the board of directors, unless the selection process is changed by state or federal legislation.

### E. Bylaws

1. The board shall adopt bylaws which include the length of service of its members the allowability of alternates, and the responsibilities of the board. These bylaws shall be available for review by the Department of Labor.

2. The terms of the board members representing the elected public officials segment of the board shall coincide with their terms of elective office. The terms of all other board members shall not exceed five years and they shall serve no more than two consecutive terms without serving an inactive year.

3. The governing board of a community action agency or private nonprofit organization shall have the power to appoint a person to the senior staff position; to determine fiscal and program policies; to approve all rules and procedure; and to assure compliance with all conditions which relate to their responsibilities. Such actions shall be consistent with the policies promulgated by the Department of Labor. If the designated community action agency is the local governing authority, the community action agency's advisory board shall have no powers as outlined in this Section other than advisory to the community action agency.

### F. Conflict of Interest

1. No board members shall engage in any selection, award, or administration of a subgrant or contract supported in total or part with CSBG funds if a conflict of interest, real or apparent, exists. Such a conflict would exist when the individual, any member of the individual's immediate family, the individual's partner or the organization that employs or is about to employ the individual has a financial interest in the award, subgrant or contract.

2. For the purpose of this Part immediate family will be defined as children, brother, sister, parent, spouse, and the parent of a spouse.

**G. Reimbursements to Board Members**

1. Board members may be reimbursed for travel required to carry out their responsibility to assure compliance with the CSBG subgrant. Travel shall be in accordance with the approved travel policy of the subgrantee and must be documented and approved by the president of the board. Travel reimbursement from CSBG funds shall be in accordance with the approved travel policy of the state.

2. Board members shall not be paid any salary or expenses other than the above referenced travel from Community Services Block Grant funds.

H. Meal Reimbursement for Board Members and Necessary Staff Attending Board Meetings. The cost of meals which are in conjunction with scheduled board business meetings held at normal meal times is allowable for board members and necessary CSBG staff in attendance. Reimbursement for such meals shall not exceed the amount allowed for those meals by the state's travel policy.

AUTHORITY NOTE: Promulgated in accordance with R.S. 23:66 et seq.

HISTORICAL NOTE: Promulgated by the Department of Employment and Training, Office of Labor, LR 16:206 (March 1990), amended LR 17:357 (April 1991), amended by the Department of Labor, Office of Labor, LR 21:1340 (December 1995).

**Chapter 9. Fiscal Policy**

**§903. Fiscal System for Subgrantees**

A. Each subgrantee shall maintain an accounting system which separately identifies the expenditure of Community Services Block Grant funds and complies with generally accepted accounting standards applicable to the subgrantee. The subgrantee's fiscal system may be reviewed by the Department of Labor prior to the award of a subgrant.

AUTHORITY NOTE: Promulgated in accordance with R.S. 23:66 et seq.

HISTORICAL NOTE: Promulgated by the Department of Employment and Training, Office of Labor, LR 16:206 (March 1990), amended LR 17:357 (April 1991), amended by the Department of Labor, Office of Labor, LR 21:1341 (December 1995).

**§905. Separate Bank Account**

A. Each subgrantee who is a private not for profit agency or a public agency that maintains an independent accounting system shall maintain a separate bank account for Community Services Block Grant funds. This account must be reconciled at the at the end of each program year and be in balance with the final closeout report. It must also be closed at the end of the program year. Variances from this requirement shall have prior written approval from the Department of Labor.

B. Public agencies or departments of a political subdivision whose receipt, recording and disbursement of all

funds is by the financial department of the political subdivision may maintain CSBG funds in the same manner as all other federal funds. Receipts and disbursements of CSBG funds are to be readily identifiable and kept in a separate journal or coded. Codes are also to be changed annually so as to identify funds of each fiscal year.

AUTHORITY NOTE: Promulgated in accordance with R.S. 23:66 et seq.

HISTORICAL NOTE: Promulgated by the Department of Employment and Training, Office of Labor, LR 16:207 (March 1990), amended LR 17:357 (April 1991), amended by the Department of Labor, Office of Labor, LR 21:1341 (December 1995).

**§907. Payment of Funds**

A. Funds will be paid to the subgrantee on a cost reimbursement basis, with a maximum of a three day cash supply limit on the amount of funds advanced.

B. The subgrantee shall prepare and submit a request for funds (LDOL 850), in duplicate, 10 days prior to the need for funds, so that the request can be processed, and funds forwarded timely. The request for funds must be approved and signed by the signator of the subgrant or a previously approved designate.

AUTHORITY NOTE: Promulgated in accordance with R.S. 23:61 et seq.

HISTORICAL NOTE: Promulgated by the Department of Employment and Training, Office of Labor, LR 16:207 (March 1990), amended LR 17:357 (April 1991).

**§909. Expenditure Reports**

A. Each subgrantee shall submit an expenditure report in duplicate to the Department of Labor. The report shall be submitted in the format, by the due date and for the period established by the Department of Labor.

B. The expenditure report shall reflect the expenditures for the month, including accruals, the cumulative expenditures, and the balance remaining on the subgrant for each cost category.

C. The expenditure report must be signed by the signator of the subgrant or a previously approved designee.

D. Failure to submit correct expenditure reports on time may result in a suspension of funds until reports are correct and current.

AUTHORITY NOTE: Promulgated in accordance with R.S. 23:66 et seq.

HISTORICAL NOTE: Promulgated by the Department of Employment and Training, Office of Labor, LR 16:207 (March 1990), amended LR 17:357 (April 1991), amended by the Department of Labor, Office of Labor, LR 21:1341 (December 1995).

**§911. Closeout of Subgrant**

A. Each subgrant must be closed after the end of the subgrant period or upon termination of a subgrant agreement. A written closeout procedure, including the due date for the closeout reports, will be issued by the Department of Labor. A subgrant will not be considered

closed until all expenses encumbered prior to the end of the program year have been paid.

B. All expenses encumbered prior to the end of the fiscal year must be paid prior to the closeout of the subgrant.

C. The bank account shall be closed prior to the submission of the closeout package, and the final statement reconciled. Any excess funds in the bank shall be returned to the Department of Labor with the closeout package.

D. Failure to submit the closeout package on time will result in a suspension of funds for the current fiscal year until the complete package is received.

AUTHORITY NOTE: Promulgated in accordance with R.S. 23:66 et seq.

HISTORICAL NOTE: Promulgated by the Department of Employment and Training, Office of Labor, LR 16:207 (March 1990), amended LR 17:357 (April 1991), amended by the Department of Labor, Office of Labor, LR 21:1341 (December 1995).

**§913. Carryover Funds**

A. No subgrant will be allowed to carry any funds forward from one fiscal year to the next.

B. Any excess funds at the end of the fiscal year will be returned to the Department of Employment and Training, with the closeout report or sooner.

AUTHORITY NOTE: Promulgated in accordance with R.S. 23:61 et seq.

HISTORICAL NOTE: Promulgated by the Department of Employment and Training, Office of Labor, LR 16:207 (March 1990), amended LR 17:357 (April 1991).

**§915. Audits**

A. Performance of Audits

1. Each subgrant using CSBG funds must be audited annually by an independent auditing firm at the end of the subgrantee's fiscal year, except that biannual audits will be allowed with the approval of the Department of Labor. Audit reports are due no later than eight months after the end of the subgrantee's fiscal year.

2. Audits of subgrants shall be included in a single audit of all the subgrantee's activities. The audit must be in accordance with the Single Audit Act of 1984, OMB Circular A-128, R.S. 24:514 and R.S. 24:517, or OMB Circular A-133, whichever is applicable to that subgrantee.

3. Selection of the auditing firm must be performed in accordance with the state procurement regulations applying to professional service contracts or as otherwise noted in these regulations in order for CSBG funding to be utilized to pay for any portion of the audit. In the event the subgrantee's procurement regulations are more restrictive, however, those regulations must be followed.

B. Audit Resolution

1. A copy of the complete audit will be forwarded to the CSBG section promptly upon completion.

2. Within 60 days of receipt of the audit report, the CSBG Unit will review the audit report and request information from the subgrantee to resolve any questioned or disallowed costs.

3. Within 30 days after receiving the request for information, the subgrantee must submit to the CSBG Unit documentation to rebut or substantiate the questioned or disallowed costs.

4. The CSBG section will review the documentation, and make recommendations to the Secretary of Labor or designee to allow or disallow the cost.

5. The Secretary of Labor or designee will make the final decision to allow or disallow the cost, and will notify the agency of the disposition.

6. Any disallowed costs must be remitted to the Department of Labor immediately upon demand. These costs may not be paid from any federal funds.

AUTHORITY NOTE: Promulgated in accordance with R.S. 23:66 et seq.

HISTORICAL NOTE: Promulgated by the Department of Employment and Training, Office of Labor, LR 16:207 (March 1990), amended LR 17:357 (April 1991), amended by the Department of Labor, Office of Labor, LR 21:1341 (December 1995).

**Chapter 11. Costs**

**§1101. Allowable Costs**

A. Only those reasonable costs which are in support of the activities in the approved CSBG subgrant and are included in the subgrant are allowable. A cost is reasonable if in its nature or amount does not exceed that which would be incurred by a prudent person under the circumstances prevailing at the time the decision was made to incur the costs. In determining the reasonableness of costs consideration should be given to the following:

1. whether there were significant deviations from the established practice of the organization which may have unjustly caused the costs to be incurred; and

2. whether the costs incurred required prior approval from the grantor agency or were specifically prohibited by any rules or regulations that were applicable to the subgrant.

B. Where prior written approval is required, inclusion in approved subgrant is for convenience and in no way implies or gives such approval.

AUTHORITY NOTE: Promulgated in accordance with R.S. 23:66 et seq.

HISTORICAL NOTE: Promulgated by the Department of Employment and Training, Office of Labor, LR 16:208 (March 1990), amended LR 17:357 (April 1991), amended by the Department of Labor, Office of Labor, LR 21:1342 (December 1995).

**§1103. Nonallowable Costs**

A. CSBG funds shall not be used for the following costs:

1. any activity which consists of lobbying and/or political activities;
2. any activity to provide voters and prospective voters with transportation to the polls in connection with an election or any voter registration activity;
3. any fines and penalties resulting from violations of any federal, state or local law;
4. any discounts allowed for timely payment of invoices;
5. any bank charges resulting from overdrawn accounts;
6. any interest, penalty or additional costs for any reason;
7. any deficits in any other grants received by the agency;
8. any entertainment costs;
9. any costs prohibited by any federal or state laws and/or regulations;
10. the costs of employee benefits not available to other similarly employed employees of the subgrantee.

AUTHORITY NOTE: Promulgated in accordance with R.S. 23:66 et seq.

HISTORICAL NOTE: Promulgated by the Department of Employment and Training, Office of Labor, LR 16:208 (March 1990), amended LR 17:357 (April 1991), amended by the Department of Labor, Office of Labor, LR 21:1342 (December 1995).

#### **§1105. Costs Requiring Prior Approval**

A. CSBG funds may be used for the following activities only if prior written approval has been received from the Department of Labor:

1. subcontracts and third party agreements for professional, consulting, and personal services including legal, and accounting services, etc;
2. any purchase of an item which has a unit purchase price of \$1,000 or more before taxes;
3. any indirect costs. Indirect costs rates and amounts must have the prior written approval of the federal cognizant agency of the subgrantee and the CSBG Unit of the Department of Labor;
4. any costs incurred by or reimbursement to persons not in positions listed in the approved subgrant except as otherwise noted in these rules;
5. the cost of employee benefits not available to all employees.

AUTHORITY NOTE: Promulgated in accordance with R.S. 23:66 et seq.

HISTORICAL NOTE: Promulgated by the Department of Employment and Training, Office of Labor, LR 16:208 (March 1990), amended LR 17:357 (April 1991), amended by the Department of Labor, Office of Labor, LR 21:1342 (December 1995).

## **Chapter 13. Subcontractors and/or Third Party Agreements**

### **§1301. Content of and Monitoring Subcontractors and/or Third Party Agreements**

A. The Department of Labor reserves the right to review and monitor the activities covered by any contract or third party agreement entered into by subgrantees.

B. Contract Content. All subcontracts and agreements entered into by subgrantees utilizing CSBG funding shall contain at a minimum the following information:

1. name, address and federal employer identification number of the contractor or third party;
2. a description of services to be offered;
3. the maximum fee to be charged;
4. the contractor agrees to pay all taxes associated with the contract from funds received;
5. the contractor agrees to make all records available to the legislative auditor of the state of Louisiana;
6. the starting and ending date of the contract;
7. the signature of both parties.

AUTHORITY NOTE: Promulgated in accordance with R.S. 23:66 et seq.

HISTORICAL NOTE: Promulgated by the Department of Employment and Training, Office of Labor, LR 16:208 (March 1990), amended LR 17:357 (April 1991), amended by the Department of Labor, Office of Labor, LR 21:1342 (December 1995).

## **Chapter 15. Procurement Policies**

### **§1501. Public and Private Agencies**

A. All procurement of goods and services, including leases, with Community Services Block Grant funds in whole or part shall be done in accordance with the state of Louisiana Procurement Regulations unless other requirements are specified in these rules or the subgrantees' or federal procurement requirements are more restrictive. The procurement requirements that are the most restrictive must be followed, except that subgrantees that are part of local government shall be allowed to utilize their approved procurement regulations for audits when their audit is part of the local government audit and are exempt from the state procurement requirements for leasing of space when they are located in a facility owned by the parish government they are a part of. Further, the Department of Labor may issue reasonable modifications to the state rules when it determines that such modifications are in the best interest of the state and the CSBG Program. Specific procurement regulations shall be issued from time to time and shall be substantially in compliance with R.S. 39, Chapter 17, The Louisiana Procurement Code.

AUTHORITY NOTE: Promulgated in accordance with R.S. 23:66 et seq.



**HISTORICAL NOTE:** Promulgated by the Department of Employment and Training, Office of Labor, LR 16:208 (March 1990), amended LR 17:357 (April 1991), amended by the Department of Labor, Office of Labor, LR 21:1342 (December 1995).

#### **§1505. State Contract Bid List**

A. Any community action agency receiving a subgrant under these rules shall be deemed a quasi public agency and will be allowed to utilize the state contract bid list for the purpose of the purchase of supplies and equipment.

**AUTHORITY NOTE:** Promulgated in accordance with R.S. 23:66 et seq.

**HISTORICAL NOTE:** Promulgated by the Department of Employment and Training, Office of Labor, LR 16:209 (March 1990), amended LR 17:357 (April 1991), amended by the Department of Labor, Office of Labor, LR 21:1343 (December 1995).

#### **§1509. Equipment Purchased with CSBG Funds**

A. Each subgrantee will maintain an inventory identifying equipment purchased with CSBG funds at a unit cost of \$250 or more including a description of the equipment identifying it as CSBG equipment, its condition, acquisition cost, serial number and a property number assigned the equipment. The property number will be affixed to the equipment in a conspicuous place. Subgrantees may utilize their existing inventory procedures, provided they meet these requirements and separately identify equipment purchased with CSBG funds. An inventory listing equipment purchased with CSBG funds will be submitted to the Department of Labor, CSBG Unit, at the end of each fiscal year with the subgrantee's closeout package. The CSBG Unit will also monitor the subgrantees to assure an inventory of equipment purchased with CSBG funds is being maintained.

B. Before equipment purchased with CSBG funds at a unit price of \$250 or more may be disposed of, written approval must be obtained from the Department of Labor, CSBG Unit. Any income resulting from the disposal of this equipment will be considered program income. The subgrantee will immediately notify the Department of Labor, CSBG Unit, of any program income obtained and it will be utilized only in support of approved CSBG activities.

C. Ownership of equipment purchased with CSBG funds rests with the CSBG subgrantee until its CSBG funding is terminated or as otherwise noted in its subgrant agreement. CSBG equipment purchases with a unit price of \$250 shall be returned to the Department of Labor, CSBG Unit, within 30 days from termination of CSBG funding and utilized for approved CSBG activities.

**AUTHORITY NOTE:** Promulgated in accordance with R.S. 23:66 et seq.

**HISTORICAL NOTE:** Promulgated by the Department of Employment and Training, Office of Labor, LR 16:209 (March 1990), amended LR 17:357 (April 1991), amended by the Department of Labor, Office of Labor, LR 21:1343 (December 1995).

#### **§1513. Loaned Equipment**

A. Whenever possible, the Department of Labor will provide needed equipment from its surplus property to be used by the agency.

**AUTHORITY NOTE:** Promulgated in accordance with R.S. 23:61 et seq.

**HISTORICAL NOTE:** Promulgated by the Department of Employment and Training, Office of Labor, LR 16:209 (March 1990), amended LR 17:357 (April 1991).

#### **§1515. Sole Source Procurement**

A. R.S. 39, the State Procurement Code will be followed to determine when sole source procurement is allowable.

**AUTHORITY NOTE:** Promulgated in accordance with R.S. 23:66 et seq.

**HISTORICAL NOTE:** Promulgated by the Department of Employment and Training, Office of Labor, LR 16:209 (March 1990), amended LR 17:357 (April 1991), amended by the Department of Labor, Office of Labor, LR 21:1343 (December 1995).

#### **§1517. Leases of Space**

A. Space may be leased when the cost is reasonable.

B. R.S. 39, the State Procurement Code will be followed, except where the subgrantee is a part of local government and is required by the local government to be located in a facility owned by local government (see §1501 of these rules).

C. Each lease must be submitted to the Department of Labor for review and approval prior to the beginning of the lease.

D. Each lease must contain a 30-day cancellation clause. The Department of Labor may not be held responsible for payments on any existing lease and/or contract which extends beyond the subgrant period. An availability of funds clause must be included.

**AUTHORITY NOTE:** Promulgated in accordance with R.S. 23:66 et seq.

**HISTORICAL NOTE:** Promulgated by the Department of Employment and Training, Office of Labor, LR 16:209 (March 1990), amended LR 17:357 (April 1991), amended by the Department of Labor, Office of Labor, LR 21:1343 (December 1995).

#### **§1521. Equipment Lease**

A. Subgrantees shall follow the Louisiana Procurement Code for the lease of any equipment in part or totally by CSBG unless their own lease requirements or federal lease requirements are more restrictive.

**AUTHORITY NOTE:** Promulgated in accordance with R.S. 23:66 et seq.

**HISTORICAL NOTE:** Promulgated by the Department of Employment and Training, Office of Labor, LR 16:210 (March 1990), amended LR 17:357 (April 1991), amended by the Department of Labor, Office of Labor, LR 21:1344 (December 1995).

## Chapter 17. Personnel

### §1701. Establishment of Personnel Policy

A. Each subgrantee will be required to have a written personnel policy, which has board approval. The personnel policy must be reasonable and available for review by the Department of Labor.

B. Policy Compliance. Each subgrantee will be required to comply with the provisions of its personnel policy.

AUTHORITY NOTE: Promulgated in accordance with R.S. 23:66 et seq.

HISTORICAL NOTE: Promulgated by the Department of Employment and Training, Office of Labor, LR 17:357 (April 1991), amended by the Department of Labor, Office of Labor, LR 21:1344 (December 1995).

## Chapter 19. Travel Policy

### §1901. Establishment of Policy

A. Each subgrantee will be required to have a written travel policy, which has been approved by its board. The travel policy will be reasonable and available for review by the Department of Labor.

AUTHORITY NOTE: Promulgated in accordance with R.S. 23:66 et seq.

HISTORICAL NOTE: Promulgated by the Department of Employment and Training, Office of Labor, LR 16:210 (March 1990), amended LR 17:357 (April 1991), amended by the Department of Labor, Office of Labor, LR 21:1344 (December 1995).

## Chapter 21. Reporting

### §2101. Activity Reports

A. Each subgrantee will be required to submit an activity report on the progress made in achieving planned activity goals. The activity reports will be submitted in the format and by the due date established by the Department of Labor.

B. Penalty for Failure to Report. Failure to submit reports by established deadlines may result in a delay or suspension of funds for the subgrantee.

AUTHORITY NOTE: Promulgated in accordance with R.S. 23:66 et seq.

HISTORICAL NOTE: Promulgated by the Department of Employment and Training, Office of Labor, LR 16:210 (March 1990), amended LR 17:357 (April 1991), amended by the Department of Labor, Office of Labor, LR 21:1344 (December 1995).

## Chapter 23. Availability and Retention of Records

### §2301. Record Availability

A. Right to Access Records. The Department of Labor, or its agent, shall have the right to review and/or copy all the records of the subgrantee pertaining to the operation of their CSBG subgrant. All such records shall be made available upon request.

B. Period of Retention. All records pertaining to the operation of the subgrant shall be retained for a period of three years after the end of the subgrant or the final resolution of any audit, whichever occurs later.

AUTHORITY NOTE: Promulgated in accordance with R.S. 23:66 et seq.

HISTORICAL NOTE: Promulgated by the Department of Employment and Training, Office of Labor, LR 16:210 (March 1990), amended LR 17:357 (April 1991), amended by the Department of Labor, Office of Labor, LR 21:1344 (December 1995).

## Chapter 25. Civil Rights Policy

### §2501. Affirmative Action Plan

A. To be eligible for funding each CSBG subgrantee shall have an affirmative action plan approved by the Secretary of the Department of Labor or designee which shall include at least the following:

1. a written equal opportunity policy statement;
2. a listing by name, race, and sex of the designated equal opportunity committee members on the subgrantee's tripartite board;
3. an equal opportunity officer;
4. a written discrimination complaint procedure;
5. a data-collection, record keeping and reporting system to provide the information required by the Department of Employment and Training; and
6. a comprehensive self-analysis, which shall include a comparison of provision of benefits on the basis of race, sex and national origin population.

B. The subgrantee shall develop the affirmative action plan to cover both staff and participants of its subgrant which will include a comparison of the subgrantee's employees and participants by race, sex, disability, age and national origin to the corresponding characteristics of the relevant work force and eligible participants.

NOTE: The affirmative action plan will become a part of the CSBG Subgrant. The LDOL's Office of Equal Opportunity and Compliance will be available for providing technical assistance to subgrantees in drafting their affirmative action plans.

AUTHORITY NOTE: Promulgated in accordance with R.S. 23:66 et seq.

HISTORICAL NOTE: Promulgated by the Department of Employment and Training, Office of Labor, LR 16:210 (March 1990), amended LR 17:357 (April 1991), amended by the Department of Labor, Office of Labor, LR 21:1344 (December 1995).

### §2503. Implementation

A. The recipient of CSBG financial assistance is required to implement its CSBG approved affirmative action plan and to ensure compliance with this Part. At a minimum, the following requirements must be met.

1. Each subgrantee board shall formally adopt an equal employment opportunity policy and establish an equal

opportunity committee which shall reflect the composition of the board in regard to the representation of the public, private and low-income sectors.

2. The equal opportunity committee shall review the determinations of the equal opportunity officer (EEO) regarding complaints of discrimination and shall oversee the enforcement of the subgrantee's civil rights program.

3. Subgrantees shall have at least one EEO, who shall report directly to the board of directors on EEO matters. Resources must be provided to the individual assigned responsibility for the civil rights program as required by this Part; as well as the assignment of such additional personnel as are necessary to carry out the requirements of this Part. The EEO shall not be the executive director, deputy director or personnel officer or their equivalents. The compliance programs director may make a recommendation that the EEO be full-time or part-time.

4. The equal opportunity officer (EEO) shall undergo training as prescribed by the Department of Labor. All expenses incurred by such training shall be borne by the subgrantee.

5. The EEO shall be granted the authority to carry out the following activities:

a. receive and attempt to resolve complaints of discrimination;

b. provide aggrieved persons with information and advise on equal opportunity procedures including local, state and federal redress procedures, and notification of the filing deadlines for equal employment opportunity commission complaints, where applicable;

c. take other steps which may assist in the resolution of a problem, prior to the filing of a formal complaint;

d. assist, if requested by a complainant, in preparing a formal complaint to the Department of Labor of alleged discrimination based on race, color, creed, sex, sexual orientation, national origin, age, disability, political affiliation or beliefs;

e. provide staff leadership in developing, implementing, and evaluating the subgrantee's affirmative action plan (AAP); and

f. provide EEO training and compliance monitoring on an ongoing basis.

6. Subgrantees shall display, in conspicuous places, posters which summarize the rights of the employees, program participants and beneficiaries under the Title VI, of the Civil Rights Act. Such posters shall describe the functions of the EEO and the procedures for filing complaints of discrimination, including the right to complain directly to the Department of Labor as part of their complaint procedure.

7. In addition to the posters, each subgrantee shall make available information regarding the provisions of this

Part and its applicability to the program under which the subgrantee receives federal financial assistance and make such information available in such manner as the compliance programs director or designee finds necessary to apprise such persons of the protections against discrimination. In accordance with the Americans with Disabilities Act, this information must be available for individuals with both hearing and vision impairments.

8. Within 30 days of the termination of its subgrant, a report describing the activities and actions taken under its subgrant, including but not limited to changes in employee makeup, agency rules, effects of layoffs, and demotions and promotions, must be submitted to the grantor.

AUTHORITY NOTE: Promulgated in accordance with R.S. 23:66 et seq.

HISTORICAL NOTE: Promulgated by the Department of Employment and Training, Office of Labor, LR 16:211 (March 1990), amended LR 17:357 (April 1991), amended by the Department of Labor, Office of Labor, LR 21:1344 (December 1995).

## Chapter 27. Clarification of Rules

### §2701. Method for Clarification

A. Clarification to the rules contained in this CSBG policy manual and special clauses shall be made as required in program issuances. These program issuances will become effective upon written notification to the subgrantees.

AUTHORITY NOTE: Promulgated in accordance with R.S. 23:61 et seq.

HISTORICAL NOTE: Promulgated by the Department of Employment and Training, Office of Labor, LR 16:211 (March 1990), amended LR 17:357 (April 1991).

## Chapter 29. Appeal of Termination or Reduction of Funding

### §2901. Termination and Reduction of Funding; Appeal

A. Termination or Reduction of Funding Notice. The Department of Labor will notify the agency in writing of the intention to terminate funding or reduce funding below its proportional share, and shall state the reasons for the termination or reduction in funding.

B. An agency has the right to request a hearing prior to termination or reduction of funding. The request for a hearing must be filed within five days of the notice of intention to terminate or reduce funding. The hearing will be held in accordance with the procedures outlined in §2903.

AUTHORITY NOTE: Promulgated in accordance with R.S. 23:66 et seq.

HISTORICAL NOTE: Promulgated by the Department of Employment and Training, Office of Labor, LR 16:211 (March 1990), amended LR 17:357 (April 1991), amended by the Department of Labor, Office of Labor, LR 21:1345 (December 1995).

### §2903. Selection of Hearing Officer and Responsibilities

A. Specific person(s) should be identified by the Department of Labor to function in a quasi-judicial capacity

in relation to the hearing process. Each party will be notified as to the hearing officer(s) selected to conduct their appeal or hearing at least 10 days prior to the hearing. Standards to be applied in selection of these persons are as follows.

1. They should have independence in obtaining facts and making decisions.

2. The hearing officer(s) must be in a position to render impartial decisions that are fair.

B. If either party to the complaint is aware of facts or circumstances which put the designated hearing officer's independence and impartiality in question, the appointing body should be notified within five days of receiving notice. An alternate(s) will be appointed if deemed appropriate by the Department of Labor. In all cases, documentation regarding the allegation and how it was handled should be included in the file.

C. Responsibilities within the scope of the designated hearing officer(s) are:

1. directs preparation of and reviews a complete file on the case prior to the hearing;

2. directs parties to appear at hearing;

3. holds hearing;

4. receives evidence;

5. disposes of procedural requests;

6. questions witnesses and parties, as required;

7. considers and evaluates facts, evidence and arguments to determine credibility;

8. renders decision and issues it in writing to all parties involved; and

9. provides the complete record including:

a. all pleadings, motions and intermediate rulings;

b. detailed minutes of the oral testimony plus all other evidence received or considered;

c. a statement of matters officially noted;

d. all staff memoranda or data submitted to the decision maker in connection with their consideration of the case;

e. findings of fact based on the evidence submitted at the hearing;

f. notification of further appeal procedures, if applicable; and

g. final decision of the hearing officer.

D. The hearing may be conducted informally. Unnecessary technicalities (i.e., legal requirements that would be appropriate in court proceedings) should be avoided. It will provide the flexibility to enable adjustment to the circumstances presented. The following guidance is provided in respect to the hearings.

1. Full regard should be given to the requirements of due process to ensure a fair and impartial hearing.

2. All testimony at any hearing before the hearing officer(s) designated at the state level shall be mechanically recorded.

3. The hearing officer should begin the hearing by summarizing the record and the issues, affording both parties an opportunity to review such record, and should explain the manner in which the hearing will be conducted, making sure that everyone involved understands the proceedings. Such explanation should be adapted to the needs of the specific situation. The hearing officer shall take testimony under oath or affirmation to give some assurances of veracity to the hearing.

4. The burden of proof should be reasonable and flexible, dependent upon the circumstances of the case involved. The hearing officer(s) determines the order of proof. Generally, the agency making the complaint has the obligation of establishing its case, and should be examined first.

5. The parties involved may be represented, but are responsible for securing such representation. Otherwise, he/she is limited to his/her own abilities and those of the hearing officer(s) in obtaining testimony in the case.

6. It is important that the hearing officer(s) obtain the fullest information for the record. If the parties involved, or their representatives, do not know how to ask the right or pertinent question, in pursuing their right to due process, it shall be necessary for the hearing officer(s) to assist in having all the material and relevant facts elicited.

7. The practice in informal hearings is generally not to apply strict rules of evidence in obtaining facts. However, the quantity of evidence required to support a decision on an issue should be sufficiently credible that a court, upon reviewing the decision, would conclude that it is supported by substantial evidence.

8. The general rules in law should be applied in decision on remedies, which should be reasonable and fit the problem and/or violation.

9. The hearing officer(s) may accept any resolution of the issue agreeable to all parties at any time prior to the rendering of a decision, as long as such agreement does not violate state or federal law.

**AUTHORITY NOTE:** Promulgated in accordance with R.S. 23:66 et seq.

**HISTORICAL NOTE:** Promulgated by the Department of Labor, Office of Labor, LR 21:1345 (December 1995).

#### **§2905. Hearing Notice**

A. The procedure required to hold a hearing shall include reasonable notice by registered or certified mail, or by hand with signature indicating receipt. The notice will include:

1. a statement of the time and place of hearing;

2. the identity of the hearing officer;

3. a statement of the authority and jurisdiction under which the hearing is to be held;

4. a reference to the particular section of the Act, regulations, grant or other agreements under the Act involved;

5. notice to the parties of the specific charges involved;

6. the right of both parties to be represented by legal counsel;

7. the right of each party to bring witnesses and/or documentary evidence; and

8. the right of each party to cross examination.

AUTHORITY NOTE: Promulgated in accordance with R.S. 23:66 et seq.

HISTORICAL NOTE: Promulgated by the Department of Labor, Office of Labor, LR 21:1346 (December 1995).

**§2907. Decision; Appeal**

A. The hearing officer shall render a decision within 10 days after the hearing is held. Written notification of the decision shall be mailed to the interested parties. The decision will become final within 15 days unless an appeal is filed.

B. The agency may appeal the decision to the Secretary of the U.S. Department of Health and Human Services within 15 days after the receipt of the decision. If no appeal is filed, the decision is final.

AUTHORITY NOTE: Promulgated in accordance with R.S. 23:66 et seq.

HISTORICAL NOTE: Promulgated by the Department of Labor, Office of Labor, LR 21:1346 (December 1995).



**Title 40**  
**LABOR AND EMPLOYMENT**  
**Part XIX. Louisiana Workforce Commission**

**Chapter 1. Community and Technical  
Colleges Investment Fund**

**§101. Purpose**

A. Funds appropriated by the legislature to the Community and Technical Colleges Investment Fund are available exclusively to the Louisiana Workforce Commission for use in efforts to ensure the responsiveness of state community and technical colleges toward meeting the needs of Louisiana's businesses and industries and the needs of Louisiana's citizens for the development of a quality workforce.

AUTHORITY NOTE: Promulgated in accordance with R.S. 23:2055 and R.S. 23:2071.

HISTORICAL NOTE: Promulgated by the Office of the Governor, Office of Lifelong Learning, Workforce Commission, LR 24:2254 (December 1998).

**§103. Definitions**

*Applicant*—the community or technical college requesting funds under this program from the workforce commission, in order to provide training in partnership with one or more employers.

*Award*—funding approved under this program for approved activities.

*Awardee*—an applicant receiving a training award under this program.

*Employers*—the employers participating in a training partnership.

*Training Provider*—the community or technical college providing the training.

AUTHORITY NOTE: Promulgated in accordance with R.S. 23:2055 and R.S. 23:2071.

HISTORICAL NOTE: Promulgated by the Office of the Governor, Office of Lifelong Learning, Workforce Commission, LR 24:2254 (December 1998).

**§105. Eligibility**

A. An applicant shall be eligible for training funds if it is a public community college, technical college or a consortium of two or more community and/or technical colleges that develops a partnership with one or more employers for the purpose of designing or redesigning training programs to meet the needs of business and industry.

B. All eligible applicants must demonstrate that they are collaborating in developing and operating a continuing job preparatory program designed to produce skilled workers in a particular trade or technical occupation(s).

AUTHORITY NOTE: Promulgated in accordance with R.S. 23:2055 and R.S. 23:2071.

HISTORICAL NOTE: Promulgated by the Office of the Governor, Office of Lifelong Learning, Workforce Commission, LR 24:2254 (December 1998).

**§107. Criteria**

A. Applicants must incorporate the goals of the workforce commission into their training program design and operation. The workforce commission's adopted goals focus on a workforce system that will become:

1. customer focused;
2. performance based;
3. market driven;
4. streamlined;
5. locally operated;
6. focused on the work ethic.

B. Community and technical college applicants must certify the existence of a partnership with one or more employers.

C. The proposed training program must incorporate industry-based skills standards. If such standards are not applicable to the type of training, the applicant must provide an explanation and must indicate an alternate standardized measure of skill acquisition.

D. The applicant and the employer partner must certify the need for job preparatory training by projecting job demand. The growth and demand job forecast, upon which the need is projected, must be substantiated.

E. The community and/or technical college applicant shall commit resources from its current budget toward the total costs for the proposed program or project.

F. Applicants must complete a budget for approval by the commission. Administrative costs shall not exceed 10 percent of costs.

G. The workforce commission shall work in consultation with employers, training providers and organized labor in determining the allocation of monies appropriated under this fund.

H. The workforce commission will consider the following factors in selecting awardees:

1. long-term program need (job demand);
2. level of employer interest and participation in program design and operation;

## LABOR AND EMPLOYMENT

3. level of employer leveraged resources and financial assistance for the program;

4. number of employers served, particularly small employers;

5. amount of college's existing resources being converted to the proposed program;

6. strength and long-term viability of the partnership and program;

7. average hourly wage rates projected for employed trainees upon completion of training;

8. program accessibility in terms of scheduling;

9. opportunities for career advancement;

10. utilization of skill standards and industry-based certification or alternate standard measure of skill acquisition;

11. capacity for bringing qualified disadvantaged citizens, welfare-to-work participants, inmates or parolees into the workforce.

I. Program performance shall be based upon:

1. the performance standards adopted by the workforce commission, which measure the effectiveness of a training program in terms of:

a. placement (employment of participants upon completion or exit from program);

b. training-related placement;

c. adequacy of training;

d. customer satisfaction (The customers are both the employers who need trained workers and the citizens who seek training.); and

2. semi-annual progress reports submitted to the workforce commission for review and approval.

J. Awardees shall participate in the development of the Scorecard component of the Occupational Information System, which consists of a website display of performance data derived by matching participant exit data with agency databases, such as, with the Unemployment Insurance database from the Department of Labor.

K. Funds awarded shall be used to design or redesign a training program/project, and awardees shall plan for sustainability of a program/project following the cessation of award.

**AUTHORITY NOTE:** Promulgated in accordance with R.S. 23:2055 and R.S. 23:2071.

**HISTORICAL NOTE:** Promulgated by the Office of the Governor, Office of Lifelong Learning, Workforce Commission, LR 24:2254 (December 1998).

### §109. Application Procedure

A. The workforce commission will provide a standard form for use by applicants. The application form will

contain, but not be limited to, detailed descriptions of the following:

1. a description of the process that will be used by the community/technical college(s) and the employer partner(s) for planning and collaboration. This process shall include the structure through which the partnership will assess needs, make decisions and take corrective actions, as necessary;

2. certification of the growth and demand job need that warrants the preparatory training. The forecasted projection must be based upon analysis of current and future job trends, and the basis for the projection must be provided;

3. a description of the proposed training program to include:

a. curriculum;

b. pre-employment and any post-employment training;

c. recruitment of students;

d. scheduling;

e. staffing;

f. student to teacher ratio;

g. provision for any accelerated learning in the workplace; or

h. other important program components;

4. a written commitment from each employer partner to participate in the development and design of a job preparatory training program in a specific occupational field and to provide assistance. The commitment from participating employers shall include a description of the intended leveraged resources, including any financial contribution;

5. a written commitment from each college partner to collaborate with the employer(s) on the design and implementation of the program, along with a written description of the data collection methodology and the resources committed to the training by the college;

6. a proposed budget with administrative costs not to exceed 10 percent of costs;

7. any additional information the workforce commission may require.

**AUTHORITY NOTE:** Promulgated in accordance with R.S. 23:2055 and R.S. 23:2071.

**HISTORICAL NOTE:** Promulgated by the Office of the Governor, Office of Lifelong Learning, Workforce Commission, LR 24:2255 (December 1998).

### §111. Submission and Review Procedure

A. Applicants must submit their completed application to the workforce commission. Submitted applications will be reviewed and evaluated by a committee of the workforce commission and by staff. The applicant and the employer partner(s) may be required to present orally the concepts of the proposal to the reviewers.



B. Following review of applications, the committee will forward prioritized recommendations to the workforce commission. The applications will then be reviewed and approved by the workforce commission.

C. A copy of the award letter will be sent to the respective board(s) for the community and technical colleges. No funds spent on the project prior to the commission's approval of award will be considered eligible project costs.

D. The commission will issue an award letter to the applicant within five working days of the application approval by the workforce commission.

AUTHORITY NOTE: Promulgated in accordance R.S. 23:2055 and R.S. 23:2071.

HISTORICAL NOTE: Promulgated by the Office of the Governor, Office of Lifelong Learning, Workforce Commission, LR 24:2255 (December 1998).

**§113. General Award Provision**

**A. Award Contract**

1. A contract will be executed between the workforce commission and the awardee. The contract will specify the goals and objectives expected and the compliance requirements.

2. The workforce commission staff will monitor the progress of the training.

3. The workforce commission will reimburse the training provider from invoices submitted by the workforce commission and will disburse funds from invoices or certification of work completed.

4. Funds may be used for training programs extending up to two years in duration.

**B. Use of Funds**

1. The Community and Technical Colleges Investment Fund offers financial assistance in the form of an award for reimbursement of eligible training costs specified in the award agreement.

2. Eligible training costs may include, inter alia, the following:

a. instruction costs: wages for technical and community college instructors, contracts for vendor trainer, training seminars;

b. travel costs: travel expenses reimbursable under this agreement will comply with state Travel Regulation, PPM 49. Travel costs are limited to 15 percent of the total training award;

c. materials and supplies costs: training texts and manuals, audio/visual materials, skills assessment, training materials, computer based training software; and

d. capital outlay: equipment and facility modification.

**C. Conditions for Disbursement of Funds**

1. Funds will be available on a reimbursement basis following submission of approved invoices to the workforce commission. No funds spent on the project prior to the commission's approval of the award will be considered eligible project costs.

2. All disbursements of funds shall be made to the training provider cited as the awardee.

**D. Compliance Requirements**

1. Training providers shall be required to complete semiannual reports describing progress toward the goals and objectives specified in their contract with the workforce commission.

2. In the event the awardee fails to meet its goals and objectives specified in its contract with the workforce commission, the commission shall retain the right to withhold award funds, modify the terms and conditions of the award, and to reclaim disbursed funds from the awardee in an amount commensurate with the scope of the unmet goals and objectives.

3. In the event the awardee or monitoring entity knowingly files a false statement in its application or in a progress report, the awardee or monitoring entity shall be guilty of the offense of filing false public records and shall be subject to the penalty provided for in R.S. 14:133.

4. The workforce commission shall retain the right to require and/or conduct financial and performance audits of a project, including all relevant records and documents of the awardee and the monitoring entity.

AUTHORITY NOTE: Promulgated in accordance with R.S. 23:2055 and R.S. 23:2071.

HISTORICAL NOTE: Promulgated by the Office of the Governor, Office of Lifelong Learning, Workforce Commission, LR 24:2255 (December 1998).

**Chapter 3. General Rules**

**§301. Interested Party Petitions**

A. Any interested person may petition the secretary of the Workforce Commission requesting the adoption, amendment, or repeal of a rule.

B. A petition for adoption, amendment, or repeal of a rule shall be styled as such and shall include:

1. the petitioner's name, mailing address, email address, and original signature;

2. the specific text or a description of the proposed language desired for amendment or adoption of a rule, or the specific rule and language identified for repeal; and

3. justification for the proposed action with a description of the intended effect.

C. The secretary of the Workforce Commission may deny any petition for adoption, amendment, or repeal of a rule that does not conform to the requirements of this Section.

## LABOR AND EMPLOYMENT

D. After submission of a petition pursuant to this section, within 90 days of receipt, the secretary of the Workforce Commission either shall deny the petition in writing stating the reasons for denial, or shall initiate rulemaking proceedings in accordance with the Louisiana Administrative Procedure Act. The secretary retains sole discretion to grant or deny a petition.

E. Nothing herein shall be construed to require that the secretary of the Workforce Commission, in granting a petition for adoption, amendment, or repeal of a rule, adopt or employ the specific form or language requested by the

petitioner, provided that the Workforce Commission's actions give effect to the substance and intent of the petition.

F. The rulemaking petition shall be submitted by certified mail and addressed to:

Office of the Secretary, Louisiana Workforce Commission  
Re: Rulemaking Petition  
P.O. Box 94094  
Baton Rouge, LA 70804-9094

AUTHORITY NOTE: Promulgated in accordance with RS 36:304 and 49:953 et seq.

HISTORICAL NOTE: Promulgated by Workforce Commission, Office of the Secretary, LR 46:51 (January 2020).

**Title 40**  
**LABOR AND EMPLOYMENT**  
**Part XXI. High Unemployment Areas**

**Chapter 1. Certification of High  
Unemployment Areas**

**§101. Application Fee**

A. An application fee in the amount of \$250 shall be required for each request for certification of a high unemployment area under the Employment Based Fifth Category Visa Program (EB-5).

B. All fees shall be paid in advance by check, money order, or other authorized method of payment and made payable to: Louisiana Workforce Commission. Cash cannot be accepted.

AUTHORITY NOTE: Promulgated in accordance with 8 CFR part 204.6(i) and R.S. 36:310.

HISTORICAL NOTE: Promulgated by the Workforce Commission, Office of Workforce Development, LR 42:445 (March 2016).



**Title 40**  
**LABOR AND EMPLOYMENT**  
**Part XXVII. Civil Service Commission**

Editor's Note: The following Part has been moved from Title 8 to Title 40 in accordance with the Office of the State Register's uniform system of codification.

**Chapter 1. Public Officials and  
Employees**

**§101. Election of Employee Member of the State Civil Service Commission**

**A. Qualifications—Term of Office**

1. The classified employee member of the State Civil Service Commission shall be a full-time, permanent employee in the classified state service for a period of one year prior to the date on which he qualifies as a candidate and shall serve a term of six years unless serving to fill the unexpired term of a vacancy.

2. The classified employee eligible to fill an unexpired term will take office after notification of a vacancy by the director of State Civil Service to the Secretary of State and upon certification by the Secretary of State, who shall certify in accordance with law. That employee will serve until a new regular election is conducted to elect a successor.

**B. Call for Election**

1. The Director of State Civil Service shall post on the date it is issued the call for election on bulletin board(s) at the office of the Director of State Civil Service and on the web site maintained by the Department of State Civil Service. It shall remain posted until the final day for qualification as a candidate has passed. A copy of the call shall be delivered to the Secretary of State for publication in the official state journal.

**C. Nominations**

1. Candidates for election to the office of Classified Employee Member of the State Civil Service Commission must include on the nomination petition their name as it is to appear on the ballot, their position classification (job), the department, agency, board or commission at which employed, their home address, their work email address (if applicable) and the last four digits of their Social Security number or any other personal identification number designated by the director of State Civil Service.

2. The nominating petition shall include the signature, printed name, last four digits of the Social Security number or any other personal identification number designated by the director of State Civil Service, and the department, agency, board or commission of each employee signing the petition.

3. The director of State Civil Service, or his designated representative, shall examine the nominating petition of each candidate on receipt, determine whether the person nominated is eligible or ineligible and that the petition is valid or invalid, and so notify the candidate of his decision by close of business on the first business day following receipt by mailing such notification to the candidate's home address or by emailing it to the work email address provided in the nomination petition.

4. A candidate may withdraw his name from nomination by notifying the Director of State Civil Service in writing prior to the end of the qualifying period.

**D. Conduct of Election**

1. All eligible candidates shall have their names listed on the ballot in alphabetical order of their last name, exactly as it appears on the nominating petition.

2. Election brochures shall contain ballot instructions for voting, information about each candidate whose name appears on the ballot, in alphabetical order of their last name, and the final date for voting.

3. Instructions shall contain directions about the secrecy of the balloting process with reference to state law providing for punishment for violating that secrecy.

4. Ballots and election brochures shall be emailed to every employee who is qualified to vote using the employee's official work email address as maintained by the employing agency or, for employees without a work email address or who have expressed a preference to vote via U.S. Mail, mailed to the last mailing address reported by the appointing authority to State Civil Service.

5. The director of State Civil Service shall supervise and be responsible for the election to ensure that it is conducted in accordance with the requirements of R.S. 42:1351 through 1360.

6. Voting may be conducted electronically or by U.S. mail. Electronic means shall be via telephone, via Internet or by any other acceptable electronic means.

7. The election process will include verification that each person casting a vote is qualified to vote and that no voter casts more than one vote.

8. The director of State Civil Service may contract with a vendor to conduct the election under the director's supervision.

## LABOR AND EMPLOYMENT

### E. Report of Results

1. The director of State Civil Service shall provide a written report of certified election results to the State Civil Service Commission and the Secretary of State.

2. A copy of the report shall be posted at the office of the Director of State Civil Service and on the Department of State Civil Service web site for five consecutive working

days following submission of the report to the Secretary of State.

**AUTHORITY NOTE:** Promulgated in accordance with R.S. 42:1357(B).

**HISTORICAL NOTE:** Promulgated by the Department of Civil Service, Civil Service Commission, LR 24:2077 (November 1998), amended LR 30:2444 (November 2004), LR 48:2548 (October 2022).